

Rules for the Type Approval of Fixed Clean Agent Fire-Extinguishing Systems in Machinery Spaces

Effective from 1/5/2024



GENERAL CONDITIONS

Definitions:

Administration means the Government of the State whose flag the ship is entitled to fly or under whose authority the ship is authorized to operate in the specific case.

“IACS” means the International Association of Classification Societies.

“Interested Party” means the party, other than the Society, having an interest in or responsibility for the Ship, product, plant or system subject to classification or certification (such as the owner of the Ship and his representatives, the shipbuilder, the engine builder or the supplier of parts to be tested) who requests the Services or on whose behalf the Services are requested.

“Owner” means the registered owner, the shipowner, the manager or any other party with the responsibility, legally or contractually, to keep the ship seaworthy or in service, having particular regard to the provisions relating to the maintenance of class laid down in Part A, Chapter 2 of the Rules for the Classification of Ships or in the corresponding rules indicated in the Specific Rules.

“Rules” in these General Conditions means the documents below issued by the Society:

- (i) Rules for the Classification of Ships or other special units.
- (ii) Complementary Rules containing the requirements for product, plant, system and other certification or containing the requirements for the assignment of additional class notations;
- (iii) Rules for the application of statutory rules, containing the rules to perform the duties delegated by Administrations.
- (iv) Guides to carry out particular activities connected with Services;
- (v) Any other technical document, for example, rule variations or interpretations.

“Services” means the activities described in paragraph 1 below, rendered by the Society upon request made by or on behalf of the Interested Party.

“Ship” means ships, boats, craft and other special units, for example, offshore structures, floating units and underwater craft.

“Society” or **“TASNEEF”** means TASNEEF Maritime

“Surveyor” means technical staff acting on behalf of the Society in performing the Services.

“Force Majeure” means damage to the ship; unforeseen inability of the Society to attend the ship due to government restrictions on right of access or movement of personnel; unforeseeable delays in port or inability to discharge cargo due to unusually lengthy periods of severe weather, strikes or civil strife; acts of war; or other force majeure.

1. Society Roles

1.1. The purpose of the Society is, among others, the classification and certification of ships and the certification of their parts and components. In particular, the Society:

- (i) sets forth and develops Rules.
- (ii) publishes the Register of Ships.
- (iii) Issues certificates, statements and reports based on its survey activities.

1.2. The Society also takes part in the implementation of national and international rules and standards as delegated by various Governments.

1.3. The Society carries out technical assistance activities on request and provides special services outside the scope of classification, which is regulated by these general conditions unless expressly excluded in the particular contract.





2. Rule Development, Implementation and Selection of Surveyor

2.1. The Rules developed by the Society reflect the level of its technical knowledge at the time they are published therefore, the Society, although also committed through its research and development services to continuous updating of the Rules, does not guarantee the Rules meet state-of-the-art science and technology at the time of publication or that they meet the Society's or others' subsequent technical developments.

2.2. The Interested Party is required to know the Rules based on which the Services are provided. With particular reference to Classification Services, special attention is to be given to the Rules concerning class suspension, withdrawal and reinstatement. In case of doubt or inaccuracy, the Interested Party is to promptly contact the Society for clarification. The Rules for Classification of Ships are published on the Society's website: www.tasneef.ae.

2.3. Society exercises due care and skill:

(i) In the selection of its Surveyors

(ii) In the performance of its Services, taking into account the level of its technical knowledge at the time the Services are performed.

2.4. Surveys conducted by the Society include, but are not limited to, visual inspection and non-destructive testing. Unless otherwise required, surveys are conducted through sampling techniques and do not consist of comprehensive verification or monitoring of the Ship or the items subject to certification. The surveys and checks made by the Society on board ship do not necessarily require the constant and continuous presence of the Surveyor. The Society may also commission laboratory testing, underwater inspection and other checks carried out by and under the responsibility of qualified service suppliers. Survey practices and procedures are selected by the Society based on its experience and knowledge and according to generally accepted technical standards in the sector.

3. Class Report & Interested Parties Obligation

3.1. The class assigned to a Ship, like the reports, statements, certificates or any other document or information issued by the Society, reflects the opinion of the Society concerning compliance, at the time the Service is provided, of the Ship or product subject to certification, with the applicable Rules (given the intended use and within the relevant time frame). The Society is under no obligation to make statements or provide information about elements or facts which are not part of the specific scope of the Service requested by the Interested Party or on its behalf.

3.2. No report, statement, notation on a plan, review, Certificate of Classification, document or information issued or given as part of the Services provided by the Society shall have any legal effect or implication other than a representation that, on the basis of the checks made by the Society, the Ship, structure, materials, equipment, machinery or any other item covered by such document or information meet the Rules. Any such document is issued solely for the use of the Society, its committees and clients or other duly authorized bodies and no other purpose. Therefore, the Society cannot be held liable for any act made or document issued by other parties based on the statements or information given by the Society. The validity, application, meaning and interpretation of a Certificate of Classification, or any other document or information issued by the Society in connection with its Services, is governed by the Rules of the Society, which is the sole subject entitled to make such interpretation. Any disagreement on technical matters between the Interested Party and the Surveyor in the carrying out of his functions shall be raised in writing as soon as possible with the Society, which will settle any divergence of opinion or dispute.

3.3. The classification of a Ship or the issuance of a certificate or other document connected with classification or certification and in general with the performance of Services by the Society shall have the validity conferred upon it by the Rules of the Society at the time of the assignment of class or issuance of the certificate; in no case shall it amount to a statement or warranty of seaworthiness, structural integrity, quality or fitness for a particular purpose or service of any Ship, structure, material, equipment or machinery inspected or tested by the Society.

3.4. Any document issued by the Society about its activities reflects the condition of the Ship or the subject of certification or other activity at the time of the check.

3.5. The Rules, surveys and activities performed by the Society, reports, certificates and other documents issued by the Society are in no way intended to replace the duties and responsibilities of other parties such as Governments, designers, shipbuilders, manufacturers, repairers, suppliers, contractors or sub-contractors, Owners, operators, charterers, underwriters, sellers or intended buyers of a Ship or other product or system surveyed.





These documents and activities do not relieve such parties from any fulfilment, warranty, responsibility, duty or obligation (also of a contractual nature) expressed or implied or in any case incumbent on them, nor do they confer on such parties any right, claim or cause of action against the Society. With particular regard to the duties of the ship Owner, the Services undertaken by the Society do not relieve the Owner of his duty to ensure proper maintenance of the Ship and ensure seaworthiness at all times. Likewise, the Rules, surveys performed, reports, certificates and other documents issued by the Society are intended neither to guarantee the buyers of the Ship, its components or any other surveyed or certified item, nor to relieve the seller of the duties arising out of the law or the contract, regarding the quality, commercial value or characteristics of the item which is the subject of transaction.

In no case, therefore, shall the Society assume the obligations incumbent upon the above-mentioned parties, even when it is consulted in connection with matters not covered by its Rules or other documents.

In consideration of the above, the Interested Party undertakes to relieve and hold harmless the Society from any third-party claim, as well as from any liability about the latter concerning the Services rendered.

Insofar as they are not expressly provided for in these General Conditions, the duties and responsibilities of the Owner and Interested Parties concerning the services rendered by the Society are described in the Rules applicable to the specific service rendered.

4. Service Request & Contract Management

4.1. Any request for the Society's Services shall be submitted in writing and signed by or on behalf of the Interested Party. Such a request will be considered irrevocable as soon as received by the Society and shall entail acceptance by the applicant of all relevant requirements of the Rules, including these General Conditions. Upon acceptance of the written request by the Society, a contract between the Society and the Interested Party is entered into, which is regulated by the present General Conditions.

4.2 In consideration of the Services rendered by the Society, the Interested Party and the person requesting the service shall be jointly liable for the payment of the relevant fees, even if the service is not concluded for any cause not pertaining to the Society. In the latter case, the Society shall not be held liable for non-fulfilment or partial fulfilment of the Services requested.

4.3 The contractor for the classification of a ship or for the services may be terminated and any certificates revoked at the request of one of the parties, subject to at least 30/60/90 days' notice, to be given in writing. Failure to pay, even in part, the fees due for services carried out by the society will entitle the society to immediately terminate the contract and suspend the service.

For every termination of the contract, the fees for the activities performed until the time of the termination shall be owned to the society as well as the expenses incurred in view of activities already programmed, this is without prejudice to the right to compensation due to the society as a consequence of the termination.

With particular reference to ship classification and certification, unless decided otherwise by the society, termination of the contract implies that the assignment of class to a ship is withheld or, if already assigned, that it is suspended or withdrawn, any statutory certificates issued by society will be withdrawn in those cases where provided for by agreements between the society and the flag state.

5. Service Accuracy

5.1. In providing the Services, as well as other correlated information or advice, the Society, its Surveyors, servants or agents operate with due diligence for the proper execution of the activity. However, considering the nature of the activities performed (see **Rule Development, Implementation and Selection of Surveyor 2.4**), it is not possible to guarantee absolute accuracy, correctness and completeness of any information or advice supplied. Express and implied warranties are specifically disclaimed.





6. Confidentiality & Document sharing

6.1. All plans, specifications, documents and information provided by, issued by, or made known to the Society, in connection with the performance of its Services, will be treated as confidential and will not be made available to any other party other than the Owner without authorization of the Interested Party, except as provided for or required by any applicable international, European or domestic legislation, Charter or other IACS resolutions, or order from a competent authority. Information about the status and validity of class and statutory certificates, including transfers, changes, suspensions, withdrawals of class, recommendations/conditions of class, operating conditions or restrictions issued against classed ships and other related information, as may be required, may be published on the website or released by other means, without the prior consent of the Interested Party.

Information about the status and validity of other certificates and statements may also be published on the website or released by other means, without the prior consent of the Interested Party.

6.2. Notwithstanding the general duty of confidentiality owed by the Society to its clients in clause 7.1 below, the Society's clients hereby accept that the Society may participate in the IACS Early Warning System which requires each Classification Society to provide other involved Classification Societies with relevant technical information on serious hull structural and engineering systems failures, as defined in the IACS Early Warning System (but not including any drawings relating to the ship which may be the specific property of another party), to enable such useful information to be shared and used to facilitate the proper working of the IACS Early Warning System. The Society will provide its clients with written details of such information sent to the involved Classification Societies.

6.3. In the event of transfer of class, addition of a second class or withdrawal from a double/dual-class, the Interested Party undertakes to provide or to permit the Society to provide the other Classification Society with all building plans and drawings, certificates, documents and information relevant to the classed unit, including its history file, as the other Classification Society may require for classification in compliance with the applicable legislation and relative IACS Procedure. It is the Owner's duty to ensure that, whenever required, the consent of the builder is obtained about the provision of plans and drawings to the new Society, either by way of the appropriate stipulation in the building contract or by other agreement.

In the event that the ownership of the ship, product or system subject to certification is transferred to a new subject, the latter shall have the right to access all pertinent drawings, specifications, documents or information issued by the Society or which has come to the knowledge of the Society while carrying out its Services, even if related to a period prior to transfer of ownership.

7. Health, Safety & Environment

7.1. The clients such as the designers, shipbuilders, manufacturers, repairers, suppliers, contractors or sub-contractors, or other product or system surveyed who have a registered office in ABU Dhabi; should have an approved OSHAD as per Abu Dhabi OHS Centre, or, if they do not need to have an approved OSHAD, they shall comply with TASNEEF standards and have procedures in place to manage the risks from their undertakings.

7.2. For the survey, audit and inspection activities onboard the ship, the ship's owner, the owner representative or the shipyard must follow TASNEEF rules regarding the safety aspects.

8. Validity of General Conditions

8.1. Should any part of these General Conditions be declared invalid, this will not affect the validity of the remaining provisions.





9. Force Majeure

9.1 Neither Party shall be responsible to the other party for any delay or failure to carry out their respective obligations insofar as such delay and failure derives, directly or indirectly, and at any time, from force majeure of any type whatsoever that lies outside the control of either Party.

9.2 The Party that is unable to fulfil the agreement due to Force Majeure shall inform the other party without delay and in all cases within 7 days from when such force majeure arose.

9.3 It is understood that if such force majeure continues for more than 30 days, the Party not affected by the event may terminate this agreement by registered letter. The rights matured until the day in which the force majeure occurred remain unaffected.

10. Governing Law and Jurisdiction

This Agreement shall be governed by and construed in accordance with the laws of Abu Dhabi and the applicable Federal Laws of the UAE.

Any dispute arising out of or in accordance with this Agreement shall be subject to the exclusive jurisdiction of the Abu Dhabi courts.

11. Code of Business conduct

The **CLIENT** declares to be aware of the laws in force about the responsibility of the legal persons for crimes committed in their interest or to their own advantage by persons who act on their behalf or cooperate with them, such as directors, employees or agents.

In this respect, the **CLIENT** declares to have read and fully understood the “**Ethical Code**” published by **TASNEEF** and available in the **TASNEEF** Web site.

The **CLIENT**, in the relationships with **TASNEEF**, guarantees to refrain from any behaviour that may incur risk of entry in legal proceedings for crimes or offences, whose commission may lead to the enforcement of the laws above.

The **CLIENT** also acknowledges, in case of non-fulfilment of the previous, the right of **TASNEEF** to unilaterally withdraw from the contract/agreement even if there would be a work in progress situation or too early terminate the contract/agreement. It's up to **TASNEEF** to choose between the two above mentioned alternatives, and in both cases a registered letter will be sent with a brief sum-up of the circumstances or of the legal procedures proving the failure in following the requirements of the above-mentioned legislation.

In light of the above, it is forbidden to all employees and co-operators to:

- receive any commission, percentage or benefits of any possible kind;
- Start and maintaining any business relationship with **Clients** that could cause conflict of interests with their task and function covered on behalf of **TASNEEF**.
- Receive gifts, travel tickets or any other kind of benefits different from monetary compensation, that could exceed the ordinary business politeness.

Violation of the above-mentioned principles allows **TASNEEF** to early terminate the contract and to be entitled to claim compensation for losses if any.



Chapter 1: General Requirements for Approval

1	GENERAL	1
1.1	Premise	1
1.2	Field of Application.....	1
1.2.1	General	1
1.2.2	Alternative	1
1.3	Documentation.....	1
1.4	Issue and validity of the type approval certificate	1
1.5	Renewal of the type approval certificate	1
1.6	Repetition of the tests	1
2	DEFINITIONS	1
3	PRINCIPAL REQUIREMENTS	1
3.1	General.....	1
3.2	System and components	2

Chapter 2: Test Method for Systems of Ships having a Length ≤ 24 m and with machinery spaces of gross volume up to 140 m³

1	TEST METHOD SYSTEMS OF SHIPS HAVING A LENGTH ≤ 24 M AND MACHINERY SPACES OF GROSS VOLUME UP TO 140 M³	5
1.1	Scope	5
2	SAMPLING	5
3	METHOD OF TEST	5
3.1	Principle.....	5
3.2	Apparatus	5
3.2.1	Test Room	5
3.2.2	Integrity of the test Enclosure.....	5
3.2.3	Engine/Bilge mock-up.....	5
3.3	Instrumentation.....	5
3.4	Nozzles.....	6
3.5	Enclosure temperature.....	6
3.6	Test Fires and Programme for volumes between 80 m ³ and up to 140 m ³	6
3.6.1	Fire Types.....	6
3.6.2	Test Programme	6
3.7	Test Fires and Programme for volumes up to 80 m ³	7
3.7.1	Fire Types.....	7
3.7.2	Test Programme	8
3.8	Extinguishing system.....	8
3.8.1	System installation.....	8
3.8.2	Agent concentration	8

INDEX

3.9	Procedure	9
3.9.1	Fuel level in trays	9
3.9.2	Fuel flow and pressure measurements	9
3.9.3	Ventilation	9
3.9.4	Duration of test	9
3.10	Measurements and observations	9
3.11	Tolerances	9
4	ACCEPTANCE CRITERIA	9
5	TEST REPORT	10

Chapter 3: Test Method for Systems of Ships having a Length > 24 m and with machinery spaces > 140 m³

1	FIRE TEST METHOD FOR FIXED CLEAN AGENT FIRE-EXTINGUISHING SYSTEMS OF SHIPS HAVING A LENGTH L EXCEEDING 24 M OR MACHINERY SPACES EXCEEDING 140 M³	16
1.1	Scope	16
1.2	Test Method	16

Chapter 1 – General Requirements for Approval

1 GENERAL

1.1 Premise

Fixed clean agent fire-extinguishing systems for use in machinery spaces equivalent to the fixed fire-extinguishing systems required by Tasneef Rules, may be accepted on board if Tasneef type approved only.

Systems dealt with in these Rules are also to comply with the applicable requirements given in the specific Tasneef Rules for the vessel where the system will be provided.

The arrangement of the systems on board is subject to the approval of the drawings relevant to the single installation.

Aerosol fire-extinguishing systems consists in the release of a chemical agent, electrically nonconducting and leaving no residue upon evaporation, to extinguish a fire by interruption of the combustion chemical reaction.

1.2 Field of Application

1.2.1 General

These Rules apply to fixed aerosol fire-extinguishing systems for use in machinery spaces of ships and yachts (hereafter referred to simply as ships).

- Chapter 1 applies to all ships.
- Chapter 2 applies to ships having a length L not exceeding 24 m and machinery spaces having a gross volume not exceeding 70 m³.
- Chapter 3 applies to ships having a length L exceeding 24 m or machinery spaces having a gross volume exceeding 70 m³.

L is the length in metres of the full load waterline, measured on the hull plain of symmetry, from the forward side of the stem to the aft side of the sternpost, or transom.

1.2.2 Alternative

As an alternative, at request of the Interested Parties, Tasneef applies the Commission Implementing Regulation (EU) 2020/1170, adopted by the Council on 16 July 2020, including further adoptions, to those ships subject to this Directive.

1.3 Documentation

The request for type approval is to be submitted to Tasneef by the Manufacturer, or by the Applicant if authorized by the Manufacturer, and is to include:

- a) the name of the Manufacturer;
- b) the designation of the system;
- c) a schematic layout of the system;
- d) complete specification of the materials used for all system components;
- e) the installation and maintenance manual;

- f) documentation relevant to previous tests and approvals, if any.

1.4 Issue and validity of the type approval certificate

Subject to the satisfactory outcome of the required checks and tests, Tasneef issues to the manufacturing firm a "Type Approval Certificate" valid for all fixed clean agent fire-extinguishing systems of the same type, dimensions, layout, material, etc., as that subjected to type testing. The validity of the certificate is based on the assumption of the constant conformity of the single products manufactured with the satisfactorily tested prototype. The firm is entirely responsible for such conformity. The Type Approval Certificate may be suspended or cancelled by Tasneef when the conditions on which the type approval was based are no longer fulfilled.

The Type Approval Certificate is valid for five years from the date of issue.

1.5 Renewal of the type approval certificate

In order to renew the Type Approval Certificate, the documentation in [1.3], is to be submitted to Tasneef with indication of any modifications in respect of the previous approval.

On the basis of the review of such documentation, Tasneef will establish the checks and tests to be carried out in order to renew the Type Approval Certificate.

1.6 Repetition of the tests

Tasneef reserves the right to repeat type tests, wholly or in part, in the case of modification of the Rules on the basis of which the type approval was issued or in the event of doubts or complaints.

2 DEFINITIONS

Agent – Medium: For the purpose of these Rules, the terms "agent" and "medium" are interchangeable.

Minimum extinguishing concentration: is the concentration determined by a cup burner test acceptable by Tasneef

Design concentration: is to be not less than 20% above the minimum extinguishing concentration.

3 PRINCIPAL REQUIREMENTS

3.1 General

The minimum extinguishing and design concentrations, are to be verified by the full scale testing described in the following chapters as applicable.

For systems using halocarbon clean agents, 95% of the design concentration is to be discharged in 10 s or less.

Chapter 1 – General Requirements for Approval

For inert gas systems, the discharge time is not to exceed 120 s for 85% of the design concentration.

The quantity of extinguishing agent for the protected space is to be calculated at the minimum expected ambient temperature using the design density based on the net volume of the protected space, including the casing.

The net volume of a protected space is that part of the gross volume of the space which is accessible to the fire-extinguishing agent.

When calculating the net volume of a protected space, this is to include the volume of the bilge, the volume of the casing and the volume of free air contained in air receivers which, in the event of a fire, may be released into the protected space.

The objects that occupy volume in the protected space are to be subtracted from the gross volume of the space. They include, but are not necessarily limited to:

- 1) auxiliary machinery;
- 2) boilers;
- 3) condensers;
- 4) evaporators;
- 5) main engines;
- 6) reduction gears;
- 7) tanks; and
- 8) trunks.

Subsequent modifications to the protected space that alter its net volume shall require the quantity of extinguishing agent to be adjusted accordingly.

No fire suppression agent is to be used which is carcinogenic, mutagenic, or teratogenic at concentrations expected during use. No agent is to be employed in concentrations greater than the cardiac sensitization NOAEL (No Observed Adverse Effect Level), without the use of two separate controls to release the system as follows:

1. one control is to be used to open the valve of piping conveying the medium into the protected space; this control is always the first to be operated;
2. the second control is to be used to open the valve which release the medium from its storage containers and it is always to be the second operated.

In no case, is an agent to be used above its LOAEL (Lowest Observed Adverse Effect Level) or ALC (Approximate Lethal Concentration) calculated on the net volume of the protected space at the maximum expected ambient temperature.

All systems are to be designed to allow evacuation of the protected spaces prior to discharge. Means are also to be provided for automatically giving audible and visual warning of the release of fire-extinguishing medium into any space in which personnel normally work or to which they have access. The alarm should

operate for the period of time necessary to evacuate the space, but not less than 20 s before the medium is released. Unnecessary exposure, even at concentrations below an adverse effect level, is to be avoided.

Even at concentrations below an adverse effect level, exposure to gaseous fire extinguishing agents should not exceed 5 min. Halocarbon agents may be used up to the No Observed Adverse Effect Level (NOAEL) calculated on the net volume of the protected space at the maximum expected ambient temperature without additional safety measures. If a halocarbon agent is to be used above its NOAEL, means should be provided to limit exposure to no longer than the time specified according to a scientifically accepted physiologically based pharmacokinetic* (PBPK) model or its equivalent which clearly establishes safe exposure limits both in terms of extinguishing media concentration and human exposure time.

* Refer to document FP 44/INF.2 – Physiologically based pharmacokinetic model to establish safe exposure criteria for halocarbon fire extinguishing agents.

For inert gas systems, means should be provided to limit exposure to no longer than 5 min for inert gas systems designed to concentrations below 43% (corresponding to an oxygen concentration of 12%, sea level equivalent of oxygen) or to limit exposure to no longer than 3 min for inert gas systems designed to concentrations between 43% and 52% (corresponding to between 12% and 10% oxygen, sea level equivalent of oxygen) calculated on the net volume of the protected space at the maximum expected ambient temperature.

In no case should a halocarbon agent be used at concentrations above the Lowest Observed Adverse Effect Level (LOAEL) nor the Approximate Lethal Concentration (ALC) nor should an inert gas be used at gas concentrations above 52% calculated on the net volume of the protected space at the maximum expected ambient temperature.

Automatic activation of the system may be accepted on a "case-by-case" basis upon the examination of the relevant documentation (electric diagrams, controls, etc.) and, in any case, is admitted for small machinery spaces where personnel cannot have access.

3.2 System and components

The system and its components are to be suitably designed to withstand the ambient temperature changes, vibration, humidity, shock, impact, clogging, electromagnetic compatibility and corrosion normally encountered in machinery spaces.

The system and its components are to be designed, manufactured and installed in accordance with standards acceptable to Tasneef. As a minimum, the

Chapter 1 – General Requirements for Approval

design and installation standards are to cover the following elements:

- a) safety:
 - 1) toxicity;
 - 2) noise, nozzle discharge;
 - 3) decomposition products;
- b) storage container design and arrangement:
 - 1) strength requirements;
 - 2) maximum/minimum fill density, operating temperature range;
 - 3) pressure and weight indication;
 - 4) pressure relief;
 - 5) agent identification and lethal requirements;
- c) agent supply, quantity, quality standards;
- d) pipes and fittings:
 - 1) strength, material properties, fire resistance;
 - 2) cleaning requirements;
- e) valves:
 - 1) test requirements;
 - 2) corrosion resistance;
 - 3) elastomer compatibility;
- f) nozzles:
 - 1) height and area test requirements;
 - 2) corrosion and elevated temperature resistance;
- g) actuation and control systems:
 - 1) test requirements;
 - 2) backup power requirements;
- h) alarms and indicators:
 - 1) pre-discharge alarm, agent discharge alarms and time delays;
 - 2) abort switches;
 - 3) supervisory circuit requirements;
 - 4) warning signs and audible and visual alarms are to be located outside each entry to the relevant space, as appropriate;
 - 5) announcement of faults in cases of electrical activation and alarm system;
- i) agent flow calculation:
 - 1) approval and testing of design calculation method;
 - 2) fitting pressure losses and/or equivalent length;
- j) enclosure integrity and leakage requirements:
 - 1) enclosure leakage;
 - 2) openings;
 - 3) mechanical ventilation interlocks;
- k) design concentration requirements, total flooding quantity;
- l) discharge time; and
- m) inspection, maintenance, service and test requirements.

The nozzle type, maximum nozzle spacing, maximum height and minimum nozzle pressure are to be within

limits tested to provide fire extinction as per the proposed test method.

Provisions are to be made to ensure that escape routes which are exposed to leakage from the protected space are not rendered hazardous during or after discharge of the agent in the event of a fire. In particular, hydrogen fluoride (HF) vapour can be produced in fires as a breakdown product of the fluorocarbon fire extinguishing agents and cause health effects such as upper respiratory tract and eye irritation to the point of impairing escape.

Control stations and other locations that require manning during a fire situation are to have provisions to keep HF and HCl below 5 ppm at that location. The concentrations of other products are to be kept below concentrations considered hazardous for the required duration of exposure.

Where agent containers are stored within a protected space, the containers are to be evenly distributed throughout the space and meet the following provisions:

- a) a manually initiated power release, located outside the protected space, is to be provided. Duplicate sources of power are to be provided for this release and are to be located outside the protected space, and be immediately available;
- b) electric power circuits connecting the containers are to be monitored for fault condition and loss of power. Visual and audible alarms are to be provided to indicate this;
- c) pneumatic, electric or hydraulic power circuits connecting the containers are to be duplicated and widely separated. The sources of pneumatic or hydraulic pressure are to be monitored for loss of pressure. Visual and audible alarms are to be provided to indicate this;
- d) within the protected space, electrical circuits essential for the release of the system are to be fire-resistant according to standard IEC 60331 or other equivalent standards. Piping systems essential for the release of systems designed to be operated hydraulically or pneumatically are to be of steel or other equivalent heat-resisting material to the satisfaction of Tasneef;
- e) each pressure container is to be fitted with an automatic overpressure release device which, in the event of the container being exposed to the effects of fire and the system not being operated, will safely vent the contents of the container into the protected space;
- f) not more than two discharge nozzles are to be fitted to any pressure container and the maximum quantity of agent in each container is to the satisfaction of Tasneef;

Chapter 1 – General Requirements for Approval

- g) the containers are to be monitored for decrease in pressure due to leakage and discharge. Visual and audible alarms in the protected area and on the navigation bridge or in the space where the fire control equipment is centralized are to be provided to indicate this;
- h) the arrangement of containers and electrical circuits and piping essential for the release of any system is to be such that in the event of damage to any one power release line or container valve through mechanical damage, fire or explosion in a protected space, i.e. a single fault concept, at least the amount of agent needed to achieve the minimum extinguishing concentration can still be discharged having regard to the requirement for uniform distribution of medium throughout the space;
- i) the arrangement in respect of systems for spaces requiring less than 6 containers are to be to the satisfaction of Tasneef.

The requirements listed above from a) to g) may be waived for pre-engineered systems, due to the nature and characteristics (e.g. volume or shape) of the protected space at the discretion of Tasneef. In this case a specific note will be introduced on the certificate.

A minimum agent hold time of 15 min is to be provided.

The release of an extinguishing agent may produce significant over and under pressurization in the protected space. Measures to limit the induced pressures to acceptable limits are to be provided.

For all ships, the fire-extinguishing system design manual is to address recommended procedures for the control of products of agent decomposition, including HF vapour generated from fluorocarbon extinguishing agents which could impair escape.

Clearly, longer exposure of the agent to high temperatures would produce greater concentrations of these types of gases.

The type and sensitivity of detection, coupled with the rate of discharge, are to be selected to minimize the exposure time of the agent to the elevated temperature.

The performance of fire-extinguishing arrangements on passenger ships is not to present health hazards from decomposed extinguishing agents; for example on passenger ships, the decomposition products are not to be discharged in the vicinity of muster (assembly) stations. Other mitigating steps include evacuation, and donning masks.

Spare parts and operating and maintenance instructions, including operational tests for the system are to be provided as recommended by the Manufacturer.

Chapter 2 – Test Method for Systems of Ships having a Length ≤ 24 m and with machinery spaces of gross volume up to 140 m³

1 TEST METHOD SYSTEMS OF SHIPS HAVING A LENGTH ≤ 24 M AND MACHINERY SPACES OF GROSS VOLUME UP TO 140 M³

1.1 Scope

This test method is intended for evaluating the extinguishing effectiveness of fixed gas (clean agent) fire-extinguishing systems for the protection of machinery spaces of category A.

The test method is applicable to gases, liquefied gases and mixtures of gases. The test method is not valid for extinguishant gases mixed with compounds in solid or liquid state at ambient conditions.

The test program has two objectives:

- a) establishing the extinguishing effectiveness of a given agent at its tested concentration; and
- b) establishing that the particular agent distribution system puts the agent into the enclosure in such a way as to fully flood the volume to achieve an extinguishing concentration at all points.

2 SAMPLING

The components to be tested are to be supplied by the Manufacturer together with design and installation criteria, operational instructions, drawings and technical data sufficient for the identification of the components.

3 METHOD OF TEST

3.1 Principle

This test procedure enables the determination of the effectiveness of different gaseous agent extinguishing systems against spray fires, pool fires class A fires including polymeric materials fires.

3.2 Apparatus

3.2.1 Test Room

The tests are to be performed in a test room having a gross volume corresponding, as far as practicable, to the maximum volume for which the fire-extinguishing system approval is requested.

In general the test room is to be not less than 20 m³ in gross volume. Standard ISO containers 20' or 40' or combination of containers to increase the room volume may also be accepted. In the case of combination of containers, the final layout of the test room is to consist in a single open room, with no separations between one container module and the other. The test room is to be provided with a closable access door measuring approximately 4 m² in area.

Taking into consideration the previously mentioned over and under pressurization the release of an

extinguishing medium may produce, suitable means (or procedures) to safely equilibrate the pressure, as well as dissipate the accumulated heat, prior to access again the test room, are to be provided.

Test room layouts other than those specified above may be accepted on "case-by-case" basis.

3.2.2 Integrity of the test Enclosure

The test enclosure is to be nominally leaktight when doors and hatches are closed.

The integrity of seals on doors, hatches and other penetrations (e.g., instrumentation access ports) is to be verified before each test.

3.2.3 Engine/Bilge mock-up

- a) An engine mock-up is to be constructed in steel, plate, thickness at least 3 mm, with sizes (width x length x height) 1.0 x 1.8 m x 1.4 m. The mock-up is to be fitted with two steel tubes diameter 0.25 m and 1.8 m length, that simulate exhaust manifolds, and a solid steel plate on top as per figures. Spray (C) is to be placed below the overhanging steel plate on top of the mock-up (see Fig 1, Fig 2 and Fig 3 (not in scale)) for test enclosure having volume V from 80 m³ up to 140 m³. For volumes up to 80 m³, see Fig 4 and Fig 5 (out of scale).
- b) A bilge system is to be created by a floor plate system located close to the sides of the engine mock-up with a wall around, fitted to the floor of test room: fuel trays placed underneath the engine simulate fuel accumulation (hidden pool fire) and open pool fire.
- c) Provisions are to be made for placement of the fuel trays, as described in Tab 1 (Volume > 80 m³) and Tab 3 (Volume ≤ 80 m³), and located as described in figures.
- d) Polymeric sheets installed in suitable racks as per Fig 6 and Fig 7 are to be provided.

3.3 Instrumentation

The following measurements are to be made:

- a) continuous temperature monitoring of the generator casing;
- b) continuous temperature monitoring of the generator discharge stream measured at 0,5 m, 1,0 m and 2,0 m away from the discharge ports;
- c) continuous temperature monitoring at three vertical positions (e.g. 1 m, 2,5 m, etc.);
- d) enclosure pressure;
- e) oxygen analysis, at mid-room height, before the test;
- f) means of determining flame-out indicators;
- g) fuel nozzle pressure in the case of spray fires;
- h) fuel flow rate in the case of spray fires; and

Chapter 2 – Test Method for Systems of Ships having a Length ≤ 24 m and with machinery spaces of gross volume up to 140 m³

i) means for determining discharge duration (discharge test to be conducted before fire test, e.g. visual examination through suitable window).

for the calculation of the concentration that the agent would be expected to achieve at that temperature and with that agent weight applied in the test volume.

3.4 Nozzles

- a) For test purposes, nozzles are to be located as recommended by the manufacturer.
- b) If more than one nozzle is used, they are to be symmetrically located.

3.6 Test Fires and Programme for volumes between 80 m³ and up to 140 m³

3.6.1 Fire Types

The test programme, as described in Tab 3, should employ test fires as described in Tab 1 and Tab 2 below.

3.5 Enclosure temperature

The ambient temperature of the test enclosure at the start of the test is to be noted and serves as the basis

Table 1: Parameters of test fires

Fire	Type	Fuel	Fire size, MW	Remarks
A	76 – 100 mm ID cup	Heptane	0.0012 to 0.002	Tell tale
B	0.25 m ² tray	Heptane	0.35	
C	0.70 m ² tray	Diesel/fuel oil	1	(1)
D	3 m ² tray	Diesel/fuel oil	4.4	
E	Low pressure, low flow spray	Heptane 0.03 ± 0.005 kg/s	1.1	
F	Wood crib	Spruce or fir	0.3	(2)
G	0.10 m ² tray	Heptane	0.14	
H	Polymeric sheets	PMMA, Polypropylene, ABS		(3)

1) Diesel/Fuel oil means light diesel or commercial fuel oil.
 2) The wood crib consists of six members of trade size 50 mm x 50 mm x 450 mm, kiln dried spruce or fir lumber having a moisture content between 9 and 13%. The members should be placed in alternate layers at right angles to one another. Members should be evenly spaced forming a square structure. Ignition of the crib should be achieved by burning commercial grade heptane in a square steel tray 0.25 m² in area. During the pre-burn period the crib should be placed centrally above the top of the tray at a distance of 300 to 600 mm.
 3) For the polymeric sheet fire test see [3.2.3] d).

Table 2: Spray fire test parameters

Fire type	Low pressure, Low flow (E)
Spray nozzle	Wide spray angle (80°) Full cone type
Nominal fuel pressure	8.5 bar
Fuel flow	0.03 ± 0.005 kg/s
Fuel temperature	20 ± 5 °C
Nominal heat release rate	1.1 ± 0.1 MW

3.6.2 Test Programme

- a) The fire test programme is to foresee single test fires or in combination, as outlined in Tab 3 below.
- b) All applicable tests of Tab 3 are to be conducted for every new fire-extinguishing media.
- c) In the case of new nozzles/distribution system equipment (hardware) for systems employing fire-extinguishing media that have successfully completed the requirements of [3.6.1].

minimum extinguishing concentration can be below minimum cup burner test extinguishing concentration accepted by Tasneef according to internationally recognized standards.

- d) Polymeric sheets are to be arranged in three racks (one for each polymeric material) containing 4 sheets each as per Fig 6 and Fig 7.

A test with fire class A only is required to evaluate the minimum extinguishing medium concentration declared by the manufacturer. In no case the

Chapter 2 – Test Method for Systems of Ships having a Length ≤ 24 m and with machinery spaces of gross volume up to 140 m³

Table 3: Test programme

Test No.	Fire combination (see table 1)
1	A: Tell tales, 8 corners. (1)
2	B: 0.25 m ² heptane tray under mock-up G: 0.10 m ² heptane tray on deck plate located below solid steel obstruction plate Total fire load: 0.49 MW
3	C: 0.70 m ² diesel/fuel oil tray on deck plate located below solid steel obstruction plate F: Wood crib positioned as in Fig 2 E: Low pressure, low flow horizontal spray – concealed – with impingement on inside of engine mock-up wall. H: Polymeric sheets positioned as in Fig 2 Total fire load: 3.4 MW (C+F+E)
4	D: 3 m ² diesel tray under engine mock-up Total fire load: 4.4 MW
(1) Tell-tale fire cans should be located as follows: a. in upper corners of enclosure 150 mm below ceiling and 50 mm from each wall; and b. in corners on floors 50 mm from walls.	

3.7 Test Fires and Programme for volumes up to 80 m³

3.7.1 Fire Types

The test programme as described in Tab 6, is to be performed according to test fires as described in Tab 4 and Tab 5 below.

Table 4: Parameters of test fires up to 80 m³

Ref.	Fire	Constituents	Q.ty	Container type	Container size
CUPS	Cups 1-8	Heptane	0.3 l/ cup one at each angle of the room	Open tin approx. 100 mm diameter	100 mm x 100 mm = 0.75 l
A	Tray A	Engine lube oil Diesel fuel oil (1)	3.5 l 1.5 l	Steel tray	1000 cm x 500 cm = 0.5 m ²
B	Tray B	Diesel fuel oil (1) Heptane:	10 l 0.25 l	Steel tray	1200 cm x 800 cm = 0.96 m ²
C	Spray C	Hidden spray fire – Diesel fuel oil (1)	1.1 l/min	Pressurized container at 3 bar pressure	
D	Wood crib	Spruce or fir			
E	Polymeric sheets	PMMA, Polypropylene, ABS			
<p>(1) Diesel/Fuel oil means light diesel or commercial fuel oil. (2) The wood crib consists of six members of trade size 50 mm x 50 mm x 450 mm, kiln dried spruce or fir lumber having a moisture content between 9 and 13%. The members should be placed in alternate layers at right angles to one another. Members should be evenly spaced forming a square structure. Ignition of the crib should be achieved by burning commercial grade heptane in a square steel tray 0.25 m² in area. During the pre-burn period the crib should be placed centrally above the top of the tray at a distance of 300 to 600 mm. (3) The polymeric sheet fire test arrangement see [3.6.2] d).</p>					

Chapter 2 – Test Method for Systems of Ships having a Length ≤ 24 m and with machinery spaces of gross volume up to 140 m^3

Table 5: Spray fire test parameters up to 80 m^3

Fire type	Spray fire (C)
Spray nozzle	Wide spray angle (80°) Full cone type
Nominal fuel pressure	8.5 bar
Fuel flow	$0.03 \pm 0.005 \text{ kg/s}$
Fuel temperature	$20 \pm 5 \text{ }^\circ\text{C}$
Nominal heat release rate	$1.1 \pm 0.1 \text{ MW}$

Table 6: Test programme up to 80 m^3

Test No.	Fire combination (see Tab 1 for fire specification)
1	CUPS+B (1)
2	A+C+D
3	A+C+E
4	CUPS+A+B+C (1)
(1) Tell-tale fire cups should be located as follows: <ul style="list-style-type: none"> • in upper corners of enclosure 150 mm below ceiling and 50 mm from each wall; and • in corners on floors 50 mm from walls. 	

3.7.2 Test Programme

- The fire tests programme is to be performed as outlined in Tab 6.
- All applicable tests of Tab 6 are to be conducted for every new fire-extinguishing media.
- In the case of new nozzles/distribution system equipment (hardware) for systems employing fire-extinguishing media that have successfully completed the requirements of [3.6.3], a test with fire CUPS only is required to verify the minimum extinguishing medium concentration declared by the manufacturer. In no case the minimum extinguishing concentration can be below minimum cup burner test extinguishing concentration accepted by Tasneef according to internationally recognized standards.
- Polymeric sheets are to be arranged in one rack containing 3 polymeric sheets (one for each polymeric material). Rack construction is to be as per Fig 6 and Fig 7.

3.8 Extinguishing system

3.8.1 System installation

The extinguishing system tested under [3.6] and [3.7] is to be installed according to the Manufacturer's design and installation instructions.

3.8.2 Agent concentration

- Design concentration
The agent design concentration is that concentration (in volume per cent) required by the system Designer for the fire protection application.
 - Test concentration
The concentration of agent to be used in the fire-extinguishing tests is to be the design concentration specified by the extinguishing system Manufacturer, except for Test 1 which is to be conducted at 77% of the manufacturer's recommended design concentration but in no case less than the cup burner extinguishing concentration acceptable to Tasneef in accordance with international recognized Standards.
- c) Quantity of Agent
The quantity of agent to be used is to be determined as follows:
- Halogenated agents

$$W = (V/S) C C / (100 - C)$$
 where:
 W = agent mass, kg
 V = volume of test enclosure, m^3
 S = agent vapor specific volume at temperature and pressure of the test enclosure, kg/m^3
 C = gaseous agent concentration, volume per cent.
 - Inert gas agents

$$Q = V [294 / (273 + T)] C (P / 1.013) C \ln [100 / (100 - C)]$$

Chapter 2 – Test Method for Systems of Ships having a Length ≤ 24 m and with machinery spaces of gross volume up to 140 m^3

where:

Q = volume of inert gas, measured at 294 K and 1.013 bar, discharged, m^3

V = volume of test enclosure, m^3

T = test enclosure temperature, Celsius degrees

P = test enclosure pressure, bar

C = gaseous agent concentration, volume per cent.

3.9 Procedure

3.9.1 Fuel level in trays

The trays used in the test are to be filled with at least 30 mm fuel on a water base. Freeboard is to be 120 +/- 10 mm.

3.9.2 Fuel flow and pressure measurements

For spray fires, the fuel flow and pressure are to be measured before and during each test.

3.9.3 Ventilation

a) Pre-burn period

During the pre-burn period the test enclosure is to be well ventilated. The oxygen concentration, as measured at mid-room height, is to be not less than 20 volume per cent at the time of system discharge.

b) End of pre-burn period

Doors and other ventilation openings are to be closed at the end of the pre-burn period.

3.9.4 Duration of test

a) Pre-burn time

Fires are to be ignited such that the following burning times occur before the start of agent discharge:

- 1) sprays – 5 to 15 s
- 2) trays – 2 min
- 3) wood crib - 4 min; and
- 4) polymeric sheets – 210 s.

b) Discharge time

- 1) halogenated agents are to be discharged at a rate sufficient to achieve delivery of 95% of the minimum design quantity in 10 s or less;
- 2) inert gas agents are to be discharged at a rate sufficient to achieve 85% of the minimum design quantity in 120 s or less.

c) Hold period

After the end of agent discharge, the test enclosure is to be kept closed for 15 min.

The test is to involve the attempted ignition of two of the tell-tale fire containers. One container is to be at the floor level and the other at the ceiling level at the diagonally opposite corner. At 10 min after extinguishment of the fires, a remotely operated electrical ignition source is to be energized for at least 10 s at each container. The test is to be repeated at one min intervals four more times, the last at 14 min after extinguishment. Sustained burning for 30 s or

longer of any of these ignition attempts constitutes a re-ignition test failure.

3.10 Measurements and observations

a) Before test

- 1) temperature of test enclosure, fuel and engine mockup;
- 2) initial weights of agent containers;
- 3) verification of integrity agent distribution system and nozzles;
- 4) initial weight of wood crib.

b) During test

- 1) start of the ignition procedure;
- 2) start of the test (ignition);
- 3) time when ventilating openings are closed;
- 4) time when the extinguishing system is activated;
- 5) time from end of agent discharge;
- 6) time when the fuel flow for the spray fire is shut off;
- 7) time when all fires are extinguished;
- 8) time of re-ignition, if any, during hold period;
- 9) time at end of hold time;
- 10) at the start of the test, initiate continuous monitoring as per [3.3].

c) After test

- 1) weight of agent containers;
- 2) verification that the bottom of trays is covered by fuel;
- 3) final weight of wood crib.

3.11 Tolerances

Unless otherwise stated, the following tolerances are to apply:

- a) length $\pm 2\%$ of value;
- b) volume $\pm 5\%$ of value;
- c) pressure $\pm 3\%$ of value;
- d) temperature $\pm 5\%$ of value; and
- e) concentration $\pm 5\%$ of value.

4 ACCEPTANCE CRITERIA

4.1

Class B fires are to be extinguished within 30 s of the end of discharge. At the end of the hold period there is to be no re-ignition upon opening the enclosure.

4.2

The fuel spray is to be shut off 15 s after extinguishments. At the end of the hold time, the fuel spray is to be restarted for 15 s prior to re-opening the door and there is to be no re-ignition.

4.3

The ends of the test fuel trays are to contain sufficient fuel to cover the bottom of the tray.

Chapter 2 – Test Method for Systems of Ships having a Length ≤ 24 m and with machinery spaces of gross volume up to 140 m³

- 4.4**
The wood crib weight loss should be no more than 50% at the end of the test.
- 4.5**
When performing the re-ignition test as per [3.9.4] a) a fire sustained burning for 30 s or longer of any of the re-ignition attempts constitute a re-ignition test failure.
- 4.6**
For the polymeric sheets, the test is satisfactory when no flaming is present 60 s after end of discharge and no re-ignition after 10 min from end of discharge and no re-ignition happens when opening the test room.
- 4.7**
The extinguishing medium concentration used for the successful performance of the tests is to be measured considering the net volume of the test enclosure. The design concentration is to be 1.3 times the measured extinguishing medium concentration.
- 4.8**
In the case that the manufacturer provides pre-engineered systems for smaller volumes, based on a larger volume tested, the extinguishing concentration for a gross volume (V_g) is to be calculated on the basis of the design concentration determined with the test, taking into account a net volume calculated as 80% of V_g .
- b) date and identification number of the test report;
c) name and address of the client;
d) purpose of the test;
e) name and address of the Manufacturer or Supplier of the product;
f) name or other identification marks of the product;
g) description of the tested product;
1) drawings;
2) technical descriptions;
3) assembly instructions;
4) specification of included materials; and
5) detailed drawing of test set-up;
h) date of supply of the product;
i) date of test;
j) test method;
k) drawing of each test configuration;
l) identification of the test equipment and used instruments;
m) conclusions;
n) deviations from the test method, if any;
o) test results including measurements and observations;
p) during and after the test; and
q) date and signature.

5 TEST REPORT

- The test report is to include the following information:
a) name and address of the test laboratory;

Figure 1

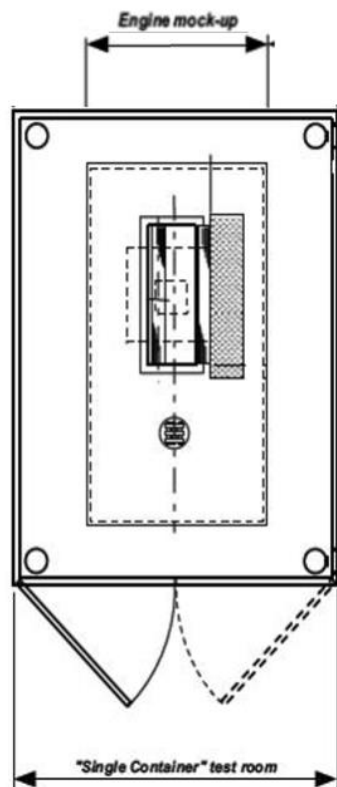
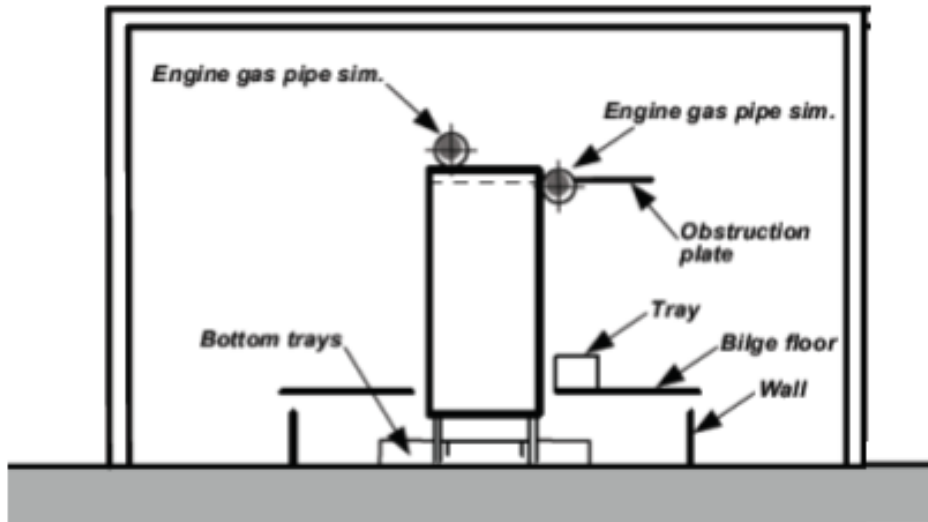

Chapter 2 – Test Method for Systems of Ships having a Length ≤ 24 m and with machinery spaces of gross volume up to 140 m^3

Figure 2

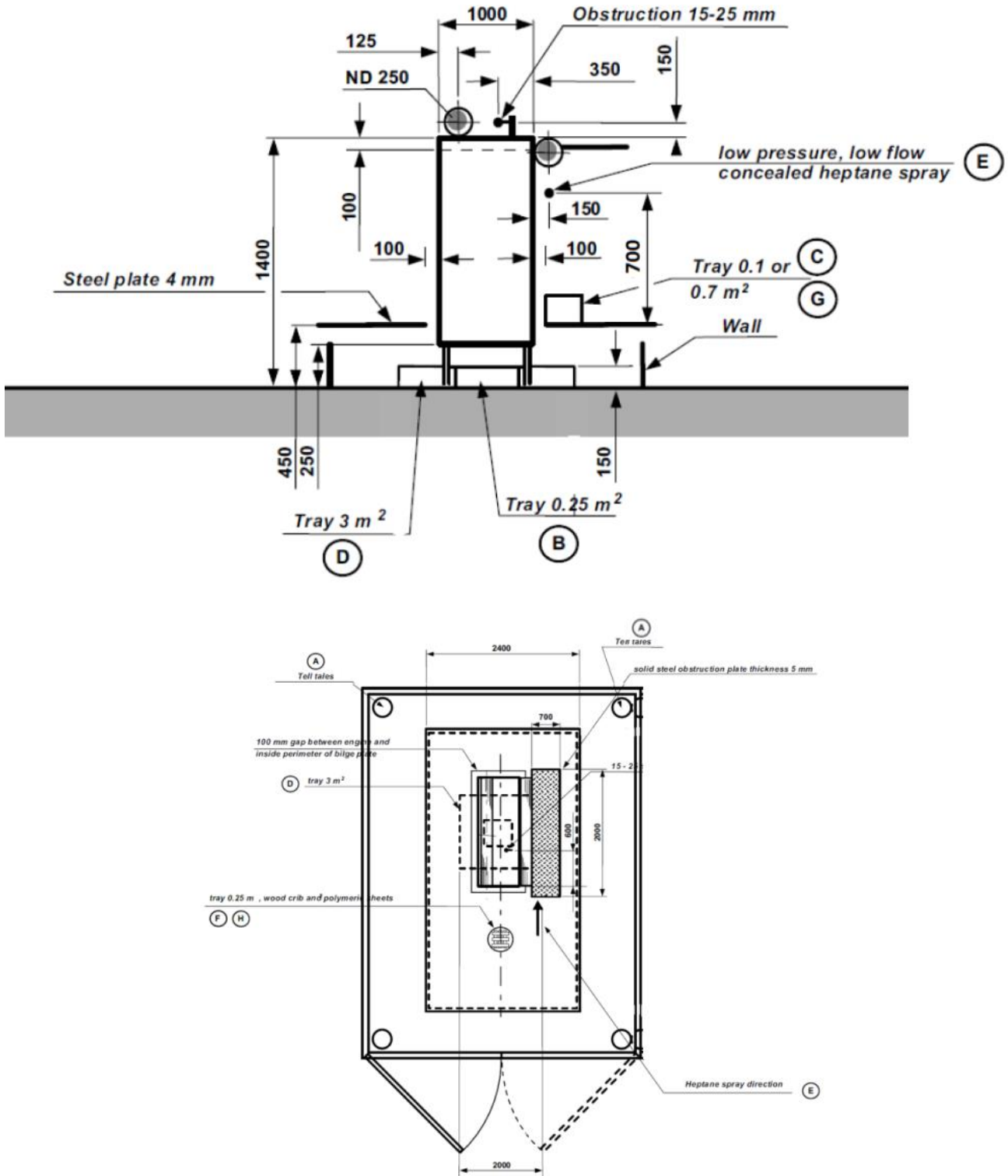

Figure 3

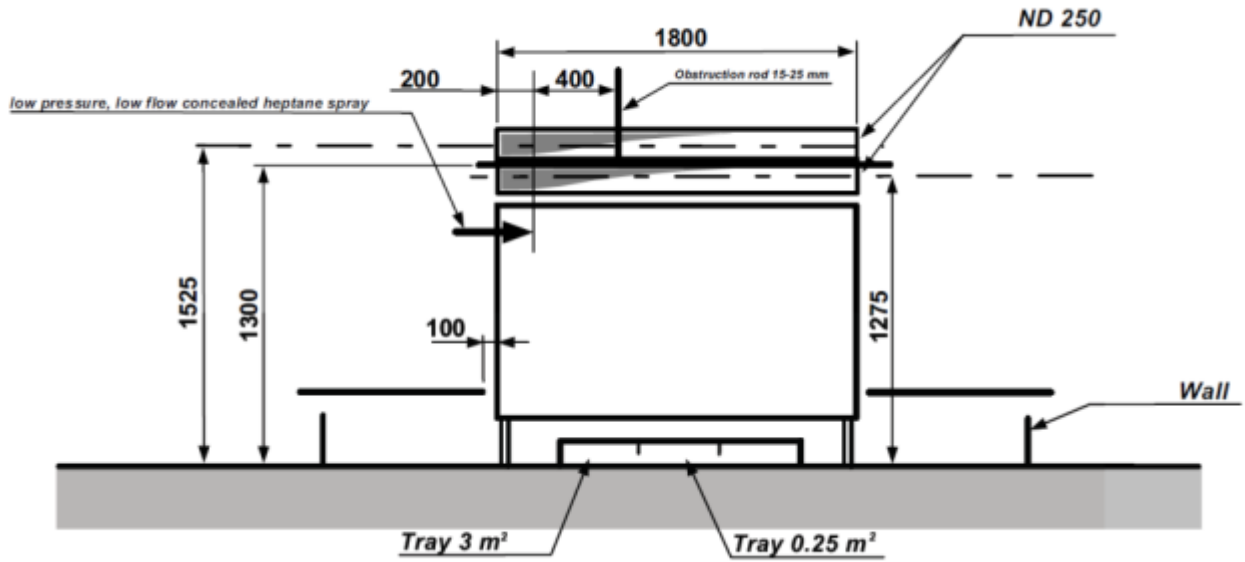
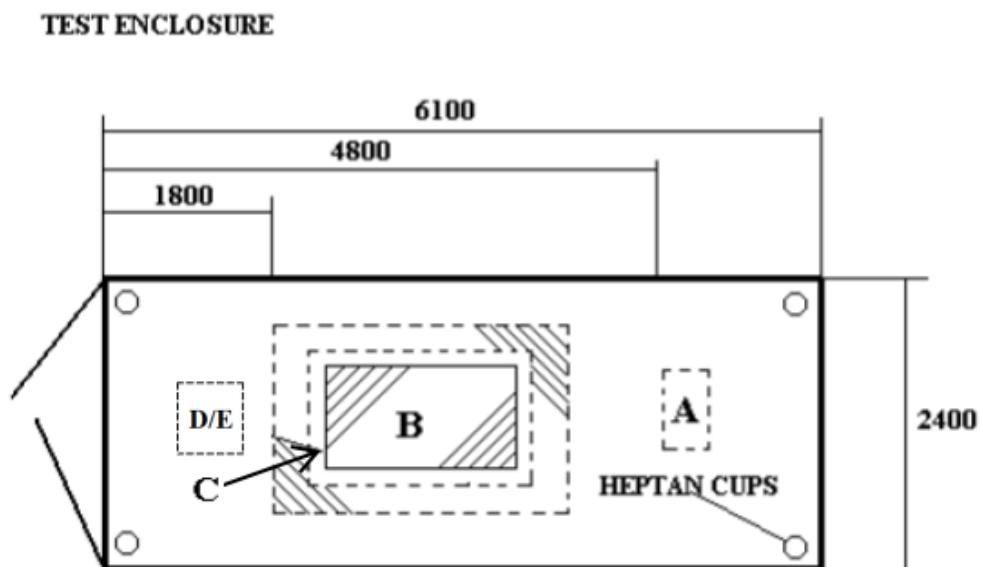
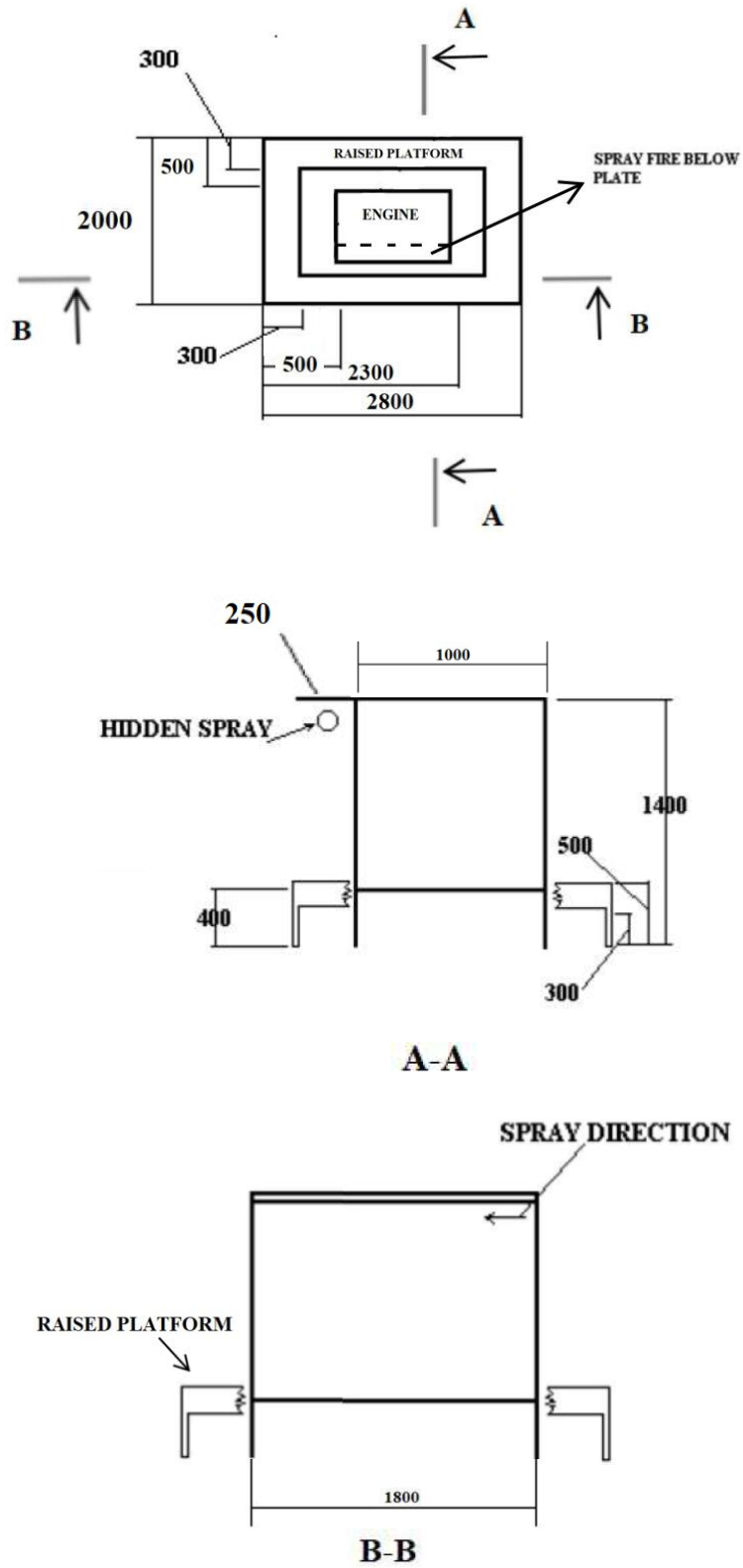

Figure 4



Chapter 2 – Test Method for Systems of Ships having a Length ≤ 24 m and with machinery spaces of gross volume up to 140 m^3

Figure 5: Engine mock-up



Chapter 2 – Test Method for Systems of Ships having a Length ≤ 24 m and with machinery spaces of gross volume up to 140 m³

Figure 6: Polymeric sheets fire test arrangement

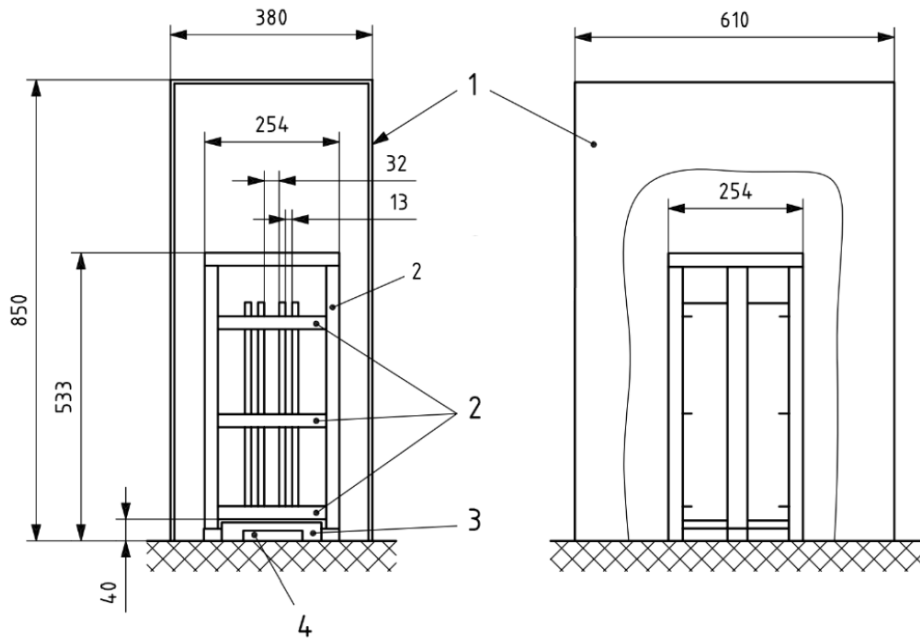

- 1. Steel box open at two ends, closed on the sides and on top
- 2. Steel angle bars for polymeric sheets positioning

Figure 7: Supporting frame for polymeric sheets

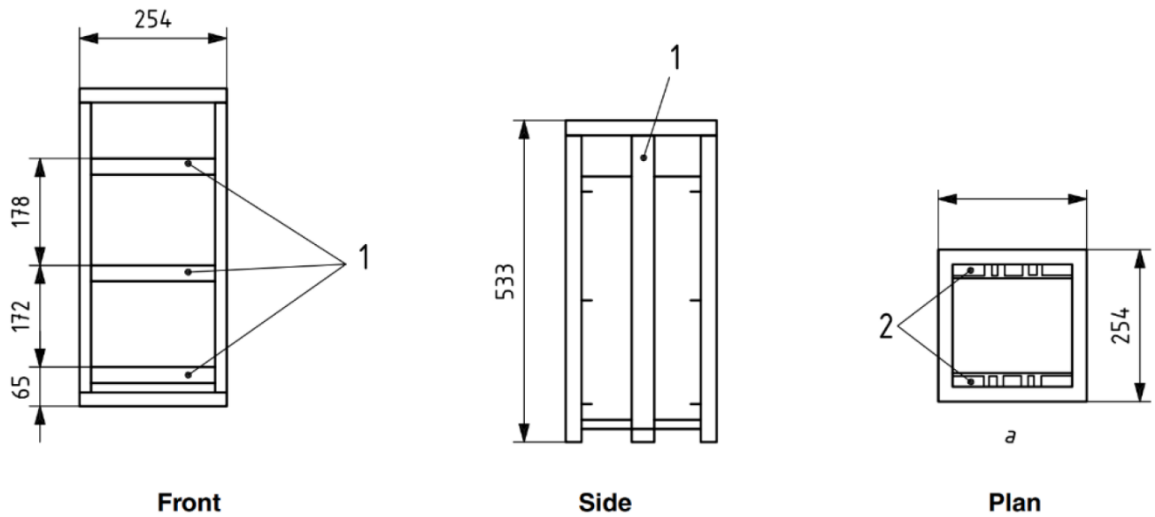

Chapter 3 – Test Method for Systems of Ships having a Length > 24 m and with machinery spaces > 140 m³

1 FIRE TEST METHOD FOR FIXED CLEAN AGENT FIRE-EXTINGUISHING SYSTEMS OF SHIPS HAVING A LENGTH L EXCEEDING 24 M OR MACHINERY SPACES EXCEEDING 140 M³

1.1 Scope

This test method is intended to evaluate the extinguishing effectiveness of fixed aerosol fire-extinguishing systems for the protection of machinery spaces of ships having a length exceeding 24 m or having machinery spaces with a volume exceeding 140 m³.

1.2 Test Method

The test is to be carried out in accordance with IMO MSC/Circ.848 and MSC.1/Circ.1267.