

Rules for the Classification of Ships

Effective from 1 July 2024

Part E

Service Notations



GENERAL CONDITIONS

Definitions:

Administration means the Government of the State whose flag the ship is entitled to fly or under whose authority the ship is authorized to operate in the specific case.

“IACS” means the International Association of Classification Societies.

“Interested Party” means the party, other than the Society, having an interest in or responsibility for the Ship, product, plant or system subject to classification or certification (such as the owner of the Ship and his representatives, the shipbuilder, the engine builder or the supplier of parts to be tested) who requests the Services or on whose behalf the Services are requested.

“Owner” means the registered owner, the shipowner, the manager or any other party with the responsibility, legally or contractually, to keep the ship seaworthy or in service, having particular regard to the provisions relating to the maintenance of class laid down in Part A, Chapter 2 of the Rules for the Classification of Ships or in the corresponding rules indicated in the Specific Rules.

“Rules” in these General Conditions means the documents below issued by the Society:

- (i) Rules for the Classification of Ships or other special units.
- (ii) Complementary Rules containing the requirements for product, plant, system and other certification or containing the requirements for the assignment of additional class notations;
- (iii) Rules for the application of statutory rules, containing the rules to perform the duties delegated by Administrations.
- (iv) Guides to carry out particular activities connected with Services;
- (v) Any other technical document, for example, rule variations or interpretations.

“Services” means the activities described in paragraph 1 below, rendered by the Society upon request made by or on behalf of the Interested Party.

“Ship” means ships, boats, craft and other special units, for example, offshore structures, floating units and underwater craft.

“Society” or **“TASNEEF”** means TASNEEF Maritime

“Surveyor” means technical staff acting on behalf of the Society in performing the Services.

“Force Majeure” means damage to the ship; unforeseen inability of the Society to attend the ship due to government restrictions on right of access or movement of personnel; unforeseeable delays in port or inability to discharge cargo due to unusually lengthy periods of severe weather, strikes or civil strife; acts of war; or other force majeure.

1. Society Roles

1.1. The purpose of the Society is, among others, the classification and certification of ships and the certification of their parts and components. In particular, the Society:

- (i) sets forth and develops Rules.
- (ii) publishes the Register of Ships.
- (iii) Issues certificates, statements and reports based on its survey activities.

1.2. The Society also takes part in the implementation of national and international rules and standards as delegated by various Governments.

1.3. The Society carries out technical assistance activities on request and provides special services outside the scope of classification, which is regulated by these general conditions unless expressly excluded in the particular contract.





2. Rule Development, Implementation and Selection of Surveyor

2.1. The Rules developed by the Society reflect the level of its technical knowledge at the time they are published therefore, the Society, although also committed through its research and development services to continuous updating of the Rules, does not guarantee the Rules meet state-of-the-art science and technology at the time of publication or that they meet the Society's or others' subsequent technical developments.

2.2. The Interested Party is required to know the Rules based on which the Services are provided. With particular reference to Classification Services, special attention is to be given to the Rules concerning class suspension, withdrawal and reinstatement. In case of doubt or inaccuracy, the Interested Party is to promptly contact the Society for clarification. The Rules for Classification of Ships are published on the Society's website: www.tasneef.ae.

2.3. Society exercises due care and skill:

(i) In the selection of its Surveyors

(ii) In the performance of its Services, taking into account the level of its technical knowledge at the time the Services are performed.

2.4. Surveys conducted by the Society include, but are not limited to, visual inspection and non-destructive testing. Unless otherwise required, surveys are conducted through sampling techniques and do not consist of comprehensive verification or monitoring of the Ship or the items subject to certification. The surveys and checks made by the Society on board ship do not necessarily require the constant and continuous presence of the Surveyor. The Society may also commission laboratory testing, underwater inspection and other checks carried out by and under the responsibility of qualified service suppliers. Survey practices and procedures are selected by the Society based on its experience and knowledge and according to generally accepted technical standards in the sector.

3. Class Report & Interested Parties Obligation

3.1. The class assigned to a Ship, like the reports, statements, certificates or any other document or information issued by the Society, reflects the opinion of the Society concerning compliance, at the time the Service is provided, of the Ship or product subject to certification, with the applicable Rules (given the intended use and within the relevant time frame). The Society is under no obligation to make statements or provide information about elements or facts which are not part of the specific scope of the Service requested by the Interested Party or on its behalf.

3.2. No report, statement, notation on a plan, review, Certificate of Classification, document or information issued or given as part of the Services provided by the Society shall have any legal effect or implication other than a representation that, on the basis of the checks made by the Society, the Ship, structure, materials, equipment, machinery or any other item covered by such document or information meet the Rules. Any such document is issued solely for the use of the Society, its committees and clients or other duly authorized bodies and no other purpose. Therefore, the Society cannot be held liable for any act made or document issued by other parties based on the statements or information given by the Society. The validity, application, meaning and interpretation of a Certificate of Classification, or any other document or information issued by the Society in connection with its Services, is governed by the Rules of the Society, which is the sole subject entitled to make such interpretation. Any disagreement on technical matters between the Interested Party and the Surveyor in the carrying out of his functions shall be raised in writing as soon as possible with the Society, which will settle any divergence of opinion or dispute.

3.3. The classification of a Ship or the issuance of a certificate or other document connected with classification or certification and in general with the performance of Services by the Society shall have the validity conferred upon it by the Rules of the Society at the time of the assignment of class or issuance of the certificate; in no case shall it amount to a statement or warranty of seaworthiness, structural integrity, quality or fitness for a particular purpose or service of any Ship, structure, material, equipment or machinery inspected or tested by the Society.

3.4. Any document issued by the Society about its activities reflects the condition of the Ship or the subject of certification or other activity at the time of the check.

3.5. The Rules, surveys and activities performed by the Society, reports, certificates and other documents issued by the Society are in no way intended to replace the duties and responsibilities of other parties such as Governments, designers, shipbuilders, manufacturers, repairers, suppliers, contractors or sub-contractors, Owners, operators, charterers, underwriters, sellers or intended buyers of a Ship or other product or system surveyed.





These documents and activities do not relieve such parties from any fulfilment, warranty, responsibility, duty or obligation (also of a contractual nature) expressed or implied or in any case incumbent on them, nor do they confer on such parties any right, claim or cause of action against the Society. With particular regard to the duties of the ship Owner, the Services undertaken by the Society do not relieve the Owner of his duty to ensure proper maintenance of the Ship and ensure seaworthiness at all times. Likewise, the Rules, surveys performed, reports, certificates and other documents issued by the Society are intended neither to guarantee the buyers of the Ship, its components or any other surveyed or certified item, nor to relieve the seller of the duties arising out of the law or the contract, regarding the quality, commercial value or characteristics of the item which is the subject of transaction.

In no case, therefore, shall the Society assume the obligations incumbent upon the above-mentioned parties, even when it is consulted in connection with matters not covered by its Rules or other documents.

In consideration of the above, the Interested Party undertakes to relieve and hold harmless the Society from any third-party claim, as well as from any liability about the latter concerning the Services rendered.

Insofar as they are not expressly provided for in these General Conditions, the duties and responsibilities of the Owner and Interested Parties concerning the services rendered by the Society are described in the Rules applicable to the specific service rendered.

4. Service Request & Contract Management

4.1. Any request for the Society's Services shall be submitted in writing and signed by or on behalf of the Interested Party. Such a request will be considered irrevocable as soon as received by the Society and shall entail acceptance by the applicant of all relevant requirements of the Rules, including these General Conditions. Upon acceptance of the written request by the Society, a contract between the Society and the Interested Party is entered into, which is regulated by the present General Conditions.

4.2 In consideration of the Services rendered by the Society, the Interested Party and the person requesting the service shall be jointly liable for the payment of the relevant fees, even if the service is not concluded for any cause not pertaining to the Society. In the latter case, the Society shall not be held liable for non-fulfilment or partial fulfilment of the Services requested.

4.3 The contractor for the classification of a ship or for the services may be terminated and any certificates revoked at the request of one of the parties, subject to at least 30/60/90 days' notice, to be given in writing. Failure to pay, even in part, the fees due for services carried out by the society will entitle the society to immediately terminate the contract and suspend the service.

For every termination of the contract, the fees for the activities performed until the time of the termination shall be owned to the society as well as the expenses incurred in view of activities already programmed, this is without prejudice to the right to compensation due to the society as a consequence of the termination.

With particular reference to ship classification and certification, unless decided otherwise by the society, termination of the contract implies that the assignment of class to a ship is withheld or, if already assigned, that it is suspended or withdrawn, any statutory certificates issued by society will be withdrawn in those cases where provided for by agreements between the society and the flag state.

5. Service Accuracy

5.1. In providing the Services, as well as other correlated information or advice, the Society, its Surveyors, servants or agents operate with due diligence for the proper execution of the activity. However, considering the nature of the activities performed (see **Rule Development, Implementation and Selection of Surveyor 2.4**), it is not possible to guarantee absolute accuracy, correctness and completeness of any information or advice supplied. Express and implied warranties are specifically disclaimed.





6. Confidentiality & Document sharing

6.1. All plans, specifications, documents and information provided by, issued by, or made known to the Society, in connection with the performance of its Services, will be treated as confidential and will not be made available to any other party other than the Owner without authorization of the Interested Party, except as provided for or required by any applicable international, European or domestic legislation, Charter or other IACS resolutions, or order from a competent authority. Information about the status and validity of class and statutory certificates, including transfers, changes, suspensions, withdrawals of class, recommendations/conditions of class, operating conditions or restrictions issued against classed ships and other related information, as may be required, may be published on the website or released by other means, without the prior consent of the Interested Party.

Information about the status and validity of other certificates and statements may also be published on the website or released by other means, without the prior consent of the Interested Party.

6.2. Notwithstanding the general duty of confidentiality owed by the Society to its clients in clause 7.1 below, the Society's clients hereby accept that the Society may participate in the IACS Early Warning System which requires each Classification Society to provide other involved Classification Societies with relevant technical information on serious hull structural and engineering systems failures, as defined in the IACS Early Warning System (but not including any drawings relating to the ship which may be the specific property of another party), to enable such useful information to be shared and used to facilitate the proper working of the IACS Early Warning System. The Society will provide its clients with written details of such information sent to the involved Classification Societies.

6.3. In the event of transfer of class, addition of a second class or withdrawal from a double/dual-class, the Interested Party undertakes to provide or to permit the Society to provide the other Classification Society with all building plans and drawings, certificates, documents and information relevant to the classed unit, including its history file, as the other Classification Society may require for classification in compliance with the applicable legislation and relative IACS Procedure. It is the Owner's duty to ensure that, whenever required, the consent of the builder is obtained about the provision of plans and drawings to the new Society, either by way of the appropriate stipulation in the building contract or by other agreement.

In the event that the ownership of the ship, product or system subject to certification is transferred to a new subject, the latter shall have the right to access all pertinent drawings, specifications, documents or information issued by the Society or which has come to the knowledge of the Society while carrying out its Services, even if related to a period prior to transfer of ownership.

7. Health, Safety & Environment

7.1. The clients such as the designers, shipbuilders, manufacturers, repairers, suppliers, contractors or sub-contractors, or other product or system surveyed who have a registered office in ABU Dhabi; should have an approved OSHAD as per Abu Dhabi OHS Centre, or, if they do not need to have an approved OSHAD, they shall comply with TASNEEF standards and have procedures in place to manage the risks from their undertakings.

7.2. For the survey, audit and inspection activities onboard the ship, the ship's owner, the owner representative or the shipyard must follow TASNEEF rules regarding the safety aspects.

8. Validity of General Conditions

8.1. Should any part of these General Conditions be declared invalid, this will not affect the validity of the remaining provisions.





9. Force Majeure

9.1 Neither Party shall be responsible to the other party for any delay or failure to carry out their respective obligations insofar as such delay and failure derives, directly or indirectly, and at any time, from force majeure of any type whatsoever that lies outside the control of either Party.

9.2 The Party that is unable to fulfil the agreement due to Force Majeure shall inform the other party without delay and in all cases within 7 days from when such force majeure arose.

9.3 It is understood that if such force majeure continues for more than 30 days, the Party not affected by the event may terminate this agreement by registered letter. The rights matured until the day in which the force majeure occurred remain unaffected.

10. Governing Law and Jurisdiction

This Agreement shall be governed by and construed in accordance with the laws of Abu Dhabi and the applicable Federal Laws of the UAE.

Any dispute arising out of or in accordance with this Agreement shall be subject to the exclusive jurisdiction of the Abu Dhabi courts.

11. Code of Business conduct

The **CLIENT** declares to be aware of the laws in force about the responsibility of the legal persons for crimes committed in their interest or to their own advantage by persons who act on their behalf or cooperate with them, such as directors, employees or agents.

In this respect, the **CLIENT** declares to have read and fully understood the "**Ethical Code**" published by **TASNEEF** and available in the **TASNEEF** Web site.

The **CLIENT**, in the relationships with **TASNEEF**, guarantees to refrain from any behaviour that may incur risk of entry in legal proceedings for crimes or offences, whose commission may lead to the enforcement of the laws above.

The **CLIENT** also acknowledges, in case of non-fulfilment of the previous, the right of **TASNEEF** to unilaterally withdraw from the contract/agreement even if there would be a work in progress situation or too early terminate the contract/agreement. It's up to **TASNEEF** to choose between the two above mentioned alternatives, and in both cases a registered letter will be sent with a brief sum-up of the circumstances or of the legal procedures proving the failure in following the requirements of the above-mentioned legislation.

In light of the above, it is forbidden to all employees and co-operators to:

- receive any commission, percentage or benefits of any possible kind;
- Start and maintaining any business relationship with **Clients** that could cause conflict of interests with their task and function covered on behalf of **TASNEEF**.
- Receive gifts, travel tickets or any other kind of benefits different from monetary compensation, that could exceed the ordinary business politeness.

Violation of the above-mentioned principles allows **TASNEEF** to early terminate the contract and to be entitled to claim compensation for losses if any.



EXPLANATORY NOTE TO PART E

1. Reference edition

The reference edition for Part E is the Tasneef Rules 2000 edition, which is effective from 1 June 2000.

2. Amendments after the reference edition

2.1 Tasneef Rules 2000 has been completely rewritten and reorganised.

2.2 Except in particular cases, the Rules are updated and published annually.

3. Effective date of the requirements

3.1 All requirements in which new or amended provisions with respect to those contained in the reference edition have been introduced are followed by a date shown in brackets.

The date shown in brackets is the effective date of entry into force of the requirements as amended by the last updating. The effective date of all those requirements not followed by any date shown in brackets is that of the reference edition.

3.2 Item 6 below provides a summary of the technical changes from the preceding edition. In general, this list does not include those items to which only editorial changes have been made not affecting the effective date of the requirements contained therein.

4. Rule Variations and Corrigenda

Until the next edition of the Rules is published, Rule Variations and/or corrigenda, as necessary, will be published on the Tasneef web site (www.Tasneef.ae). Except in particular cases, paper copies of Rule Variations or corrigenda are not issued.

5. Rule subdivision and cross-references

5.1 Rule subdivision

The Rules are subdivided into six parts, from A to F.

Part A: Classification and Surveys

Part B: Hull and Stability

Part C: Machinery, Systems and Fire Protection

Part D: Materials and Welding

Part E: Service Notations

Part F: Additional Class Notations

Each Part consists of:

- Chapters
- Sections and possible Appendices
- Articles
- Sub-articles
- Requirements

Figures (abbr. Fig) and Tables (abbr. Tab) are numbered in ascending order within each Section or Appendix.

5.2 Cross-references

Examples: Pt A, Ch 1, Sec 1, [3.2.1] or Pt A, Ch 1, App 1, [3.2.1]

- Pt A means Part A

The part is indicated when it is different from the part in which the cross-reference appears. Otherwise, it is not indicated.

- Ch 1 means Chapter 1

The Chapter is indicated when it is different from the chapter in which the cross-reference appears. Otherwise, it is not indicated.

- Sec 1 means Section 1 (or App 1 means Appendix 1)

The Section (or Appendix) is indicated when it is different from the Section (or Appendix) in which the cross-reference appears. Otherwise, it is not indicated.

- [3.2.1] refers to requirement 1, within sub-article 2 of article 3.

Cross-references to an entire Part or Chapter are not abbreviated as indicated in the following examples:

- Part A for a cross-reference to Part A
- Part A, Chapter 1 for a cross-reference to Chapter 1 of Part A.

6. Summary of amendments introduced in the edition effective from 1 July 2024

Foreword

This edition of Part E contains amendments whose effective date is **1 July 2024**.

The date of entry into force of each new or amended item is shown in brackets after the number of the item concerned.

Part E Service Notations

Chapters 1 2 3 4 5 6 7 8 9 10 11 12 13 14 15 16 17 18 19 20 21 22 23 24 25 26 27 28 29 30 31 32 33

Chapter 1	RO-RO CARGO SHIPS
Chapter 2	CONTAINER SHIPS
Chapter 3	LIVESTOCK CARRIERS
Chapter 4	BULK CARRIERS
Chapter 5	ORE CARRIERS
Chapter 6	COMBINATION CARRIERS
Chapter 7	OIL TANKERS AND FLS TANKERS
Chapter 8	CHEMICAL TANKERS
Chapter 9	LIQUEFIED GAS CARRIERS
Chapter 10	TANKERS
Chapter 11	PASSENGER SHIPS
Chapter 12	RO-RO PASSENGER SHIPS
Chapter 13	SHIPS FOR DREDGING ACTIVITY
Chapter 14	TUGS
Chapter 15	SUPPLY VESSELS
Chapter 16	FIRE FIGHTING VESSELS
Chapter 17	OIL RECOVERY SHIPS
Chapter 18	CABLE-LAYING UNITS
Chapter 19	NON-PROPELLED UNITS
Chapter 20	FISHING VESSELS
Chapter 21	RESEARCH SHIPS
Chapter 22	PIPE LAYING UNITS
Chapter 23	CEMENT CARRIERS
Chapter 24	COMPRESSED NATURAL GAS (CNG) CARRIERS
Chapter 25	OIL CARRIERS - ASSISTED PROPULSION
Chapter 26	PALM OIL CARRIERS - ASSISTED PROPULSION
Chapter 27	UNITS FOR TRANSHIPMENT OF DRY CARGO IN BULK
Chapter 28	CHEMICAL RECOVERY SHIPS
Chapter 29	WELL STIMULATION SHIPS
Chapter 30	MARINE MOBILE DESALINATION UNIT
Chapter 31	CHEMICAL TANKER - ASSISTED PROPULSION
Chapter 32	OFFSHORE SUPPORT VESSEL (OSV)
Chapter 33	WIND TURBINE INSTALLATION VESSEL

CHAPTER 16

FIRE FIGHTING VESSELS

Section 1 General

1	General	45
1.1	Application	
1.2	Summary table	

Section 2 Hull and Stability

1	Stability	46
1.1	Intact stability	
2	Structure design principles	46
2.1	Hull structure	
2.2	Water and foam monitors	
3	Other structures	47
3.1	Arrangement for hull and superstructure openings	

Section 3 Machinery and Systems

1	General	48
1.1	Application	
1.2	Documents to be submitted	
2	Design of machinery systems	48
2.1	Manoeuvrability	
2.2	Fuel oil capacity	
2.3	Scuppers	
3	General requirements for fire-fighting systems	49
3.1	General	
3.2	Independence of pumping and piping systems	
3.3	Design and construction of piping systems	
3.4	Monitors	
3.5	Monitor control	
4	Water fire-fighting system	50
4.1	Characteristics	
4.2	Monitors	
4.3	Piping	
5	Fixed foam fire-extinguishing system	51
5.1	General	
5.2	Characteristics	
5.3	Arrangement	

6	Portable fire-fighting equipment	51
6.1	Portable high expansion foam generator	
6.2	Hydrants and fire hoses	
7	Firemen's outfits	52
7.1	Number and characteristics	
7.2	Compressed air system for breathing apparatuses	
8	Testing	52
8.1	General	
8.2	Workshop tests	
8.3	On board tests	

Section 4 Fire Protection and Extinction

1	General	53
1.1	Application	
1.2	Documents to be submitted	
2	Fire protection of exposed surfaces	53
2.1	Structural fire protection	
2.2	Deadlights and shutters	
3	Self-protection water-spraying system	53
3.1	General	
3.2	Capacity	
3.3	Arrangement	
3.4	Pumps	
3.5	Piping system and spray nozzles	

CHAPTER 17

OIL RECOVERY SHIPS

Section 1 General

1	General	57
1.1	Application	
1.2	Summary table	

Section 2 Hull and Stability

1	General	58
1.1	Oil removal	
1.2	Definitions	
2	General arrangement design	58
2.1	Segregation of spaces intended for retention of oil	
2.2	Dangerous spaces	
2.3	Access to safe spaces	
3	Stability	58
3.1	Intact stability	
4	Design loads	58
4.1	Oil removal and spraying	
5	Hull scantlings	58
5.1	Accumulation tanks	
6	Other structures	58
6.1	Hull and superstructure openings	
7	Construction and testing	59
7.1	Testing	

Section 3 Machinery and Systems

1	General	60
1.1	Application	
1.2	Documents to be submitted	
1.3	Definitions	
2	Machinery installations and piping systems not intended for recovered oil	60
2.1	Bilge system	
2.2	Sea water cooling system	
2.3	Water fire-extinguishing system	
2.4	Exhaust gas systems	
2.5	Additional requirements for machinery installations in gas-dangerous areas	
3	Pumping system, piping system and pump rooms intended for recovered oil	60
3.1	Design of pumping and piping systems	
3.2	Arrangement of piping systems and pump rooms	
4	Settling and accumulation tanks	61
4.1	General	
4.2	Vent pipes	
4.3	Level gauging and overfilling control	
4.4	Heating systems	

Section 4 Electrical Installations

1	General	63
1.1	Application	
1.2	Documentation to be submitted	
2	Design requirements	63
2.1	System of supply	
2.2	Earth detection	
3	Hazardous locations and types of equipment	63
3.1	Electrical equipment permitted in hazardous areas	
3.2	Hazardous area classification	

Section 5 Fire Protection, Detection and Extinction

1	General	65
1.1	Application	
1.2	Documents to be submitted	
1.3	Definitions	
2	Ventilation systems	65
2.1	General	
2.2	Ventilation of recovered oil pump rooms	
2.3	Ventilation of enclosed normally entered dangerous spaces other than cargo pump rooms	
2.4	Ventilation of enclosed safe spaces adjacent to dangerous areas	
3	Fire protection and fire fighting	66
3.1	General	
3.2	Oil flashpoint and gas measurement systems	
3.3	Structural fire protection	
3.4	Fire fighting	

CHAPTER 18

CABLE-LAYING UNITS

Section 1 General

1	General	71
1.1	Application	
1.2	Summary table	

Section 2 Hull and Stability

1	General	72
1.1	Application	
2	Stability	72
2.1	Intact stability	
3	Hull scantlings	72
3.1	Cable tanks	
3.2	Connection of the machinery and equipment with the hull structure	
4	Other structures	72
4.1	Fore part	
5	Hull outfitting	72
5.1	Equipment	

Section 3 Machinery and Systems

1	General	73
1.1	Propulsion and manoeuvrability	
1.2	Documents to be submitted	
2	Arrangements for cable laying, hauling and repair	73
2.1	Typical machinery and equipment of cable laying units	
2.2	Design of cable handling machinery and equipment	
2.3	Safety	
2.4	Testing of cable handling machinery and equipment	
3	On board trials	74
3.1	Ship trials	
3.2	Equipment trials	

CHAPTER 19

NON-PROPELLED UNITS

Section 1 General

1	General	77
1.1	Application	
1.2	Summary table	

Section 2 Hull and Stability

1	General	78
1.1	Application	
2	Stability	78
2.1	Intact stability for ships with service notation "barge", "pontoon" or "pontoon-crane"	
2.2	Additional intact stability criteria for ships with service notation "pontoon - crane"	
2.3	Additional intact stability criteria for ships with service notation "barge-oil"	
2.4	Additional intact stability criteria for units with service notation "barge - accommodation"	
2.5	Additional intact stability criteria for units with service notation "barge - liquefied gas" and "barge - LNG bunker"	
2.6	Additional intact stability criteria for units with service notation "barge - chemical"	
3	Structure design principles	83
3.1	Hull structure	
3.2	Lifting appliances	
4	Hull girder strength	83
4.1	Yielding check	
5	Hull scantlings	84
5.1	General	
5.2	Hull scantlings of non-propelled units with the service notation "pontoon" fitted with arrangements and systems for launching operations	
5.3	Hull scantlings of non-propelled units with service notation "pontoon - crane"	
6	Other structures	85
6.1	Reinforcement of the flat bottom forward area of ships with one of the service notations "pontoon" and "pontoon - crane"	
7	Hull outfitting	86
7.1	Equipment	
8	Additional arrangement requirements for ships with service notation "Barge-oil"	87
8.1	Application	
8.2	Cargo segregation	
8.3	Size and arrangement of cargo tanks and slop tanks	

	8.4	Access arrangement	
9		Mooring systems for units with the service notation "barge - accommodation"	89
	9.1	Application	
10		Additional requirements for ships with service notation "Barge-liquefied gas"	89
	10.1	Accommodation, service and machinery spaces and control stations	
	10.2	Access arrangement	
	10.3	Cargo containment	
	10.4	Materials for construction	
11		Additional requirements for ships with service notation "Barge-LNG bunker"	91
	11.1	Mooring and fendering	
	11.2	Access arrangement	
	11.3	Cargo containment	
	11.4	Materials for construction	
12		Additional requirements for ships with service notation "Barge-chemical"	91
	12.1	Accommodation, service and machinery spaces and control stations	
	12.2	Cargo tank arrangement	
	12.3	Access arrangement	
	12.4	Coamings	
	12.5	Cargo containment	
	12.6	Materials for construction	
	12.7	Minimum distance of cargo tanks from shell	

Section 3 Machinery Systems

1		General	94
	1.1	Application	
	1.2	Documents to be submitted	
	1.3	Exemptions	
2		Bilge system	94
	2.1	Bilge system in ships having no source of electrical power	
	2.2	Bilge system in ships having a source of electrical power	
3		Additional requirements for units with service notation "barge-accommodation"	95
	3.1	Bilge system	
	3.2	Ballast system	
	3.3	Special requirements for starting arrangement of emergency generating sets	

Section 4 Additional Requirements for Machinery and Cargo Systems of Barge-Oil

1		General	97
	1.1	Application	
	1.2	Documents to be submitted	
	1.3	Exemptions	

2	Additional requirements for ships with service notation "barge-oil"	97
2.1	Piping systems other than cargo piping system	
2.2	Cargo pumping system	
2.3	Cargo tanks and fittings	
2.4	Prevention of pollution by cargo oil	
3	Additional requirements for barge-oil intended to carry products having flashpoint > 60°C	106
3.1	Piping systems other than cargo piping system	
3.2	Cargo pumping system	
3.3	Cargo piping	
3.4	Cargo tanks and fittings	
3.5	Prevention of pollution by cargo oil	
4	Certification, inspection and testing	107
4.1		

Section 5 Additional Requirements for Machinery and Cargo Systems of Barge-Liquefied Gas

1	General	108
1.1	Application	
1.2	Documents to be submitted	
1.3	Exemptions	
2	Cargo pump rooms and cargo compressor rooms	109
2.1	Equipment in cargo pump rooms and cargo compressor rooms	
3	Bilge, ballast and fuel oil arrangements	109
3.1	Drainage arrangement	
3.2	Additional requirements relative to the bilge system	
4	Bow or stern loading and unloading arrangements	109
4.1	Locations of stopping devices for cargo pumps and compressors	
5	Process pressure vessels and liquid, vapour and pressure piping systems	109
5.1	General	
5.2	Cargo and process piping	
5.3	Tests of piping components and pumps prior to installation on board	
5.4	Cargo system valving requirements	
5.5	Cargo transfer methods	
5.6	Bonding	
5.7	Integrated cargo and ballast system	
6	Cargo tank venting system	113
6.1	Pressure relief systems	
6.2	Additional pressure relieving system for liquid level control	
7	Environmental control	115
7.1	Inerting	
7.2	Inert gas production on board	
8	Mechanical ventilation in the cargo area	116
8.1	Spaces required to be entered during normal cargo handling operations	

8.2	Spaces not normally entered	
9	Instrumentation (Gauging, Gas detection)	116
9.1	General	
9.2	Level indicators for cargo tanks	
9.3	Overflow control	
9.4	Pressure gauges	
9.5	Temperature indicating devices	
9.6	Gas detection requirements	
10	Special requirements	118
10.1	Materials for construction	
10.2	Inhibition	
10.3	Chlorine	
11	Personnel protection requirements for individual products	119
11.1	Showers and eyes wash	
12	Summary of minimum requirements	119
12.1	Additional information on products	

Section 6 Additional Requirements for Machinery and Cargo Systems of Barge-LNG Bunker

1	General	121
1.1	Application	
1.2	Scope	
2	Definitions	121
2.1	Bunker emergency shut-down system (ESD)	
2.2	Bunkering connections	
2.3	Custody Transfer Measuring system	
2.4	Emergency release coupling (ERC) or breakaway coupling (BRC)	
2.5	ESD link system or Ship-ship link (SSL)	
2.6	LNG bunkering station	
2.7	LNG transfer system	
2.8	MID	
2.9	OIML R117-1	
2.10	Pendant	
2.11	Quick connect and disconnect coupling (QCDC)	
2.12	Safety zone	
2.13	Transfer arm	
3	Document to be submitted	122
3.1	General	
4	General design requirements	123
4.1	Risk Assessment	
4.2	Hazardous area	
4.3	Materials	
4.4	Arrangement of bunkering system	
4.5	Mooring and fendering	
5	Hoses and pumps	125
5.1	Hose design requirements	

5.2	Type approval, testing and certification of LNG bunkering hoses	
5.3	Testing of Hoses at workshop	
5.4	Hoses documentation	
5.5	Marking of products	
5.6	Transfer pumps	
6	Quick connect disconnect coupler (QCDC)	126
6.1	Type approval, testing and certification of QCDC	
6.2	Type testing	
6.3	Workshop testing	
7	Emergency release coupling (ERC)	127
7.1	Type approval, testing and certification of QCDC	
7.2	Type approval, testing and certification of ERC	
7.3	Type testing	
7.4	Workshop testing	
8	Electrical insulation flanges	127
8.1	General	
9	Hose Supports and transfer arms	127
9.1	General	
9.2	Transfer arms	
10	Inert Gas System	128
10.1		
11	Gas detection	128
11.1	Gas detection in enclosed spaces	
11.2	Gas detection in open spaces	
12	Control and safety systems	128
12.1	General	
12.2	Emergency shut-down systems (ESD)	
12.3	Alarms and safety actions	
12.4	Communication systems	
13	Testing of the LNG transfer system at workshop	130
13.1	Pressure test	
13.2	Inspection of welds	
14	Testing and trials of the LNG transfer system at yard	130
14.1		
14.2	Piping leak test	
14.3	Inerting	
15	Implementation survey	131
15.1		
16	Additional features	131
16.1	IG-Bunker (Inert Gas Bunker)	
16.2	BT (Bunker Trust)	
16.3	VCS-Bunker (Vapour Control System Bunker)	

Section 7 Additional Requirements for Machinery and Cargo Systems of Barge-Chemical

1	General	132
	1.1 Application	
	1.2 Documents to be submitted	
	1.3 Exemptions	
2	Cargo pump rooms	133
	2.1 Machinery driven by shafting passing through pump room bulkheads	
3	Fuel tanks in cargo area	133
	3.1 Definition	
	3.2 Location of fuel tanks in cargo area	
4	Bilge and ballast arrangements	133
	4.1 Ballast segregation	
	4.2 Ballast filling arrangement	
	4.3 Bilge	
5	Piping systems other than cargo piping system	134
	5.1 General	
	5.2 Bilge system	
	5.3 Ballast system	
	5.4 Scupper pipes	
	5.5 Cargo temperature control	
6	Cargo pumping and piping systems	136
	6.1 General	
	6.2 Cargo pumping system	
	6.3 Cargo transfer	
7	Cargo tanks and fittings	140
	7.1 Application	
	7.2 Cargo tank venting	
	7.3 Cargo tank gas freeing	
	7.4 Environmental control	
	7.5 Instrumentation	
	7.6 Tank washing systems	
8	Certification, inspection and testing of piping systems	144
	8.1 Application	
	8.2 Workshop tests	
	8.3 Shipboard tests	
9	Special Requirements	145
	9.1 Ammonium nitrate solution (93% or less)	
	9.2 Hydrogen peroxide solutions	
	9.3 Propylene oxide and mixtures of ethylene oxide/propylene oxide with an ethylene oxide content of not more than 30% by mass	
	9.4 Sulphur (molten)	
	9.5 Acids	
	9.6 Toxic products	
	9.7 Cargoes protected by additives	
	9.8 Cargoes with a vapour pressure greater than 0,1013 MPa (1,013 bar) absolute at 37,8°C	
	9.9 Special cargo pump room requirements	

- 9.10 Overflow control -
Independence of systems

Section 8 Electrical Installations

1	Electrical installations for units with service notation "barge-oil"	148
<hr/>		
	1.1 Application	
	1.2 Exemptions	
	1.3 Documentation to be submitted	
	1.4 System of supply	
	1.5 Electrical equipment	
	1.6 Earth detection	
	1.7 Precautions against inlet of gases or vapours	
	1.8 Electrical equipment permitted in hazardous areas	
	1.9 Hazardous area classification	
2	Electrical installations for units with service notation "barge-accommodation"	150
<hr/>		
	2.1 Application	
	2.2 Documentation to be submitted	
	2.3 Electrical distribution and protection	
	2.4 Control station	
	2.5 Main source of electrical power	
	2.6 Emergency source of electrical power and emergency installations	
	2.7 Escape lighting system	
	2.8 General emergency alarm and public address systems	
	2.9 Installation	
	2.10 Type approved components	
3	Electrical installations for units with service notation "barge-chemical"	153
<hr/>		
	3.1 Application	
	3.2 Exemptions	
	3.3 Documentation to be submitted	
	3.4 System of supply	
	3.5 Electrical equipment	
	3.6 Earth detection	
	3.7 Precautions against inlet of gases or vapours	
	3.8 Electrical equipment permitted in hazardous areas	
	3.9 Hazardous area classification	
4	Electrical installations for units with service notation "barge-liquefied gas" and units with service notation "barge-LNG Bunker"	155
<hr/>		
	4.1 Application	
	4.2 Exemptions	
	4.3 Documentation to be submitted	
	4.4 System of supply	
	4.5 Earth detection	
	4.6 Precautions against inlet of gases or vapours	
	4.7 Electrical equipment permitted in hazardous areas	
	4.8 Hazardous area classification	
	4.9 Submerged cargo pumps	
	4.10 Product classification	

CHAPTER 20

FISHING VESSELS

Section 1 General

1	General	161
1.1	Application	
1.2	Summary table	

Section 2 Ship Arrangement

1	General arrangement design	162
1.1	Subdivision arrangement	
1.2	Cofferdams	
2	Bow height	163
2.1	Vessels of not less than 24 m in length	
2.2	Vessels of length less than 24 m	

Section 3 Hull and Stability

1	Stability	164
1.1	Intact stability	
2	Hull scantlings of ships equal to or greater than 65 m in length	165
2.1	Plating	
2.2	Aft ramp	
3	Hull scantlings of ships less than 65 m in length	165
3.1	General	
3.2	Longitudinally framed single bottom	
3.3	Transversely framed single bottom	
3.4	Bilge	
3.5	Double bottom	
3.6	Open floors in transversely framed double bottom	
3.7	Side	
3.8	Decks	
3.9	Tank bulkheads	
3.10	Watertight bulkheads	
3.11	Non-tight bulkheads	
3.12	Connection of the fore part with the structures located aft of the collision bulkhead	
3.13	Fore peak longitudinally framed bottom	
3.14	Fore peak transversely framed bottom	
3.15	Fore peak longitudinally framed side	
3.16	Fore peak transversely framed side	
3.17	Fore peak platforms	
3.18	Bulbous bow	
3.19	Reinforcement of the flat bottom forward area	
3.20	Stems	

3.21	Sternframes	
3.22	Machinery casings	
3.23	Superstructures and deckhouses	
3.24	Hatch covers	
3.25	Aft ramp	
3.26	Arrangement for hull and superstructure openings	
4	Scantlings of masts and fishing devices (e.g. gantries and trawl gallows)	180
4.1	Design loads	
4.2	Strength check	
5	Hull outfitting	180
5.1	Rudder stock scantlings	
5.2	Propeller shaft brackets	
5.3	Equipment	
6	Protection of hull metallic structures	181
6.1	Protection of deck by wood sheathing	
6.2	Protection of cargo sides by battens	
6.3	Deck composition	

Section 4 Machinery

1	General	183
1.1	Application	
1.2	Documents to be submitted	
2	Bilge system	183
2.1	General	
2.2	Design of the bilge system	
2.3	Bilge pumps	
2.4	Size of bilge pipes	
2.5	Bilge piping arrangement	
3	Scuppers and sanitary discharges	185
3.1	General	
3.2	Discharges through manned machinery spaces	
3.3	Materials	
4	Air pipes and sounding devices	185
4.1	Air pipes	
4.2	Sounding devices	
5	Refrigeration systems for the preservation of the catch	186
5.1	General	
5.2	Design of refrigeration systems	
5.3	Arrangement of the refrigerating machinery spaces and refrigerating rooms	
5.4	Breathing apparatus	

Section 5 Electrical Installations

1	General	187
----------	----------------	------------

	1.1 Application	
2	Documentation to be submitted	187
	2.1	
3	Type approved components	187
	3.1	
4	General requirements for system design, location and installation	187
	4.1 Design and construction	
	4.2 Main source of electrical power	
	4.3 Emergency source of electrical power	
	4.4 Precaution against shock, fire and other hazards of electrical origin	
	4.5 Engineers' alarm	
5	Lightning protection	190
	5.1 General	

CHAPTER 21

RESEARCH SHIPS

Section 1 General

1	Application	193
1.1		
2	Specific requirements	193
2.1		

CHAPTER 22

PIPE LAYING UNITS

Section 1 General

1	General	197
1.1	Application	
1.2	Summary table	

Section 2 Hull and Stability

1	General	198
1.1	Application	
1.2	Documents to be submitted	
2	Foundation structures, supporting structures and fastening	198
2.1		
3	Connecting structures of the stinger to the hull	198
3.1		

Section 3 Machinery and Systems

1	General	199
1.1	Application	
1.2	Documents to be submitted	
2	Pipe laying equipment	199
2.1		
3	Anchoring equipment	199
3.1		
4	Dynamic positioning equipment during pipe laying	199
4.1		
5	Testing of pipe laying, anchoring and positioning equipment	199
5.1	Testing of materials	
5.2	Hydraulic tests	
5.3	Tests of mechanical components	
5.4	Tests on electrical components	
6	Equipment trials on board	199
6.1		

CHAPTER 23

CEMENT CARRIERS

Section 1 General

1	General	203
1.1	Application	
1.2	Summary table	

Section 2 Ship Arrangement, Hull and Stability

1	General	204
1.1	Documents to be submitted	
2	Ship arrangement	204
2.1	General	
3	Corrosion additions	204
3.1	General	
4	Stability	204
4.1	Intact stability	
5	Design loads	204
5.1	Internal pressures due to cement cargo	
5.2	Loading conditions to be considered in structural analyses of primary supporting members based on three dimensional models	

Section 3 Machinery and Systems

1	General	206
1.1	Documents to be submitted	
2	Cement handling system	206
2.1	General	
3	Testing of cement handling equipment	206
3.1	Workshop testing	
3.2	On board testing	

CHAPTER 24

COMPRESSED NATURAL GAS (CNG) CARRIERS

Section 1 General

1	General	211
1.1	Application	
1.2	Fundamental safety requirements	
2	Definitions	211
2.1	Terms	
3	Additional requirements	212
3.1	Emergency towing arrangement	
3.2	Steering gear	
4	Documentation to be submitted	212
4.1		

Section 2 Ship Arrangement

1	Segregation of the cargo area	215
1.1	Segregation of hold spaces	
1.2	Location of cargo holds	
2	Accommodation, service and machinery spaces and control stations	215
2.1	General	

Section 3 Ship Survival Capabilities

1	Freeboard and intact stability	216
1.1	Intact stability	
1.2	Damaged stability	
2	Collisions and groundings	216
2.1	General	
3	Pipes, ducts and trunks in damaged zones	216
3.1	Strength of internal structures	

Section 4 Cargo Containment

1	General	217
1.1	Application	

Section 5 Process Pressure Vessels and Piping Systems

1	Gas-fuelled ship	218
1.1	Application	
2	Process pressure vessels	218
2.1	General	
3	Cargo and process piping	218
3.1	General	
3.2	Scantlings based on internal pressure	
3.3	Permissible stress	
3.4	Aluminised pipes	
4	Tests of piping components and pumps prior to installation on board	220
4.1	Valves	
5	Liquid transfer pumps	220
5.1	General	
5.2	Prototype Testing	
5.3	Unit Production Testing	
6	Cargo valves	220
6.1	General	
7	Emergency shutdown	221
7.1	Clarification on location of fusible elements	
8	Bonding	221
8.1	Static electricity	

Section 6 Materials for Construction

1	General	222
1.1		

Section 7 Overpressure Protection for Cargo Containment and Piping System

1	General	223
1.1		
2	Cargo Tanks and piping	223
2.1	General	
3	Information to the Master	223
3.1	Requirements	

Section 8 Environmental Control

1	Precautions against fire	224
---	--------------------------	-----

1.1		
2	Environmental Control within Cargo Tanks and Cargo Piping Systems	224
2.1	General	
3	Environmental Control within the Hold Spaces for Cargo Tanks	224
3.1	General	
4	Inerting	224
4.1		
5	Inert gas production on board	224
5.1	Exemptions	

Section 9 Electrical Installations

1	General	225
1.1	Application	
1.2	Documentation to be submitted	
1.3	System of supply	
1.4	Earth detection	
1.5	Precautions against inlet of gases or vapours	
1.6	Electrical equipment permitted in hazardous areas	
2	Hazardous locations	226
2.1	Hazardous area classification	
3	Product classification	226
3.1	Temperature class and explosion group	

Section 10 Fire Protection and Fire Extinction

1	Application	228
1.1	General	
2	Additional criteria	228
2.1	Structural fire protection	
3	Means of escape	228
3.1		
4	Fire Extinction	228
4.1		

Section 11 Mechanical Ventilation in the Cargo Area

1	General	230
1.1	Safety	
1.2	Shutdown philosophy	

2	Spaces required to be entered during normal cargo handling operations	230
	2.1 Location of discharges from dangerous spaces	
	2.2 Recirculation prevention	
	2.3 Non-sparking fans	
3	Spaces not normally entered	231
	3.1 General requirements	

Section 12 Instrumentation (Gauging, Gas Detection)

1	General	232
	1.1	
	1.2 Cargo tank instrumentation	
	1.3 Drainage	
	1.4 Indicator location	
2	Gas detection requirements	232
	2.1	
	2.2 Gas Measurements	
	2.3 Position of sampling heads	
3	Protected spaces	233
	3.1	
4	Portable gas detectors	233
	4.1	

Section 13 Use of Cargo as Fuel

1	Application	234
	1.1 General	
	1.2 Testing	

Section 14 Special Requirements

1	Materials for construction	235
	1.1	
2	Independent tanks	235
	2.1	
3	Deck cargo piping	235
	3.1	
4	Exclusion of air from vapor spaces	235
	4.1	
5	Moisture control	235
	5.1	

6	Permanently installed toxic gas detectors	235
	6.1	
7	Flame screens on vent outlets	235
	7.1	

Section 15 Additional Informations on Products

1	General	236
	1.1	

CHAPTER 25

OIL CARRIERS - ASSISTED PROPULSION

Section 1 General

1	General	239
1.1	Application	
1.2	Summary tables	
1.3	Definitions	

Section 2 Ship Arrangement

1	General	241
1.1	Application	
2	General arrangement design	241
2.1	General	
2.2	Double bottom tanks or compartments	
2.3	Navigation position	
3	Size and arrangement of cargo tanks and slop tanks	243
3.1	Cargo tanks	
3.2	Slop tanks	
4	Access arrangement	243
4.1	General	
4.2	Access to pipe tunnel and opening arrangement	
4.3	Access to compartments in the cargo area	

Section 3 Stability

1	Stability	246
1.1	Application	
1.2	Intact stability	

Section 4 Machinery and Cargo Systems

1	General	247
1.1	Application	
1.2	Documents to be submitted	
2	Piping systems other than cargo piping system	247
2.1	General	
2.2	Bilge system	
2.3	Ballast system	
2.4	Air and sounding pipes of spaces other than cargo tanks	
2.5	Scupper pipes	
2.6	Heating systems intended for cargo	

3	Cargo pumping systems	250
3.1	General	
3.2	Cargo pumping system	
3.3	Cargo piping design	
3.4	Cargo piping arrangement and installation	
3.5	Integrated cargo and ballast systems design	
4	Cargo tanks and fittings	254
4.1	Application	
4.2	Cargo tank venting	
4.3	Cargo tank purging and/or gas-freeing	
4.4	Cargo tank level gauging systems	
4.5	Protection against tank overload	
4.6	Tank washing systems	
5	Prevention of pollution by cargo oil	257
5.1	General	
5.2	Retention of oil on board	
5.3	Pumping, piping and discharge arrangements	
6	Certification, inspection and testing	258
6.1	Application	
6.2	Workshop tests	
6.3	Shipboard tests	

Section 5 Machinery and Cargo Systems for Oil Carrier, Flashpoint > 60°C

1	General	260
1.1	Application	
1.2	Documents to be submitted	
2	Piping systems other than cargo piping system	260
2.1	General	
2.2	Bilge system	
2.3	Ballast system	
2.4	Scupper pipes	
2.5	Heating systems intended for cargo	
3	Cargo pumping and piping systems	261
3.1	General	
3.2	Cargo pumping system	
3.3	Cargo piping design	
3.4	Cargo piping arrangement and installation	
3.5	Integrated cargo and ballast systems design	
4	Cargo tanks and fittings	264
4.1	Application	
4.2	Cargo tank venting	
4.3	Protection against tank overload	
4.4	Tank washing systems	
5	Prevention of pollution by cargo oil	264
5.1	General	
5.2	Retention of oil on board	
5.3	Pumping, piping and discharge arrangements	

6	Certification, inspection and testing	266
----------	--	------------

- 6.1 Application
- 6.2 Workshop tests
- 6.3 Shipboard tests

Section 6 Electrical Installations

1	General	268
----------	----------------	------------

- 1.1 Application
- 1.2 Documentation to be submitted
- 1.3 System of supply
- 1.4 Electrical equipment
- 1.5 Earth detection
- 1.6 Precautions against inlet of gases or vapours
- 1.7 Electrical equipment permitted in hazardous areas

2	Special requirements for oil carriers carrying flammable liquids having a flash point not exceeding 60°C	269
----------	---	------------

- 2.1 Hazardous area classification

3	Special requirements for oil carrier carrying flammable liquids having a flash point exceeding 60°C	269
----------	--	------------

- 3.1 Hazardous area classification
- 3.2 Cargoes heated to a temperature above their flash point and cargoes heated to a temperature within 15°C of their flash point

CHAPTER 26

PALM OIL CARRIERS - ASSISTED PROPULSION

Section 1 General

1	General	273
1.1	Application	
1.2	Summary tables	
1.3	Definitions	

Section 2 Ship Arrangement

1	General	275
1.1	Application	
2	General arrangement design	275
2.1	General	
2.2	Double bottom tanks or compartments	
3	Size and arrangement of cargo tanks and slop tanks	276
3.1	Cargo tanks	
4	Access arrangement	276
4.1	General	
4.2	Access to pipe tunnel and opening arrangement	
4.3	Access to compartments in the cargo area	

Section 3 Stability

1	Stability	278
1.1	Intact stability	

Section 4 Machinery and Cargo Systems

1	General	279
1.1	Application	
1.2	Documents to be submitted	
2	Piping systems other than cargo piping system	279
2.1	General	
2.2	Bilge system	
2.3	Ballast system	
2.4	Scupper pipes	
2.5	Heating systems intended for cargo	
3	Cargo pumping and piping systems	281
3.1	General	
3.2	Cargo pumping system	

3.3	Cargo piping design	
3.4	Cargo piping arrangement and installation	
3.5	Integrated cargo and ballast systems design	
4	Cargo tanks and fittings	282
4.1	Application	
4.2	Cargo tank venting	
4.3	Protection against tank overload	
5	Prevention of pollution by palm oil	283
5.1	General	
6	Certification, inspection and testing	283
6.1	Application	
6.2	Workshop tests	
6.3	Shipboard tests	

Section 5 Electrical Installations

1	General	285
1.1	Application	
1.2	Documentation to be submitted	
1.3	System of supply	
1.4	Electrical equipment	
1.5	Earth detection	
1.6	Precautions against inlet of gases or vapours	
1.7	Electrical equipment permitted in hazardous areas	
1.8	Hazardous area classification	

CHAPTER 27

UNITS FOR TRANSHIPMENT OF DRY CARGO IN BULK

Section 1 General

1	General	289
	1.1 Application	
	1.2 Summary table	

Section 2 Unit Arrangement

1	General	290
	1.1 Application	
	1.2 Documents to be submitted	
2	Cargo handling arrangements	290
	2.1 General	
3	Ship-to-Unit Mooring arrangements	290
	3.1 General	
	3.2 Mooring analysis	
4	Access on board arrangement	291
	4.1	

Section 3 Hull and Stability

1	Application	292
	1.1	
2	Stability	292
	2.1 Intact stability under navigating conditions	
	2.2 Intact stability under operation	
	2.3 Intact stability for units carrying grain, cement and similar, IMSBC-A cargoes, nitrates, non-cohesive or other special cargo	
3	Design loads	293
	3.1 Unit motions and accelerations	
	3.2 Additional requirements on local loads for units with the additional service feature heavycargo	
	3.3 Characteristics of bulk cargoes carried in holds	
4	Hull scantlings	293
	4.1 General	

CHAPTER 28

CHEMICAL RECOVERY SHIPS

Section 1 General

1	General	297
1.1	Application	
1.2	Summary table	

Section 2 Hull and Stability

1	General	298
1.1		
2	Documentation to be submitted	298
2.1		
3	Operations in hazardous atmosphere	298
3.1	Citadel	
3.2	Windows	

Section 3 Machinery and Systems

1	Machinery and systems installations	299
1.1		
2	Documentation to be submitted	299
2.1		
3	Operations in hazardous atmosphere	299
3.1	Citadel ventilation system	
3.2	Gas detection and alarm	
3.3	Machinery intake air system	
3.4	Machinery exhaust gas system	
3.5	Operations and Equipment Manual	

Section 4 Electrical Installations

1	General	301
1.1	Application	
2	Documentation to be submitted	301
2.1		

Section 5 Fire Protection, Detection and Extinction

1	General	302
1.1	Application	
2	Operations in hazardous atmosphere	302
2.1	General	

CHAPTER 29

WELL STIMULATION SHIPS

Section 1 General

1	General	305
1.1	Application	
1.2	Summary table	

Section 2 Hull and Stability

1	General	306
1.1	Tanks for storage of stimulating liquids	
1.2	Tanks material	
1.3	Documents to be submitted	
1.4	Operational Manual	
2	General arrangement design	306
2.1	Tank location and segregation of spaces	
2.2	Protection from liquid spill	
2.3	Hazardous area	
2.4	Accesses, Air intakes, windows and other openings to accommodation spaces	
2.5	Access to spaces in the cargo area	
3	Stability	307
3.1	Intact stability	
3.2	Damage stability	
4	Hull scantlings	307
4.1	Local loads	
4.2	Movable tanks	
5	Seakeeping	307
5.1	General	
5.2	Dynamic positioning	
5.3	Station keeping with anchors and cables	

Section 3 Machinery and Systems

1	General	308
1.1	Application	
1.2	Documents to be submitted	
1.3	Calculations	
2	Machinery installations and piping systems not intended for well stimulation	309
2.1	Bilge system	
2.2	Exhaust gas systems	
2.3	Additional requirements for machinery installations in hazardous area	

3	Pumping system, piping system and pump rooms intended for well stimulation	309
3.1	Design of piping systems	
3.2	Arrangement	
3.3	Pump rooms	
3.4	Venting systems	
3.5	Mechanical ventilation of spaces in the cargo area	
3.6	Control and Monitoring	

Section 4 Electrical Installations

1	General	311
1.1	Application	
1.2	Documents to be submitted	
2	Design requirements	311
2.1	Power supply for emergency controls	
2.2	Earth detection	
3	Hazardous area	311
3.1	Hazardous area classification	
3.2	Electrical equipment permitted in hazardous area	

Section 5 Fire Protection, Detection and Extinction

1	General	312
1.1	Application	
1.2	Fire Protection, Fire Fighting system and appliances	

Section 6 Personnel Protection

1	General	313
1.1	Personnel protection	

CHAPTER 30

MARINE MOBILE DESALINATION UNIT

Section 1 General

1	General	317
1.1	Application	
1.2	Summary table	
1.3	Definitions	

Section 2 Hull and Stability

1	General arrangement design	318
1.1	Cargo Tanks	
1.2	Segregation of spaces intended for the water treatment system	
1.3	Storage and handling of chemical products used for treatment	
2	Stability	318
2.1	Intact stability	

Section 3 Machinery and Cargo Systems

1	General	320
1.1	Application	
1.2	Documents to be submitted	
2	Piping systems	320
2.1	General	
3	Desalination system: pumping and piping systems	320
3.1	Design of pumping and piping systems	
3.2	Pumping System	
4	Bilge system	320
4.1	Draining of spaces located inside the cargo area	
4.2	Drip trays in the spaces containing chemical products	
5	Air pipes	321
5.1		
6	Refrigerating installations	321
6.1		
7	Cargo tanks	321
7.1	Cargo tank cleaning systems	
7.2	Cargo tank coating	
8	Certification, inspection and testing	321
8.1	Application	
8.2	Workshop tests	
8.3	Shipboard tests	

CHAPTER 31

CHEMICAL TANKER - ASSISTED PROPULSION

Section 1 GENERAL

1	General	325
1.1	Application	

CHAPTER 32

OFFSHORE SUPPORT VESSEL (OSV)

Section 1 General

1	General	329
1.1	Application	
1.2	Summary table	
2	Offshore support vessel with additional service feature W2W	329
2.1	General	
2.2	Application	
2.3	Position keeping	
2.4	General safety criteria	
2.5	Documents to be submitted	
3	Offshore support vessel with additional service feature WIND TURBINE MAINTENANCE	330
3.1	Offshore transfer system	

Section 2 Hull and Stability

1	Offshore support vessel with additional service feature Walk-to-Work (W2W)	331
1.1	Intact stability criteria during lifting of W2W equipment	
1.2	Hull structural arrangements related to the W2W system	
1.3	Arrangement and installation of the W2W system	
2	Offshore support vessel with additional service feature WIND TURBINE MAINTENANCE	332
2.1		

Section 3 Machinery and Systems

1	Offshore support vessel with additional service feature WIND TURBINE MAINTENANCE	333
1.1	Seakeeping	

Section 4 Electrical Installations

1	Offshore support vessel with additional service feature Walk-to-Work (W2W)	334
1.1	General	
1.2	Main source and emergency source	
1.3	Distribution systems	
1.4	Installation	
1.5	Communication systems	

Appendix 1 Certification of the W2W system

1 General

335

1.1

CHAPTER 33

WIND TURBINE INSTALLATION VESSEL

Section 1 General

1	General	339
	1.1 Application	
	1.2 Summary table	
2	Wind turbine installation vessel with additional service feature W2W	339
	2.1 General	

Section 2 Hull and Stability

1	Special design principles applied to self-elevating units	340
	1.1	
2	Intact stability criteria	340
	2.1	
3	Subdivision and damage stability	340
	3.1	
4	Stability and watertight integrity	340
	4.1	
5	Freeboard	340
	5.1	

Section 3 Machinery and Systems

1	Machinery installations for self-elevating units	341
	1.1 General	
2	Cranes	341
	2.1	
3	Seakeeping	341
	3.1 General	
	3.2 Dynamic positioning	

Part E
Service Notations

Chapter 16

FIRE FIGHTING VESSELS

- SECTION 1 GENERAL**
- SECTION 2 HULL AND STABILITY**
- SECTION 3 MACHINERY AND SYSTEMS**
- SECTION 4 FIRE PROTECTION AND EXTINCTION**

SECTION 1

GENERAL

1 General

1.1 Application

1.1.1 Ships complying with the requirements of this Chapter are eligible for the assignment of the service notation **fire-fighting ship**, as defined in Pt A, Ch 1, Sec 2, [4.8.4].

1.1.2 Ships dealt with in this Chapter are to comply with the requirements stipulated in Parts A, B, C and D, as applicable, and with the requirements of this Chapter, which are specific to fire-fighting ships.

1.2 Summary table

1.2.1 Tab 1 indicates, for ready reference, the Sections of this Chapter containing specific requirements applicable to fire-fighting ships.

Table 1

Main subject	Reference
Ship arrangement	(1)
Hull and stability	Sec 2
Machinery and systems	Sec 3
Electrical installations	(1)
Automation	(1)
Fire protection and extinction	Sec 4
(1) No specific requirements for fire fighting ships are given in this Chapter.	

SECTION 2

HULL AND STABILITY

1 Stability

1.1 Intact stability

1.1.1 General

The stability of the ship for the loading conditions defined in Pt B, Ch 3, App 2, [1.2.11] is to be in compliance with the requirements in Pt B, Ch 3, Sec 2.

1.1.2 Additional criteria

All the loading conditions reported in the trim and stability booklet, with the exception of lightship, are also to be checked in order to investigate the ship's capability to support the effect of the reaction force of the water jet in the beam direction due to the monitors fitted on board.

A fire-fighting ship may be considered as having sufficient stability, according to the effect of the reaction force of the water jet in the beam direction due to the monitors fitted on board, if the heeling angle of static equilibrium θ_0 , corresponding to the first intersection between heeling and righting arms (see Fig 1), is less than 5° .

The heeling arm may be calculated as follows:

$$b_h = \frac{\sum R_i \cdot h_i + S \cdot (T/2 - e)}{9,81 \cdot \Delta} \cdot \cos\theta$$

where:

b_h : Heeling arm, in m, relevant to the reaction force of the water jet of the monitors fitted on board, and to the effect of transversal manoeuvring thrusters. The monitors are assumed to be oriented in beam direction parallel to the sea surface, so as to consider the most severe situation.

R_i : Reaction force, in kN, of the water jet of each monitor fitted on board (see Fig 2)

h_i : Vertical distance, in m, between the location of each monitor and half draught (see Fig 2)

S : Thrust, in kN, relevant to manoeuvring thruster(s), if applicable (see Fig 2)

e : Vertical distance, in m, between the manoeuvring thruster axis and keel (see Fig 2)

Δ : Displacement, in t, relevant to the loading condition under consideration

T : Draught, in m, corresponding to Δ (see Fig 2).

Figure 1 : Heeling and righting arm curves

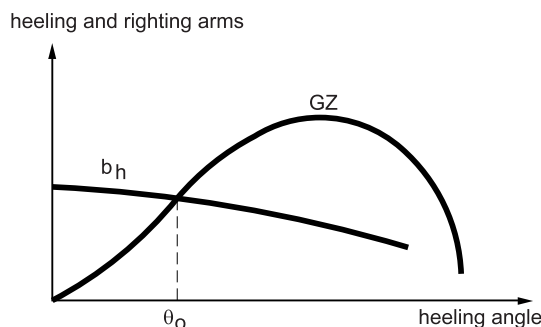
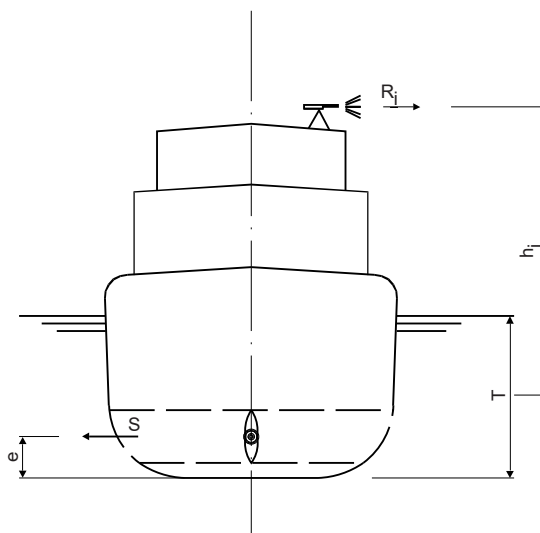

Figure 2 : Reaction force of water jet in the beam direction due to monitors



2 Structure design principles

2.1 Hull structure

2.1.1 The strengthening of the structure of the ships, where necessary to withstand the forces imposed by the fire-extinguishing systems when operating at their maximum capacity in all possible directions of use, are to be considered by the Society on a case-by-case basis.

2.2 Water and foam monitors

2.2.1 The monitors are to be of robust construction and are to be of a type approved by the Society.

The seatings of the monitors are to be of adequate strength for all modes of operation.

3 Other structures

3.1 Arrangement for hull and superstructure openings

3.1.1 On ships which are not fitted with a water-spraying system complying with Sec 4, [3], all windows and port

lights are to be fitted with efficient deadlights or external steel shutters, except for the wheelhouse.

SECTION 3

MACHINERY AND SYSTEMS

1 General

1.1 Application

1.1.1

- a) This Section provides, for ships having the service notations **fire-fighting ship E**, **fire-fighting ship 1**, **fire-fighting ship 2**, and **fire-fighting ship 3**, specific requirements for:
- machinery systems
 - fire-fighting systems installed on board the ship and intended for fighting of external fires.
- b) The requirements related to the self-protection water-spraying systems fitted to fire-fighting ships having the additional service feature **water spray** are given in Sec 4.

1.2 Documents to be submitted

- 1.2.1** The documents listed in Tab 1 are to be submitted.

2 Design of machinery systems

2.1 Manoeuvrability

2.1.1 General

- a) The ratios between the main ship dimensions and the power of propulsion engines and of engines driving side thrusters are to be adequate and such as to ensure an effective manoeuvrability during fire-fighting operations.
- b) The side thrusters and the main propulsion system are to be capable of maintaining the ship in position in still water and of withstanding the reaction forces of the water monitors even in the most unfavourable combination of operating conditions of such monitors, without requiring more than 80% of the above propulsive power, to prevent engine overload.

Table 1 : Documents to be submitted

No.	A/I (1)	Document (2)
1	I	General arrangement showing the disposition of all fire-fighting equipment
2	A	Details of all fire-fighting equipment such as pumps and monitors, including their capacity, range and trajectory of delivery
3	A	Schematic diagram of the water fire-fighting system
4	A	Plan of the water monitor seating arrangements
5	A	Diagram of local control and remote control system for water monitors
6	A	Schematic diagram of the fixed foam fire-extinguishing system
7	A	Plan of the foam monitor seating arrangements (3)
8	A	Diagram of local control and remote control system for foam monitors (3)
9	A	Specification and plan showing the location of firemen's outfits
10	A	Particulars of the means of keeping the ship in position during fire-fighting operations
11	I	Calculation of the required fuel oil capacity according to [2.2.1] (4)
12	I	Operating manual

(1) A: To be submitted for approval in four copies

I: To be submitted for information in duplicate

(2) Diagrams are also to include, where applicable:

- the (local and remote) control and monitoring systems and automation systems
- the instructions for the operation and maintenance of the piping system concerned (for information).

(3) for ships having the service notation **fire-fighting ship 3**.

(4) for ships having one of the following service notations: **fire-fighting ship 1**, **fire-fighting ship 2**, **fire-fighting ship 3**.

2.1.2 Power control system

An operating control system of the power supplied by the engines is to be provided, including:

- an alarm device operating at 80% of the maximum propulsive power available in free navigation, and
- an automatic reduction of power on reaching 100% of the above propulsive power,

to prevent engine overload.

Note 1: Such operating control system may not be required, at the discretion of the Society, in cases where the installed power is redundant.

2.2 Fuel oil capacity

2.2.1 All ships are to have fuel oil tanks whose capacity is to be sufficient for continuous fighting of fires whilst all the water monitors are operating for a period of time not less than:

- 24 hours in the case of ships having the service notation **fire-fighting ship 1**
- 96 hours in the case of ships having the service notation **fire-fighting ship 2** or **fire-fighting ship 3**.

This capacity is to be additional to that provided for the normal operation of the ship (propulsion, etc.).

Note 1: The determination of such required capacity is the responsibility of the Designer.

2.3 Scuppers

2.3.1 When the ship is protected by a water-spraying system, suitable scuppers or freeing ports are to be provided to ensure efficient drainage of water accumulating on deck surfaces when such system is in operation.

3 General requirements for fire-fighting systems

3.1 General

3.1.1 This Article applies to both water fire-extinguishing systems and fixed foam fire-extinguishing systems.

3.2 Independence of pumping and piping systems

3.2.1 The piping system serving the water and foam monitors are not to be used for other services except for the water-spraying system referred to in Sec 4.

3.2.2 Where the water monitor pumps are also used for the water-spraying system referred to in Sec 4, it is to be possible to segregate the two systems by means of a valve.

3.2.3 The piping system from the pumps to the water monitors is to be separate from the piping system to the hose

connections required for the portable fire-fighting equipment referred to in [6.2].

3.3 Design and construction of piping systems

3.3.1 General

- Fire-fighting piping systems are to comply with the provisions of Pt C, Ch 1, Sec 10.
- The maximum design water velocity is not normally to exceed 2 m/s in the suction line.

3.3.2 Sea suction

- Sea suction for fire-fighting pumps are not to be used for other purposes.
- Sea suction and associated sea chests are to be so arranged as to ensure a continuous and sufficient water supply to the fire-fighting pumps, not adversely affected by the ship motion or by water flow to or from bow thrusters, side thrusters, azimuth thrusters or main propellers.
- Sea suction are to be located as low as practicable to avoid:
 - clogging due to debris or ice
 - oil intake from the surface of the sea.
- Sea water inlets are to be fitted with gratings having a free passage area of at least twice that of the sea suction valve. Efficient means are to be provided for clearing the gratings.

3.3.3 Pumps

- Means are to be provided to avoid overheating of the fire-fighting pumps when they operate at low delivery rates.
- The starting of fire-fighting pumps when sea water inlet valves are closed is either to be prevented by an interlock system or to trigger an audible and visual alarm.

3.3.4 Valves

- A sea water suction valve and water delivery valve with a nominal diameter exceeding 450 mm are to be provided with a power actuation system as well as a manual operation device.
- The sea water suction valve and water delivery valve and pump prime movers are to be operable from the same position.

3.3.5 Protection against corrosion

Means are to be provided to ensure adequate protection against:

- internal corrosion, for all piping from sea water inlets to water monitors
- external corrosion, for the lengths of piping exposed to the weather.

3.3.6 Piping arrangement

Suction lines are to be as short and straight as practicable.

3.4 Monitors

3.4.1 Design of monitors

- a) Monitors are to be of a type approved by the Society.
- b) Monitors are to be of robust construction and capable of withstanding the reaction forces of the water jet.

3.4.2 Support of the monitors

The seatings of the monitors are to be of adequate strength for all mode of operations.

3.5 Monitor control

3.5.1 General

Water monitors and foam monitors are to be operated and controlled with a remote control system located in a common control station having adequate overall visibility.

3.5.2 Manual control

In addition to the remote control system, a local manual control is to be arranged for each monitor. It is to be possible to:

- disconnect the local manual control from the control station
- disconnect the remote control system, from a position close to each monitor, to allow the operation with the local manual control.

3.5.3 Valve control

The valve control is to be designed so as to prevent pressure hammering.

3.5.4 Control system

- a) The control system is to comply with the relevant provisions of Pt C, Ch 3, Sec 1 and Pt C, Ch 3, Sec 2.
- b) The control system is to be designed with a redundancy level such that lost function can be restored within 10 minutes.
- c) In the case of a hydraulic or pneumatic control system, the control power units are to be duplicated.

3.5.5 Marking

All control and shut-off devices are to be clearly marked, both locally and in the control station.

4 Water fire-fighting system

4.1 Characteristics

4.1.1

- a) For ships having the service notation **fire-fighting ship 1**, **fire-fighting ship 2** or **fire-fighting ship 3**, the number of pumps and monitors and their characteristics are to be in accordance with the requirements given in Tab 2.
- b) For ships having the service notation **fire-fighting ship E**, the characteristics of the water fire-fighting system will be given special consideration by the Society.

4.2 Monitors

4.2.1 Monitors are to be so arranged as to allow an easy horizontal movement of at least 90° equally divided about the centreline of the ship. The allowed vertical angular movement is to be such that the height of throw required in Tab 2 can be achieved.

4.2.2 The monitors are to be located such that the water jet is free from obstacles, including ship's structure and equipment.

4.2.3 The monitors are to be capable of throwing a continuous full water jet without significant pulsations and compacted in such a way as to be concentrated on a limited surface.

4.2.4 At least two monitors are to be equipped with a device to make the dispersion of the water jet (spray jet) possible.

Table 2 : Number of pumps and monitors and their characteristics (1/7/2004)

Required characteristics	Service notations				
	fire-fighting ship 1	fire-fighting ship 2		fire-fighting ship 3	
minimum number of water monitors	2	2	3	4	4
minimum discharge rate per monitor (m ³ /h)	1200	3600	2400	1800	2400
minimum number of fire-fighting pumps	1	2		2	
minimum total pump capacity (m ³ /h) (1)	2400	7200		9600	
length of throw of each monitor (m) (2) (4)	120	150		150	
height of throw of each monitor (m) (3) (4)	45	70		70	
<p>(1) Where the water monitor pumps are also used for the self-protection water-spraying system, their capacity is to be sufficient to ensure the simultaneous operation of both systems at the required performances.</p> <p>(2) Measured horizontally from the monitor outlet to the mean impact area.</p> <p>(3) Measured vertically from the sea level, the mean impact area being at a distance of at least 70 m from the nearest part of the ship.</p> <p>(4) The length and height of throw are to be capable of being achieved with the required number of monitors operating simultaneously in the same direction.</p>					

4.3 Piping

4.3.1 The maximum design water velocity is not normally to exceed 4 m/s in the piping between pumps and water monitors.

5 Fixed foam fire-extinguishing system

5.1 General

5.1.1 (1/1/2007)

- Ships having the service notation **fire-fighting ship 3** are to be equipped with a fixed low expansion foam monitor system complying with the provisions of this Article.
- Where a fixed low expansion foam monitor system is fitted on a ship having the service notation **fire-fighting ship 1** or **fire-fighting ship 2**, the arrangement and characteristics of the system will be considered by the Society on a case-by-case basis.
- For ships having the service notation **fire-fighting ship E**, some relaxation in the provisions of this Section may be accepted by the Society.

5.2 Characteristics

5.2.1 Foam expansion ratio

The foam expansion ratio is not to exceed 12.

5.2.2 Foam monitors

- The ship is to be fitted with two foam monitors, each having a foam solution capacity not less than 300 m³/h.
- The height of throw is to be at least 50 m above the sea level, when both monitors are in operation at the maximum foam production rate.

5.2.3 Foam concentrate capacity

Sufficient foam concentrate is to be available for at least 30 min of simultaneous operation of both monitors at maximum capacity.

Note 1: When determining the necessary quantity of foam concentrate, the concentration rate is assumed to be 5%.

5.3 Arrangement

5.3.1 Foam generating system

The foam generating system is to be of a fixed type with separate foam concentrate tank, foam-mixing units and piping to the monitors.

5.3.2 Pumps

The pumps of the water monitor system may be used for supplying water to the foam monitor system. In such case, it may be necessary to reduce the pump water delivery pressure to ensure correct water pressure for maximum foam generation.

6 Portable fire-fighting equipment

6.1 Portable high expansion foam generator

6.1.1 Ships having the service notation **fire-fighting ship 2** or **fire-fighting ship 3** are to be equipped with a portable high expansion foam generator having a foam capacity not less than 100 m³/min for fighting of external fires.

6.1.2 The total capacity of foam concentrate is to be sufficient for 30 min of continuous foam production. The foam concentrate is to be stored in portable tanks of about 20 litres capacity.

6.2 Hydrants and fire hoses

6.2.1 Hydrants

- Hydrants are to be provided in accordance with Tab 3.
- At least half of the required hydrants are to be arranged on the main weather deck.
- Where hydrants are fed by the pumps serving the monitor supply lines, provision is to be made to reduce the water pressure at the hydrants to a value permitting safe handling of the hose and the nozzle by one man.

6.2.2 Fire hose boxes

- At least one box containing fire hoses is to be provided for every two hydrants.
- Each box is to contain two fire hoses complete with dual-purpose (spray/jet) nozzles.

6.2.3 Fire hoses

- Fire hoses and associated nozzles are to be of a type approved by the Society.
- Fire hoses are to be of 45 to 70 mm in diameter and generally are to be 20 m in length.

Table 3 : Number of hydrants

fire-fighting ship E	fire-fighting ship 1	fire-fighting ship 2	fire-fighting ship 3
4 at each side	4 at each side	8 at each side	8 at each side (1)
(1) May be increased to 10 hydrants at each side, depending on the ship's length.			

7 Firemen's outfits

7.1 Number and characteristics

7.1.1 (1/1/2007)

The total number of firemen's outfits to be fitted on board is to be in accordance with Tab 4.

Table 4 : Number of firemen's outfits

fire-fighting ship E	fire-fighting ship 1	fire-fighting ship 2	fire-fighting ship 3
4	4	8	8

7.1.2 The air breathing apparatuses, protective clothing and electric safety lamps constituting parts of firemen's outfits are to be of a type approved by the Society.

7.1.3 Breathing apparatuses are to be of the self-contained type. They are to have a capacity of at least 1200 litres of free air.

At least one spare air bottle is to be provided for each apparatus.

7.1.4 The firemen's outfits are to be stored in a safe position readily accessible from the open deck.

7.2 Compressed air system for breathing apparatuses

7.2.1 General

All ships are to be equipped with a high pressure air compressor complete with all fittings necessary for refilling the bottles of air breathing apparatuses. The compressor is to be located in a suitable sheltered location.

7.2.2 Capacity

The capacity of the compressor is to be sufficient to allow the refilling of the bottles of air breathing apparatuses in no more than 30 min. This capacity is not to be less than 75 l/min.

7.2.3 Accessories

- The compressor is to be fitted on the air suction with a suitable filter.
- The compressor is to be fitted on the delivery with oil separators and filters capable of preventing passage of oil droplets or vapours to the air bottles.

8 Testing

8.1 General

8.1.1 The provisions of this Article are related to the workshop and on board tests to be carried out for:

- machinery systems
- fire-fighting systems.

They supplement those required in Part C, Chapter 1 for machinery systems.

8.2 Workshop tests

8.2.1 Tests for material

- Materials used for the housing of fire-fighting pumps are to be subjected to a tensile test at ambient temperature according to the relevant provisions of Part D.
- Materials used for pipes, valves and other accessories are to be tested in accordance with the provisions of Pt C, Ch 1, Sec 10, [21.3].

8.2.2 Hydrostatic testing

After completion of manufacture and before installation on board, pipes, valves, accessories and pump housings are to be submitted to a hydrostatic test in accordance with the provisions of Pt C, Ch 1, Sec 10, [21.4].

8.3 On board tests

8.3.1 Fixed fire-fighting systems

- After assembly on board, the water fire-fighting system and the fixed foam fire-extinguishing system are to be checked for leakage at normal operating pressure.
- The water fire-fighting system and fixed foam fire-extinguishing system are to undergo an operational test on board the ship, to check their characteristics and performances.

8.3.2 Propulsion and manoeuvring systems

- A test is to be performed to check the manoeuvring capability of the ship.
- The capability of the side thrusters and of the main propulsion system to maintain the ship in position with all water monitors in service without requiring more than 80% of the propulsive power is to be demonstrated.

SECTION 4 FIRE PROTECTION AND EXTINCTION

1 General

1.1 Application

1.1.1 (1/1/2007)

This Section provides, for ships having the service notations fire-fighting ship 1, fire-fighting ship 2 and fire-fighting ship 3, specific requirements for:

- fire protection
- self-protection water-spraying system.

1.1.2 For ships having the service notation **fire-fighting ship E**, fire protection arrangements will be given special consideration by the Society.

1.2 Documents to be submitted

1.2.1 The documents listed in Tab 1 are to be submitted for approval.

2 Fire protection of exposed surfaces

2.1 Structural fire protection

2.1.1 (1/7/2003)

- On ships having the service notation **fire-fighting ship 1**, all exterior boundaries above the lightest operating waterline, including superstructures and exposed decks, are to be of steel and are to be internally insulated so as to form A-60 class divisions unless they are self-protected with a water-spraying system having a capacity of not less than 10 l/min for each square metre (see also [3.2.1]).
- On ships having the service notation **fire-fighting ship 2** or **fire-fighting ship 3**, all exterior boundaries are to be of steel but they need not be insulated.
- On all ships, other boundaries may be constructed of materials other than steel, subject to special consideration by the Society.

2.2 Deadlights and shutters

2.2.1 On ships for which the additional service feature **water spray** is not assigned, steel deadlights or external steel

shutters are to be provided on all windows, sidescuttles and navigation lights, except for the windows of the navigating bridge.

3 Self-protection water-spraying system

3.1 General

3.1.1 (1/1/2007)

The provisions of this Article apply to the self-protection water-spraying systems fitted to ships having the additional service feature **water spray**.

3.2 Capacity

3.2.1 The capacity of the self-protection water-spraying system is to be not less than 10 l/min for each square metre of protected area. In the case of surfaces which are internally insulated, such as to constitute A-60 class divisions, a lower capacity may be accepted, provided it is not less than 5 l/min for each square metre of protected area.

3.3 Arrangement

3.3.1 Areas to be protected

The fixed self-protection water-spraying system is to provide protection for all vertical areas of the hull and superstructures as well as monitor foundations and other fire-fighting arrangements, and is to be fitted in such a way as not to impair the necessary visibility from the wheelhouse and from the station for remote control of water monitors, also during operation of spray nozzles.

3.3.2 Sections

The fixed self-protection water-spraying system may be divided into sections so that it is possible to isolate sections covering surfaces which are not exposed to radiant heat.

3.3.3 Spray nozzles

The number and location of spray nozzles are to be suitable to spread the sprayed water uniformly on areas to be protected.

Table 1 : Documents to be submitted

No.	A/I (1)	Document
1	A	Plan showing the structural fire division, including doors and other closing devices of openings in A and B class divisions
2	I	Fire test reports for insulating materials
3	A	Schematic diagram of the fixed self-protection water-spraying system
(1) A: To be submitted for approval in four copies I: To be submitted for information in duplicate		

3.4 Pumps

3.4.1 Use of pumps serving other systems (1/1/2007)

The following pumps may be used for the self-protection water-spraying system:

- fire pumps supplying the fire main system
- water monitor system pumps referred to in Sec 3, [4].

In this case, a shut-off valve is to be provided to segregate the systems concerned.

3.4.2 Capacity of the pumps

- The pumps of the self-protection water-spraying system are to have a capacity sufficient to spray water at the required pressure from all spray nozzles of the system.
- Where the pumps serving the self-protection water-spraying systems are also used for another service, their

capacity is to be sufficient to ensure the simultaneous operation of both systems at the required performances.

3.5 Piping system and spray nozzles

3.5.1 General

Pipes are to be designed and manufactured according to the requirements of Pt C, Ch 1, Sec 10.

3.5.2 Protection against corrosion

Steel pipes are to be protected against corrosion, both internally and externally, by means of galvanising or equivalent method.

3.5.3 Drainage cocks

Suitable drainage cocks are to be arranged and precautions are to be taken in order to prevent clogging of spray nozzles by impurities contained in pipes, nozzles, valves and pumps.

Part E
Service Notations

Chapter 17
OIL RECOVERY SHIPS

- SECTION 1 GENERAL**
- SECTION 2 HULL AND STABILITY**
- SECTION 3 MACHINERY AND SYSTEMS**
- SECTION 4 ELECTRICAL INSTALLATIONS**
- SECTION 5 FIRE PROTECTION, DETECTION AND EXTINGUISHION**

SECTION 1

GENERAL

1 General

1.1 Application

1.1.1 (1/1/2012)

Ships complying with the requirements of this Chapter are eligible for the assignment of the service notation oil recovery ship, as defined in Pt A, Ch 1, Sec 2, [4.8.5].

If the ship collects only oil with flashpoint exceeding 60°C, this restriction will be reported on the ship operation manual and the service feature flash point > 60°C is assigned.

In the case of ships provided with tanks dedicated to the containment of oil both with flashpoint \leq 60°C and with flashpoint > 60°C, in the ship operation manual (see Sec 3, Tab 1) and in the ship documents it is to be clearly indicated for each tank which is the allowed flashpoint of the oil contained therein.

1.1.2 (1/7/2011)

Ships dealt with in this Chapter are to comply with the requirements stipulated in Parts A, B, C and D, as applicable, and with the requirements of this Chapter, which are specific to oil recovery ships.

1.2 Summary table

1.2.1 Tab 1 indicates, for ready reference, the Sections of this Chapter containing specific requirements applicable to oil recovery ships.

Table 1 (1/1/2007)

Main subject	Reference
Ship arrangement	(1)
Hull and stability	Sec 2
Machinery and systems	Sec 3
Electrical installations	Sec 4
Automation	(1)
Fire protection, detection and extinction	Sec 5
(1) No specific requirements for oil recovery ships are given in this Chapter.	

SECTION 2

HULL AND STABILITY

1 General

1.1 Oil removal

1.1.1 Oil removal is to be performed by conveying with suitable apparatuses the top layers of polluted water collected by the ship moving ahead into separation tanks and/or by skimming mobile belts or rotating disks acting on the oil film and/or by means of floating suction pumps operating on the sea surface.

Alternative methods, equivalent to those mentioned, are to be considered by the Society on a case-by-case basis.

1.2 Definitions

1.2.1 Accumulation tank

An accumulation tank is a tank intended for the retention of oil removed and separated from sea water.

1.2.2 Settling tank

A settling tank is a tank intended for the retention of polluted water and its subsequent separation from oil.

2 General arrangement design

2.1 Segregation of spaces intended for retention of oil

2.1.1 Tanks (1/7/2011)

Accumulation tanks are to be separated from the engine room and service and accommodation spaces, by means of a cofferdam or equivalent space.

Fuel tanks, settling tanks, tanks for ballast water, foam-forming liquid or anti-pollution liquid, storerooms for oil removal equipment and pump rooms are considered equivalent to a cofferdam.

This cofferdam may be omitted, however, between the above-mentioned spaces and

- settling tanks
- accumulation tanks that are dedicated to the retention of oil with flashpoint > 60°C only.

In the case of tanks containing foam-forming liquid having a bulkhead adjacent to accumulation tanks, fuel oil tanks or dispersing liquid tanks, the scantlings of such bulkhead and associated welds are to be adequately increased.

2.1.2 Openings in accumulation tank ceilings

All openings in accumulation tank ceilings are to lead to the open.

2.1.3 Location of the accumulation tanks

Accumulation tanks are to be located abaft the collision bulkhead.

2.1.4 Movable tanks

In the case of oil collected in movable tanks fitted on the weather deck, the location of such tanks is to be such as to comply with the requirements in Sec 3, [4.2] relevant to gas vents.

2.2 Dangerous spaces

2.2.1 (1/7/2002)

Dangerous spaces are those indicated in Sec 4, [3] and Sec 4, Tab 1.

2.3 Access to safe spaces

2.3.1 (1/7/2002)

See Sec 4, [3.1.3].

3 Stability

3.1 Intact stability

3.1.1 General

The stability of the ship for the loading conditions reported in the trim and stability booklet is to be in compliance with the requirements in Pt B, Ch 3, Sec 2.

4 Design loads

4.1 Oil removal and spraying

4.1.1 The still water and inertial loads transmitted by the operation of apparatuses and/or equipment for oil removal and spraying of any dispersant to the hull structure are to be taken into account.

5 Hull scantlings

5.1 Accumulation tanks

5.1.1 The net scantlings of any accumulation tanks consisting of movable tanks are considered by the Society on a case-by-case basis.

6 Other structures

6.1 Hull and superstructure openings

6.1.1 Windows in safe spaces located in front of dangerous spaces, where not of the fixed type, are to be such as to ensure an efficient gas-tight closure.

7 Construction and testing

7.1 Testing

7.1.1 Oil removal equipment

On completion of construction, a test is to be carried out on all equipment for oil removal in order to check:

- safeguards against fire and explosions during operations involving removal, retention on board, carriage and unloading of oil spilled on the sea surface
- structural strength in relation to stresses caused by equipment used during oil removal operations.

SECTION 3

MACHINERY AND SYSTEMS

1 General

1.1 Application

1.1.1 (1/7/2012)

This Section provides, for ships having the service notation oil recovery ship, specific requirements for:

- machinery systems
- recovered oil pumping and piping systems
- tanks.

The requirements of this Section apply, in addition to those contained in Pt C, Ch 1, Sec 10, to oil recovery ships for collection of oil having flash point not exceeding 60°C, except what specified in items [1], [2.4.1] a), [3.1.1] b) and c), [3.1.2] and [3.2.1] b) which also apply to oil recovery ships for collection of oil having flash point exceeding 60°C.

1.2 Documents to be submitted

1.2.1 The documents listed in Tab 1 are to be submitted.

1.3 Definitions

1.3.1 Gas-dangerous areas

Gas-dangerous areas and zones are defined in Sec 2, [2.2.1].

1.3.2 Accumulation and settling tanks

Accumulation and settling tanks are defined in Sec 2, [1.2].

2 Machinery installations and piping systems not intended for recovered oil

2.1 Bilge system

2.1.1 Arrangements are to be provided to drain the recovered oil pump room by means of power pumps or a bilge ejector.

Note 1: On oil recovery ships of less than 500 tons gross tonnage, the pump room may be drained by means of hand pumps with a suction diameter of not less than 50 mm.

2.2 Sea water cooling system

2.2.1 One of the suctions serving the sea water cooling system (see Pt C, Ch 1, Sec 10, [10.7.1]) is to be located in the lower part of the hull.

2.3 Water fire-extinguishing system

2.3.1 Sea suctions serving the fire water pumps are to be located as low as possible.

2.4 Exhaust gas systems

2.4.1

- a) Exhaust lines from engines, gas turbines, boilers and incinerators are to be led to a gas-safe position as high as practicable above the deck and are to be fitted with a spark arrester.
- b) Where the distance between the exhaust lines of engines and the dangerous zones is less than 3 m, the ducts are to be fitted in a position:
 - near the waterline if cooled by water injection, or
 - below the waterline in other cases.

2.5 Additional requirements for machinery installations in gas-dangerous areas

2.5.1 Attention is drawn to the risk of ignition in gas-dangerous spaces from sparking due to:

- formation of static electricity, or
- friction between moving parts.

2.5.2 No part having a surface temperature exceeding 220°C is permitted within the gas-dangerous areas.

2.5.3 Where precautions are taken against the risk of ignition, the installation of internal combustion engines may be permitted in zone 2 open gas-dangerous areas, subject to special consideration by the Society.

3 Pumping system, piping system and pump rooms intended for recovered oil

3.1 Design of pumping and piping systems

3.1.1 General

- a) The relevant provisions of Ch 7, Sec 4, [3] and Pt C, Ch 1, Sec 10 are to be complied with.
- b) Except where otherwise permitted by the Society, pumping and piping systems intended for recovered oil are to be independent from other pumping and piping systems of the ship.
- c) Piping is to be permanently installed. However, the use of portable pumps may be permitted, subject to special consideration by the Society.

3.1.2 Systems for oil recovery

Oil recovery is to be performed:

- by conveying with suitable systems the top layers of polluted water collected by the ship moving ahead into separation tanks, and/or
- by skimming mobile belts or rotating disks acting on the oil film, and/or
- by means of floating suction pumps operating on the sea surface.

Alternative methods will be specially considered by the Society.

3.1.3 System for unloading oil residues

Ships fitted with structural accumulation tanks are to be equipped with a system enabling the unloading of oil residues contained in accumulation tanks to shore facilities or to a supply vessel, simultaneously with oil recovery.

3.2 Arrangement of piping systems and pump rooms

3.2.1 Piping systems (1/7/2010)

- a) Piping systems for handling of oil recovered are not to pass through accommodation spaces.

Piping handling oil with flashpoint $\leq 60^{\circ}\text{C}$ is allowed to pass through the following spaces provided that piping joints are of welded type:

- machinery spaces,
- service spaces,
- other enclosed gas-safe spaces.

- b) Where the transfer of recovered oil into accumulation tanks is carried out by means of flexible hoses or movable piping, only suitable connections are to be used. Small hatches are not permitted.

3.2.2 Pump rooms (1/1/2007)

- a) Pump rooms containing the pumps for handling the recovered oil are to comply with the provisions given in Chapter 7 for pump rooms of ship having the service notation **oil tanker**.
- b) For draining of pump rooms, see [2.1.1].

3.2.3 (1/7/2006)

The separated oil is to be transferred from the settling tanks to the accumulation tanks.

In this way a pipe branch connection is to be provided between the settling tanks and the accumulation tanks.

The branch connection is to be provided with a suction pipe fitted at an adequate height inside the settling tanks where it is possible to collect the separated oil.

A dedicated system is to be provided to collect and discharge the water separated from the oil inside the settling tanks.

The instructions to the crew relevant to the removal of the separated oil from the settling tanks to the accumulation tanks are to be duly indicated in the operation manual.

4 Settling and accumulation tanks

4.1 General

4.1.1 The arrangement of settling and accumulation tanks is to comply with the provisions of Sec 2, [2.1.1].

4.2 Vent pipes

4.2.1 Settling tanks

Vent pipes of settling tanks are to be fitted with:

- adequate flameproof wire gauze, and
- closing appliances complying with the provisions of Pt C, Ch 1, Sec 10, [9.1].

4.2.2 Accumulation tanks

- a) Vent pipes of accumulation tanks are to lead to the open at least 2 m above the weather deck and are to be located at least 5 m from ignition sources, openings in accommodation spaces and other safe spaces, and air intakes of ventilation systems for accommodation spaces, engine rooms and other safe spaces in which ignition sources may be present.

- b) Openings of vent pipes to the open are to be so arranged as to allow a direct flow upwards and fitted with:

- flameproof wire gauze made of corrosion resistant material easily removable for cleaning, and
- closing appliances complying with the provisions of Pt C, Ch 1, Sec 10, [9.1].

4.3 Level gauging and overfilling control

4.3.1 Level gauging

- a) Accumulation tanks are to be fitted with sounding pipes or other level gauging devices of a type approved by the Society.
- b) Sounding pipes in accumulation tanks are to terminate in the open air.

4.3.2 Overfilling control

- a) Accumulation tanks are to be fitted with a high level alarm, an overflow control system or equivalent means to prevent the liquid from rising in the vent pipes.
- b) The high level alarm is to be of a type approved by the Society and is to give an audible and visual alarm at the control station.

4.4 Heating systems

4.4.1 Heating systems fitted to accumulation tanks are to comply with the provisions of Ch 7, Sec 4, [2.6].

Table 1 : Documents to be submitted (1/7/2002)

No.	A/I (1)	Document (2)
1	I	General plan of the system for oil recovery and specification of all relevant apparatuses
2	A	Schematic arrangement of recovered oil piping and pumping systems
3	A	Tank venting arrangement
4	I	Procedure and limiting conditions for recovering oil, cargo transfer, tank cleaning, gas freeing and ballasting (operation manual)
<p>(1) A: To be submitted for approval in four copies I: To be submitted for information in duplicate</p> <p>(2) Diagrams are also to include, where applicable, the (local and remote) control and monitoring systems and automation systems.</p>		

SECTION 4

ELECTRICAL INSTALLATIONS

1 General

1.1 Application

1.1.1 (1/1/2007)

The requirements in this Section apply, in addition to those contained in Part C, Chapter 2, to oil recovery ships for collection of oil having flashpoint not exceeding 60°C.

1.2 Documentation to be submitted

1.2.1 (1/1/2007)

In addition to the documentation requested in Pt C, Ch 2, Sec 1, [2.1.1], the following is to be submitted for approval:

- a) plan of dangerous areas
- b) document giving details of types of cables and safety characteristics of the equipment installed in hazardous areas
- c) diagrams of tank level indicator systems, high level alarm systems and overflow control systems where requested.

2 Design requirements

2.1 System of supply

2.1.1 (1/1/2007)

Earthed systems with hull return are not permitted, with the following exceptions to the satisfaction of the Society:

- a) impressed current cathodic protective systems
- b) limited and locally earthed systems, such as starting and ignition systems of internal combustion engines, provided that any possible resulting current does not flow directly through any hazardous area
- c) insulation level monitoring devices, provided that the circulation current of the device does not exceed 30 mA under the most unfavourable conditions
- d) intrinsically safe systems.

2.1.2 In insulated distribution systems, no current carrying part is to be earthed, other than:

- a) through an insulation level monitoring device
- b) through components used for the suppression of interference in radio circuits.

2.2 Earth detection

2.2.1 (1/1/2007)

For both insulated and earthed distribution systems a device, or devices, are to be installed to continuously monitor the insulation to earth and to give an audible and visual alarm at a manned position in the event of an abnormally

low level of insulation resistance and/or high level of leakage current.

The above is not applicable to systems mentioned in [2.1.1].

3 Hazardous locations and types of equipment

3.1 Electrical equipment permitted in hazardous areas

3.1.1 (1/1/2007)

Electrical equipment permitted in hazardous areas is that indicated in Pt C, Ch 2, Sec 3, [10.1.4], Pt C, Ch 2, Sec 3, [10.1.5], and Pt C, Ch 2, Sec 3, [10.1.6].

In addition, in Zone 1 and Zone 2, the installation of the following is permitted: hull fittings containing the terminals or shell plating penetrations for anodes or electrodes of an impressed current cathodic protection system, or transducers such as those for depth sounding or log systems, provided that such fittings are of gas-tight construction or housed within a gas-tight enclosure, and are not located adjacent to a cargo tank bulkhead. The design of such fittings or their enclosures and the means by which cables enter, as well as any testing to establish their gas-tightness, are to be to the satisfaction of the Society. The associated cables are to be protected by means of heavy gauge steel pipes with gas-tight joints.

3.1.2 The explosion group and temperature class of electrical equipment of a certified safe type are to be at least IIA and T3.

3.1.3 There are normally not to be access doors or other openings between a safe space, such as accommodation or service spaces, engine rooms and similar spaces, and a hazardous area.

Access doors may, however, be accepted between such spaces and hazardous areas, provided that:

- a) safe spaces are fitted with forced ventilation in order to maintain an overpressure therein
- b) access doors are:
 - 1) of a self-closing type and arranged to swing into the safer space, so that they are kept closed by the overpressure, with the self-closing device capable of shutting the doors against an inclination of 3,5° opposing closure, without hold-back hooks keeping them in an open position, or
 - 2) gas-tight, kept closed during oil recovery operation until gas freeing is carried out, and provided with a warning plate (suitable instructions are given in the oil recovery manual).

3.2 Hazardous area classification

3.2.1 (1/1/2007)

For hazardous area classification see Tab 1.

Table 1 : Classification of hazardous areas for oil recovery ships for collection of oil having flashpoint not exceeding 60°C (1/1/2007)

Spaces		Hazardous area
No.	Description	
1	Accumulation tanks, pipes and equipment containing the recovered oil.	Zone 0
2	Cofferdams and enclosed or semi-enclosed spaces adjacent to or immediately above accumulation tanks, unless fitted with forced ventilation capable of giving at least 20 air changes per hour and having characteristics such as to maintain the effectiveness of such ventilation.	Zone 1
3	Spaces containing pumps for the handling of recovered oil.	Zone 1
4	Double bottoms or duct keels located under accumulation tanks.	Zone 1
5	Enclosed or semi-enclosed spaces immediately above pump rooms for the hauling of recovered oil or above vertical cofferdams adjacent to accumulation tanks unless separated by a gas-tight deck and fitted with forced ventilation capable of giving at least 20 air changes per hour having characteristics such as to maintain the effectiveness of such ventilation.	Zone 1
6	Enclosed or semi-enclosed spaces containing pipes, valves or other equipment for the handling of recovered oil unless fitted with forced ventilation capable of giving at least 20 air changes per hour and having characteristics such as to maintain the effectiveness of such ventilation.	Zone 1
7	Areas on open deck, or semi-enclosed spaces on open deck within 3 m from equipment for oil recovery, hatches or any other openings in accumulation tanks and any pump for the handling of recovered oil not fitted in a pump room.	Zone 1
8	Areas on open deck over all accumulation tanks up to a height of 2,4 m above the deck.	Zone 1
9	Enclosed or semi-enclosed spaces for floating pumps and associated hoses and other equipment which may similarly contain residues of recovered oil.	Zone 1
10	Areas indicated in Sec 3, [4.2.2] a).	Zone 1

SECTION 5

FIRE PROTECTION, DETECTION AND EXTINCTION

1 General

1.1 Application

1.1.1 (1/7/2009)

For ships having the service notation **oil recovery ship**, this Section provides specific requirements addressing safety against fire and explosion during handling, storage and transportation of oil recovered from the sea.

For oil recovery ships intended to collect only oil having a flashpoint exceeding 60°C, the requirements of [2] and [3.3] do not apply.

The application of the requirements of this Section to ships of less than 500 gross tonnage and classed for restricted navigation will be specially considered by the Society in each case.

1.2 Documents to be submitted

1.2.1 (1/7/2008)

The documents listed in Tab 1 are to be submitted for approval.

1.3 Definitions

1.3.1 (1/7/2008)

- a) Gas-dangerous areas and zones are defined in Sec 2, [2.2.1].
- b) Accumulation tanks are defined in Sec 2, [2.1.1].

2 Ventilation systems

2.1 General

2.1.1 (1/7/2008)

Gas-dangerous spaces are to have a ventilation system independent from that serving gas-safe spaces.

2.1.2 (1/7/2008)

Ventilation systems are to be so arranged as to avoid the formation of gas pockets.

2.1.3 (1/7/2008)

Attention is drawn to the specific ventilation arrangements imposed on certain spaces in order to consider them safe spaces. Refer to Sec 2, [2.2.1].

2.2 Ventilation of recovered oil pump rooms

2.2.1 (1/7/2008)

Recovered oil pump rooms are to be provided with a mechanical ventilation system of the extraction type capable of giving at least 8 air changes per hour.

Note 1: Where the pump room is not normally entered during oil handling, the mechanical ventilation may be omitted.

2.2.2 (1/7/2008)

Ventilation intakes are to be so arranged as to minimise the possibility of recycling hazardous vapours from ventilation discharge openings.

2.2.3 (1/7/2008)

Exhaust and inlet ventilation ducts are to be led upwards to a gas-safe area on the weather deck in locations at least 3 m and 1,5 m, respectively, from any ventilation intake and opening to gas-safe spaces.

2.2.4 (1/7/2008)

Protection screens of not more than 13 mm square mesh are to be fitted on ventilation duct intakes and outlets.

2.2.5 (1/7/2008)

Ventilation fans are to be of non-sparking construction as per Pt C, Ch 4, Sec 1, [5.3].

2.2.6 (1/7/2008)

The ventilation system is to be capable of being controlled from outside the pump room.

2.3 Ventilation of enclosed normally entered dangerous spaces other than cargo pump rooms

2.3.1 (1/7/2008)

Enclosed normally entered dangerous spaces are to be provided with a mechanical ventilation system of the extraction type capable of giving at least 8 air changes per hour.

Table 1 : Documents to be submitted (1/7/2008)

No.	(1)	Documents (2)
1	A	Diagram of the ventilation systems serving: <ul style="list-style-type: none"> • dangerous spaces including pump room • machinery spaces • accommodation spaces
2	A	Specification of flammable gas detectors
3	A	Drawing and specification of the fixed/movable fire-fighting systems and structural fire protection required by this Section
<p>(1) A: To be submitted for approval in four copies</p> <p>(2) Diagrams are also to include, where applicable, the (local and remote) control and monitoring systems and automation systems.</p>		

2.3.2 (1/7/2008)

Ventilation intakes are to be located at a distance of not less than 3 m from the ventilation outlets of pump rooms.

2.4 Ventilation of enclosed safe spaces adjacent to dangerous areas**2.4.1 (1/7/2008)**

Safe spaces adjacent to dangerous areas are to be provided with a mechanical ventilation system capable of maintaining the space with a positive pressure.

2.4.2 (1/7/2008)

Ventilation intakes are to be located in a gas-safe area on the weather deck as far as practicable from the ventilation outlets of gas-dangerous spaces.

3 Fire protection and fire fighting**3.1 General****3.1.1 (1/7/2008)**

Ships having the service notation **oil recovery ship** are to comply with the provisions for fire protection and fire fighting stipulated for cargo ships in Part C, Chapter 4.

3.2 Oil flashpoint and gas measurement systems**3.2.1 General (1/7/2017)**

Where, due to fire or explosion hazards, the ship is required to operate at a safe distance from the source of oil spill, suitable equipment is to be provided to measure the concentration of flammable gases.

For ships intended to collect only oil having a flashpoint exceeding 60°C, suitable equipment is to be provided to measure the oil flashpoint.

3.2.2 Gas measurement system (1/7/2009)

a) A fixed flammable gas detecting system is to be provided in order to check the hydrocarbon gas concentration in the following locations:

- engine room
- open deck (one forward, one astern).

The system is to be capable of giving an alarm in the wheelhouse (or other suitable location) and on the open deck when the vapour concentration of hydrocarbons and similar products in the atmosphere exceeds 30 % of the lower explosive limit of the mixture of such vapours and air.

b) In addition to the fixed system, at least one portable gas detection instrument is to be provided on board.

c) For ships of 200 gross tonnage or less and for ships intended to collect oil having a flashpoint exceeding 60°C, as an alternative to the requirements stated in items a) and b), two portable gas detectors may be accepted.

In addition, for ships of 200 gross tonnage or less but exceeding 18 metres in length and, the following requirements are to be met:

- simultaneous samples are to be obtained for analysis at least every 15 minutes in two different locations (one forward, another astern), and
- the results of these analyses are to be recorded in a register kept for the purpose.

Information regarding these operations is to be clearly recorded in the Operation Manual cited in Sec 3, Tab 1.

3.2.3 Oil flashpoint measurement (1/7/2008)

The equipment for oil flashpoint measurement may be portable.

3.3 Structural fire protection**3.3.1 (1/7/2008)**

Where cargo tanks are arranged forward of the superstructure or aft of the superstructure within 10 m of the nearest gas-dangerous zone, exterior boundaries of superstructures and deckhouses enclosing accommodation and including any overhanging decks which support such accommodation are to be insulated to A-60 standard for the whole of the portions which face the gas-dangerous areas and for a dis-

tance of 3 m aft or forward of such areas. This requirement is also applicable to access doors in such boundaries. Alternatively, insulation to A-0 standard with a permanently installed water-spraying system in compliance with [3.3.3] may be accepted. Aluminium bulkheads will not be accepted in these boundaries.

3.3.2 (1/7/2008)

Portholes or windows in the area specified in [3.3.1] are to have the same fire rating as the bulkhead in which they are fitted. This requirement does not apply to wheelhouse windows. Portholes or windows which have a lower fire rating than that required, or which are to be protected by a water-spraying system in accordance with [3.3.3], are to be fitted with permanently installed inside deadlights of steel having a thickness equal to the steel in the bulkhead in which they are fitted.

3.3.3 (1/7/2008)

If it is impractical to fit deadlights, windows in the area specified in [3.3.1] are to be protected by a sprinkler system having a capacity of at least 10 litres/minute/m². The system is to be fully activated by opening of one valve on the bridge.

3.4 Fire fighting

3.4.1 (1/7/2009)

For the protection of the deck area in way of accumulation tanks, the following fire-fighting equipment is to be provided:

- a) two dry powder fire extinguishers, each with a capacity of at least 50 kg
- b) at least one fire extinguisher having a capacity of at least 45 l.

3.4.2 (1/7/2009)

The foam fire extinguisher is to be capable of producing a foam blanket over the accumulation tanks in order to efficiently reduce the emission of flammable gases.

3.4.3 (1/7/2009)

For ships intended to collect only oil having a flashpoint exceeding 60°C, in lieu of the equipment required in [3.4.1] b), one portable foam applicator with one spare tank is to be provided. The capacity of the portable foam applicator is to be suitable for the deck area to be protected to the Society's satisfaction.

3.4.4 (1/7/2009)

For ships of 200 gross tonnage or less, in lieu of the equipment required in [3.4.1], the portable foam applicator required in [3.4.3] is to be provided.

Part E
Service Notations

Chapter 18

CABLE-LAYING UNITS

- SECTION 1 GENERAL**
- SECTION 2 HULL AND STABILITY**
- SECTION 3 MACHINERY AND SYSTEMS**

SECTION 1

GENERAL

1 General

1.1 Application

1.1.1 (1/1/2022)

Ships complying with the requirements of this Chapter are eligible for the assignment of the service notation **cable laying unit**, as defined in Pt A, Ch 1, Sec 2, [4.8.7].

1.1.2 (1/1/2022)

Ships dealt with in this Chapter are to comply with the requirements stipulated in Parts A, B, C and D, as applicable, and with the requirements of this Chapter, which are specific to cable laying units.

1.2 Summary table

1.2.1 (1/1/2022)

Tab 1 indicates, for ready reference, the Sections of this Chapter containing specific requirements applicable to cable laying units.

Table 1 (1/1/2022)

Main subject	Reference
Ship arrangement	(1)
Hull and stability	Sec 2
Machinery and systems	Sec 3
Electrical installations	(1)
Automation	(1)
Fire protection, detection and extinction	(1)
(1) No specific requirements for cable laying units are given in this Chapter.	

SECTION 2

HULL AND STABILITY

1 General

1.1 Application

1.1.1 The requirements of this Section apply to ships fitted, in general, with one or more continuous decks, suitable holds for the carriage of cables and superstructures extending for most of the ship's length.

The main characteristics of the ship may vary according to the service primarily performed which may be as follows:

- laying (and possibly burying) submarine cables on the sea bed
- hauling and repairing submarine cables.

2 Stability

2.1 Intact stability

2.1.1 General

The stability, the freeboard and the metacentric radius or roll period are to be such as to ensure:

- satisfactory seakeeping performance in working conditions
- a steady working platform in order to facilitate the performance of cable laying and/or repair operations.

Anti-roll tanks or bilge keels of adequate size may be fitted to meet the above requirements.

2.1.2 Tanks intended for liquid consumable

Special attention is to be paid to the arrangement of tanks intended to contain liquid consumables in order to prevent weight variations during service resulting in excessive changes in the ship's trim.

At the same time the arrangement of ballast water tanks is to be such as to ensure the best ship's trim, in any loading condition, for the performance of all work for which the ship is intended.

2.1.3 Intact stability criteria

The stability of the ship for the loading conditions in Pt B, Ch 3, App 2, [1.2.1] and for the (departure and arrival) loading conditions corresponding to the maximum draught is to be in compliance with the requirements in Pt B, Ch 3, Sec 2.

3 Hull scantlings

3.1 Cable tanks

3.1.1 The net scantlings of cable tanks are to be obtained through direct calculations to be carried out according to Pt B, Ch 7, App 1, where the still water and wave loads are to be calculated for the most severe condition of use.

3.2 Connection of the machinery and equipment with the hull structure

3.2.1 The net scantlings of the structures in way of the connection between the hull structure and the machinery and equipment, constituting the laying or hauling line for submarine cables, are to be obtained through direct calculation to be carried out according to Pt B, Ch 7, App 1, based on the service loads of such machinery and equipment, as specified by the Designer.

In calculating these above service loads, the Designer is to take into account the inertial loads induced by ship motions in the most severe condition of use.

4 Other structures

4.1 Fore part

4.1.1 In general, a high freeboard is needed in the forward area, where most repair work is carried out, in order to provide adequate safety and protection against sea waves.

5 Hull outfitting

5.1 Equipment

5.1.1 Hawse pipes

Hawse pipes are to be integrated into the hull structure in such a way that anchors do not interfere with the cable laying.

5.1.2 Sheaves

Where there is a risk that, in rough sea conditions, sheaves are subjected to wave impact loads, special solutions such as the provision of retractable type sheaves may be adopted.

SECTION 3

MACHINERY AND SYSTEMS

1 General

1.1 Propulsion and manoeuvrability

1.1.1 The main propulsion systems of cable laying and/or repair ships are to be capable of:

- a) maintaining an adequate speed during the transit condition
- b) ensuring a satisfactory manoeuvrability at the speed assumed by the Designer for the performance of cable laying and/or repair operations.

1.2 Documents to be submitted

1.2.1 Tab 1 lists the documents which are to be submitted.

Table 1

No.	A/I (1)	Document
1	I	General arrangement of the cable laying equipment
2	I	Design loads on all components of the cable laying equipment
3	A	Structural plans of all components of the cable laying equipment, including gears, pressure vessels, hydraulic systems, etc., as applicable
4	A	Materials and welding details
5	A	Foundations and fastening of the equipment to the ship structures
(1) A = to be submitted for approval in four copies I = to be submitted for information in duplicate		

2 Arrangements for cable laying, hauling and repair

2.1 Typical machinery and equipment of cable laying units

2.1.1 (1/1/2022)

Cable laying units, in relation to the special service to be performed, are generally to be provided with the following machinery and equipment:

- a) a main windlass for cable hauling or laying, which generally consists of a drum with a horizontal axis (the surface of which is formed by a series of timed conveyors which fleet the cable axially across the face of the drum) housing the repeaters fitted throughout the cable length without damaging them (see Fig 1 (a))
- b) a linear tensioner working in conjunction with the main windlass and fitted between it and the cable tank, which maintains the due tension of the cable in relation to the cable type so as to allow effective cable hauling or laying. In order to permit the passage of repeaters, the tensioner may be of the type having either a series of double opposed rubber tyres (see Fig 1 (b)) or pressure-compensated opposed tracks (see Fig 1 (c)).
- c) a dynamometer, normally fitted between the main windlass and the bow and stern sheaves, which continuously measures the force required to displace the cable under tension
- d) one or more cable transporters, used to move the cable from the tank(s) and the tensioner.

All the above machinery and equipment form the "cable laying or hauling line". More than one line may be fitted on board in the case of special service requirements.

2.2 Design of cable handling machinery and equipment

2.2.1 In general, the scantlings of components of machinery and equipment listed in [2.1] and, more generally, of any other machinery and/or equipment to be used for the laying, hauling or repair of submarine cables are not the subject of specific requirements for class. However, such machinery and equipment are to be designed taking into account the necessary mechanical structural strength with selection of materials appropriate for the intended use based on loads supplied by the Manufacturer.

2.3 Safety

2.3.1 The requirements of this Chapter are based on the assumption that during cable handling all necessary safety measures are taken, due consideration being given to risks connected with the use of machinery and equipment dealt with in [2.1], and that such machinery and equipment are properly used by skilled personnel.

2.4 Testing of cable handling machinery and equipment

2.4.1 General

Machinery covered by [2.1] is to be tested in compliance with the following requirements, with the exception of prime movers and "hydraulic accumulator" type pressure vessels, which are to be tested in compliance with the applicable requirements of the various Sections of the Rules.

Figure 1 : Cable handling machinery

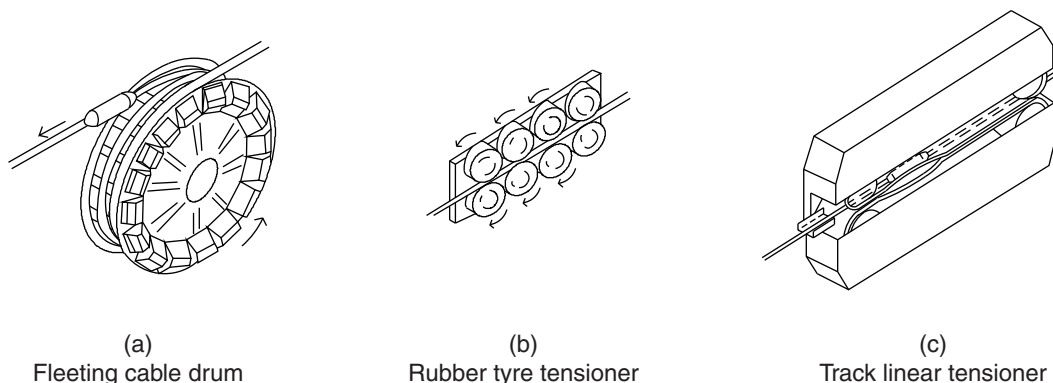

2.4.2 Testing of materials and components of the machinery

- In general, testing is required for materials intended for shafts, gearing, pressure parts of pumps and hydraulic motors, and plates of foundations of welded construction.
- As far as mechanical tests of materials are concerned, internal shop testing certificates submitted by the Manufacturer may be accepted by the Society at its discretion; in such cases, testing operations witnessed by the Surveyor may be limited to visual external inspection associated, where necessary, with non-destructive examinations and hardness tests.

2.4.3 Hydrostatic tests

Pressure parts are to be subjected to hydrostatic tests in accordance with the applicable requirements.

2.4.4 Tests on electrical components

The tests required in Part C, Chapter 2 are to be carried out as applicable.

2.4.5 Running tests

- Running tests of each individual piece of equipment are to be carried out whenever possible at the Manufacturer's works; as an alternative, the above tests may be performed on board during the trials required after installation of machinery.
- During the running tests, the suitability of all the arrangements concerned is to be checked in relation to the various expected service conditions.
- On completion and subject to the result of the above tests, the inspection of components may be required, with dismantling where deemed necessary by the Surveyor in charge of the testing.

3 On board trials

3.1 Ship trials

3.1.1

- Upon completion of construction, in addition to conventional sea trials, specific tests may be required at the Society's discretion in relation to the particular service for which the ship is intended or the particular characteristics of machinery and equipment fitted on board.
- In particular, as far as propulsion and steering systems are concerned, tests may be required to check the manoeuvring capability and the speed of the ship whilst operating with only directional propellers or active rudders or a combination thereof.
- In the case of ships mainly intended for repair of submarine cables, a check of manoeuvring capability whilst running astern or a complete overturning trial may be required to be carried out using the rudder, active rudders or side thrusters only.
- In the case of ships provided with a dynamic positioning system, tests to check the capability of holding the desired position or heading are requested.

3.2 Equipment trials

3.2.1

- As far as arrangements for the cable laying, hauling and/or repair lines are concerned, tests are to be carried out to verify the proper operation of all relevant machinery and equipment, by means of the actual hauling and laying of submarine cables, plain or with repeaters, at different ship speeds and, if necessary, in different sea and weather conditions.
- Special attention is to be paid during such tests so as to prevent cables being forced to reach their minimum allowed bending radius, both inside and outside the ship.

NON-PROPELLED UNITS

- SECTION 1 GENERAL**
- SECTION 2 HULL AND STABILITY**
- SECTION 3 MACHINERY SYSTEMS**
- SECTION 4 ADDITIONAL REQUIREMENTS FOR MACHINERY AND CARGO
SYSTEMS OF BARGE-OIL**
- SECTION 5 ADDITIONAL REQUIREMENTS FOR MACHINERY AND CARGO
SYSTEMS OF BARGE-LIQUEFIED GAS**
- SECTION 6 ADDITIONAL REQUIREMENTS FOR MACHINERY AND CARGO
SYSTEMS OF BARGE-LNG BUNKER**
- SECTION 7 ADDITIONAL REQUIREMENTS FOR MACHINERY AND CARGO
SYSTEMS OF BARGE-CHEMICAL**
- SECTION 8 ELECTRICAL INSTALLATIONS**

SECTION 1 GENERAL

1 General

1.1 Application

1.1.1 (1/9/2022)

Ships complying with the requirements of this Chapter are eligible for the assignment of one of the following service notations applicable to non-propelled units, as defined in Pt A, Ch 1, Sec 2, [4.9]:

- **barge** with the additional service features:
 - general cargo
 - oil
 - liquefied gas
 - LNG bunker
 - chemical
 - tug combined
 - accommodation
 - equipped for carriage of containers
- **pontoon** with the additional service features:
 - crane
 - equipped for carriage of containers

The service notation **barge-oil** may be completed by the additional service feature **flash point > 60°C**, where the unit carries only oil with flash point exceeding 60°C.

1.1.2 (1/5/2013)

Ships dealt with in this Chapter are to comply with the requirements stipulated in Parts A, B, C and D, as applicable taking into account the exemptions given in the different Sections of this Chapter, and with the requirements of this Chapter, which are specific to non-propelled units.

1.1.3 (1/6/2021)

Barge-general cargo are to comply with the requirements in this Chapter for barge that are not specific to barge with other additional service features.

1.1.4 (1/6/2021)

Barge-liquefied gas and **barge-LNG bunker** are to comply with the requirements of the latest version of the International Code for the Construction and Equipment of Ships Carrying Liquefied Gases in Bulk (IGC Code), as amended, as specified in Ch 9, [1.1.1] and [1.1.2].

1.1.5 (1/6/2021)

Barge-chemical are to comply with the requirements of the latest version of the International Code for the Construction and Equipment of Ships Carrying Dangerous Chemicals in

Bulk (IBC Code), as amended, as specified in Ch 8 [1.1.1] to [1.1.3].

The requirements in this chapter applicable to barge-chemical apply to units intended to carry products listed in the table in Chapter 17 of the IBC Code. For the carriage of products listed in the table in Chapter 18 of the IBC Code and products not at present listed in either of the tables in Chapter 17 or Chapter 18 of the IBC Code, the Society reserves the right to establish specific requirements.

1.1.6 (1/9/2022)

Barge-equipped for carriage of containers and **pontoon-equipped for carriage of containers** are to have fixed arrangements in compliance with the applicable requirements in Part E, Chapter 2.

1.2 Summary table

1.2.1 Tab 1 indicates, for ready reference, the Sections of this Chapter containing specific requirements applicable to non-propelled units.

Table 1 (1/6/2021)

Main subject	Reference
Ship arrangement	(1)
Hull and Stability	Sec 2
Machinery Systems	Sec 3
Additional Requirements for Machinery and Cargo Systems of Barge-Oil	Sec 4
Additional Requirements for Machinery and Cargo Systems of Barge-Liquefied Gas	Sec 5
Additional Requirements for Machinery and Cargo Systems of Barge-LNG Bunker	Sec 6
Additional Requirements for Machinery and Cargo Systems of Barge-Chemical	Sec 7
Electrical Installations	Sec 8
Automation	(1)
Fire protection, detection and extinction	(1)
(1) No specific requirements for non-propelled units are given in this Chapter.	

SECTION 2

HULL AND STABILITY

Symbols

- L_G : Ship's length, in m, measured at the maximum load waterline
- s : Spacing, in m, of ordinary stiffeners.

1 General

1.1 Application

1.1.1 General (1/6/2021)

Unless otherwise specified, the requirements of this Section apply to ships with one of the service notations **barge**, **pontoon** and **pontoon - crane**.

Specific requirements which apply only to ships with the service notation **barge** or ships with the service notation **pontoon** or **pontoon - crane** are indicated.

Barges with the additional service feature **tug combined** are also to comply with the applicable additional requirements in Ch 14, Sec 3.

Intact stability additional requirements for units with service notations **barge-oil**, **barge-accommodation**, **barge-liquified gas**, **barge-LNG bulker** and **barge-chemical**, are indicated in [2.3] to [2.6] respectively.

1.1.2 Main characteristics of non-propelled units

The requirements of this Section are based on the following assumptions, relevant to the main characteristics of non-propelled units:

- the structural configuration and proportions of non-propelled units are similar to those of propelled ships
- the cargo is homogeneously distributed.

The scantlings of non-propelled units with unusual shapes and dimensional proportions or carrying cargoes which are not homogeneously distributed, such as containers or heavy loads concentrated in limited areas, are to be considered by the Society on a case-by-case basis, taking into account the results of direct calculations, to be carried out according to Pt B, Ch 7, App 1.

2 Stability

2.1 Intact stability for ships with service notation “barge”, “pontoon” or “pontoon-crane”

2.1.1 Application (1/7/2012)

The requirements of this item [2.1] apply to seagoing ships with one of the service notations **barge**, **pontoon** and **pontoon-crane** with the following characteristics:

- a) unmanned
- b) having a block coefficient not less than 0,9
- c) having a breadth/depth ratio greater than 3,0
- d) having no hatchways in the deck except small manholes closed with gasketed covers.

The requirements of item [2.1] also apply to barges that do not comply with d).

The intact stability of ships not having any one of the above characteristics is to comply with Pt B, Ch 3, Sec 2, unless otherwise decided by the Society, on a case by case basis, taking into account the ship's characteristics. In this case, an appropriate entry is made in the classification files of the ship.

Items [2.1.2] and [2.1.3] do not apply to barges.

2.1.2 Trim and stability booklet

In addition to the information to be included in the trim and stability booklet specified in *Pt B, Ch 3, App 2, [1.1]*, simplified stability guidance, such as a loading diagram, is to be submitted to the Society for approval, so that pontoons may be loaded in compliance with the stability criteria.

2.1.3 Stability calculations

Stability calculations may be carried out according to the following criteria:

- no account is to be taken of the buoyancy of deck cargo (except buoyancy credit for adequately secured timber)
- consideration is to be given to such factors as water absorption (e.g. timber), trapped water in cargo (e.g. pipes) and ice accretion
- in carrying out wind heel calculations:
 - the wind pressure is to be constant and for general operations considered to act on a solid mass extending over the length of the deck and to an assumed height above the deck
 - the centre of gravity of the cargo is to be assumed at a point mid-height of the cargo
 - the wind lever arm is to be taken from the centre of the deck cargo to a point at one half the draught
- calculations are to be carried out covering the full range of operating draughts
- the downflooding angle is to be taken as the angle at which an opening through which progressive flooding may take place is immersed. This would not be an opening closed by a watertight manhole cover or a vent fitted with an automatic closure.

2.1.4 Intact stability criteria

The following intact stability criteria are to be complied with, for the loading conditions specified in *Pt B, Ch 3, App 2, [1.2.1]* and *Pt B, Ch 3, App 2, [1.2.2]*:

- the area under the righting lever curve up to the angle of maximum righting lever is to be not less than 0,08 mrad
- the static angle of heel due to a uniformly distributed wind load of 0,54 kPa (wind speed 30 m/s) may not exceed a heeling angle corresponding to half the freeboard for the relevant loading condition, where the lever of wind heeling moment is measured from the centroid of the windage area to half the draught
- The minimum range of stability is to be:
 - 20° for $L < 100$ m
 - 20° - 0,1° ($L - 100$) for $100 \leq L \leq 150$ m
 - 15° for $L > 150$ m.

2.2 Additional intact stability criteria for ships with service notation “pontoon - crane”

2.2.1 Application

The requirements of this item apply to ships with the service notation **pontoon - crane** and specify the criteria these ships are to satisfy during cargo lifting in addition to those in [2.1].

2.2.2 Intact stability criteria during cargo lifting (1/7/2003)

The following intact stability criteria are to be complied with:

- $\theta_C \leq 15^\circ$
- $GZ_C \leq 0,6 GZ_{MAX}$
- $A_1 \geq 0,4 A_{TOT}$

where:

θ_C : Heeling angle of equilibrium, corresponding to the first intersection between heeling and righting arms (see Fig 1)

GZ_C, GZ_{MAX} : Defined in Fig 1

A_1 : Area, in mrad, contained between the righting lever and the heeling arm curves, measured

from the heeling angle θ_C to the heeling angle equal to the lesser of:

- heeling angle θ_R of loss of stability, corresponding to the second intersection between heeling and righting arms (see Fig 1)
- heeling angle θ_F , corresponding to flooding of unprotected openings as defined in Pt F, Ch 13, Sec 11, [2.1.4] (see Fig 1)

A_{TOT} : Total area, in mrad, below the righting lever curve.

In the above formula, the heeling arm, corresponding to the cargo lifting, is to be obtained, in m, from the following formula:

$$b = \frac{Pd - Zz}{\Delta}$$

where:

P : Cargo lifting mass, in t

d : Transversal distance, in m, of lifting cargo to the longitudinal plane (see Fig 1)

Z : Mass, in t, of ballast used for righting the pontoon, if applicable (see Fig 1)

z : Transversal distance, in m, of the centre of gravity of Z to the longitudinal plane (see Fig 1)

Δ : Displacement, in t, at the loading condition considered.

The above check is to be carried out considering the most unfavourable situations of cargo lifting combined with the lesser initial metacentric height GM, corrected according to the requirements in Pt B, Ch 3, Sec 2, [4].

The residual freeboard of the unit during lifting operations in the most unfavourable stability condition is to be not less than 0,30 m. However, the heeling of the unit is not to produce in the lifting devices higher loads than those envisaged by the Manufacturer, generally expected to be 5° in the boom plane and 2° transversally in the case of a crane.

The vertical position of the centre of gravity of cargo lifting is to be assumed in correspondence of the suspension point.

Figure 1 : Cargo lifting

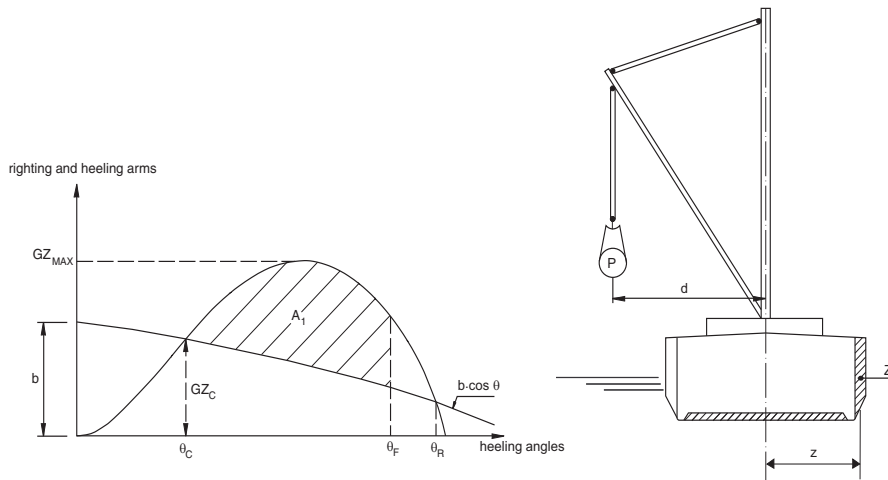

2.2.3 Intact stability criteria in the event of sudden loss of cargo during lifting (1/7/2003)

This additional requirement is compulsory when counterweights or ballasting of the ship are necessary or when deemed necessary by the Society taking into account the ship dimensions and the weights lifted.

The case of a hypothetical loss of cargo during lifting due to a break of the lifting cable is to be considered.

In this case, the following intact stability criteria are to be complied with:

- $\frac{A_2}{A_1} \geq 1$
- $\theta_2 - \theta_3 \geq 20^\circ$

where:

- A_1 : Area, in m.rad, contained between the righting lever and the heeling arm curves, measured from the heeling angle θ_1 to the heeling angle θ_C (see Fig 3),
- A_2 : Area, in m.rad, contained between the righting lever and the heeling arm curves, measured from the heeling angle θ_C to the heeling angle θ_2 (see Fig 3)
- A_3 : Area, in m.rad, contained between the righting lever and the heeling arm curves, measured from the heeling angle θ_C to the heeling angle θ_3 (see Fig 3)
- θ_1 : Heeling angle of equilibrium during lifting (see Fig 3)
- θ_2 : Heeling angle corresponding to the lesser of θ_R and θ_F
- θ_C : Heeling angle of equilibrium, corresponding to the first intersection between heeling and righting arms (see Fig 3)
- θ_3 : Maximum heeling angle due to roll, at which $A_3 = A_1$, to be taken not greater than 30° (angle in correspondence of which the loaded cargo on deck is assumed to shift (see Fig 3)

- θ_R : Heeling angle of loss of stability, corresponding to the second intersection between heeling and righting arms (see Fig 3).
- θ_F : Heeling angle at which progressive flooding may occur (see Fig 3)

In the above formulae, the heeling arm, induced on the ship by the cargo loss, is to be obtained, in m, from the following formula:

$$b = \frac{Zz}{\Delta} \cos \theta$$

where Z, z and Δ are defined in [2.2.2].

2.3 Additional intact stability criteria for ships with service notation "barge-oil"

2.3.1 General (1/5/2013)

The stability of the ship for the loading conditions in Pt B, Ch 3, App 2, [1.2.6] is to be in compliance with the requirements in Pt B, Ch 3, Sec 2. In addition, the requirements in [2.3.2] are to be complied with.

2.3.2 Liquid transfer operations (1/5/2013)

Ships with certain internal subdivision may be subjected to lolling during liquid transfer operations such as loading, unloading or ballasting. In order to prevent the effect of lolling, the design of barges of 5000 t deadweight and above is to be such that the following criteria are complied with:

- a) The intact stability criteria reported in b) is to be complied with for the worst possible condition of loading and ballasting as defined in c), consistent with good operational practice, including the intermediate stages of liquid transfer operations. Under all conditions the ballast tanks are to be assumed slack.
- b) The initial metacentric height GMo, in m, corrected for free surface measured at 0° heel, is to be not less than 0,15. For the purpose of calculating GMo, liquid surface corrections are to be based on the appropriate upright free surface inertia moment.

c) The vessel is to be loaded with:

- all cargo tanks filled to a level corresponding to the maximum combined total of vertical moment of volume plus free surface inertia moment at 0° heel, for each individual tank
- cargo density corresponding to the available cargo deadweight at the displacement at which transverse KM reaches a minimum value
- full departure consumable
- 1% of the total water ballast capacity. The maximum free surface moment is to be assumed in all ballast tanks.

2.4 Additional intact stability criteria for units with service notation "barge - accommodation"

2.4.1 Application (1/7/2014)

In addition to the requirements of [2.1], the requirements of this item [2.4] apply to ship units with the service notation **barge - accommodation**.

2.4.2 Righting moment and heeling moment curves (1/7/2014)

a) Curves of righting moments and of wind heeling moments similar to Fig 3 with supporting calculations are to be prepared covering the full range of operating draughts.

The righting moment curves and wind heeling moment curves are to be related to the most critical axes.

Account is to be taken of the free surface of liquid in tanks.

Where equipment is of such a nature that it can be lowered and stowed, additional wind heeling moment curves may be required and such data are to clearly indicate the position of such equipment.

b) The curves of wind heeling moments are to be drawn for wind forces calculated by the following formula:

$$F = 0,5 C_s \cdot C_H \cdot r \cdot V^2 \cdot A$$

where:

- F : the wind force, in N
- C_s : the shape coefficient depending on the shape of the structural member exposed to the wind (see Tab 1);
- C_H : the height coefficient depending on the height above sea level of the structural member exposed to the wind (see Tab 2);
- r : the air mass density (1,222 kg/m³)
- V : the wind velocity, in m/s;
- A : the projected area of all exposed surfaces in either the upright or the heeled condition, in m².

Shapes or combinations of shapes which do not readily fall into the specified categories will be subject to special consideration by the Society.

Realistic operating conditions are to be evaluated as follows:

- 1) The unit is to be capable of remaining in the operating mode with a sustained wind velocity of not less than 36 m/s (70 knots).
- 2) The capability of remaining in safe condition during a severe storm condition, with a sustained wind velocity of not less than 51,5 m/s (100 knots), in a reasonable period of time for the particular unit.
- 3) In all cases, the limiting wind velocities are to be specified and instructions are to be included in the Stability booklet for changing the mode of operation by redistribution of the variable load and equipment, by changing draughts, or both.
- 4) Consideration may be given to a reduced sustained wind velocity of not less than 25,8 m/s (50 knots). Particulars of the applicable service restrictions are to be recorded in the stability booklet. For the purpose of calculation, it is to be assumed that the unit is floating free of mooring restraints.

In calculating the projected areas to the vertical plane, the area of surfaces exposed to wind due to heel or trim, such as under-deck surfaces, etc., is to be included using the appropriate shape factor.

An appropriate shape coefficient is to be taken from Tab 1.

In calculating the wind forces, the following procedures are recommended:

- in the case of units with columns, the projected areas of all columns are to be included; i.e. no shielding allowance is to be taken;
- the block projected area of a clustering of deckhouses may be used in lieu of the calculation of each individual area. The shape coefficient may be assumed to be 1,1;
- isolated houses, structural shapes, cranes, etc. are to be calculated individually, using the appropriate shape coefficient.

c) In calculating the wind heeling moments, the lever of the wind overturning force is to be taken vertically from the centre of pressure of all surfaces exposed to the wind to the centre of lateral resistance or, if available, the centre of hydrodynamic pressure, of the underwater body of the unit.

The unit is to be assumed floating free of mooring restraints.

However, the possible detrimental effects of mooring restraints are to be considered.

d) The wind heeling moment curve is to be calculated for a sufficient number of heel angles to define the curve. For unit shaped hulls, the curve may be assumed to vary as the cosine function of unit heel.

Table 1 : Values of the shape coefficient C_s (1/7/2014)

Shape	C_s
Spherical	0,4
Cylindrical	0,5
Large flat surfaces (hull, deckhouse, smooth under-deck areas)	1,0
Drilling derrick	1,25
Wires	1,2
Exposed beams and girders under deck	1,3
Small parts	1,4
Isolated shapes (crane, beam, etc.)	1,5
Clustered deckhouses or similar structures	1,1

Table 2 : Values of the height coefficient C_H (1/7/2014)

Height above sea level (m)	C_H
0 - 15,3	1,00
15,3 - 30,5	1,10
30,5 - 46,0	1,20
46,0 - 61,0	1,30
61,0 - 76,0	1,37
76,0 - 91,5	1,43
91,5 - 106,5	1,48
106,5 - 122,0	1,52
122,0 - 137,0	1,56
137,0 - 152,5	1,60
152,5 - 167,5	1,63
167,5 - 183,0	1,67
183,0 - 198,0	1,70
198,0 - 213,5	1,72
213,5 - 228,5	1,75
228,5 - 244,0	1,77
244,0 - 256,0	1,79
above 256	1,80

2.4.3 Intact stability (1/7/2014)

a) The stability of a unit is to meet the following criteria (see also Fig 2).

- 1) For all units, the area under the righting moment curve to the second intercept or downflooding angle, whichever is less, is to be not less than 40% in excess of the area under the wind heeling moment curve to the same limiting angle.

2) The righting moment curve is to be positive over the entire range of angles from upright to the second intercept.

3) A check is to be carried out to ensure that the lesser of the downflooding angle and the second intercept angle is not greater than the following angles:

- the angle for which the stresses of whichever primary structural element become excessive;
- the limit angle for which lashes of loads on the decks are calculated.

b) Each unit is to be capable of attaining a severe storm condition in a period of time consistent with the meteorological conditions. The procedures recommended and the approximate length of time required, are to be contained in the stability booklet.

It is to be possible to achieve the severe storm condition without the removal or relocation of solid consumables or other variable load. However, the Society may permit relaxations in a geographic location where weather conditions annually or seasonally do not become sufficiently severe to require a unit to go to severe storm condition.

The geographic locations, weather conditions and loading conditions in which this is permitted are to be identified in the stability booklet.

c) Alternative stability criteria may be considered by the Society provided an equivalent level of safety is maintained and if they are demonstrated to afford adequate positive initial stability. In determining the acceptability of such criteria, the Society may consider at least the following and take into account as appropriate:

- 1) environmental conditions representing realistic winds (including gusts) and waves appropriate for worldwide service in various modes of operation;
- 2) dynamic response of a unit. Analysis is to include the results of wind tunnel tests, wave tank model tests and non-linear simulation, where appropriate. Any wind and wave spectra used is to cover sufficient frequency ranges to ensure that critical motion responses are obtained;
- 3) potential for flooding taking into account dynamic responses and wave profile in a seaway;
- 4) susceptibility to capsizing considering the unit's restoration energy and the static inclination due to the mean wind speed and the maximum dynamic response;
- 5) an adequate safety margin to account for uncertainties.

2.4.4 Intact stability for units to be moored in sheltered waters (1/7/2014)

The initial metacentric height GM_0 , duly corrected for free surfaces effects of liquids, see Pt B, Ch 3, Sec 2, [4], is to result not less than 0,35 m in any expected operating condition.

2.5 Additional intact stability criteria for units with service notation "barge - liquefied gas" and "barge - LNG bunker"

2.5.1 General (1/6/2021)

The stability of the ship for the loading conditions in Pt B, Ch 3, App 2, [1.2.8] is to be in compliance with the requirements in Pt B, Ch 3, Sec 2.

2.6 Additional intact stability criteria for units with service notation "barge - chemical"

2.6.1 General (1/6/2021)

The stability of the ship for the loading conditions in Pt B, Ch 3, App 2, [1.2.7] is to be in compliance with the requirements in Pt B, Ch 3, Sec 2.

Figure 2 : Righting moment and heeling moment curves (1/7/2014)

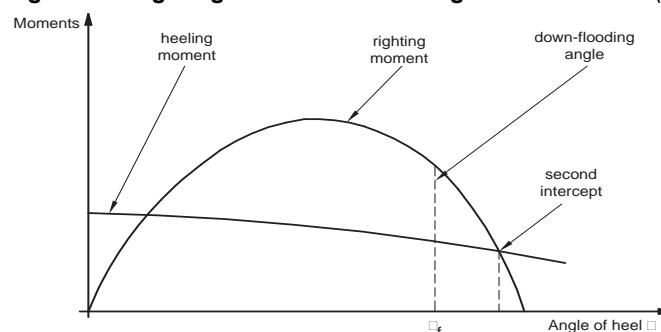

3.1.3 Truss arrangement supporting deck loads

Where truss arrangements are used as supports of the deck loads, including top and bottom girders in association with pillars and diagonal bracing, the diagonal members are generally to have angles of inclination with the horizontal of about 45° and cross-sectional area of about 50% that of the adjacent pillars.

3.2 Lifting appliances

3.2.1 Crane or derrick position during navigation

For ships with the service notation **pontoon - crane**, the crane boom or the derrick structure is to be lowered and efficiently secured to the pontoon during the voyage.

4 Hull girder strength

4.1 Yielding check

4.1.1 Small non-propelled units lifted by crane

For small non-propelled units intended to be lifted on board ship by crane, the hull girder strength is to be checked, in the condition of fully-loaded barge lifted by crane, through criteria to be agreed with the Society on a case-by-case basis.

In any case, in general, the normal stress σ and the shear stress τ induced in the hull girder when lifted by crane are to comply with the following formulae:

$$\leq \sigma 150/k \text{ N/mm}^2$$

3 Structure design principles

3.1 Hull structure

3.1.1 Framing of ships with one of the service notations "pontoon" and "pontoon - crane"

In general, ships with one of the service notations **pontoon** and **pontoon - crane** are to be longitudinally framed.

3.1.2 Supports for docked non-propelled units

Adequate supports are to be fitted on the longitudinal centreline in order to carry loads acting on the structure when the non-propelled units are in dry dock.

$$\tau \leq 100/k \text{ N/mm}^2.$$

Figure 3 : Cargo loss (1/7/2002)

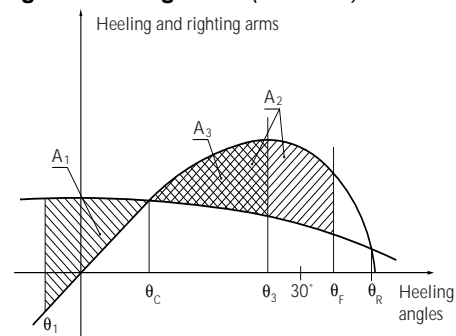

A_1 : Area between θ_1 and θ_c
 A_2 : Area between θ_c and θ_2 (in the figure $\theta_2 = \theta_f$)
 A_3 : Area between θ_c and θ_3
 $A_3 = A_1$

4.1.2 Ships with service notation "pontoon" carrying special cargoes

For ships with the service notation **pontoon** intended for the carriage of special cargoes, such as parts of offshore units, the hull girder strength is to be checked through criteria to be agreed with the Society on a case-by-case basis.

Moreover, where these ships are fitted with arrangements for launching the above structures, additional calculations are to be carried out in order to evaluate the stresses during the various stages of launching. The Society may accept stresses higher than those in [4.1.1], to be considered on a

case-by-case basis, taking into account favourable sea and weather conditions during launching.

4.1.3 Ships with service notation “pontoon - crane”

For ships with the service notation **pontoon - crane** having length greater than 65 m, the hull girder strength is to be checked when the lifting appliance, such as a crane or derrick, is operated, taking into account the various loading conditions considered, through criteria to be agreed with the Society on a case-by-case basis.

5 Hull scantlings

5.1 General

5.1.1 Minimum net thicknesses of ships with service notation “barge” carrying liquids

For ships with the service notation **barge** carrying liquid cargo inside tanks, the net thicknesses of cargo tank platings are to be not less than the values given in Tab 3.

For other structures or transverse bulkheads not forming boundaries of cargo tanks, the above minimum thicknesses may be reduced by 1 mm.

In pump rooms, the net thicknesses of plating of exposed decks, longitudinal bulkheads and associated ordinary stiffeners and primary supporting members are to be not less than the values given in Tab 3.

5.1.2 Minimum net thicknesses of decks forming tank top

Where the decks of non-propelled units form a tank top, the minimum net thicknesses of plating are to be not less than those obtained from Tab 3.

5.1.3 Scantlings of plating, ordinary stiffeners and primary supporting members

Where no rudder is fitted, in applying the formulae in Part B, Chapter 7 or Part B, Chapter 8, as applicable, L need not exceed $0,97 L_G$.

5.1.4 Net thickness of strength deck plating

Within the cargo area, the net thickness of strength deck plating is to be increased by 1,5 mm with respect to that calculated according to Pt B, Ch 7, Sec 1 or Pt B, Ch 8, Sec 3, as applicable.

Table 3 : Minimum net thickness of plating

Plating	Minimum net thickness, in mm
Decks, sides, bottom, inner bottom, bulkheads, primary supporting members in the cargo area	<ul style="list-style-type: none"> • For $L \leq 45\text{m}$, the greater of: <ul style="list-style-type: none"> - $(4,1 + 0,060 L)k^{0,5}$ - $2,8 + 0,060 L$ • For $45\text{m} < L \leq 200\text{m}$, the greater of: <ul style="list-style-type: none"> - $(5,9 + 0,023 L)k^{0,5}$ - $4,5 + 0,023 L$ • For $L > 200\text{m}$, the greater of: <ul style="list-style-type: none"> - $(8,6 + 0,009 L)k^{0,5}$ - $7,2 + 0,009 L$
Weather deck, within cargo area outside 0,4 amid-ships	<ul style="list-style-type: none"> • For $L \leq 200\text{m}$, the greater of: <ul style="list-style-type: none"> - $11,3 s k^{0,5}$ - $11,3 s - 1,4$ • For $200\text{m} < L < 250\text{m}$, the greater of: <ul style="list-style-type: none"> - $(11,3 s + 0,026 (L - 200))k^{0,5}$ - $11,3 s + 0,026 s (L - 200) - 1,4$ • For $L \geq 250\text{m}$, the greater of: <ul style="list-style-type: none"> - $12,6 s k^{0,5}$ - $12,6 s - 1,4$
Plating of ordinary stiffeners and other structures of cargo tanks	<ul style="list-style-type: none"> • For $L \leq 45\text{m}$, the greater of: <ul style="list-style-type: none"> - $(4,1 + 0,060 L)k^{0,5}$ - $2,8 + 0,060 L$ • For $45\text{m} < L \leq 200\text{m}$, the greater of: <ul style="list-style-type: none"> - $(5,9 + 0,023 L)k^{0,5}$ - $4,5 + 0,023 L$ • For $L > 200\text{m}$, the greater of: <ul style="list-style-type: none"> - $10,0 k^{0,5}$ - $8,6$
Note 1:	
k : Material factor for steel, defined in Pt B, Ch 4, Sec 1, [2.3].	

5.2 Hull scantlings of non-propelled units with the service notation “pontoon” fitted with arrangements and systems for launching operations

5.2.1 Additional information (1/1/2015)

In addition to the documentation specified in Pt B, Ch 1, Sec 3, the following information is to be submitted to the Society for approval:

- maximum draught of the ship during the different stages of the launching operations
- maximum still water and inertial operating loads and their distribution in load out, towing and launching conditions
- launching cradle or grillage location.

The scantlings of the launching cradle or grillage and, if fitted, of the skid beams are to be submitted to the Society for information, in order to check that their loads are correctly transmitted to the deck structure.

5.2.2 Scantlings of plating, ordinary stiffeners and primary supporting members

In applying the formulae in Part B, Chapter 7 or Part B, Chapter 8, as applicable, T is to be taken equal to the maximum draught during the different stages of launching and taking into account, where appropriate, the differential static pressure.

5.2.3 Deck scantlings (1/1/2015)

The net scantlings of decks are to be in accordance with Part B, Chapter 7 or Part B, Chapter 8, considering the maximum loads acting on the launching cradle or grillage.

The net thickness of deck plating in way of launch ground ways is to be suitably increased if the cradle or grillage may be placed in different positions.

The scantlings of decks in way of pivoting and end areas of the cradle or grillage are to be obtained through direct calculations, to be carried out according to the criteria in Pt B, Ch 7, App 1.

5.2.4 Launching cradles or grillage (1/1/2015)

The launching cradles or grillage are to be adequately connected to deck structures and arranged, as far as possible, in way of longitudinal bulkheads or at least of girders.

5.3 Hull scantlings of non-propelled units with service notation "pontoon - crane"

5.3.1 Loads transmitted by the lifting appliances

The forces and moments transmitted by the lifting appliances to the ship's structures, during both lifting service and navigation, are to be obtained by means of criteria to be considered by the Society on a case-by-case basis.

5.3.2 Ship's structures

The ship's structures, subjected to the forces transmitted by the lifting appliances, are to be reinforced to the Society's satisfaction.

5.3.3 Lifting appliances

The check of the behaviour of the lifting appliances at sea is outside the scope of the classification and is under the responsibility of the Designer. However, where the requirements in [3.2.1] may not be complied with (i.e. sailing with boom or derrick up) or where, exceptionally, trips with suspended load are envisaged, the Designer is to submit the check of the lifting appliances during navigation to the Society for information.

The Society may check these calculations following a specific request, while also reserving the right to do so, when deemed necessary, without any such request.

6 Other structures

6.1 Reinforcement of the flat bottom forward area of ships with one of the service notations "pontoon" and "pontoon - crane"

6.1.1 Application (1/7/2024)

The requirements in this Article are applicable to barges, pontoons and barge-shaped assisted propelled units with a navigation notation other than sheltered area.

For barges, pontoons and barge-shaped assisted propelled units of less than 100 m in length, when a reduction of the speed is provided in relation with the sea state to avoid bottom impact pressure for flat bottom area, the requirements related to the bottom impact pressure are not applicable.

6.1.2 Area to be reinforced

The structures of the flat bottom forward area are to be able to sustain the dynamic pressure due to the bottom impact.

The flat bottom forward area is:

- longitudinally, over the bottom located from the fore end to 0,15 L aft of the fore end
- transversely, over the whole flat bottom, and the adjacent zones up to a height, from the base line, not less than 2L, in mm. In any case, this height need not be greater than 300 mm.

6.1.3 Bottom impact

The bottom dynamic impact pressure is to be considered if: $T_F < 0,04 L$,

where T_F is the minimum forward draught, in m, among those foreseen in operation in ballast conditions or conditions of partial loading.

If T_F is less than 0,025 L, strengthening of the flat bottom forward is to be considered by the Society on a case-by-case basis.

6.1.4 Partial safety factors

The partial safety factors to be considered for checking the reinforcements of the flat bottom forward area are specified in Tab 4.

Table 4 : Reinforcements of the flat bottom forward area - Partial safety factors

Partial safety factors covering uncertainties regarding:	Partial safety factors		
	Symbol	Plating	Ordinary stiffeners
Still water pressure	γ_{S2}	1,00	1,00
Wave pressure	γ_{W2}	1,10	1,10
Material	γ_m	1,02	1,02
Resistance	γ_R	1,30	1,15

6.1.5 Scantlings of plating and ordinary stiffeners

Where T_F is less than 0,03 L, the net scantlings of plating and ordinary stiffeners of the flat bottom forward area, as

defined in [6.1.2], are to be not less than those obtained according to Pt B, Ch 9, Sec 1, [2] and those obtained from Tab 5.

Where T_F is between 0,03 L and 0,04 L, the net scantlings of plating and ordinary stiffeners are to be obtained by linear interpolation between those obtained according to Pt B, Ch 9, Sec 1, [2] and those obtained from Tab 5.

6.1.6 Tapering

Outside the flat bottom forward area, scantlings are to be gradually tapered so as to reach the values required for the areas considered.

6.1.7 Floor spacing

In the area to be reinforced, defined in [6.1.2], the floor spacing is to be not greater than $0,68 L^{1/4}$.

7 Hull outfitting

7.1 Equipment

7.1.1 Manned non-propelled units

The equipment of anchors, chain cables and ropes to be fitted on board manned non-propelled units is to comply with Pt B, Ch 10, Sec 4, unless otherwise required by the Society.

Chain cables for anchors may be replaced by steel ropes having the same breaking load. The ropes are to be connected to the anchors by approximately 10 m of chain cable complying with Pt B, Ch 10, Sec 4.

Non-propelled units continuously assisted by a tug may have only one anchor, complying with Pt B, Ch 10, Sec 4,

and a chain rope having length neither less than 75% of the length obtained according to Pt B, Ch 10, Sec 4, nor less than 220 m.

7.1.2 Manned non-propelled units with navigation notation “sheltered area”

For non-propelled units with the navigation notation **sheltered area**, the equipment is not required for classification purposes.

However, in this case, the equipment to be fitted may be obtained from Pt B, Ch 10, Sec 4, based on the value of equipment number EN equal to 50% of that obtained from the applicable formulae in Pt B, Ch 10, Sec 4, [2].

7.1.3 Unmanned non-propelled units

For unmanned non-propelled units, the equipment is not required for classification purposes. The scantlings of anchors, chain cables and ropes to be fitted on board are the responsibility of the Designer.

7.1.4 Towing arrangements

Non-propelled units are to be fitted with suitable arrangements for towing, with scantlings under the responsibility of the Designer.

The Society may, at the specific request of the interested parties, check the above arrangements and the associated hull strengthening; to this end, the maximum pull for which the arrangements are to be checked is to be specified on the plans.

Table 5 : Reinforcements of plating and ordinary stiffeners of the flat bottom forward area

Element	Formula	Minimum value
Plating	Net thickness, in mm: $t = 13,9 C_a C_r S \sqrt{\gamma_R \gamma_m \frac{\gamma_{W2} P_{Bl}}{R_y}}$	Net minimum thickness, to be taken, in mm, not less than: $t = 0,03L + 5,5 - c_E$ nor than the lesser of: $t = 16$ $t = 6,3 (s - 0,228 L^{1/4}) + 0,063 L + 3,5$ where s is to be taken not less than $0,182 L^{1/4}$
Note 1:		
c_E	: coefficient, to be taken equal to: $c_E = 1$ for $L \leq 65$ m $c_E = 3 - L / 32,5$ for 65 m < $L < 90$ m $c_E = 0$ for $L \geq 90$ m	
C_p	: Ratio of the plastic section modulus to the elastic section modulus of the ordinary stiffeners with an attached shell plating, to be taken equal to 1,16 in the absence of more precise evaluation	
$\gamma_R, \gamma_m, \gamma_{S2}, \gamma_{W2}$: Partial safety factors, defined in Tab 4	
P_{Bl}	: Bottom dynamic impact pressure, defined in Pt B, Ch 9, Sec 1, [3.2].	

Element	Formula	Minimum value
Ordinary stiffeners	Net section modulus, in cm ³ , to be taken as the lesser of: $w = \gamma_R \gamma_m \beta_b \frac{\gamma_{W2} P_{Bl}}{16 C_P R_y} \left(1 - \frac{s}{2\ell}\right) s \ell^2 10^3$ $w = \gamma_R \gamma_m \beta_b \frac{\gamma_{S2} T}{6 R_y} s \ell^2 10^4$	Web net minimum thickness, in mm, to be not less than the lesser of: <ul style="list-style-type: none"> • $t = 1,5L_2^{1/3}$ • the thickness of the attached plating.
	Net shear sectional area, in cm ² : $A_{Sh} = 10 \gamma_R \gamma_m \beta_s \frac{\gamma_{W2} P_{Bl}}{R_y} \left(1 - \frac{s}{2\ell}\right) s \ell$	

Note 1:

C_E : coefficient, to be taken equal to:
 $C_E = 1$ for $L \leq 65$ m
 $C_E = 3 - L / 32,5$ for 65 m $< L < 90$ m
 $C_E = 0$ for $L \geq 90$ m
 C_P : Ratio of the plastic section modulus to the elastic section modulus of the ordinary stiffeners with an attached shell plating, to be taken equal to 1,16 in the absence of more precise evaluation
 $\gamma_R, \gamma_m, \gamma_{S2}, \gamma_{W2}$: Partial safety factors, defined in Tab 4
 P_{Bl} : Bottom dynamic impact pressure, defined in Pt B, Ch 9, Sec 1, [3.2].

8 Additional arrangement requirements for ships with service notation "Barge-oil"

8.1 Application

8.1.1 (1/5/2013)

The requirements of this item apply to ships with the service notation "barge-oil".

8.2 Cargo segregation

8.2.1 (1/5/2013)

Unless expressly provided otherwise, in ships enabled to carry cargoes having a flashpoint below 60°C, tanks containing cargo or cargo residues are to be placed forward of and segregated from accommodation, service and machinery spaces, drinking water and stores for human consumption by means of a cofferdam, a cargo pump room, a fuel oil tank, a ballast tank or any other similar compartment and arranged in such a way that a single failure of a deck or bulkhead will not permit the entry of gas or vapour from the cargo tank into control stations, accommodation and service spaces (see Fig 3 and Fig 4).

8.3 Size and arrangement of cargo tanks and slop tanks

8.3.1 Cargo tanks (1/5/2013)

Barge-oil of 600 t deadweight and above are not allowed to carry oil in any compartment extending forward of a collision bulkhead located in accordance with Pt B, Ch 2, Sec 1, [2].

Figure 4 (1/5/2013)

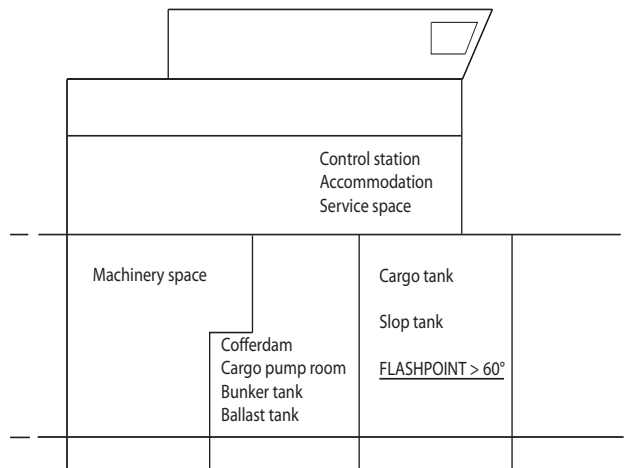
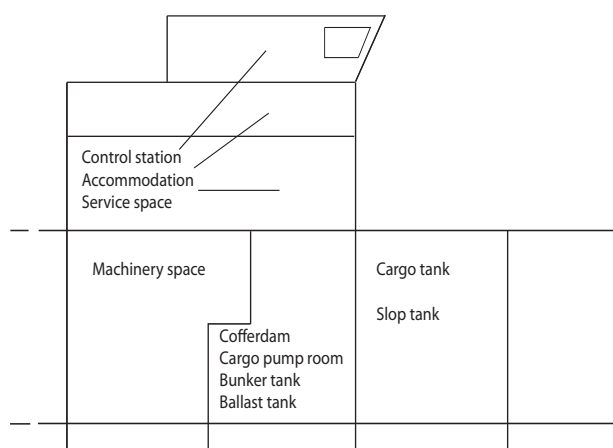

Figure 5 (1/5/2013)



8.3.2 Size and arrangement of cargo tanks (1/5/2013)

The length of each cargo tank is not to exceed 10 metres or one of the values of Tab 6, as applicable, whichever is the greater.

Table 6 : Length of cargo tanks (1/5/2013)

Longitudinal bulkhead arrangement	Cargo tank	Condition	Centreline bulkhead arrangement	Length of cargo tanks, in m
No bulkhead	-	-	-	$(0,5 b_i / B + 0,1) L$
Centreline bulkhead	-	-	-	$(0,25 b_i / B + 0,15) L$
Two or more bulkheads	Wing cargo tank	-	-	0,2 L
	Centre cargo tank	$b_i / B \geq 1/5$	-	0,2 L
		$b_i / B < 1/5$	No	$(0,5 b_i / B + 0,1) L$
			Yes	$(0,25 b_i / B + 0,15) L$

(1) b_i is the minimum distance from the ship side to the outer longitudinal bulkhead of the i-th tank, measured inboard at right angles to the centreline at the level corresponding to the assigned summer freeboard.
 (2) Not to exceed 0,2 L

8.3.3 Slop tanks (1/5/2013)

The arrangements of the slop tank or combination of slop tanks are to have a capacity necessary to retain the slop generated by tank washings, oil residues and dirty ballast residues. The total capacity of the slop tank or tanks is to be not less than 3 per cent of the oil carrying capacity of the ships, except that the Society may accept:

- 2% for such barge -oil where the tank washing arrangements are such that once the slop tank or tanks are charged with washing water, this water is sufficient for tank washing and, where applicable, for providing the driving fluid for ejectors, without the introduction of additional water into the system
- 2% where segregated ballast tanks are provided in accordance with [5]. This capacity may be further reduced to 1,5% for such barge -oil where the tank washing arrangements are such that once the slop tank or tanks are charged with washing water, this water is sufficient for tank washing and, where applicable, for providing the driving fluid for ejectors, without the introduction of additional water into the system.

- The society may accept slop tanks of any size, including absence of dedicated slop tanks, for units which:
 - are dedicated to the same type of cargo for many consecutive voyages, and
 - are arranged with segregated ballast tanks, and
 - do not carry out tank washing on a regular basis, and
 - retain on board (in cargo tanks) the total quantity of washing media, and discharge it ashore.

8.4 Access arrangement

8.4.1 (1/5/2013)

As far as practicable, permanent or movable means of access stored on board are to be provided to ensure proper survey and maintenance of cargo tanks and ballast compartments.

8.4.2 (1/5/2013)

Means of access to side and centre tanks may not be provided in the same transverse section.

8.4.3 (1/5/2013)

The pipe tunnel in the double bottom is to comply with the following requirements:

- it may not communicate with the engine room
- provision is to be made for at least two exits to the open deck arranged at a maximum distance from each other. One of these exits fitted with a watertight closure may lead to the cargo pump room.

8.4.4 Access to compartments in the cargo area (1/5/2013)

Access to cofferdams, ballast tanks, cargo tanks and other compartments in the cargo area is to be direct from the open deck and such as to ensure their complete inspection. Access to double bottom compartments may be through a cargo pump room, pump room, deep cofferdam, pipe tunnel or similar compartments, subject to consideration of ventilation aspects.

8.4.5 Access to the fore peak tank (1/5/2013)

The access to the fore peak tank is to be direct from the open deck.

Alternatively, indirect access from the open deck to the fore peak tank through an enclosed space may be accepted provided that:

- a) The unit is only enabled to carry products having a flashpoint exceeding 60°C, or
- b) The unit is enabled to carry products having any flashpoint and:
 - 1) the enclosed space is separated from the cargo tanks by cofferdams, the access is through a gas-tight bolted manhole located in the enclosed space and a warning sign is provided at the manhole stating that the fore peak tank may only be opened after:
 - it has been proven to be gas-free; or
 - any electrical equipment which is not electrically certified safe in the enclosed space is isolated or
 - 2) the enclosed space has a common boundary with the cargo tanks, is classified as hazardous area (see Note 1), the equipment inside is suitable for the hazardous area Zone 1 and the enclosed space can be well ventilated.

Note 1: The hazardous area classification is to be defined in accordance with IEC 60092-502: Electrical installations in ships - Tankers - Special features.

8.4.6 Access through horizontal openings (1/5/2013)

For access through horizontal openings the dimensions are to be sufficient to allow a person wearing a self-contained, air-breathing apparatus and protective equipment to ascend or descend any ladder without obstruction and also to provide a clear opening to facilitate the hoisting of an injured person from the bottom of the compartment. The minimum clear opening is to be not less than 600 mm by 600 mm..

8.4.7 Access through vertical openings (1/5/2013)

For access through vertical openings the minimum clear opening is to be not less than 600 mm by 800 mm at a

height of not more than 600 mm from the bottom shell plating unless gratings or other footholds are provided.

8.4.8 Barge-oil less than 5000 t deadweight (1/5/2013)

For barge-oil of less than 5000 t deadweight smaller dimensions may be approved by the Society in special circumstances, if the ability to traverse such openings or to remove an injured person can be proved to the satisfaction of the Society.

9 Mooring systems for units with the service notation "barge - accommodation"**9.1 Application****9.1.1 (1/7/2014)**

For units with the service notation barge - accommodation, the mooring system is to be in accordance with with the requirements in Pt F, Ch 13, Sec 21 for the assignment of the additional class notation **MOORING**.

10 Additional requirements for ships with service notation "Barge-liquefied gas"**10.1 Accommodation, service and machinery spaces and control stations****10.1.1 Precautions against hazardous vapours (1/6/2021)**

IGC CODE REFERENCE : Ch 3, 3.2.2

Compliance with the relevant requirements of the IGC Code, in particular with 3.2.4, 3.8, 8.2.10 and 12.1.6, as applicable, also ensures compliance with the requirements in IGC Code 3.2.2, relevant to precautions against hazardous vapours.

10.1.2 Air outlets (1/6/2021)

IGC CODE REFERENCE : Ch 3, 3.2.4

The requirements in IGC Code 3.2.4, relevant to air intakes, are also intended to be applicable to air outlets. This interpretation also applies to the requirements in IGC Code 3.8.4.

10.1.3 Doors facing cargo area (1/6/2021)

IGC CODE REFERENCE : Ch 3, 3.2.4

Doors facing the cargo area or located in prohibited zones in the sides are to be restricted to stores for cargo-related and safety equipment, cargo control stations as well as decontamination showers and eye wash.

Where such doors are permitted, the space may not give access to other spaces covered in IGC Code 3.2.4 and the common boundaries with these spaces are to be insulated with A60 class bulkheads.

10.1.4 Exemptions, ventilation openings and type of closures (1/6/2021)

IGC CODE REFERENCE : Ch 3, 3.2.6

The requirement for fitting air intakes and openings with closing devices operable from inside the space in ships intended to carry toxic products is to apply to spaces which are used for the ship's radio and main navigating equipment, cabins, mess rooms, toilets, hospitals, galleys, etc., but does not apply to spaces not normally manned such as engine room casings, steering gear compartments.

The closing devices are to give a reasonable degree of gas-tightness. Ordinary steel fire-flaps without gaskets/seals are normally not considered satisfactory.

10.1.5 Openings for removal of machinery (1/6/2021)

IGC CODE REFERENCE : Ch 3, 3.2.6

Bolted plates of A60 class for removal of machinery may be accepted on bulkheads facing cargo areas, provided sign-boards are fitted to warn that these plates may only be opened when the ship is in gas-free condition.

10.2 Access arrangement

10.2.1 Access to compartments in the cargo area (1/6/2021)

a) Passage through hatches and manholes

IGC CODE REFERENCE : Ch 3, 3.5

For the purpose of the requirements in IGC Code 3.5.3, the following applies:

- 1) The term "minimum clear opening of not less than 600 x 600 mm" means that such openings may have corner radii up to a maximum of 100 mm (see Fig 6).

Figure 6 : Minimum horizontal hatch size (1/6/2021)

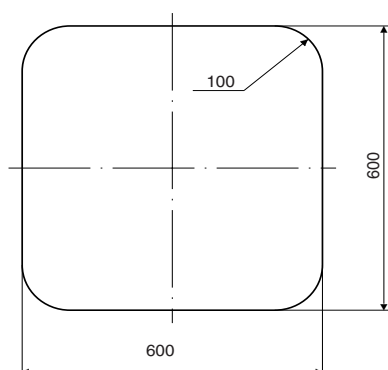

- 2) The term "minimum clear opening of not less than 600 x 800 mm" also includes an opening of the size specified in Fig 7:

Figure 7 : Minimum size of manholes (1/6/2021)

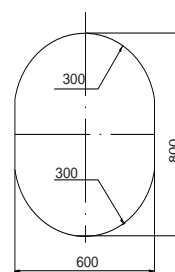

b) Cofferdams

IGC CODE REFERENCE : Ch 3, 3.5

Where fitted, cofferdams are to have sufficient size for easy access to all their parts. The width of the cofferdams may not be less than 600 mm.

c) Pipe tunnels

IGC CODE REFERENCE : Ch 3, 3.5

Pipe tunnels are to have enough space to permit inspection of pipes. The pipes in pipe tunnels are to be installed as high as possible from the ship's bottom.

d) Access to pipe tunnels

IGC CODE REFERENCE : Ch 3, 3.5

Access to pipe tunnels through manholes in the engine space is not permitted.

10.2.2 Access to the bow (1/6/2021)

a) This item [10.2.2] applies to ships subject to the International Load Line Convention 1966, as amended.

b) Liquefied gas carriers are to be provided either with a gangway between the superstructure or deckhouse aft and the forecastle, or with equivalent arrangements in accordance with the International Load Line Convention 1966, as amended.

c) *Liquefied gas carriers are to be provided with the means to enable the crew to gain safe access to the bow even in severe weather conditions. Such means are to be accepted by the Society.*

Note 1: The Society considers means in compliance with the Guidelines adopted by the Maritime Safety Committee of IMO with Resolution MSC.62(67) on 5/12/1996 as being acceptable.

10.3 Cargo containment

10.3.1 (1/6/2021)

The requirements of Ch 9, Sec 4 apply.

10.4 Materials for construction

10.4.1 (1/6/2021)

The requirements of Ch 9, Sec 6 apply.

11 Additional requirements for ships with service notation "Barge-LNG bunker"

11.1 Mooring and fendering

11.1.1 (1/6/2021)

Steel to steel contact between LNG bunker ship and receiving ship e.g. via mooring lines, ladders, gangways, chains for fender support etc. shall be avoided through the use of insulation. Bunker hoses/pipes shall be supported and isolated to prevent electrical contact with the receiving ship.

11.1.2 (1/6/2021)

The rubber fenders used for keeping the distance between the LNG bunkering ship and receiving ship shall be built according to an international recognized standard such as ISO 17357-2 or equivalent. The dimensions and arrangement of fenders shall be verified during risk assessment as required in [11.1.1] taking into consideration the interferences of the hazardous areas of both ships and the minimum bend radius of the bunkering hose.

11.2 Access arrangement

11.2.1 (1/6/2021)

The requirements of [10.2] apply.

11.3 Cargo containment

11.3.1 (1/6/2021)

The requirements of Ch 9, Sec 4 apply.

11.4 Materials for construction

11.4.1 (1/6/2021)

The requirements of Ch 9, Sec 6 apply.

12 Additional requirements for ships with service notation "Barge-chemical"

12.1 Accommodation, service and machinery spaces and control stations

12.1.1 Air intakes and other openings to accommodation spaces (1/6/2021)

IBC CODE REFERENCE : Ch 3, 3.2.2

The requirements relevant to air intakes in IBC Code 3.2.2 are also intended to be applicable to air outlets. This interpretation also applies to the requirements in IBC Code 3.2.3, 3.7.4, 8.3, 15.12.1.3 and 19.3.8.

12.1.2 Windows, sidescuttles and doors (1/6/2021)

IBC CODE REFERENCE : Ch 3, 3.2.3

- a) Access facing the cargo area or other prohibited zones is to be restricted to stores for cargo-related and safety equipment, cargo control stations and emergency shower spaces.
- b) Entrances and openings to service spaces located forward of the cargo area may not face such area. However, for small ships alternative arrangements may be specially considered by the Society.
- c) The bolt spacing for bolted plates mentioned in the paragraph in the reference is to be such as to guarantee a suitable gas-tightness.

12.1.3 Ships fitted with deckhouses originating from main deck (1/6/2021)

IBC CODE REFERENCE : Ch 3, 3.2.3

On all chemical tankers, regardless of the type of products to be carried, where a deckhouse is substituted for a superstructure and liquid products could flow along the sides of the house, the house front is to be continued to the sides of the ship in the form of a sill, or a permanent spillage barrier is to be arranged as described in Regulation II-2/56.6 of SOLAS 74(83).

12.2 Cargo tank arrangement

12.2.1 Location of cargo tanks (1/6/2021)

IBC CODE REFERENCE: Ch 2, 2.6

The requirements in IBC Code 2.6 apply to cargo tanks.

12.3 Access arrangement

12.3.1 Access to compartments in the cargo area (1/6/2021)

- a) Access to fuel oil tanks

IBC CODE REFERENCE : Ch 3, 3.4.1

The requirements in IBC Code 3.4.1 apply to fuel oil tanks adjacent to cargo tanks even if such fuel oil tanks are not included in the "cargo area" as defined in IBC Code 1.3.5.

- b) Accesses and escapes from double bottom tanks and similar spaces

IBC CODE REFERENCE : Ch 3, 3.4.1

To cater for restrictions in the movement of personnel and to limit the time needed for a possible emergency escape, two separate means of access are generally to be fitted in double bottom tanks and similar spaces where obstructions impede movement. The two accesses are to be as widely separated as practicable. Only one access may be approved in special circumstances if, it being understood that the escapes have the required dimensions, the ability to readily traverse the space and to remove an injured person can be proved to the satisfaction of the Society.

Figure 8 (1/6/2021)

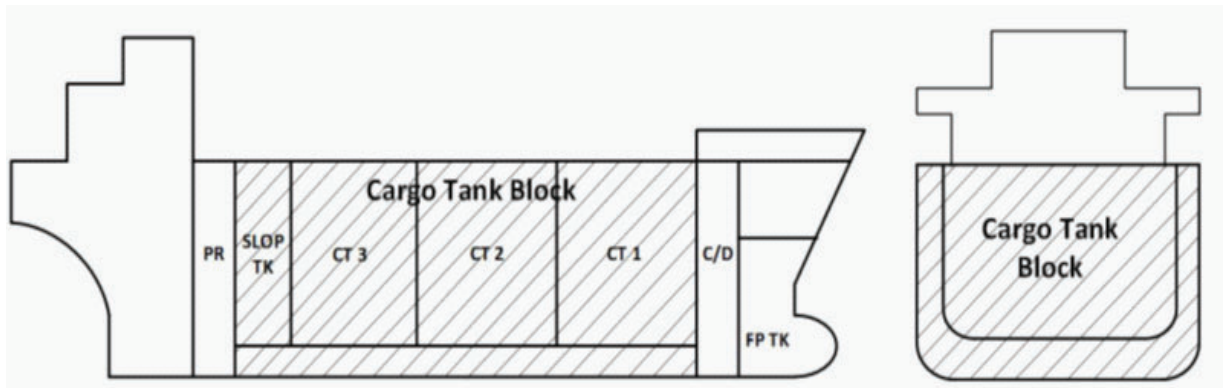

- c) Access through horizontal openings
 IBC CODE REFERENCE : Ch 3, 3.4.2
 The shape of the minimum acceptable clear opening of 600 mm by 600 mm is indicated in Fig 9.

Figure 9 : Shape of minimum acceptable clear opening of 600 mm by 600 mm (1/6/2021)

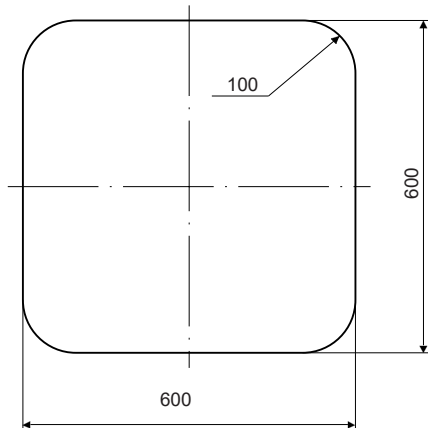

- d) Access through vertical openings
 IBC CODE REFERENCE : Ch 3, 3.4.3
 For pressure cargo tanks only, access openings may be circular openings having a diameter not less than 600 mm.
 The minimum size of vertical oval openings is defined in Fig 10.

Figure 10 : Minimum size of vertical oval openings (1/6/2021)

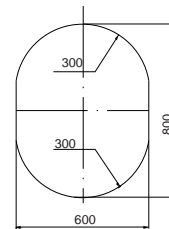

12.3.2 Access to the bow (1/6/2021)

- a) This item [12.3.2] applies to ships subject to the International Load Line Convention 1966, as amended.
- b) Chemical tankers are to be provided either with a gangway between the superstructure or deckhouse aft and the forecastle, or with equivalent arrangements in accordance with the International Load Line Convention 1966, as amended.
- c) *Chemical tankers are to be provided with the means to enable the crew to gain safe access to the bow even in severe weather conditions. Such means are to be accepted by the Society.*

Note 1: The Society considers means in compliance with the Guidelines adopted by the Maritime Safety Committee of IMO with Resolution MSC.62(67) on 5/12/1996 as being acceptable.

12.3.3 Access to pump rooms (1/6/2021)

IBC CODE REFERENCE : Ch 3, 3.3.1

In general, a cargo pump room is to be provided with one set of access/escape ladders. Where it is envisaged that personnel are normally employed in a pump room or the pump room is unusually large, an additional means of escape may be required.

12.3.4 Segregation of pump rooms (1/6/2021)

IBC CODE REFERENCE : Ch 3, 3.3.1

Cargo pump rooms and pump rooms may not give direct access to other ship spaces and are to be separated from adjacent spaces by means of gas-tight bulkheads and/or decks.

12.4 Coamings**12.4.1 (1/6/2021)**

IBC CODE REFERENCE : Ch 3, 3.7.7

In general, the height of the coaming is to be not less than 150 mm. In any case, it is to be not less than 50 mm above the upper edge of the sheerstrake.

12.5 Cargo containment**12.5.1 (1/6/2021)**

The requirements of Ch 8, Sec 4 apply.

12.6 Materials for construction**12.6.1 (1/6/2021)**

The requirements of Ch 8, Sec 6 apply.

12.7 Minimum distance of cargo tanks from shell**12.7.1 Exception (1/6/2021)**

Any cargo tank, irrespective of its location, may be used for collecting contaminated cargo pump room bilge water or tank washings, as an exception to the requirements in IBC Code 2.6.1.1.

12.7.2 Suction wells (1/6/2021)

In general, the area of suction wells is not to be greater than that required to accommodate cargo pumps, suction pipes, valves, heating coils etc., and to ensure efficient flow and the necessary access for cleaning and maintenance.

SECTION 3

MACHINERY SYSTEMS

1 General

1.1 Application

1.1.1 (1/6/2021)

This Section applies to non-propelled units.

Item [3] provides additional requirements that only apply to barges having the service notation barge-accommodation.

Sections 4 to 7 provide additional requirements that only apply to barges having the service notations **barge-oil**, **barge-liquified gas**, **barge-LNG bunker** and **barge-chemical**, respectively.

1.2 Documents to be submitted

1.2.1 (1/6/2021)

The documents listed in Tab 1 are to be submitted for approval for all barges.

1.3 Exemptions

1.3.1 (1/5/2013)

The requirements in Pt C, Ch 1, Sec 10, [11.4.1] b) do not apply to service tanks.

The requirements in Pt C, Ch 1, Sec 10, [11.4.6] a) do not apply.

2 Bilge system

2.1 Bilge system in ships having no source of electrical power

2.1.1 General (1/7/2011)

Where there is no source of electrical power on board, hand pumps are to be provided, in sufficient number and so positioned as to permit an adequate drainage of all the compartments of the ship.

The requirement to provide a bilge system and associated hand pumps may be waived in the case of vessels without persons on board.

2.1.2 Arrangement of the bilge system (1/7/2010)

The bilge system is to comply with one of the following arrangements:

- at least one pump is to be provided for each compartment
- at least two pumps connected to a bilge main are to be provided. The main is to have branch pipes allowing the draining of each compartment through at least one suction.

The spaces served only by hand pumps may be not provided with air pipes according to Pt C, Ch 1, Sec 10, [9.1]. In any event they are anyway to be provided with sounding means according to Pt C, Ch 1, Sec 10, [9.2].

2.1.3 Hand pumps

- Hand pumps are to be capable of being operated from positions above the load waterline and are to be readily accessible at any time.
- Hand pumps are to have a maximum suction height not exceeding 7,30 m.

2.1.4 Size of bilge pipes

- The internal diameter, in mm, of suction pipes is not to be less than the diameter given by the following formula:

$$d_1 = \frac{T}{100} + 50$$

where:

T : Underdeck tonnage, in tons.

- When the ship is subdivided into small watertight compartments, the diameter of these suctions need not exceed 50 mm.

2.2 Bilge system in ships having a source of electrical power

2.2.1 General

On board ships having no propelling machinery but having a source of electrical power, mechanical pumps are to be provided for draining the various compartments of the ship.

Cargo pumps may be used for this purpose.

2.2.2 Arrangement of the bilge system

The bilge system is to comply with the provisions of Pt C, Ch 1, Sec 10, [6.3] to Pt C, Ch 1, Sec 10, [6.6] applicable to the spaces concerned, except that direct suctions need not be provided.

2.2.3 Bilge pumps

The number and capacity of the bilge pumps are to comply with the relevant requirements of Pt C, Ch 1, Sec 10, [6.7].

2.2.4 Size of bilge pipes

The size of bilge pipes is to comply with the relevant requirements of Pt C, Ch 1, Sec 10, [6.8].

2.2.5 Unmanned barges and occasionally manned barges (1/1/2017)

The requirement to provide pumps and a bilge system suitable to drain water from each compartment may be waived in the case of vessels without persons on board, and in case of vessels intended to have persons on board only during specific operations at fixed location, with the presence of an assisting propelled ship in close proximity.

Even in these latest units, when the source of power is made of engines located within compartments having the bottom plating in any place extending below the deepest waterline,

these compartments are to be fitted with suctions from suitably located pumps operated by power.

The waiver to occasionally manned units may be granted only to such units showing satisfactory stability in the worse combination of loading and flooding of two adjacent compartments.

Table 1 : Documents to be submitted for all barges

No.	A/I (1)	Document (2)
1	A	Diagram of the bilge system
2	A	Diagram of the central priming system intended for the bilge pumps, where provided
3	A	Capacity, prime mover and location of the bilge pumps
<p>(1) A: To be submitted for approval in four copies I: To be submitted for information in duplicate</p> <p>(2) Diagrams are also to include, where applicable, the (local and remote) control and monitoring systems and automation systems.</p>		

3 Additional requirements for units with service notation "barge-accommodation"

3.1 Bilge system

3.1.1 General (1/6/2021)

- The bilge pumping system required in Pt C, Ch 1, Sec 10, [6] is to be capable of operation under all practicable conditions after a casualty, whether the unit is upright or listed. For this purpose, wing suctions is generally to be fitted except in narrow compartments at the end of the unit where one suction may be sufficient. In compartments of unusual form, additional suctions may be required.
- Arrangements are to be made whereby water in the compartment may find its way to the suction pipes.
- Where, for particular compartments, the Society is satisfied that the provisions of drainage may be undesirable, it may allow such provision to be dispensed with if damage stability calculations show that the survival capability of the unit will not be impaired.

3.1.2 Bilge pumps (1/7/2014)

- Number and capacity of bilge pumps

Any unit is to be provided with at least two power bilge pumps connected to the bilge main. For units with the service notation **barge-accommodation**, where the bilge pump numeral is 30 or more, one additional independent power pump is to be provided.

The bilge pump numeral is to be calculated as follows:

- where P_1 is greater than P :

$$\text{bilge pump numeral} = 72 \cdot \left[\frac{M + 2P_1}{V + P_1 - P} \right]$$

- in other cases:

$$\text{bilge pump numeral} = 72 \cdot \left[\frac{M + 2}{V} \right]$$

where:

- L : the length of the unit (m), as defined in the International Convention on Load Lines in force
- M : the volume of the machinery space (m³), that is below the bulkhead deck; with the addition thereto of the volume of any permanent oil fuel bunkers which may be situated above the inner bottom and forward of, or abaft, the machinery space. For the purpose of this item, machinery spaces are spaces between the watertight boundaries of a space containing the auxiliary machinery, including boilers and generators. In the case of unusual arrangements, the Administration may define the limits of the machinery spaces;
- P : the whole volume of the passenger and crew spaces below the bulkhead deck (m³), which are provided for the accommodation and use of passengers and crew, excluding baggage, store, provision and mail rooms;
- V : the whole volume of the unit below the bulkhead deck (m³);
- P_1 : NK where:
 - N : the number of passengers for which the ship is to be certified; and
 - K : 0,056 L

Each of the above pumps is to have a capacity not less than that required in Pt C, Ch 1, Sec 10, [6.7.4].

For use of ejectors in lieu of bilge pumps, see Pt C, Ch 1, Sec 10, [6.7.2].

- Location of bilge pumps

Where practicable, the power bilge pumps are to be placed in separate watertight compartments and so arranged or situated that these compartments will not be flooded by the same damage. If the auxiliary machinery and boilers are in two or more watertight compartments, the pumps available for bilge service are to be distributed as far as is possible throughout these compartments.

- Availability of pumps

On a unit of 91,5 m in length and upwards or having a bilge pump numeral of 30 or more, as stated in [3.1.2] a), the arrangements are to be such that at least one power bilge pump will be available for use in all flooding conditions which the unit is required to withstand, as follows:

- 1) one of the required bilge pumps is to be an emergency pump of a reliable submersible type having a source of power situated above the bulkhead deck, or
- 2) the bilge pumps and their sources of power are to be so distributed throughout the length of the unit that at least one pump in an undamaged compartment will be available.

d) Draining capability

With the exception of additional pumps which may be provided for peak compartments only, each required bilge pump is to be so arranged as to draw water from any space required to be drained.

3.1.3 Direct bilge suction (1/7/2014)

- a) In units subject to subdivision regulations, independent power bilge pumps situated in machinery and/or boiler spaces are to have direct suction from these spaces, except that not more than two such suction are to be required in any one space.
- b) Where two or more such suction are provided in one compartment, there is to be at least one on each side of the unit.
- c) The Society may require independent power bilge pumps situated in other spaces to have separate direct suction.

3.1.4 Control location (1/7/2014)

- a) The spindles of the sea inlet and direct suction valves are to extend well above the engine room platform.
- b) Where the pumps are driven by electric motors, their starting equipment are to be located at, or above, the level of the motors.

3.1.5 Provision against bilge system damage (1/7/2014)

a) Damage to the bilge system

Provision is to be made to prevent the compartment served by any bilge suction pipe being flooded in the event of the pipe being severed or otherwise damaged by collision or grounding in any other compartment. For this purpose, where the pipe is at any part situated nearer the side of the unit than one fifth of the breadth of the unit (measured at right angles to the centreline at the level of the deepest subdivision load line), or is in a duct keel, a non-return valve is to be fitted to the pipe in the compartment containing the open end.

b) Operation in the case of flooding

- 1) Distribution boxes, cocks and valves in connection with the bilge pumping system is to be so arranged

that, in the event of flooding, one of the bilge pumps may be operative on any compartment; in addition, damage to a pump or its pipe connecting to the bilge main outboard of a line drawn at one fifth of the breadth of the unit is to not put the bilge system out of action.

- 2) If there is only one system of pipes common to all the pumps, the necessary valves for controlling the bilge suction must be capable of being operated from above the bulkhead deck.
- 3) Where in addition to the main bilge pumping system an emergency bilge pumping system is provided, it is to be independent of the main system and so arranged that a pump is capable of operating on any compartment under flooding condition; in that case, only the valves necessary for the operation of the emergency system need be capable of being operated from above the bulkhead deck.

c) Valve controls

All cocks and valves referred in [3.1.5] b) which can be operated from above the bulkhead deck are to have their controls at their place of operation clearly marked and are to be provided with means to indicate whether they are open or closed.

3.1.6 Bilge system for small units (1/7/2014)

For units not subject to subdivision regulations, less than 25 tons gross tonnage, the bilge system will be specially considered by the Society in each single case.

3.2 Ballast system

3.2.1 (1/7/2014)

Water ballast should not in general be carried in tanks intended for fuel oil. In units in which it is not practicable to avoid putting water in fuel oil tanks, oily-water separating equipment to the satisfaction of the Society is to be fitted, or other alternative means, such as discharge to shore facilities are to be provided for disposing of the oily-water ballast.

3.3 Special requirements for starting arrangement of emergency generating sets

3.3.1 (1/7/2014)

The arrangements are to be such that the energy for the first charge of the sources of stored energy for starting the emergency generator can be produced on board under emergency condition, without external aid.

3.3.2 (1/7/2014)

The arrangements are to be such that the emergency generating set is automatically started periodically and kept running for a predetermined warm-up time. The interval between the starting and warm-up periods is not to exceed one month, and an alarm is to be given in case of failure of the starting attempts.

SECTION 4

ADDITIONAL REQUIREMENTS FOR MACHINERY AND CARGO SYSTEMS OF BARGE-OIL

1 General

1.1 Application

1.1.1 (1/6/2021)

These units are to comply with the requirements of Sec 3.

The requirements in this Section are additional to the ones in Sec 3.

Item [2] provides additional requirements that only apply to barges having the service notation barge-oil intended to carry oil having any flashpoint (i.e. including oils having flash point < 60°C).

Item [3] provides additional requirements that only apply to barges having the service notation barge-oil intended to carry only oil having flashpoint > 60°C.

Oil means petroleum in any form including crude oil, fuel oil, sludge, oil refuse and refined products (other than those petrochemicals listed in IBC Code Chapter 17).

1.2 Documents to be submitted

1.2.1 (1/6/2021)

The documents listed in Tab 1 are to be submitted for approval for barge oil intended to carry oil having any flashpoint.

The documents listed in Tab 1 are to be submitted for approval, for barge-oil intended to carry only oil having flashpoint > 60°C except for items 8 and 9.

1.3 Exemptions

1.3.1 (1/6/2021)

The requirements in Pt C, Ch 1, Sec 10, [11.4.1] b) do not apply to service tanks.

The requirements in Pt C, Ch 1, Sec 10, [11.4.6] a) do not apply.

2 Additional requirements for ships with service notation "barge-oil"

2.1 Piping systems other than cargo piping system

2.1.1 Materials (1/6/2021)

- a) Materials are to comply with the provisions of Pt C, Ch 1, Sec 10.
- b) Spheroidal graphite cast iron may be accepted for bilge and ballast piping.

2.1.2 Independence of piping systems (1/6/2021)

- a) Bilge, ballast and scupper systems serving spaces located within the cargo area:
 - are to be independent from any piping system serving spaces located outside the cargo area
 - are not to lead outside the cargo area.
- b) Fuel oil systems are to:
 - be independent from the cargo piping system
 - have no connections with pipelines serving cargo or slop tanks
 - bilge pumps serving spaces located within the cargo area are to be located in the cargo pump room or in another suitable space within the cargo area.

2.1.3 Passage through cargo tanks and slop tanks (1/6/2021)

- a) Unless otherwise specified, bilge, ballast and fuel oil systems serving spaces located outside the cargo area are not to pass through cargo tanks or slop tanks. They may pass through ballast tanks or void spaces located within the cargo area.
- b) Where expressly permitted, ballast pipes passing through cargo tanks are to fulfil the following provisions:
 - they are to have welded or heavy flanged joints the number of which is kept to a minimum
 - they are to be of extra-reinforced wall thickness as per Pt C, Ch 1, Sec 10, Tab 5
 - they are to be adequately supported and protected against mechanical damage.

2.1.4 Draining of pump rooms (1/6/2021)

Cargo pumps or stripping pumps may be used for draining cargo pump rooms provided that:

- a screw-down non-return valve is fitted on the bilge suction, and
- a valve is fitted between the pump suction and the bilge distribution box.

Table 1 : Additional documents to be submitted for barge-oil (1/6/2021)

No.	Document (1)
1	General layout of cargo pump room with details of: <ul style="list-style-type: none"> • bulkhead penetrations • gas detection system • other alarms and safety arrangements
2	Diagram of cargo piping system
3	Diagram of the cargo tank venting system with: <ul style="list-style-type: none"> • indication of the outlet position • details of the pressure/vacuum valves and flame arrestors • details of the draining arrangements, if any
4	Diagram of the cargo tank level gauging system with overfill safety arrangements
5	Diagram of the cargo tank cleaning system
6	Diagram of the bilge and ballast systems serving the spaces located in the cargo area
7	Diagram of the cargo heating systems
8	Diagram of inert gas system with details of the inert gas plant
9	Diagram of gas measurement system for double hull and double bottom spaces
(1)	Diagrams are also to include, where applicable, the (local and remote) control and monitoring systems and automation systems.

2.1.5 Ballast system (1/6/2021)

Except where expressly permitted, ballast systems serving segregated ballast tanks are to be completely separated from the cargo oil and fuel oil systems.

In barges of 150 gross tonnage and above, no ballast water is normally to be carried in any fuel oil tank; see Pt C, Ch 1, Sec 10, [7.1.3].

Ballast pumps are to be located in the cargo pump room, or a similar space within the cargo area not containing any source of ignition.

Where installed in the cargo pump room, ballast pumps are to comply with the applicable provisions of [2.2.3] and [2.2.4].

Ballast systems serving segregated ballast in the cargo area are to be entirely located within the cargo area and are not to be connected to other piping systems.

Where they are intended to be filled with water ballast, the cofferdams located at the fore and aft ends of the cargo spaces may be emptied by a ballast pump located inside the machinery compartment or the forward space provided that:

- the suction is directly connected to the pump and not to a piping system serving machinery spaces
- the delivery is directly connected to the ship side.

Provisions may be made for emergency discharge of the segregated ballast by means of a connection to a cargo pump through a detachable spool piece provided that:

- non-return valves are fitted on the segregated ballast connections to prevent the passage of oil to the ballast tank, and
- shut-off valves are fitted to shut off the cargo and ballast lines before the spool piece is removed.

The detachable spool piece is to be placed in a conspicuous position in the pump room and a permanent warning notice restricting its use is to be displayed in a conspicuous position adjacent to it.

Provisions may be made for filling cargo tanks with sea water, where permitted. Such ballast water is to be dealt with as per [2.4].

The sea water inlets and overboard discharges serving cargo tanks for the purpose of a) are not to have any connection with the ballast system of segregated ballast tanks.

Cargo pumps may be used for pumping ballast water to or from the cargo tanks, provided two shut-off valves are fitted to isolate the cargo piping system from the sea inlets and overboard discharges. See also [2.4.10].

Ballast pumps serving segregated ballast tanks may be used for filling the cargo tanks with sea water provided that the connection is made on the top of the tanks and consists of a detachable spool piece and a screw-down non-return valve to avoid siphon effects.

In barges of 600 tonnes deadweight and above, ballast piping is not to pass through cargo tanks except in the case of short lengths of piping complying with [2.1.3] b).

Sliding type couplings are not to be used for expansion purposes where ballast lines pass through cargo tanks. Expansion bends only are permitted.

The fore peak tank can be ballasted with the system serving ballast tanks within the cargo area, provided:

- a) the fore peak tank is considered a hazardous area (see Note 1)
- b) the vent pipe openings are located on open deck at an appropriate distance from sources of ignition. In this respect, the separation distances for hazardous zones

are to be defined in accordance with IEC 60092-502: Electrical installations in ships - Tankers - Special features

- c) means are provided, on the open deck, to allow measurement of flammable gas concentrations within the fore peak tank by a suitable portable instrument
- d) the sounding arrangements to the fore peak tank are direct from the open deck.

Note 1: The hazardous area classification is to be defined in accordance with IEC 60092-502: Electrical installations in ships - Tankers - Special features.

2.1.6 Integrated cargo and ballast system (1/6/2021)

The requirements for integrated cargo and ballast systems are given in Ch 7, Sec 4, [3.5].

2.1.7 Air and sounding pipes of spaces other than cargo tanks (1/6/2021)

The air and sounding pipes fitted to the following spaces:

- cofferdams located at the fore and aft ends of the cargo spaces
- tanks and cofferdams located within the cargo area and not intended for cargo

are to be led to the open.

The air pipes referred to above are to be arranged as per Pt C, Ch 1, Sec 10, [9] and are to be fitted with easily removable flame screens at their outlets.

In barges of 600 tonnes deadweight and above, the air and sounding pipes referred above are not to pass through cargo tanks except in the following cases:

- short lengths of piping serving ballast tanks
- lines serving double bottom tanks located within the cargo area, except in the case of barges of 5000 tonnes deadweight and above where the provisions of [2.1.3], item b) are complied with.

2.1.8 Scupper pipes (1/6/2021)

Scupper pipes are not to pass through cargo tanks except, where this is impracticable, in the case of short lengths of piping complying with the following provisions:

- they are of steel
- they have only welded or heavy flanged joints the number of which is kept to a minimum
- they are of substantial wall thickness as per Pt C, Ch 1, Sec 10, Tab 22, column 1.

2.1.9 Heating systems intended for cargo (1/6/2021)

- a) Heating systems intended for cargo are to comply with the relevant requirements of Pt C, Ch 1, Sec 10.
- b) The steam and heating media temperature within the cargo area is not to exceed 220° C.
- c) Blind flanges or similar devices are to be provided on the heating circuits fitted to tanks carrying cargoes which are not to be heated.
- d) Heating systems are to be so designed that the pressure maintained in the heating circuits is higher than that exerted by the cargo oil. This need not be applied to

heating circuits which are not in service provided they are drained and blanked-off.

- e) Isolating valves are to be provided at the inlet and outlet connections of the tank heating circuits. Arrangements are to be made to allow manual adjustment of the flow.
- f) Heating pipes and coils inside tanks are to be built of a material suitable for the heated fluid. They are to have welded connections only.
- g) To reduce the risk of liquid or gaseous cargo returns inside the engine or boiler rooms, steam heating systems of cargo tanks are to satisfy either of the following provisions:
 - they are to be independent of other ship services, except cargo heating or cooling systems, and are not to enter machinery spaces, or
 - they are to be provided with an observation tank on the water return system located within the cargo area. However, this tank may be placed inside the engine room in a well-ventilated position remote from boilers and other sources of ignition. Its air pipe is to be led to the open and fitted with a flame arrester.
- h) Hot water systems serving cargo tanks are to be independent of other systems. They are not to enter machinery spaces unless the expansion tank is fitted with:
 - means for detection of flammable vapours
 - a vent pipe led to the open and provided with a flame arrester.
- i) Thermal oil heating systems serving cargo tanks are to be arranged by means of a separate secondary system, located completely within the cargo area. However, a single circuit system may be accepted provided that:
 - the system is so arranged as to ensure a positive pressure in the coil of at least 3 m water column above the static head of the cargo when the circulating pump is not in operation
 - means are provided in the expansion tank for detection of flammable cargo vapours. Portable equipment may be accepted
 - valves for the individual heating coils are provided with a locking arrangement to ensure that the coils are under static pressure at all times.

2.2 Cargo pumping system

2.2.1 Number and location of cargo pumps (1/6/2021)

Arrangements are to be adopted to make discharge by pumps in the oil terminal possible, taking into account the NPSHD at the pumps, or a fixed mean of discharging and stripping is to be fitted.

Cargo pumps are to be located:

- in a dedicated pump room, or
- on deck, or
- when designed for this purpose, within the cargo tanks.

2.2.2 Use of cargo pumps (1/6/2021)

Except where expressly permitted in [2.1.5] and Sec 3, [2.2.1], cargo pumps are to be used exclusively for handling

the liquid cargo and are not to have any connections to compartments other than cargo tanks.

Subject to their performance, cargo pumps may be used for tank stripping.

Cargo pumps may be used, where necessary, for the washing of cargo tanks

2.2.3 Cargo pumps drive (1/6/2021)

a) Prime movers of cargo pumps are not to be located in the cargo area, except in the following cases:

- steam driven machine supplied with steam having a temperature not exceeding 220 °C
- hydraulic motors
- electric motors of certified explosion proof type.

b) Pumps with a submerged electric motor are not permitted in cargo tanks.

Where cargo pumps are driven by a machine which is located outside the cargo pump room, the following arrangements are to be made:

- 1) drive shafts are to be fitted with flexible couplings or other means suitable to compensate for any misalignment
- 2) the shaft bulkhead or deck penetration is to be fitted with a gas-tight gland of a type approved by the Society. The gland is to be efficiently lubricated from outside the pump room and so designed as to prevent overheating. The seal parts of the gland are to be of material that cannot initiate sparks.
- 3) temperature sensing devices are to be fitted for bulkhead shaft gland bearings.

Note 1: The provisions of this requirement also apply to stripping pumps and ballast pumps.

2.2.4 Design of cargo pumps (1/6/2021)

a) Materials of cargo pumps are to be suitable for the products carried.

b) The delivery side of cargo pumps is to be fitted with relief valves discharging back to the suction side of the pumps (bypass) in closed circuit. Such relief valves may be omitted in the case of centrifugal pumps with a maximum delivery pressure not exceeding the design pressure of the piping, with the delivery valve closed.

c) Pump casings are to be fitted with temperature sensing devices; see [2.2.5].

2.2.5 Monitoring of cargo pumps (1/6/2021)

Cargo pumps are to be monitored as required in Tab 2.

2.2.6 Control of cargo pumps (1/6/2021)

Cargo pumps are to be capable of being stopped from:

- a position outside the pump room, and
- a position next to the pumps.

2.2.7 Cargo piping design (1/6/2021)

Unless otherwise specified, cargo piping is to be designed and constructed according to the requirements of Pt C, Ch 1, Sec 10 applicable to piping systems of class III.

- For tests, refer to Sec 4, [4].
- Cargo piping is, in general, to be made of steel or cast iron.
- Valves, couplings and other end fittings of cargo pipe lines for connection to hoses are to be of steel or other suitable ductile material.
- Spheroidal graphite cast iron may be used for cargo oil piping.
- Grey cast iron may be accepted for cargo oil lines:
 - within cargo tanks, and
 - on the weather deck for pressure up to 1,6 Mpa.

It is not to be used for manifolds and their valves of fittings connected to cargo handling hoses.

- Plastic pipes may be used in the conditions specified in Pt C, Ch 1, App 3. Arrangements are to be made to avoid the generation of static electricity.

Cargo pipe lengths may be connected either by means of welded joints or, unless otherwise specified, by means of flange connections.

Where necessary, cargo piping is to be fitted with expansion joints or bends.

Expansion joints including bellows are to be of a type approved by the Society.

Expansion joints made of non-metallic material may be accepted only inside tanks and provided they are:

- of an approved type
- designed to withstand the maximum internal and external pressure
- electrically conductive

Sliding type couplings are not to be used for expansion purposes where lines for cargo oil pass through tanks for segregated ballast.

Valves with remote control are to comply with Pt C, Ch 1, Sec 10, [2.7.3].

Submerged valves are to be remote controlled. In the case of a hydraulic remote control system, control boxes are to be provided outside the tank, in order to permit the emergency control of valves.

Valve actuators located inside cargo tanks are not to be operated by means of compressed air.

Cargo hoses are to be of a type approved by the Society for the intended conditions of use.

Hoses subject to tank pressure or pump discharge pressure are to be designed for a bursting pressure not less than 4 times the maximum pressure under cargo transfer conditions.

The ohmic electrical resistance of cargo hoses is not to exceed 10⁶ Ω .

Table 2 : Monitoring of cargo pumps (1/6/2021)

Equipment, parameter	Alarm (1)	Indication (2)	Comments
pump, discharge pressure	-	L	<ul style="list-style-type: none"> on the pump (3), or next to the unloading control station
pump casing, temperature	H		visual and audible, in cargo control room or pump control station
bulkhead shaft gland bearing, temperature	H		visual and audible, in cargo control room or pump control station
<p>(1) H = high (2) L = low (3) and next to the driving machine if located in a separate compartment</p>			

2.2.8 Cargo piping arrangement and installation (1/6/2021)

Cargo piping is not to pass through tanks or compartments located outside the cargo area.

Cargo piping and similar piping to cargo tanks is not to pass through ballast tanks except in the case of short lengths of piping complying with [2.1.3] b).

Cargo piping may pass through vertical fuel oil tanks adjacent to cargo tanks on condition that the provisions of [2.1.3] b) are complied with.

Piping through cargo tanks, see also Ch 7, Sec 2, [3.1.4].

Cargo piping passing through bulkheads is to be so arranged as to preclude excessive stresses at the bulkhead. Bolted flanges are not to be used in the bulkhead.

Stop valves are to be provided to isolate each tank.

A stop valve is to be fitted at each end of the cargo manifold.

When a cargo pump in the cargo pump room serves more than one cargo tank, a stop valve is to be fitted in the cargo pump room on the line leading to each tank.

Main cargo oil valves located in the cargo pump room below the floor gratings are to be remote controlled from a position above the floor.

To avoid the hazard of an incendive discharge due to the build-up of static electricity resulting from the flow of the liquid/gases/vapours, the following requirements are to be complied with:

- the loading pipes are to be led as low as practicable in the tank
- the resistance between any point on the surface of the cargo and slop tanks, piping systems and equipment, and the hull of the ship is not to be greater than $10^6 \Omega$.

Bonding straps are required for cargo and slop tanks, piping systems and equipment which are not permanently connected to the hull of the ship, for example:

- independent cargo tanks
- cargo tank piping systems which are electrically separated from the hull of the ship
- pipe connections arranged for the removal of the spool pieces.

Where bonding straps are required, they are to be:

- clearly visible so that any shortcoming can be clearly detected
- designed and sited so that they are protected against mechanical damage and are not affected by high resistivity contamination, e.g. corrosive products or paint
- easy to install and replace.

Where the ship is arranged for loading and unloading outside the cargo area, the following provisions are to be complied with:

- the piping outside the cargo area is to be fitted with a shut-off valve at its connection with the piping system within the cargo area and separating means such as blank flanges or removable spool pieces or equivalent (see Note 1) are to be provided when the piping within the cargo area is not in use
- the shore connection is to be fitted with a shut-off valve and a blank flange

Note 1: Those indicated in the IMO MSC/Circ. 474 are acceptable as equivalent

- pipe connections outside the cargo area are to be of welded type only
- arrangements are made to allow the piping outside the cargo area to be efficiently drained and purged.

2.3 Cargo tanks and fittings

2.3.1 (1/6/2021)

The provisions of this paragraph apply to cargo tanks and slop tanks.

2.3.2 Cargo tank venting (1/6/2021)

Cargo tanks are to be provided with venting systems entirely distinct from the air pipes of the other compartments of the ship. The arrangements and position of openings in the cargo tank deck from which emission of flammable vapours can occur are to be such as to minimise the possibility of flammable vapours being admitted to enclosed spaces containing a source of ignition, or collecting in the vicinity of deck machinery and equipment which may constitute an ignition hazard.

2.3.3 Design of venting arrangements (1/6/2021)

The venting arrangements are to be so designed and operated as to ensure that neither pressure nor vacuum in cargo tanks exceeds design parameters and be such as to provide for:

- a) the flow of the small volumes of vapour, air or inert gas mixtures caused by thermal variations in a cargo tank in all cases through pressure/vacuum valves, and
- b) the passage of large volumes of vapour, air or inert gas mixtures during cargo loading and ballasting, or during discharging,
- c) a secondary means of allowing full flow relief of vapour, air or inert gas mixtures to prevent overpressure or underpressure in the event of failure of the arrangements in b). Alternatively, pressure sensors may be fitted in each tank protected by the arrangement required in b), with a monitoring system in the ship's cargo control room or the position from which cargo operations are normally carried out. Such monitoring equipment is also to provide an alarm facility which is activated by detection of overpressure or underpressure conditions within a tank.

2.3.4 Combination of venting arrangements (1/6/2021)

- a) the venting arrangements in each cargo tank may be independent or combined with other cargo tanks and may be incorporated into the inert gas piping.
- b) where the arrangements are combined with other cargo tanks, either stop valves or other acceptable means are to be provided to isolate each cargo tank. Where stop valves are fitted, they are to be provided with locking arrangements which are to be under the control of the responsible ship's officer. There is to be a clear visual indication of the operational status of the valves or other acceptable means. Where tanks have been isolated, it is to be ensured that relevant isolating valves are opened before cargo loading or ballasting or discharging of those tanks is commenced. Any isolation must continue to permit the flow caused by thermal variations in a cargo tank in accordance with [2.3.3] a).
- c) if cargo loading or ballasting or discharging of a cargo tank or cargo tank group is intended, which is isolated from a common venting system, that cargo tank or cargo tank group is to be fitted with a means for overpressure or underpressure protection as required in [2.3.3] c).

2.3.5 Arrangement of vent lines (1/6/2021)

The venting arrangements are to be connected to the top of each cargo tank and are to be self-draining to the cargo tanks under all normal conditions of trim and list of the ship. Where it may not be possible to provide self-draining lines, permanent arrangements are to be provided to drain the vent lines to a cargo tank.

Plugs or equivalent means are to be provided on the lines after the safety relief valves.

2.3.6 Openings for pressure release (1/6/2021)

Openings for pressure release required by [2.3.3] a) are to:

- a) have as great a height as is practicable above the cargo tank deck to obtain maximum dispersal of flammable

vapours but in no case less than 2 m above the cargo tank deck,

- b) be arranged at the furthest distance practicable but not less than 5 m from the nearest air intakes and openings to enclosed spaces containing a source of ignition and from deck machinery and equipment which may constitute an ignition hazard. Anchor windlass and chain locker openings constitute an ignition hazard.

2.3.7 Pressure/vacuum valves (1/6/2021)

- a) One or more pressure/vacuum-breaking devices are to be provided to prevent the cargo tanks from being subject to:
 - 1) a positive pressure, in excess of the test pressure of the cargo tank, if the cargo were to be loaded at the maximum rated capacity and all other outlets were left shut; and
 - 2) a negative pressure in excess of 700 mm water gauge if cargo were to be discharged at the maximum rated capacity of the cargo pumps and the inert gas blowers were to fail.

Such devices are to be installed on the inert gas main unless they are installed in the venting system required by this item [2.3] or on individual cargo tanks.

- b) Pressure/vacuum valves are to be set at a positive pressure not exceeding 0,021 MPa and at a negative pressure not exceeding 0,007 MPa. Higher setting values not exceeding 0,07 MPa may be accepted in positive pressure if the scantlings of the tanks are appropriate.
- c) Pressure/vacuum valves required by [2.3.3] a) may be provided with a bypass when they are located in a vent main or masthead riser. Where such an arrangement is provided, there are to be suitable indicators to show whether the bypass is open or closed
- d) Pressure/vacuum valves are to be of a type approved by the Society in accordance with Ch 7, App 1.
- e) Pressure/vacuum valves are to be readily accessible.
- f) Pressure/vacuum valves are to be provided with a manual opening device so that valves can be locked on open position. Locking means on closed position are not permitted.

2.3.8 Vent outlets (1/6/2021)

Vent outlets for cargo loading, discharging and ballasting required by [2.3.3] b) are to:

- a) permit:
 - 1) the free flow of vapour mixtures, or
 - 2) the throttling of the discharge of the vapour mixtures to achieve a velocity of not less than 30 m/s,
- b) be so arranged that the vapour mixture is discharged vertically upwards
- c) where the method is by free flow of vapour mixtures, be such that the outlet is not less than 6 m above the cargo tank deck or fore and aft gangway if situated within 4 m of the gangway and located not less than 10 m measured horizontally from the nearest air intakes and openings to enclosed spaces containing a source of ignition and from deck machinery which may include anchor

windlass and chain locker openings, and equipment which may constitute an ignition hazard,

- d) where the method is by high velocity discharge, be located at a height not less than 2 m above the cargo tank deck and not less than 10 m measured horizontally from the nearest air intakes and openings to enclosed spaces containing a source of ignition and from deck machinery which may include anchor windlass and chain locker openings, and equipment which may constitute an ignition hazard. These outlets are to be provided with high velocity devices of a type approved by the Society,
- e) be designed on the basis of the maximum designed loading rate multiplied by a factor of at least 1,25 to take account of gas evolution, in order to prevent the pressure in any cargo tank from exceeding the design pressure. The Master is to be provided with information regarding the maximum permissible loading rate for each cargo tank and in the case of combined venting systems, for each group of cargo tanks.

The arrangements for the venting of vapours displaced from the cargo tanks during loading and ballasting are to comply with this item [2.3] and are to consist of either one or more mast risers, or a number of high-velocity vents. The inert gas supply main may be used for such venting.

2.3.9 High velocity valves (1/6/2021)

- a) High velocity valves are to be readily accessible
- b) High velocity valves not required to be fitted with flame arresters (see [2.3.10]) are not to be capable of being locked on open position.

2.3.10 Prevention of the passage of flame into the tanks (1/6/2021)

- a) The venting system is to be provided with devices to prevent the passage of flame into the cargo tanks. The design, testing and locating of these devices are to comply with Ch 7, App 1.

Ullage openings are not to be used for pressure equalisation. They are to be provided with self-closing and tightly sealing covers. Flame arresters and screens are not permitted in these openings.

- b) A flame arresting device integral to the venting system may be accepted.
- c) Flame screens and flame arresters are to be designed for easy overhauling and cleaning.

2.3.11 Prevention of liquid rising in the venting system (1/6/2021)

- a) Provisions are to be made to prevent liquid rising in the venting system; refer to [2.3.16].
- b) Cargo tanks gas venting systems are not to be used for overflow purposes.
- c) Spill valves are not considered equivalent to an overflow system.

2.3.12 Cargo tank purging and/or gas-freeing (1/6/2021)

- a) Arrangements are to be made for purging and/or gas-freeing of cargo tanks. The arrangements are to be such as to minimise the hazards due to the dispersal of flammable vapours in the atmosphere and to flammable mixtures in a cargo tank. Accordingly, the provisions of [2.3.13] and [2.3.14], as applicable, are to be complied with.
- b) In the case of fans installed in safe spaces, two non-return devices are to be fitted to avoid return of cargo vapours to safe spaces when the ventilation system is shut down. These non-return devices are to operate in all normal conditions of ship trim and list.
- c) Discharge outlets are to be located at least 10 m measured horizontally from the nearest air intake and openings to enclosed spaces with a source of ignition and from deck machinery equipment which may constitute an ignition hazard.

2.3.13 Ships provided with an inert gas system (1/6/2021)

When the ship is provided with an inert gas system, the cargo tanks are first to be purged in accordance with the provisions of Part C, Chapter 4 until the concentration of hydrocarbon vapours in the cargo tanks has been reduced to less than 2% by volume. Thereafter, gas-freeing may take place at the cargo tank deck level.

2.3.14 Ships not provided with an inert gas system (1/6/2021)

When the ship is not provided with an inert gas system, the operation is to be such that the flammable vapour is discharged initially:

- a) through the vent outlets as specified in [2.3.8], or
- b) through outlets at least 2 m above the cargo tank deck level with a vertical efflux velocity of at least 30 m/s maintained during the gas-freeing operation, or
- c) through outlets at least 2 m above the cargo tank deck level with a vertical efflux velocity of at least 20 m/s and which are protected by suitable devices to prevent the passage of flame.

The above outlets are to be located not less than 10 m measured horizontally from the nearest air intakes and openings to enclosed spaces containing a source of ignition and from deck machinery, which may include anchor windlass and chain locker openings, and equipment which may constitute an ignition hazard.

When the flammable vapour concentration at the outlet has been reduced to 30% of the lower flammable limit, gas-freeing may thereafter be continued at cargo tank deck level.

2.3.15 Cargo tank level gauging systems (1/6/2021)

- a) Each cargo or slop tank is to be fitted with a level gauging system indicating the liquid level along the entire height of the tank. Unless otherwise specified, the gauge may be portable or fixed with local reading.
- b) Gauging devices and their remote reading systems are to be type approved.

c) Ullage openings and other gauging devices likely to release cargo vapour to the atmosphere are not to be arranged in enclosed spaces.

- 1) a "restricted gauging device" means a device which penetrates the tank and which, when in use, permits a small quantity of vapour or liquid to be exposed to the atmosphere. When not in use, the device is completely closed. Examples are sounding pipes.
- 2) a "closed gauging device" means a device which is separated from the tank atmosphere and keeps tank contents from being released. It may:
 - penetrate the tank, such as float-type systems, electric probe, magnetic probe or protected sight glass,
 - not penetrate the tank, such as ultrasonic or radar devices.
- 3) an "indirect gauging device" means a device which determines the level of liquid, for instance by means of weighing or pipe flow meter.

In barges fitted with an inert gas system, the gauging devices are to be of the closed type: use of indirect gauging devices will be given special consideration.

In barges not fitted with an inert gas system:

- the gauging devices are to be of the closed or restricted types. Ullage openings may be used only as a reserve sounding means and are to be fitted with a watertight closing appliance.
- Where restricted gauging devices are used, provisions are to be made to avoid dangerous escape of liquid or vapour under pressure when using the device relieve the pressure in the tank before the device is operated.
- Where used, sounding pipes are to be fitted with a self-closing blanking device.

2.3.16 Protection against tank overload (1/6/2021)

Provisions are to be made to guard against liquid rising in the venting system of cargo or slop tanks to a height which would exceed the design head of the tanks. This is to be accomplished by high level alarms or overflow control systems or other equivalent means, together with gauging devices and cargo tank filling procedures.

Sufficient ullage is to be left at the end of tank filling to permit free expansion of liquid during carriage.

High level alarms, overflow control systems and other means referred to above are to be independent of the gauging systems referred to in [2.3.15].

High level alarms are to be type approved.

High level alarms are to give an audible and visual signal at the control station, where provided.

Where the tank level gauging systems, cargo and ballast pump control systems and valve control systems are centralised in a single location, the provisions above may be complied with by the fitting of a level gauge for the indication of the end of loading, in addition to that required for each tank under [2.3.15]. The readings of both gauges for each tank are to be as near as possible to each other and so arranged that any discrepancy between them can be easily detected.

2.3.17 Tank washing systems (1/6/2021)

Adequate means are to be provided for cleaning the cargo tanks, except on units which:

- are dedicated to the same type of cargo for many consecutive voyages, and
- are arranged with segregated ballast tanks according to Sec 2, [5], and
- do not carry out tank washing on a regular basis, and
- use shore services for tank washing and disposal of washing media and residues, when needed.

Crude oil washing systems, when fitted, are to comply with the provisions of Ch 7, App 2 related to safety.

Tank washing machines are to be of a type approved by the Society.

Washing machines are to be made of steel or other electricity conducting materials with a limited propensity to produce sparks on contact.

Washing pipes are to be built, fitted, inspected and tested in accordance with the applicable requirements of Pt C, Ch 1, Sec 10, depending on the kind of washing fluid, water or crude oil.

Crude oil washing pipes are also to satisfy the requirements of [2.2.7].

Crude oil washing machines may be connected to water washing pipes, provided that isolating arrangements, such as a valve and a detachable pipe section, are fitted to isolate water pipes.

Tank cleaning openings are not to be arranged in enclosed spaces.

The complete installation is to be permanently earthed to the hull.

2.4 Prevention of pollution by cargo oil

2.4.1 Application (1/6/2021)

Unless otherwise specified, the provisions of [2.4.4], [2.4.5] and [2.4.6] apply only to barges of 150 gross tonnage and above.

2.4.2 Provisions for barges of less than 150 gross tonnage (1/6/2021)

The control of discharge for **barges** of less than 150 gross tonnage is to be effected by the retention of oil on board with subsequent discharge of all contaminated washings to reception facilities unless adequate arrangements are made to ensure that the discharge of any effluent into the sea, where allowed, is effectively monitored to ensure that the total quantity of oil discharged into the sea does not exceed 1/30 000 of the total quantity of the particular cargo of which the residue formed a part.

2.4.3 Exemptions (1/6/2021)

The provisions of [2.4.4] and [2.4.5] may be waived in the following cases:

- barges engaged exclusively on voyages within 50 miles from the nearest land and of 72 hours or less in duration and limited to trades between ports or terminals agreed

by the Society, provided that oily mixtures are retained on board for subsequent discharge to reception facilities

- carrying products which through their physical properties inhibit effective product/water separation and monitoring, for which the control of discharge is to be effected by the retention of residues on board with discharge of all contaminated washings to reception facilities.

2.4.4 Retention of oil on board (1/6/2021)

Adequate means are to be provided for transferring the dirty ballast residue and tank washings from the cargo tanks into a slop tank approved by the Society.

2.4.5 Capacity of slop tanks (1/6/2021)

The arrangement of the slop tank or combination of slop tanks is to have a capacity necessary to retain the slop generated by tank washings, oil residues and dirty ballast residues. The total capacity of the slop tank or tanks is not to be less than 3% of the oil carrying capacity of the ship, except that the Society may accept:

- 2% for barges where the tank washing arrangements are such that once the slop tank or tanks are charged with washing water, this water is sufficient for tank washing and, where applicable, for providing the driving fluid for eductors, without the introduction of additional water into the system
- 2% where segregated ballast tanks are provided, or where a cargo tank cleaning system using crude oil washing is fitted in accordance with [2.3.17]. This capacity may be further reduced to 1,5% for barges where the tank washing arrangements are such that once the slop tank or tanks are charged with washing water, this water is sufficient for tank washing and, where applicable, for providing the driving fluid for eductors, without introduction of additional water into the system
- slop tanks of any size, including absence of dedicated slop tanks, for units which:
 - are dedicated to the same type of cargo for many consecutive voyages, and
 - are arranged with segregated ballast tanks, and
 - do not carry out tank washing on a regular basis.

Barges of 70 000 tonnes deadweight and above are to be fitted with at least two slop tanks.

2.4.6 Design of slop tanks (1/6/2021)

Slop tanks are to be so designed particularly in respect of the position of inlets, outlets, baffles or weirs where fitted, as to avoid excessive turbulence and entrainment of oil or emulsion with the water.

2.4.7 Pumping, piping and discharge arrangements (1/6/2021)

In every barge, a discharge manifold for connection to reception facilities for the discharge of dirty ballast water or oil contaminated water is to be located on the open deck on both sides of the ship.

2.4.8 Discharge pipelines (1/6/2021)

In every barge, pipelines for the discharge of ballast water or oil contaminated water from cargo tank areas to the sea, where permitted, are to be led to the open deck or to the ship side above the waterline in the deepest ballast condition, except that:

- segregated ballast and clean ballast may be discharged below the waterline:
 - in ports or at offshore terminals, or
 - at sea by gravity,
 provided that the surface of the ballast water has been examined immediately before the discharge to ensure that no contamination with oil has taken place.
- on every barge at sea, dirty ballast water or oil contaminated water from tanks in the cargo area, other than slop tanks, may be discharged by gravity below the waterline, provided that sufficient time has elapsed in order to allow oil/water separation to have taken place and the water ballast has been examined immediately before the discharge with an oil/water interface detector, in order to ensure that the height of the interface is such that the discharge does not involve any increased risk of harm to the marine environment.

2.4.9 Discharge stopping (1/6/2021)

Means are to be provided for stopping the discharge into the sea of ballast water or oil contaminated water from cargo tank areas, other than those discharges below the waterline permitted under [2.4.8], from a position on the upper deck or above located so that the manifold in use referred to [2.4.7] in and the discharge to the sea from the pipelines referred to [2.4.8] may be visually observed. Means for stopping the discharge need not be provided at the observation position if a positive communication system such as a telephone or radio system is provided between the observation position and the discharge control position.

2.4.10 Cargo piping connections to sea chests (1/6/2021)

On every barge where a sea chest is permanently connected to the cargo pipeline system, it is to be equipped with both a sea chest valve and an inboard isolation valve. In addition to these valves, the sea chest is to be capable of isolation from the cargo piping system whilst the barge is loading, transporting or discharging cargo by use of a positive means that is to the satisfaction of the Society. Such a positive means is a facility that is installed in the pipeline system in order to prevent the section of pipeline between the sea chest valve and the inboard valve being filled with cargo under all circumstances.

Examples of positive means may take the form of blanks, spectacle blanks, pipeline blinds, evacuation or vacuum systems, or air or water pressure systems. In the event that evacuation or vacuum systems, or air or water pressure systems are used, then they are to be equipped with both a pressure gauge and alarm system to enable the continuous monitoring of the status of the pipeline section, and thereby the valve integrity, between the sea chest and inboard valves.

3 Additional requirements for barge-oil intended to carry products having flashpoint > 60°C

3.1 Piping systems other than cargo piping system

3.1.1 (1/6/2021)

The requirements in [2.1] are applicable with the following exceptions.

3.1.2 Independence of piping systems (1/6/2021)

Requirements in [2.1.2] are applicable except for item a) and third bullet of item b).

3.1.3 Draining of pump rooms (1/6/2021)

Requirements in [2.1.4] are applicable except for second bullet.

3.1.4 Ballast system (1/6/2021)

In lieu of the requirements in [2.1.5] the following applies.

Except where expressly permitted, ballast systems serving segregated ballast tanks are to be completely separated from the cargo oil and fuel oil systems.

In barges of 150 gross tonnage and above, no ballast water is normally to be carried in any fuel oil tank; see Pt C, Ch 1, Sec 10, [7.1.3].

The mean intended to pump from segregated ballast tanks is to be a pump or an eductor used exclusively for dealing with ballast. The ballast system serving the spaces located outside the cargo area may be used for this purpose.

Provisions may be made for emergency discharge of the segregated ballast by means of a connection to a cargo pump through a detachable spool piece provided that:

- non-return valves are fitted on the segregated ballast connections to prevent the passage of oil to the ballast tank, and
- shut-off valves are fitted to shut off the cargo and ballast lines before the spool piece is removed.

The detachable spool piece is to be placed in a conspicuous position in the pump room and a permanent warning notice restricting its use is to be displayed in a conspicuous position adjacent to it.

Provisions may be made for filling cargo tanks with sea water, where permitted. Such ballast water is to be dealt with as per Ch 7, Sec 5, [5].

The sea water inlets and overboard discharges serving cargo tanks for the purpose of a) are not to have any connection with the ballast system of segregated ballast tanks.

Cargo pumps may be used for pumping ballast water to or from the cargo tanks, provided two shut-off valves are fitted to isolate the cargo piping system from the sea inlets and overboard discharges. See also [2.4.10].

Ballast pumps serving segregated ballast tanks may be used for filling the cargo tanks with sea water provided that the

connection is made on the top of the tanks and consists of a detachable spool piece and a screw-down non-return valve to avoid siphon effects.

In oil barges of 600 tonnes deadweight and above, ballast piping is not to pass through cargo tanks except in the case of short lengths of piping complying with [2.1.3] b).

Sliding type couplings are not to be used for expansion purposes where ballast lines pass through cargo tanks. Expansion bends only are permitted.

3.1.5 Heating systems intended for cargo (1/6/2021)

The requirements in [2.1.9] are not applicable.

3.2 Cargo pumping system

3.2.1 Number and location of cargo pumps (1/5/2013)

Each cargo tank is to be served by at least one fixed mean of discharging and stripping. As an alternative, arrangements are to be adopted to make discharge by pumps in the oil terminal possible, taking into account the NPSHD at the pumps.

3.2.2 Use of cargo pumps (1/5/2013)

- a) Except where expressly permitted in [3.1.4] and Sec 3, [2.2.1] cargo pumps are to be used exclusively for handling the liquid cargo and are not to have any connections to compartments other than cargo tanks.
- b) Subject to their performance, cargo pumps may be used for tank stripping.
- c) Cargo pumps may be used, where necessary, for the washing of cargo tanks.

3.2.3 Cargo pump drive (1/5/2013)

Pumps with a submerged electric motor are not permitted in cargo tanks.

Note 1: The provisions of this requirement also apply to stripping pumps and ballast pumps.

3.2.4 Design of cargo pumps (1/5/2013)

- a) Materials of cargo pumps are to be suitable for the products carried.
- b) The delivery side of cargo pumps is to be fitted with relief valves discharging back to the suction side of the pumps (bypass) in closed circuit. Such relief valves may be omitted in the case of centrifugal pumps with a maximum delivery pressure not exceeding the design pressure of the piping, with the delivery valve closed.

3.2.5 Monitoring of cargo pumps (1/5/2013)

Cargo pumps are to be monitored as required in Tab 3.

3.2.6 Control of cargo pumps (1/5/2013)

Cargo pumps are to be capable of being stopped from:

- a position outside the pump room, and
- a position next to the pumps.

Table 3 : Monitoring of cargo pumps (1/5/2013)

Equipment, parameter	Alarm	Indication (1)	Comments
pump, discharge pressure		L	<ul style="list-style-type: none"> on the pump (2), or next to the unloading control station
(1) L = low			
(2) and next to the driving machine if located in a separate compartment			

3.3 Cargo piping

3.3.1 Cargo piping design (1/6/2021)

The requirements in [2.2.7] are applicable.

3.3.2 Cargo pipes passing through tanks or compartments (1/5/2013)

- Cargo piping and similar piping to cargo tanks is not to pass through ballast tanks except in the case of short lengths of piping complying with [2.1.3], item b).
- Cargo piping may pass through vertical fuel oil tanks adjacent to cargo tanks on condition that the provisions of [2.1.3], item b) are complied with.

3.3.3 Cargo piping passing through bulkheads (1/5/2013)

Cargo piping passing through bulkheads is to be so arranged as to preclude excessive stresses at the bulkhead. Bolted flanges are not to be used in the bulkhead.

3.3.4 Valves (1/5/2013)

- Stop valves are to be provided to isolate each tank.
- A stop valve is to be fitted at each end of the cargo manifold.
- When a cargo pump in the cargo pump room serves more than one cargo tank, a stop valve is to be fitted in the cargo pump room on the line leading to each tank.
- Main cargo oil valves located in the cargo pump room below the floor gratings are to be remote controlled from a position above the floor.

3.4 Cargo tanks and fittings

3.4.1 Application (1/6/2021)

The provisions of [3.4] apply to cargo tanks and slop tanks.

3.4.2 Cargo tank venting (1/5/2013)

The relevant provisions of Pt C, Ch 1, Sec 10, [9] and Pt C, Ch 1, Sec 10, [11] are to be complied with.

Tank venting systems are to open to the atmosphere at a height of at least 760 mm above the weather deck. If the cargo is carried at a temperature exceeding the flashpoint by more than 15°C, this height is to be increased to 2,4 m.

Tanks may be fitted with venting systems of the open type provided with a flame screen. For ships carrying bulk cargoes with flashpoint > 100°C, the flame screen may be omitted.

3.4.3 Protection against tank overload (1/6/2021)

The requirements in [2.3.16] are applicable.

3.4.4 Tank washing systems (1/6/2021)

The requirements in [2.3.17] are applicable

3.5 Prevention of pollution by cargo oil

3.5.1 (1/6/2021)

The requirements in [2.4] are applicable with the following additional exemption:

3.5.2 (1/5/2013)

Where, in the view of the Society, the equipment referred to in [2.4.7] and [2.4.8] is not obtainable for the monitoring of discharge of oil refined products (white oils), compliance with such requirements may be waived provided that discharge is performed only in accordance with the applicable procedures.

4 Certification, inspection and testing

4.1

4.1.1 (1/6/2021)

The provisions of Ch 7, Sec 4, [6] are applicable to barge-oil intended to carry oil having any flashpoint (i.e. including oils having flash point < 60°C).

The provisions of Ch 7, Sec 5, [6] are applicable to barge-oil intended to carry only oil having flashpoint > 60°C.

SECTION 5

ADDITIONAL REQUIREMENTS FOR MACHINERY AND CARGO SYSTEMS OF BARGE-LIQUEFIED GAS

1 General

1.1 Application

1.1.1 (1/6/2021)

These units are to comply with the requirements of Sec 3.

The requirements in this Section are additional to the ones in Sec 3.

These units are to comply with the requirements of the latest version of the International Code for the Construction and Equipment of Ships Carrying Liquefied Gases in Bulk (IGC Code), as amended, as specified in Ch 9, [1.1.1] and [1.1.2].

The requirements of this Section supplement those of the IGC Code.

All the requirements of this Section are cross referenced to the applicable Chapters, Sections or paragraphs of the IGC Code, as appropriate.

1.2 Documents to be submitted

1.2.1 (1/6/2021)

The documents listed in Tab 1 are to be submitted for approval.

1.3 Exemptions

1.3.1 (1/6/2021)

The requirements in Pt C, Ch 1, Sec 10, [11.4.1] b) do not apply to service tanks.

The requirements in Pt C, Ch 1, Sec 10, [11.4.6] a) do not apply.

Table 1 : Documents to be submitted (1/6/2021)

No	A/I	Documents
1	I	List of products to be carried, including maximum vapour pressure, maximum liquid temperature and other important design conditions
2	I	P&A manual, when applicable
3	A	Ventilation duct arrangement in gas-dangerous spaces and adjacent zones
4	A	Plans, arrangement and calculations of safety relief valves
5	A	Details of cargo handling and vapour system, including arrangements and details of piping and fitting
6	A	Details of cargo pumps and cargo compressors
7	A	Details of process pressure vessels and relative valving arrangement
8	A	Piping stress analysis when $T < -110^{\circ}\text{C}$
9	A	Cargo operating manual
10	A	Bilge and ballast system in cargo area
11	A	Gas freeing system in cargo tanks including inert gas system
12	A	Interbarrier space drainage, inerting and pressurisation systems
13	A	Ventilation system in cargo area
14	A	Refrigeration and reliquefaction plant system diagram, if any
15	A	Gas detection system
Note 1: A = to be submitted for approval in four copies I = to be submitted for information in duplicate		

No	A/I	Documents
16	A	Loading and unloading operation description, including cargo tank filling limits
17	A	Cargo tank testing and inspection procedures
Note 1: A = to be submitted for approval in four copies I = to be submitted for information in duplicate		

2 Cargo pump rooms and cargo compressor rooms

2.1 Equipment in cargo pump rooms and cargo compressor rooms

2.1.1 (1/6/2021)

IGC CODE REFERENCE : Ch 3, 3.3

Cargo pump rooms and/or cargo compressor rooms of ships carrying flammable gases may not contain electrical equipment, except as provided for in Chapter 10 of the IGC Code, or other ignition sources such as internal combustion engines or steam engines with operating temperature which could cause ignition or explosion of mixtures of such gases, if any, with air.

3 Bilge, ballast and fuel oil arrangements

3.1 Drainage arrangement

3.1.1 Drainage of dry spaces in the cargo area (1/6/2021)

IGC CODE REFERENCE : Ch 3, 3.7

Dry spaces within the cargo area are to be fitted with a bilge or drain arrangement not connected to the machinery space.

Spaces not accessible at all times are to be fitted with sounding arrangements.

Spaces without a permanent ventilation system are to be fitted with a pressure/vacuum relief system or with air pipes.

3.2 Additional requirements relative to the bilge system

3.2.1 Operation of the bilge system in cargo and interbarrier spaces (1/6/2021)

IGC CODE REFERENCE : Ch 3, 3.7

Bilge arrangements for holds containing cargo tanks and for interbarrier spaces are to be operable from the weather deck.

3.2.2 Means for leakage detection (1/6/2021)

IGC CODE REFERENCE : Ch 3, 3.7

With reference to the means to ascertain leakages in holds and/or in interbarrier spaces, the following requirements apply:

- the above-mentioned means is to be suitable to ascertain the presence of water:
 - in holds containing type C independent tanks
 - in holds and interbarrier spaces outside the secondary barrier
- the above-mentioned means is to be suitable to ascertain the presence of liquid cargo in the spaces adjacent to cargo tanks which are not type C independent tanks.

Where the aforesaid spaces may be affected by water leakages from the adjacent ship structures, the means is also to be suitable to ascertain the presence of water.

Where the above-mentioned means is constituted by electrical level switches, the relevant circuits are to be of the intrinsically safe type and signals are to be transduced the wheelhouse and to the cargo control station, if fitted.

4 Bow or stern loading and unloading arrangements

4.1 Locations of stopping devices for cargo pumps and compressors

4.1.1 (1/6/2021)

IGC CODE REFERENCE : Ch 3, 8.7

Devices to stop cargo pumps and cargo compressors and to close cargo valves are to be fitted in a position from which it is possible to keep under control the loading/unloading manifolds.

5 Process pressure vessels and liquid, vapour and pressure piping systems

5.1 General

5.1.1 Process pressure vessels (1/6/2021)

IGC CODE REFERENCE : Ch 5, 5.1.2

Process pressure vessels handling cargo are to be considered at least as class 2 pressure vessels, in accordance with Pt C, Ch 1, Sec 3, [1.4.1].

5.1.2 Temperature of steam and heating media within the cargo area (1/6/2021)

IGC CODE REFERENCE : Ch 5, 5.1

The maximum temperature of steam and heating media within the cargo area is to be adjusted to take into account the temperature class of the cargoes.

5.2 Cargo and process piping

5.2.1 General (1/6/2021)

- a) Provisions for protection of piping against thermal stress

IGC CODE REFERENCE : Ch 5, 5.7.1, 5.11.6.4

Expansion joints are to be protected from extensions and compressions greater than the limits fixed for them and the connected piping is to be suitably supported and anchored. Bellow expansion joints are to be protected from mechanical damage.

The design and installation of expansion bellows is to be in accordance with recognized standards acceptable to the Society.

b) Segregation of high temperature piping

IGC CODE REFERENCE : Ch 5, 5.7.2

High temperature pipes are to be thermally isolated from the adjacent structures. In particular, the temperature of pipelines is not to exceed 220 °C in gas-dangerous zones.

c) Pressure relief valve setting

IGC CODE REFERENCE : Ch 5, 5.5.6 and 5.5.7

Pressure relief valves are to be set to discharge at a pressure not greater than the design pressure such that the overpressure during discharge does not exceed 110% of the design pressure.

d) Protection against leakage

IGC CODE REFERENCE : Ch 5, 5.2

Where the piping system is intended for liquids having a boiling point lower than - 30 °C, permanent means to avoid possibility of contact between leaks and hull structures are to be provided in all those locations where leakage might be expected, such as shore connections, pump seals, flanges subject to frequent dismantling, etc.

e) Means for detecting the presence of liquid cargo

IGC CODE REFERENCE : Ch 5, 5.2

The means to detect the presence of liquid cargo may be constituted by electrical level switches whose circuit is intrinsically safe. The alarm signals given by the level switches are to be transmitted to the wheelhouse and to the cargo control station, if provided.

f) Connections of relief valve discharges to cargo tanks

IGC CODE REFERENCE : Ch 5, 5.2

The connections, if any, to the cargo tanks of relief valve discharges fitted on the liquid phase cargo piping are not to be fitted with shut-off valves, but are to be pro-

vided with non-return valves in the proximity of the tanks.

g) Centrifugal pumps

IGC CODE REFERENCE : Ch 5, 5.2

Overpressure relief valves on cargo pumps may be omitted in the case of centrifugal pumps having a maximum delivery head, the delivery valve being completely closed, not greater than that permitted for the piping.

5.2.2 Scantlings based on internal pressure (1/6/2021)

a) Piping scantlings

IGC CODE REFERENCE : Ch 5, 5.11.2.2, 5.11.2.4 and 5.11.4

Piping systems are to be designed in accordance with recognized standards acceptable to the Society.

The minimum thickness is to be in accordance with recognized standards acceptable to the Society.

b) Piping subject to green seas

IGC CODE REFERENCE : Ch 5, 5.11.2.2

In particular for piping subject to green seas, the design pressure P, in bar, in the formula in 5.11.2.2 of the IGC CODE is to be replaced by an equivalent pressure P' given by the following formula:

$$P' = \frac{1}{2} \left(P + \sqrt{P^2 + 0,006R'K \frac{D_c}{D}} \right)$$

where:

D_c : External diameter of the pipe taking into account the insulation (in mm), whose thickness is to be taken at least equal to:

40 mm if D ≤ 50 mm

80 mm if D ≥ 150 mm

Intermediate values are to be determined by interpolation.

R' : Drag corresponding to the effect of green seas, in da N/m², such as given in Tab 2 as a function of the location of the pipes and of their height H (in m) above the deepest loadline; intermediate values are to be determined by interpolation.

K : permissible stress, in N/mm²

Table 2 (1/6/2021)

External diameter of pipe (1)	Aft of the quarter of the ship's length			Forward of the quarter of the ship's length		
	H ≤ 8	H = 13	H ≥ 18	H ≤ 8	H = 13	H ≥ 18
≤ 25	1500	250	150	2200	350	150
50	1400	250	150	2000	350	150
75	1100	250	150	1600	350	150
100	700	250	150	700	350	150
≥150	500	250	150	700	350	150

(1) D_c if the pipe is insulated, D otherwise.

5.2.3 Design pressure (1/6/2021)

a) Design pressure definition

IGC CODE REFERENCE : Ch 5, 5.4.1

For each piping section, the maximum pressure value among those applicable in paragraph 5.11.2.2 of the IGC Code is to be considered.

Higher and lower values of the saturated and superheated vapour pressure at 45°C may be used if agreed upon by the Society.

5.2.4 Permissible stress (1/6/2021)

a) Flanges not complying with standards

IGC CODE REFERENCE : Ch 5, 5.11.6.1, 5.11.6.2

For flanges not complying with a standard, the dimensions and type of gaskets are to be to the satisfaction of the Society.

Flanges are to be selected as to type, made and tested in accordance with the Pt C, Ch 1, Sec 10.

5.2.5 Stress analysis (1/6/2021)

a) Calculations in accordance with recognised standards

IGC CODE REFERENCE : Ch 5, 5.11.5

When such an analysis is required, it is to be carried out in accordance with the requirements listed below. Subject to this condition, calculations in accordance with recognised standards are admitted by the Society.

b) Calculation cases

IGC CODE REFERENCE : Ch 5, 5.11.5

The calculations are to be made for every possible case of operation, but only those leading to the most unfavourable results are required to be submitted.

c) Loads to be taken for calculation

IGC CODE REFERENCE : Ch 5, 5.11.5

The calculations are to be carried out taking into account the following loads:

1) piping not subject to green seas:

- pressure
- weight of the piping with insulation and internal medium
- contraction

2) piping subject to green seas that is liable to be in operation at sea and in port:

- pressure
- weight of the piping and internal medium
- green seas
- contraction
- ship motion accelerations

3) piping subject to green seas that is in operation only in port; the more severe of the following two combinations of loads:

- pressure
- weight of the piping of the internal fluid
- contraction

and

- weight of the piping
- green seas
- expansion, assuming that the thermal stresses are fully relaxed.

d) Green sea directions

IGC CODE REFERENCE : Ch 5, 5.11.5

When green seas are considered, their effects are to be studied, unless otherwise justified, in the following three directions:

- axis of the ship
- vertical
- horizontal, perpendicular to the axis of the ship. The load on the pipes is the load R' defined in [5.2.2] b).

e) Stress intensity

IGC CODE REFERENCE : Ch 5, 5.11.5

The stress intensity is to be determined as specified in the formulae in Pt C, Ch 1, Sec 10, [2.3.2] for pipes intended for high temperatures:

1) for primary stresses resulting from:

- pressure
- weight
- green seas

2) for primary stresses and secondary stresses resulting from contraction.

f) Stress intensity limits

IGC CODE REFERENCE : Ch 5, 5.11.5

1) For the first case, the stress intensity is to be limited to the lower of:

$$0,8 R_e \quad \text{and} \quad 0,4 R_m$$

2) For the second case, the stress intensity is to be limited to the lower of:

$$1,6 R_e \quad \text{and} \quad 0,8 R_m.$$

g) Piping with expansion devices

IGC CODE REFERENCE : Ch 5, 5.11.5

For piping fitted with expansion devices, their characteristics are to be submitted to the Society. Where these characteristics are such that the forces and moments at the ends of the devices are negligible for the contraction they must absorb, the calculation of the loads due to contraction in the corresponding piping is not required. It is, however, to be checked that the stress intensity corresponding to the primary stresses does not exceed the limits given in Ch 9, Sec 5, [2.5.6] f).

h) Flexibility coefficient

IGC CODE REFERENCE : Ch 5, 5.11.5

The flexibility coefficient of elbows is to be determined from the formulae given in Pt C, Ch 1, Sec 10, [2.3.2] for pipes intended for high temperatures.

i) Local stresses

IGC CODE REFERENCE : Ch 5, 5.11.5

Particular attention is to be paid to the calculation of local stresses in the assemblies subjected to axial forces and bending moments. The Society reserves the right to

request additional justifications or local strengthening where considered necessary.

j) Materials

IGC CODE REFERENCE : Ch 5, 5.12

Aluminised pipes may be fitted in ballast tanks, in inerted cargo tanks and, provided the pipes are protected from accidental impact, in hazardous areas on open deck.

For an outer pipe or duct equipped with mechanical exhaust ventilation having a capacity of at least 30 air changes per hour, the effects of both pressure and possible low temperature in the event of a high pressure line failure shall be taking into account.

k) Piping fabrication and joining details

IGC CODE REFERENCE : Ch 5, 5.8

The Society may accept relaxations, based on recognized standards, from the requirements in IGC Code, 5.8 for piping inside cargo tanks and open ended piping.

Acceptance of types of piping connections other than those mentioned in IGC Code, 5.8 may be considered by the Society case by case.

l) Welding, post-weld heat treatment and non-destructive testing

IGC CODE REFERENCE : Ch 5, 5.9

For post-weld heat treatments, the Society may waive the requirement for thermal stress relieving for pipes having a wall thickness less than 10 mm in relation to the design temperature and pressure of the concerned piping system.

For butt-welded joints of pipes not covered by IGC Code 5.9.3.2 spot radiographic controls or other non-destructive controls are to be carried out at the discretion of the Society depending upon service, position and materials.

5.3 Tests of piping components and pumps prior to installation on board

5.3.1 Valves (1/6/2021)

a) Prototype Testing

IGC CODE REFERENCE : Ch 5, 5.13

For safety valves that are subject to IGC Code para. 8.2.5, the flow or capacity are to be certified by the Society; for other types of valves, the manufacturer is to certify the flow properties of the valves based on tests carried out according to recognized standards.

For emergency shutdown valves, with materials having melting temperatures lower than 925°C, the type testing shall include a fire test to a standard acceptable to the Society.

b) Unit Production Testing

IGC CODE REFERENCE: Ch 5, 5.13

All valves are to be tested at the Manufacturer's plant in the presence of the Society's Surveyor.

Testing is to include a hydrostatic test of the valve body at a pressure equal to 1,5 times the design pressure for all valves, seat and stem leakage test at a pressure equal

to 1,1 times the design pressure for valves other than safety valves. In addition, cryogenic testing consisting of valve operation and leakage verification for a minimum of 10% of each type and size of valve for valves other than safety valves intended to be used at a working temperature below -55°C. The set pressure of safety valves is to be tested at ambient temperature.

For valves used for isolation of instrumentation in piping not greater than 25 mm, unit production testing need not be witnessed by the surveyor. Records of testing are to be available for review.

As an alternative to the above, if so requested by the relevant Manufacturer, certification of a valve may be issued subject to the following:

- the valve has been approved as required in a) for valves intended to be used at a working temperature below -55°C, and
- the Manufacturer has a recognised quality system that has been assessed and certified by the Society subject to periodical audits, and
- the quality control plan contains a provision to subject each valve to a hydrostatic test of the valve body at a pressure equal to 1,5 times the design pressure for all valves and seat and stem leakage test at a pressure equal to 1,1 times the design pressure for valves other than safety valves. The set pressure of safety valves is to be tested at ambient temperature. The Manufacturer is to maintain records of such tests, and
- cryogenic testing is performed, in the presence of the Society's representative, consisting of valve operation and leakage verification for a minimum of 10% of each type and size of valve for valves other than safety valves intended to be used at a working temperature below -55°C.

5.3.2 Cargo Pumps (1/6/2021)

a) Prototype Testing

Each size and type of pump is to be approved through design assessment and prototype testing. Prototype testing is to be witnessed in the presence of the Society's Surveyor. In lieu of prototype testing, satisfactory in-service experience of an existing pump design approved by a QSCS Classification Society submitted by the Manufacturer may be considered.

Prototype testing is to include a hydrostatic test of the pump body equal to 1,5 times the design pressure and a capacity test. For submerged electric motor driven pumps, the capacity test is to be carried out with the design medium or with a medium below the minimum working temperature. For shaft driven deep well pumps, the capacity test may be carried out with water. In addition, for shaft driven deep well pumps, a spin test to demonstrate satisfactory operation of bearing clearances, wear rings and sealing arrangements is to be carried out at the minimum design temperature. The full length of shafting is not required for the spin test, but must be of sufficient length to include at least one bearing and sealing arrangements. After completion of tests, the pump is to be opened out for examination.

b) Unit Production Testing

All pumps are to be tested at the Manufacturer's plant in the presence of the Society's Surveyor. Testing is to include a hydrostatic test of the pump body equal to 1,5 times the design pressure and a capacity test. For submerged electric motor driven pumps, the capacity test is to be carried out with the design medium or with a medium below the minimum working temperature. For shaft driven deep well pumps, the capacity test may be carried out with water.

As an alternative to the above, if so requested by the relevant Manufacturer, the certification of a pump may be issued subject to the following:

- the pump has been approved as required in a) and
- the Manufacturer has a recognised quality system that has been assessed and certified by the Society subject to periodical audits, and
- the quality control plan contains a provision to subject each pump to a hydrostatic test of the pump body equal to 1,5 times the design pressure and a capacity test. The Manufacturer is to maintain records of such tests.

5.4 Cargo system valving requirements

5.4.1 Cargo tank connections for gauging (1/6/2021)

a) Exemption

IGC CODE REFERENCE : Ch 5, 5.5.5

The requirements in paragraph 5.5.5 of the IGC Code relevant to cargo tank connections for pressure gauges and measuring devices do not apply to tanks with an MARVS not exceeding 0,07 MPa.

5.4.2 Emergency shutdown (1/6/2021)

a) Clarification on location of fusible elements

IGC CODE REFERENCE : Ch 18, 18.10

The cargo stations in way of which the fusible elements mentioned in paragraph 18.10.3.2 of the IGC Code are to be fitted are to be intended as the loading and unloading manifolds.

5.5 Cargo transfer methods

5.5.1 Discharge into common header (1/6/2021)

IGC CODE REFERENCE : Ch 5, 5.6

When two or more pumps located in different cargo tanks are operating at the same time discharging into a common header, the stopping of the pumps is to activate an alarm at the centralised cargo control location.

5.6 Bonding

5.6.1 Static electricity (1/6/2021)

a) Acceptable resistance

IGC CODE REFERENCE : Ch 5, 5.7.4

To avoid the hazard of an incentive discharge due to the build-up of static electricity resulting from the flow of the liquid/gases/vapours, the resistance between any point on the surface of the cargo and slop tanks, piping

systems and equipment, and the hull of the ship is not to be greater than $10^6 \Omega$.

b) Bonding straps

IGC CODE REFERENCE : Ch 5, 5.7.4

Bonding straps are required for cargo and slop tanks, piping systems and equipment which are not permanently connected to the hull of the ship, for example:

- 1) independent cargo tanks
- 2) cargo tank piping systems which are electrically separated from the hull of the ship
- 3) pipe connections arranged for the removal of the spool pieces.

Where bonding straps are required, they are to be:

- 1) clearly visible so that any shortcoming can be clearly detected
- 2) designed and sited so that they are protected against mechanical damage and are not affected by high resistivity contamination, e.g. corrosive products or paint
- 3) easy to install and replace.

5.7 Integrated cargo and ballast system

5.7.1 General (1/6/2021)

The requirements for integrated cargo and ballast systems are given in Ch 7, Sec 4, [3.5].

6 Cargo tank venting system

6.1 Pressure relief systems

6.1.1 Cargo tank (1/6/2021)

a) Size of pressure relief devices

IGC CODE REFERENCE : Ch 8, 8.4.1.2 and Figure 8.1

For application of the formula in paragraph 8.4.1.2 of the IGC Code, the following is to be applied for prismatic tanks:

- L_{min} , for non-tapered tanks, is the smaller of the horizontal dimensions of the flat bottom of the tank. For tapered tanks, as would be used for the forward tank, L_{min} is the smaller of the length and the average width.
- For prismatic tanks whose distance between the flat bottom of the tank and bottom of the hold space is equal to or less than $L_{min}/10$:
 A = external surface area minus flat bottom surface area.
- For prismatic tanks whose distance between the flat bottom of the tank and bottom of the hold space is greater than $L_{min}/10$:
 A = external surface area.

6.1.2 Interbarrier spaces (1/6/2021)

a) Protection of interbarrier spaces

IGC CODE REFERENCE : Ch 8, 8.2.2

- 1) The formula for determining the relieving capacity given in b) is developed for interbarrier spaces sur-

rounding independent type A cargo tanks, where the thermal insulation is fitted to the cargo tanks.

- 2) The relieving capacity of pressure relief devices of interbarrier spaces surrounding independent type B cargo tanks may be determined on the basis of the method given in b); however, the leakage rate is to be determined in accordance with 4.7.2 of the IGC Code.
 - 3) The relieving capacity of pressure relief devices for interbarrier spaces of membrane and semi-membrane tanks is to be evaluated on the basis of specific membrane/semi-membrane tank design.
 - 4) The relieving capacity of pressure relief devices for interbarrier spaces adjacent to integral type cargo tanks may, if applicable, be determined as for type A independent cargo tanks.
- b) Size of pressure relief devices

IGC CODE REFERENCE : Ch 8, 8.4

The combined relieving capacity (in m³/s) of the pressure relief devices for interbarrier spaces surrounding type A independent cargo tanks where the insulation is fitted to the cargo tanks may be determined by the following formula:

$$Q_{sa} = 3,4 \cdot A_C \cdot \frac{\rho}{\rho_v} \cdot \sqrt{h}$$

where:

Q_{sa} : Minimum required discharge rate of air in standard conditions of 273 K and 1.013 bar

A_C : Design crack opening area in (m²)

$$A_C = \frac{\pi}{4} \cdot \delta \cdot l$$

with:

δ : Max. crack opening width in (m)
 $\delta = 0,2 \cdot t$

t : Thickness of tank bottom plating in (m)

l : Design crack length in (m) equal to the diagonal of the largest plate panel of the tank bottom (see Fig 1)

h : Max. liquid height above tank bottom plus 10 × MARVS in (m)

ρ : Density of product liquid phase in kg/m³ at the set pressure of the interbarrier space relief device

ρ_v : Density of product vapour phase in kg/m³ at the set pressure of the interbarrier space relief device and a temperature of 273 K.

MARVS : max allowable relief valve setting of the cargo tank (bar)

6.1.3 Vents (1/6/2021)

IGC CODE REFERENCE : Ch 8, 8.2.10

The height of vent exits as indicated in paragraph 8.2.10 of the IGC Code is also to be measured above storage tanks and cargo liquid lines, where applicable.

6.1.4 Segregation of vents (1/6/2021)

a) Additional requirements on vent location

IGC CODE REFERENCE : Ch 8, 8.2.11.1 and 8.2.11.2

- 1) The distances of the vent exits are to be measured horizontally.
- 2) In the case of carriage of flammable and/or toxic products, the vent exits are to be arranged at a distance of at least 5 m from exhaust ducts and at least 10 m from intake ducts serving cargo pump rooms and/or cargo compressor rooms.
- 3) The distances are also intended to refer to outlets of ventilation ducts of safe spaces.

Figure 1 : Determination of I (1/6/2021)

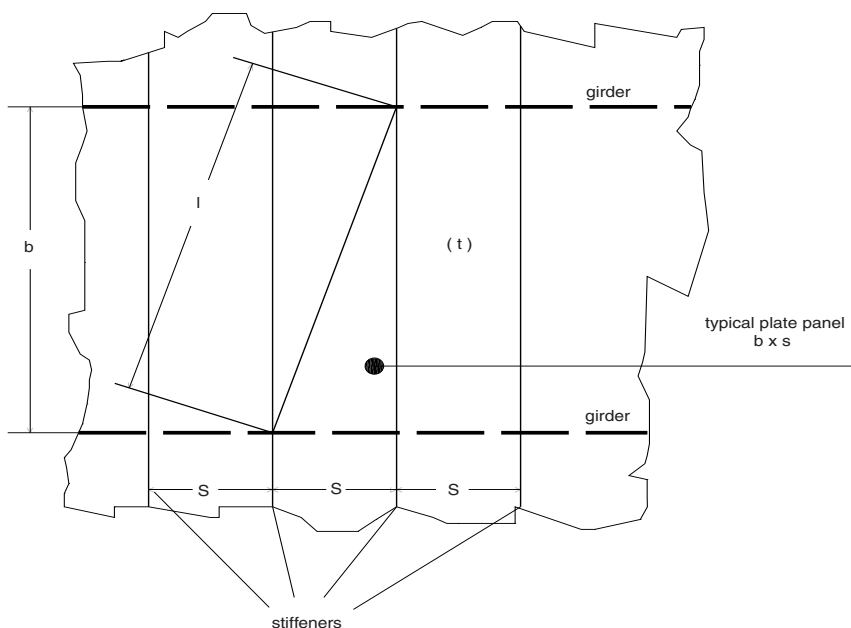

6.2 Additional pressure relieving system for liquid level control

6.2.1 Tank filling limits (1/6/2021)

IGC CODE REFERENCE : Ch 13, 13.3.2

The words 'to prevent the tank from becoming liquid full' in paragraph 13.3.2 of the IGC Code have the following meaning:

At no time during the loading, transport or unloading of the cargo including fire conditions will the tank be more than 98% liquid full, except as permitted by 15.4.1 of the IGC Code. These requirements, together with those of 8.2.17 of the IGC Code, are intended to ensure that the pressure relief valves remain in the vapour phase.

7 Environmental control

7.1 Inerting

7.1.1 General (1/6/2021)

a) Dew point

IGC CODE REFERENCE : Ch 9, 9.4.1

As far as the IGC Code requirements relevant to the dew point are concerned, the following additional provisions apply:

- 1) where cargo tank insulation is not protected from water vapour penetration by means of an effective vapour barrier, accepted by the Society, the maximum value of the dew point is to be less than the design temperature

- 2) where cargo tank insulation is protected by an effective vapour barrier, accepted by the Society, the maximum value of the dew point is to be less than the minimum temperature which may be found on any surface within the spaces filled with dry inert gas or dry air
- 3) the temperature of the hull structures adjacent to cargo tanks is not to become lower than the minimum permissible working temperature, specified in Ch 9, Sec 6, for the steel grade employed for such hull structures.

b) Precautions against fire

IGC CODE REFERENCE : Ch 9, 9.4.1

Precautions are to be taken to minimise the risk that static electricity generated by the inert gas system may become a source of ignition.

7.2 Inert gas production on board

7.2.1 Exemptions (1/6/2021)

IGC CODE REFERENCE : Ch 9, 9.5

- a) Inert gas generating systems are to be considered as essential services and are to comply with the applicable Sections of the Rules, as far as applicable.
- b) Where, in addition to inert gas produced on board, it is possible to introduce dry air into the above-mentioned spaces, where this is acceptable depending on the type of cargo tank adopted, or to introduce inert gas from a supply existing on board, it is not necessary that standby or spare components for the inert gas system are kept on board.

8 Mechanical ventilation in the cargo area

8.1 Spaces required to be entered during normal cargo handling operations

8.1.1 Ventilation duct arrangement (1/6/2021)

IGC CODE REFERENCE : Ch 12, 12.1.5

- a) Ventilation ducts to gas-dangerous spaces are to be fitted with metallic shut-off dampers provided with "open" and "closed" signs. These dampers are to be arranged in the open, in a readily accessible position.
- b) Gas-dangerous spaces for the purpose of a) are those mentioned in paragraph 12.1.1 of the IGC Code. For other spaces which are gas-dangerous only due to their position, some relaxation may be granted.

8.1.2 Recirculation prevention (1/6/2021)

IGC CODE REFERENCE : Ch 12, 12.1.5

- a) Exhaust ducts from gas-dangerous spaces are to be arranged at a distance in the horizontal direction of at least 10 m from ventilation outlets of gas-safe spaces. Shorter distances may be accepted for ventilation outlets from safe spaces protected by air-locks.
- b) Intakes of gas-dangerous spaces are to be arranged at a distance in the horizontal direction of at least 3 m from ventilation intakes and outlets and openings of accommodation spaces, control stations and other gas-safe spaces.
- c) Exhaust and intake ducts for the same gas-dangerous space, or for the same space rendered safe by an air-lock, are to be arranged at a distance from each other in the horizontal direction of not less than 3 m.

8.1.3 Additional requirements for non-sparking fans (1/6/2021)

- a) Non-sparking fans

IGC CODE REFERENCE : Ch 12, 12.1.7

- 1) A fan is considered as non-sparking if in both normal or abnormal conditions it is unlikely to produce sparks.
 - 2) The air gap between the impeller and the casing is to be not less than 0,1 of the shaft diameter in way of the impeller bearing and not less than 2 mm. It need not be more than 13 mm.
- b) Materials for non-sparking fans
- IGC CODE REFERENCE : Ch 12, 12.1.7
- 1) The impeller and the housing in way of the impeller are to be made of materials as per list in the Code, with a production certificate.
 - 2) Electrostatic charges both in the rotating body and the casing are to be prevented by the use of anti-static materials. Furthermore, the installation on board of the ventilation units is to be such as to ensure their safe bonding to the hull.

- 3) The following impellers and housings are considered as sparking and are not permitted:

- impellers of an aluminium alloy or magnesium alloy and a ferrous housing, regardless of tip clearance
- housing made of an aluminium alloy or a magnesium alloy and a ferrous impeller, regardless of tip clearance
- any combination of ferrous impeller and housing with less than 13 mm design tip clearance.

- c) Type test for non-sparking fans

IGC CODE REFERENCE : Ch 12, 12.1.7

Type tests on the finished product are to be carried out in accordance with the requirements of the Society or an equivalent national or international standard.

- d) Motor shafting

IGC CODE REFERENCE : 12, 12.1.7

The shafting penetration of motors driving fans through bulkheads and decks of dangerous spaces or through ventilation ducts is to be fitted with a gas-tight sealing device, of the oil-seal type or equivalent, deemed suitable by the Society.

8.2 Spaces not normally entered

8.2.1 General requirements (1/6/2021)

- a) Minimum number of air changes

IGC CODE REFERENCE : 12, 12.2

Both fixed and portable systems are to guarantee the efficient ventilation of such spaces in relation to the relative density, in respect of the air, and to the toxicity of the gases transported. The type of portable fans and their connection to the spaces served are to be approved by the Society. In no case are portable electrical fans acceptable.

9 Instrumentation (Gauging, Gas detection)

9.1 General

9.1.1 Cargo tank instrumentation (1/6/2021)

The instrumentation is to be of a type approved by the Society.

9.1.2 Detection of leak through secondary barrier (1/6/2021)

IGC CODE REFERENCE : Ch. 13, 13.7.1

Upon special approval, appropriate temperature indicating devices may be accepted by the Society instead of gas detecting devices when the cargo temperature is not lower than - 55 °C.

9.1.3 Indicator location (1/6/2021)

Monitoring list

IGC CODE REFERENCE : Ch. 13, 13.1.2

The following information and alarms are to be concentrated in the positions specified in this requirement.

a) The following is to be transduced to the "cargo control room" and the "control position" as defined in 3.4.1 of the IGC Code:

- 1) the indication signalling the presence of water and/or liquid cargo in holds or interbarrier spaces
- 2) the cargo heater low temperature alarm
- 3) the alarm signalling the presence of liquid cargo in the vent main as per 5.2.2.4 of the IGC Code
- 4) the indication of the hull temperature and the hull structure low temperature alarm required in 13.7.2.2 of the IGC Code
- 5) the alarm signalling the automatic shutdown of electrically driven submerged pumps required in 10.2.9 of the IGC Code
- 6) the indication of the cargo level and the cargo tank high level alarm required in 13.3.1 of the IGC Code
- 7) the indication of the vapour space pressure and the vapour space pressure gauges of each cargo tank and associated high and low pressure alarms required in 13.4.1 of the IGC Code
- 8) the gas detection equipment alarm required in 13.6.13 of the IGC Code
- 9) the cargo compressor high temperature alarm required in 17.4.2.2 of the IGC Code
- 10) the alarm for automatic shutdown of the cargo compressor for high pressure or high temperature, as required in 17.16.4.4 of the IGC Code.

When the cargo system is not remote controlled and therefore the aforesaid "control positions" are not required, the above-mentioned controls, information and alarms are to be located in a suitable, easily accessible location.

If this position is an enclosed space, it is to comply with the requirements of 3.4 of the IGC Code. This position should preferably be located in the wheelhouse.

b) Independently of the above, the following is to be transduced to the wheelhouse:

- 1) the alarm signalling the presence of water and/or liquid cargo in holds or interbarrier spaces
- 2) the cargo heater low temperature alarm
- 3) the alarm signalling the presence of liquid cargo in the vent main as per 5.2.2.4 of the IGC Code
- 4) the indication of the pressure value in the vapour space of each cargo tank mentioned in 13.4.1 of the IGC Code; such indication is to give the setting pressure value of the relief valve and the minimum

allowable pressure value in the cargo tank concerned

- 5) the high pressure and low pressure alarms, when required, for cargo tanks as per 13.4.2 of the IGC Code
 - 6) the hull structure low temperature alarm required in 13.7.2.2 of the IGC Code
 - 7) the gas detection equipment alarm required in 13.6.13 of the IGC Code
 - 8) the cargo compressor high temperature alarm required in 17.4.2.2 of the IGC Code
 - 9) the alarm for automatic shutdown of the cargo compressor for high pressure or high temperature, as required in 17.16.4.4 of the IGC Code.
- c) Where the cargo control room is located within the accommodation spaces and is readily accessible, the alarms in b) may be grouped in a single audible and visual alarm except for the indication and alarms in 4), 5) and 7), which are to be independent from each other.
- d) The high level and high or low pressure audible and visual alarms for cargo tanks as per 13.3.1 to 13.3.3 and 13.4.1 to 13.4.3 of the IGC Code and the alarm signalling the presence of liquid in the vent main are to be located in such a position as to be clearly heard and identifiable by the personnel in charge of loading operation control.

9.2 Level indicators for cargo tanks

9.2.1 General (1/6/2021)

IGC CODE REFERENCE : Ch. 13, 13.2.1 and 13.2.2

a) In order to assess whether or not one level gauge is acceptable, the wording "can be maintained" is to be interpreted to mean that any part of the level gauge other than passive parts can be overhauled while the cargo tank is in service.

Passive parts are those parts assumed not subject to failures under normal service conditions.

b) Where level gauges containing cargo are arranged outside the tank they serve, means are to be provided to shut them off automatically in the event of failure.

9.3 Overflow control

9.3.1 Overflow alarm and shutdown (1/6/2021)

a) Shut-off valve for overflow control

IGC CODE REFERENCE : Ch. 13, 13.3.2

The sensor for automatic closing of the loading valve for overflow control may be combined with the liquid level indicators required by paragraph 13.2.1 of the IGC Code.

b) Shut-off valve closing time

IGC CODE REFERENCE : Ch. 13, 13.3.1 to 13.3.3

The closing time of the valve referred to in 13.3.2 in seconds (i.e. time from shutdown signal initiation to complete valve closure) is to be not greater than:

$$\frac{3600 \cdot U}{LR}$$

where:

- U : Ullage volume at operating signal level (m³)
LR : Maximum loading rate agreed between ship and shore facility (m³/h)

The loading rate is to be adjusted to limit surge pressure on valve closure to an acceptable level taking into account the loading hose or arm, and the ship and shore piping systems, where relevant.

9.4 Pressure gauges

9.4.1 Pressure gauges in cargo tanks (1/6/2021)

IGC CODE REFERENCE : Ch. 13, 13.4.1

The low pressure alarm indicated in paragraph 13.4.1 of the IGC Code is also to be located in the cargo control room.

9.5 Temperature indicating devices

9.5.1 Temperature recording (1/6/2021)

IGC CODE REFERENCE : Ch. 13, 13.5.1

The temperatures are to be continuously recorded at regular intervals. Audible and visual alarms are to be automatically activated when the hull steel temperature approaches the lowest temperature for which the steel has been approved.

9.6 Gas detection requirements

9.6.1 Gas measurements (1/6/2021)

In addition to the provisions of [9.6.2] to [9.6.3], the fitting of gas measuring equipment is subject to the those of Pt C, Ch 4, Sec 1, [5.2.4] b).

9.6.2 Position of sampling heads (1/6/2021)

IGC CODE REFERENCE : Ch. 13, 13.6.12

Sampling heads in cargo holds are not to be located in positions where bilge water may collect.

9.6.3 Gas sampling lines (1/6/2021)

IGC CODE REFERENCE : Ch. 13, 13.6.8

Gas sampling lines are to be located outside accommodation spaces, unless they are fitted within gas-tight pipes.

9.6.4 Protected spaces (1/6/2021)

IGC CODE REFERENCE : Ch. 13, 13.6.2

In addition to the list in paragraph 13.6.2 of the IGC Code, the gas detection system is also to serve spaces adjacent to pump rooms and compressor rooms.

9.6.5 Portable gas detectors (1/6/2021)

IGC CODE REFERENCE : Ch. 13, 13.6.19

For ships intended to carry toxic and flammable gases, two sets for toxic gases and two sets for flammable gases are to be provided.

10 Special requirements

10.1 Materials for construction

10.1.1 (1/6/2021)

IGC CODE REFERENCE : Ch. 17, 17.2

Materials "exposed to cargo" are those constituting systems, cargo appliances or arrangements which are in contact with (liquid or vapour) cargo in normal operating conditions.

10.2 Inhibition

10.2.1 Polymerisation prevention - Alternative requirement (1/6/2021)

IGC CODE REFERENCE : Ch. 17, 17.8.1

- a) As an alternative to the addition of inhibited liquid, it may be accepted that, at the end of each refrigeration period, the liquid is completely removed from the refrigeration system by means of vapour from compressors or by means of inert gas. In such case, the following wording is to be entered on the Certificate of Fitness:

"At the end of each refrigeration period, the liquid is to be completely removed from the refrigeration system by means of vapour from compressors or by means of inert gas."

- b) On the cargo compressor delivery side, a temperature switch is to be fitted, set at a suitable temperature, depending on the characteristics of the product carried (e.g. 60°C for butadiene), giving a visual and audible alarm on the navigation bridge and in the cargo control station, if any, which causes the compressor to stop when such temperature is exceeded.

10.3 Chlorine

10.3.1 Cargo containment system (1/6/2021)

- a) Relief valves

IGC CODE REFERENCE : Ch. 17, 17.13.1.4

Chlorine discharge from pressure relief valves is to be led to an absorption device deemed suitable by the Society.

10.3.2 Cargo piping system (1/6/2021)

- a) Piping design and fabrication

IGC CODE REFERENCE : Ch. 17, 17.13.2.2

A welding neck type flange deemed suitable is shown in Fig 2 as an example.

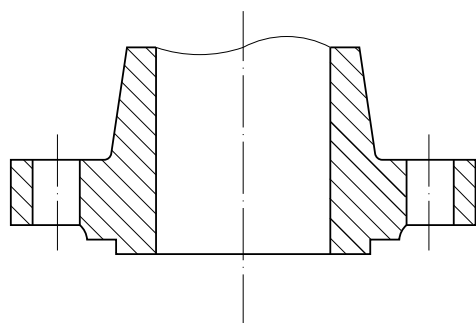
Figure 2 : Suitable neck type flange**10.3.3 Instrumentation - Safety devices (1/6/2021)**

a) Gas detection system

IGC CODE REFERENCE : Ch. 17, 17.13.4.3

The gas detection system is to be permanently installed.

10.3.4 Protection of personnel (1/6/2021)

a) Additional equipment

IGC CODE REFERENCE : Ch. 17, 17.13.5

In addition to the source of uncontaminated air, two complete and independent air breathing apparatuses, not employing oxygen supplies, each having a capacity of at least 1200 litres of non-compressed air and two sets of protective equipment, complete with gas-tight boots, gloves and eye protection, are to be provided. The above-mentioned equipment and clothing are to be kept in the space indicated in paragraph 17.13.5 of the IGC Code and are additional to those required in other parts of this Chapter.

10.3.5 Filling limits for cargo tanks (1/6/2021)

IGC CODE REFERENCE : Ch. 17, 17.13.6.1

When determining the filling limits of the cargo tanks for the transport of chlorine, the effect of the refrigeration plant is not to be considered.

11 Personnel protection requirements for individual products**11.1 Showers and eyes wash****11.1.1 (1/6/2021)**

IGC CODE REFERENCE : Ch 14, 14.4.3

The showers and eyes wash are to be fitted with a heating system, or other suitable installation, in order to avoid any ice formation in their piping.

12 Summary of minimum requirements**12.1 Additional information on products****12.1.1 (1/6/2021)**

IGC CODE REFERENCE - CHAPTER 19

Table 3 lists some additional information for those products which are listed in the table in Chapter 19 of the IGC Code. The list shown in Table 3 gives properties for pure products. The specific gravity to be taken into account for the design of a ship might be altered considering the actual properties of the commercial product.

Information on temperature classes and explosion groups for electrical equipment in connection with the products to be carried is indicated in Sec 8, Tab 4.

Table 3 (1/6/2021)

Product name	Boiling temperature (°C)	Specific gravity at boiling point (kg/m ³)	Ratio vapour/air density
Acetaldehyde	20,8	780	1,52
Ammonia, anhydrous	- 33,4	680	0,60
Butadiene	- 4,5	650	1,87
Butane	-0,5/11,7	600	2,02
Butylenes	- 6,3/- 7	625	1,94
Chlorine	- 34	1560	2,49
Diethyl ether	34,6	640	2,55
Dimethylamine	6,9	670	1,55
Ethane	- 88,6	549	1,04
Ethyl chloride	12,4	920	2,22
Ethylene	- 104	570	0,97
Ethylene oxide	-10,7	870	1,52
Isoprene	34,5	680	2,35
Isopropylamine	32,5	700	2,03
Methane (LNG)	-161,5	420	0,55
Methyl bromide	4,5	1730	3,27
Methyl chloride	-23,7	1000	1,78
Monoethylamine	16,6	690	1,56
Nitrogen	-196	808	0,97

Pt E, Ch 19, Sec 5

Product name	Boiling temperature (°C)	Specific gravity at boiling point (kg/m ³)	Ratio vapour/air density
Pentanes (all isomers)	36,1	610	2,6
Pentene (all isomers)	30,1/37	610	2,6
Propane	-42,3	580	1,56
Propylene	-47,7	610	1,50
Propylene oxides	34,5	860	2.00
Refrigerant gases			
Dichlorodifluoromethane (R12)	-30	1486	4,26
Dichloromonofluoroethane (R21)	8,9	1480	3,9
Dichlorotetrafluoroethane (R114)	3,8	1510	1,31
Monochlorodifluoromethane (R22)	-42	1420	2,98
Monochlorotetrafluoroethane (R124)	-	-	4,70
Monochlorotrifluoromethane (R13)	-81,4	1520	3,60
Sulphur dioxide	-10	1460	2,3
Vinyl chloride	-13,9	970	2,15
Vinyl ethyl ether	35,5	754	2,50
Vinylidene chloride	31,7	1250	3,45

SECTION 6

ADDITIONAL REQUIREMENTS FOR MACHINERY AND CARGO SYSTEMS OF BARGE-LNG BUNKER

1 General

1.1 Application

1.1.1 (1/6/2021)

These units are to comply with the requirements of Sec 5.

The requirements in this Section are additional to the ones in Sec 5.

Units complying with the requirements of this Section will be granted the additional service feature **LNG bunker** which may be complemented by one or more of the following:

- **IG-Bunker (Inert Gas Bunker)**, where the barge-LNG bunker is designed to also supply inert gas, to ensure gas freeing and aeration, to a LNG fuelled ship.
- **BT (Bunker Trust)** where the barge-LNG bunker is designed with arrangement for the verification of the LNG quality and quantity delivered to the receiving ship.
- **VCS-Bunker (Vapour Control System Bunker)** where the barge-LNG bunker is designed with systems for control of vapour emission from cargo tanks from receiving ship during bunkering.

1.2 Scope

1.2.1 (1/6/2021)

This Section addresses:

- the design and installation of the piping system of the barge-LNG bunker intended to transfer LNG to the LNG fuelled ship and the vapour transfer system to/from these units.
- the safety arrangements.

1.2.2 (1/6/2021)

Units intended to load, carry and transfer gases other than LNG will be considered on a case by case basis, and the Society reserves the right to establish additional requirements.

2 Definitions

2.1 Bunker emergency shut-down system (ESD)

2.1.1 (1/12/2020)

A bunker ESD is a system that safely and effectively stops the transfer of LNG (and vapour as applicable) between the

receiving ship and the bunker ship in the event of an emergency during the bunkering operation, and puts the system in a safe condition.

2.2 Bunkering connections

2.2.1 (1/12/2020)

Bunkering connections correspond to the end of the fixed piping of the barge-LNG bunker (i.e. manifold for a system with flexible hose and before the swivel for a system with transfer arm).

2.3 Custody Transfer Measuring system

2.3.1 (1/12/2020)

Custody transfer Measuring system in fluid measurement is a metering point (location) where the fluid is being measured for sale from one party to another.

2.4 Emergency release coupling (ERC) or breakaway coupling (BRC)

2.4.1 (1/6/2021)

A breakaway coupling or emergency release coupling (ERC) is a coupling located in the LNG transfer system (at one end of the transfer system, either the receiving ship end or the barge-LNG bunker end, or in the middle of the transfer system), which separates at a predetermined section when required, each separated section containing a self-closing shut-off valve, which seals automatically.

An emergency release coupling can be activated:

- by external forces applied to the predetermined section exceeding a predetermined value, and/or
- by manual, remote or automatic control, in case of emergency.

2.5 ESD link system or Ship-ship link (SSL)

2.5.1 (1/6/2021)

ESD link system or Ship-ship or ship-shore link (SSL) is a communication system to transmit ESD signals and other signals between two different ESD systems (ship to shore/ship or vice versa) via compatible system technologies such as pneumatic, electric, fiber-optic or radio telemetry.

2.6 LNG bunkering station

2.6.1 (1/6/2021)

LNG bunkering station means the following equipment and the area where they are fitted:

- bunkering connections (see [2.2]) for hoses and piping used for liquid and vapour return lines,
- isolating valves and emergency shut-down valves,
- drip trays, draining arrangement and other arrangements such as water curtain intended for the protection of the ship structure from cold leakages,
- gas detection system through thermal camera or gas detectors for enclosed space,
- bunkering system ESD indication,
- inerting and purging system connections,
- pressure relieving system for the Bunkering manifold.

2.7 LNG transfer system

2.7.1 (1/6/2021)

A LNG transfer system is a system used to connect the barge-LNG bunker and the receiving ship in order to transfer LNG or both LNG and vapours.

The LNG transfer system includes:

- loading arms and transfer hoses, as applicable
- manifold including valves and instrumentation,
- QCDC,
- breakaway coupling (BRC) or Emergency release coupling (ERC),
- isolation flanges.

2.8 MID

2.8.1 (1/6/2021)

Measuring Instruments Directive (MID). The Measuring Instruments Directive (MID) for Custody Transfer metering for liquids, is the European directive law that sets down the essential requirements for a wide range of measuring instruments. It provides options for the manufacturer as to how the requirements are met and which organizations to apply to for conformity assessment.

2.9 OIML R117-1

2.9.1 (1/6/2021)

OIML R117-1 is a recommendation issued by the ORGANISATION INTERNATIONALE DE METROLOGIE LEGALE (OIML). The International Organization of Legal Metrology (OIML) is a worldwide, intergovernmental organization whose primary aim is to harmonize the regulations and

metrological controls applied by the national metrological services, or related organizations, of its Member States. R117-1 addresses the Dynamic measuring systems for liquids other than water.

2.10 Pendant

2.10.1 (1/6/2021)

Pendant (for ESD system) is a portable device provided by one ship to another ship or shore terminal or provided by the shore to the ship for the manual tripping of its ESD system by the other party in the absence of a compatible ship-ship link (SSL).

2.11 Quick connect and disconnect coupling (QCDC)

2.11.1 (1/6/2021)

A QCDC is a manual or powered mechanical device used to connect the LNG transfer system to the receiving ship manifold. The coupling consists of a Nozzle (male) and a receptacle (female). The nozzle allows quick connection and disconnection of the fuel supply hose to the receptacle, mounted on the LNG manifold.

2.12 Safety zone

2.12.1 (1/6/2021)

The safety zone is a zone around the barge-LNG bunker, the bunkering station of the receiving ship and the LNG transfer system, where the only activities to be performed are the bunkering operations and related activities and where safety measures are taken to cope with a possible leakage of LNG or vapour.

2.13 Transfer arm

2.13.1 (1/6/2021)

Transfer arm refers to any system allowing supporting transfer hoses or rigid pipes during bunkering operations.

3 Document to be submitted

3.1 General

3.1.1 (1/6/2021)

The drawings and related information to be submitted are listed in Tab 1.

3.1.2 (1/6/2021)

The operating manuals and procedures to be submitted are listed in Tab 2.

Table 1 : Documents to be submitted (1/6/2021)

No	A/I	Documents
1	A	Arrangement of the ship showing the location of the bunkering station and bunkering control station
2	I	Risk assessment report including operational constraints for the bunkering operation such as minimum visibility, day/night, maximum wind and wave, weather condition
3	I	List of all bunkering equipment with their technical specification (including hoses)
4	A	Details of LNG transfer system and vapor return line system
5	A	Purging and Inerting system supplying inert gas to the bunker station and bunkering equipment
6	I	Custody Transfer Measuring Instruments system (Including evidence of approval according to MID or OIML R117-1 requirements)
7	A	ESD Bunkering Concept including cause and effect matrix
8	A	Block diagram of Control, Monitoring and Safety System
9	A	ESD link system (SSL) description and list of communication devices used for the bunkering operation with their specification
10	A	Drip trays and water curtain arrangement
11	I	Instrumentation list and relevant Safety certificates for electrical equipment located in hazardous areas and concerning the bunkering, where applicable
12	A	Drawings of transfer arm
13	I	Fender and mooring arrangement for bunkering operation with mooring analysis
14	A	Bunkering station manifold specification and drawings, with strength calculation including values of maximum allowable working pressure and allowable loads at manifold flange
15	A	Access and walkway arrangement to bunkering station
Note 1: A = to be submitted for approval I = to be submitted for information		

Table 2 : Operating manuals and procedures to be submitted (1/6/2021)

No	A/I	Documents
1	I	Operational manual including bunkering procedure (with details of maximum allowable bunkering flow and maximum allowable working pressure), all information required in IGF Code 18.4.2 and IGC Code 18.2 and procedure for the boil off gas and vapour return management
2	I	Bunkering Safety Checklist according to IGF Code 18.4.3
3	I	Safety Zones Layout for the bunkering operation
4	I	Maintenance and storage instruction manual for the bunkering equipment
Note 1: A = to be submitted for approval I = to be submitted for information		

4 General design requirements

4.1 Risk Assessment

4.1.1 LNG transfer system (1/6/2021)

A risk assessment shall be conducted according to IGC Code 1.1.11 and IGF Code 4.2 as far as applicable.

The goal of the risk assessment is to identify all safety, environmental and asset hazards associated to the LNG Transfer

system during bunkering operation and their possible mitigation where required. The risk analysis can be of qualitative or semi-quantitative type and shall be based on international recognized standards and Tasneef Guide for Risk Analysis.

4.1.2 (1/6/2021)

The risk assessment is to be performed using the most appropriate techniques such HAZID (Hazards Identification), FMEA (Failure Mode and Effect Analysis) or HAZOP

(Hazard and Operability study) as far as applicable and at least the following items shall be assessed:

- Bunkering station including manifold arrangement
- ESD Bunkering System
- Bunkering Equipment
- ESD Link system (SSL)
- Voice communication System between barge-LNG bunker and receiving ship
- Monitoring, Control and Safety System of bunkering operation
- Fender and mooring arrangement

taking into account the following operations:

- Arrival, approach and mooring of barge-LNG bunker close to the receiving ship
- Connection and testing of LNG transfer system including ESD system and communication link
- LNG bunkering procedure (including hose handling, hose connection, gassing up, cooling down)
- LNG bunkering in parallel with other activities (SIMOPs)
- Disconnection of the LNG bunker hose in normal and emergency condition (including draining, purging and inerting).

4.1.3 (1/6/2021)

The SIMOPs shall be defined with reference to international recognized standards or guidelines such as IACS Rec. 142, SGMF FP08-01 "Simultaneous Operations (SIMOPS) during LNG Bunkering" and other activities identified by the risk assessment experts considering the expected port operations of the receiving ship.

4.2 Hazardous area

4.2.1 General (1/6/2021)

In general, safety and security zones are to comply with IACS Rec. 142, Section 2 and they are to be addressed during the risk assessment for the LNG bunkering operation.

4.2.2 (1/6/2021)

In addition to the hazardous areas in accordance with IGC Code, the following are to be included:

- LNG bunkering station and 3 m beyond these, up to a height of 2,4 m above the deck
- areas on the open deck within spillage coamings surrounding LNG bunkering connections and manifold valves and 3 m beyond these, up to a height of 2,4 m above the deck
- when applicable, transfer arm operating area extended by 3 m on either direction.

4.3 Materials

4.3.1 (1/6/2021)

Materials used in LNG transfer systems, piping system for liquefied gas and other systems or components in contact with LNG or gas are to be in accordance with IGC Code, Chapter 6.

4.4 Arrangement of bunkering system

4.4.1 LNG bunkering station (1/6/2021)

The LNG bunkering station is to be located on open deck so that sufficient natural ventilation is provided. Closed or semi-enclosed bunkering stations will be subject to special consideration and are subject to risk assessment as specified in [4.1]. Access to closed or semi-enclosed bunkering station from other closed or semi-enclosed space shall be granted via airlock.

The LNG bunkering station when not located in the cargo area shall be separated from accommodation and control stations through gas tight divisions and the layout is subject to risk assessment.

LNG bunkering station may be accepted at the ship bow and stern provided that the relevant requirements of IGC Code 3.8 are complied with.

The maximum allowable loads are to be indicated on a warning plate fitted on the manifold or nearby.

The manifold shall be arranged at least with the following instruments and fittings:

- Pressure gauge
- Pressure transmitter
- Temperature gauge
- Temperature transmitter
- Sampling point for gas detection
- Safety relief valve fitted in between the presentation flange and ESD bunkering valve.

4.4.2 Drip trays and protection of ship hull (1/6/2021)

Drip trays are to be fitted below the liquid bunkering connections and where leakage may occur which can cause damage to the ship structure.

Thermal sensors are to be positioned in the drip trays.

The drip trays are to be made of stainless steel and can be drained overboard.

When LNG boiling point at atmospheric pressure is lower than design temperature of the hull steel, a water piping system is to be fitted, providing a low-pressure water curtain in way of the hull under the bunkering manifold for additional protection of the hull steel and the ship's structure; other solutions will be considered on a case by case basis.

The operating platforms in way of the manifold operating position are to be fitted with raised gratings made of a material suitable for the LNG boiling point at atmospheric pressure.

4.4.3 Bunkering control station (1/6/2021)

Control of the bunkering operation should be possible from a bunkering control station that is placed in a safe location with regards to bunkering operations. The bunkering control station may be within the cargo control room. At this location, overfilling alarm and automatic and manual shut-down are to be indicated.

Unobstructed direct or camera view of the LNG bunkering station is to be available from the Bunkering control station.

An LNG system schematic/piping and instrumentation diagram (P&ID) shall be reproduced and permanently mounted in the bunkering control station.

4.4.4 LNG Transfer Systems (1/6/2021)

The manifold for transfer of liquid shall be fitted with manually operated stop valve and a remotely/automatically operated valve (ESD valve) fitted in series.

The LNG transfer system is to include at least an emergency release coupling (ERC) and an insulation flange. A Quick Connect Disconnect Coupling (QCDC) may be installed together with above mentioned components.

The ERC is to be fitted on the receiving ship side, but may be accepted also fitted on LNG transfer system side provided that the relevant scenario is considered during the risk analysis required in [4.1].

In case the ERC is fitted on the LNG transfer system side, the nearest pressure relief valve on the receiving ship shall have sufficient capacity to accommodate the trapped liquid in the bunkering hose or pipe.

The hoses are to be adequately supported and protected to prevent potential damage or sparks in the event of activation of the ERC.

The manifolds are to be capable to withstand the allowable loads as defined in an international recognized standard or guideline such as SGMF TGN-06-04 "Technical Guidance Manifold" or equivalent.

The LNG transfer system is to be designed to avoid the release of gas to the atmosphere during bunkering operations.

The bunkering transfer rate is to be capable of being controlled to match with the capabilities and requirements of the receiving ship.

The maximum LNG transfer rate is to be declared and justified, taking into consideration:

- The management of the BOG generated during bunkering operation
- The temperature of the LNG supplied to the ship
- The maximum flow permitted by the ERC and or break away coupling
- The maximum flow permitted by the hose
- The maximum flow permitted by the QCDC
- The maximum allowable working pressure of the receiving ship bunkering station.

The GAS/LNG velocity in the piping system is not to exceed 10 m/s in order to avoid the generation of static electricity and to limit the heat transfer due to friction inside the pipes; higher velocity may be considered provided they are duly justified.

In order to prevent cryogenic liquid spills, the design of the transfer system is to be such that the lines can be drained and purged by nitrogen after a normal or emergency disconnection.

Any pipeline or component containing liquid, which may be isolated due to the ESD activation, is to be provided with pressure relief valve.

4.4.5 LNG Bunkering ESD system (1/6/2021)

A bunkering ESD system is to be installed in addition to the ESD required by IGC Code, if a separate transfer system is provided.

All electrical components of the ESD systems are to be of suitable safe type taking into account the hazard categorization of the area where they are located.

4.4.6 Lighting (1/6/2021)

Lighting shall illuminate the bunker station area, and if installed in a hazardous area should be compliant with applicable hazardous area equipment requirements. Lighting shall adequately illuminate the bunkering operation work area as follows:

- LNG bunker hose(s),
- Connection and couplings on both receiving ship and bunkering facility,
- ESD system call points,
- Communication systems,
- Fire-fighting equipment,
- Passage ways / gangways intended to be used by the personnel in charge of the bunkering operation, and
- Vent mast(s).

4.5 Mooring and fendering

4.5.1 (1/6/2021)

Steel to steel contact between barge-LNG bunker and receiving ship e.g. via mooring lines, ladders, gangways, chains for fender support etc. shall be avoided through the use of insulation. Bunker hoses/pipes shall be supported and isolated to prevent electrical contact with the receiving ship.

4.5.2 (1/6/2021)

The rubber fenders used for keeping the distance between the barge-LNG bunker and receiving ship shall be built according to an international recognized standard such as ISO 17357-2 or equivalent. The dimensions and arrangement of fenders shall be verified during risk assessment as required in [4.1] taking into consideration the interferences of the hazardous areas of both ships and the minimum bend radius of the bunkering hose.

5 Hoses and pumps

5.1 Hose design requirements

5.1.1 General (1/6/2021)

The hoses used for bunkering are to comply with the requirements in IGC Code 5.11.7.

For bunkering hoses the following characteristics are to be defined by the designer and submitted to the Society:

- Minimum/Maximum Allowable Working Temperature
- Maximum Allowable Working Pressure
- Minimum Bend Radius
- Maximum Allowable Crush Load
- Maximum Allowable Axial Load.

5.1.2 Hose Maximum Working Pressure and Strength (1/6/2021)

The maximum working pressure specified by manufacturer is not to be less than 1 MPa in accordance with IGC Code 5.11.7.3.

The strength of the hoses is to be compatible with the maximum release forces of the ERC.

5.1.3 Materials (1/6/2021)

All materials of hose assembly are to be suitable for marine environment, compatible with each other and with the fluid conveyed (LNG and LNG vapours).

5.1.4 End connection and coupling (1/6/2021)

The end fittings are to be made of corrosion resistant material and in accordance with IGC Code Table 6.4.

5.2 Type approval, testing and certification of LNG bunkering hoses

5.2.1 (1/6/2021)

Bunkering hoses are to be type approved by the Society.

Flexible hoses intended for the handling of LNG are to be in compliance with design and testing requirements standards EN1474-2, or EN21012 or equivalent standards and IGC Code 5.11.7.

5.2.2 (1/6/2021)

All hoses are to be individually certified by the Society at satisfactory outcome of testing according to [5.3], carried out by the manufacturer in the presence of a Society Surveyor, unless an alternative certification scheme is agreed with the Society.

5.3 Testing of Hoses at workshop

5.3.1 Pressure test (1/6/2021)

Each hose assembly is to be subjected to a hydraulic pressure test at ambient temperature to a pressure not less than 1,5 times the maximum operating (nominal) pressure, to demonstrate that the hose assembly is capable of withstanding pressure without leaking.

5.3.2 Non destructive testing of welding (1/6/2021)

Welds of the hose assembly are to be subjected to non destructive testing (NDT) according to international recognized standards.

5.4 Hoses documentation

5.4.1 (1/6/2021)

A hose technical file containing the following information is to be kept on board:

- Hose identification number
- Type approval certificate issued by Society
- Product test certificate issued by Society
- Overall weight of the hose and end fittings assembly
- Date of entry into service
- Inspection intervals and lifetime
- Instructions for the handling, storage and installation of hose

5.5 Marking of products

5.5.1 (1/6/2021)

Each hose is to be permanently marked according to a recognized international standard or the following information:

- Manufacturer's name or logo
- Hose designation and size
- Maximum Allowable Working Pressure
- Maximum and minimum allowable working temperature
- Date of manufacture
- Marking from Society

5.6 Transfer pumps

5.6.1 (1/6/2021)

The transfer pumps if different from cargo pumps shall comply with requirements specified in Ch 9, Sec 5, [3.2] and they shall be type approved.

All pumps are to be pressure tested in the presence of the Surveyor.

6 Quick connect disconnect coupler (QCDC)

6.1 Type approval, testing and certification of QCDC

6.1.1 (1/6/2021)

QCDC are to be type approved by the Society.

6.1.2 (1/6/2021)

All QCDC are to be individually certified by the Society at satisfactory outcome of testing according to [6.3] carried out by the manufacturer in the presence of the Surveyor, unless an alternative certification scheme is agreed with the Society.

6.2 Type testing

6.2.1 (1/6/2021)

The QCDC is to be subjected to a type test to confirm the release performance under ice built up condition according to an international recognized standard such as ISO 21593, ISO 16904 or equivalent.

6.3 Workshop testing

6.3.1 Pressure test (1/6/2021)

The QCDC is to be subjected to a hydrostatic pressure test, at ambient temperature, to a pressure not less than 1,5 times the Maximum Allowable Working Pressure to demonstrate that the QCDC is capable of withstanding pressure without leakage.

7 Emergency release coupling (ERC)

7.1 Type approval, testing and certification of QCDC

7.1.1 General (1/6/2021)

Transfer arms and hoses shall be fitted with an emergency release coupling (ERC) designed to minimize the release of LNG on emergency disconnection. The emergency release coupling is to be designed as breakaway coupling i.e. with automatic disconnection in case the allowable loads of manifold as defined in [4.4.4] are exceeded. Additionally the emergency release coupling may be designed with manual or remote and automatic activation by the ESD bunkering system.

7.1.2 (1/6/2021)

Each separate section is to contain a self-closing shut-off valve, which seals automatically on disconnection.

7.1.3 (1/6/2021)

All electrical components of the emergency release coupling are to be certified of a suitable safe type.

When applicable, the availability of power to the ERC is to be monitored and arranged so that bunkering operation is automatically stopped in case of loss of power supply to the ERC.

7.1.4 (1/6/2021)

The bunkering line is to be designed and arranged to withstand the surge pressure that may result from the activation of the ERC.

7.2 Type approval, testing and certification of ERC

7.2.1 (1/12/2020)

ERC are to be type approved by the Society.

7.2.2 (1/12/2020)

All ERCs are to be individually certified by the Society at satisfactory outcome of testing according to [7.4] carried out by the manufacturer in the presence of a Society Surveyor, unless an alternative certification scheme is agreed with the Society.

7.3 Type testing

7.3.1 (1/12/2020)

The ERC are to be subjected to a type test according to an international recognized standard such as ISO 18683 or equivalent to confirm the values of axial and shear forces at which it automatically separates. Additionally the tightness of the self-closing shut-off valves after separation is to be tested.

7.3.2 (1/12/2020)

The ERC are to be subjected to a type test to confirm the release performance under ice built up condition.

7.3.3 (1/12/2020)

When applicable, the ERC is to be subjected to a type test to confirm the release in case of remote or automatic activation.

7.4 Workshop testing

7.4.1 Pressure test (1/12/2020)

The ERC are to be subjected to a hydrostatic pressure test, at ambient temperature, to a pressure not less than 1,5 times the Maximum operating (nominal) pressure, to demonstrate that the ERC are capable of withstanding pressure without leaking.

8 Electrical insulation flanges

8.1 General

8.1.1 (1/6/2021)

Each insulation flange is to be subjected to a test of electrical resistance in air and the resistance is to be of at least 1000 Ω but less than 1 M Ω .

8.1.2 (1/6/2021)

The resistance of each insulation flange is to be measured after installation in the complete LNG transfer system and the resistance is to be not less than 1000 Ω .

9 Hose Supports and transfer arms

9.1 General

9.1.1 (1/6/2021)

Hoses are to be suitably supported in such a way that the minimum allowable bending radius is complied with.

9.1.2 (1/6/2021)

Arrangements such as cranes or winches are to be available for the handling of hoses whose size or weight does not allow a safe manual handling.

9.1.3 (1/6/2021)

Non electrical equipment located in hazardous area and belonging to items such as cranes, winches, etc. is to be suitable for explosive atmosphere according to international recognized standard (e.g. ISO 80079-36 or equivalent).

9.1.4 (1/6/2021)

Electrical equipment located in hazardous area is to comply with IGC Code 10.2.

9.2 Transfer arms

9.2.1 (1/6/2021)

Transfer arms are to be approved by the Society.

9.2.2 (1/6/2021)

Transfer arms are to be designed and constructed in accordance with a recognized national or international standards acceptable to the Society as EN1474-1.

9.2.3 (1/6/2021)

The maximum allowable operating amplitude and forces acting on the loading arm during the bunkering operations are to be defined and compatible with the hoses and ERC. The exceeding of transfer arm envelope is to activate two stages alarms in bunker control station and on the navigation bridge.

The initiation of the first stage is to activate a visual and audible alarm.

The initiation of the second stage is to activate the ESD and ERC system.

9.2.4 (1/12/2020)

All transfer arms are to be individually certified by the Society at satisfactory outcome of tests, as required for lifting appliances and operational tests, or per recognized international standards, carried out by the manufacturer in the presence of a Society Surveyor, unless an alternative certification scheme is agreed with the Society.

9.2.5 (1/6/2021)

The operational test per [9.2.4] is to give evidence of compliance with the design criteria per [9.2.3].

10 Inert Gas System

10.1

10.1.1 (1/6/2021)

An inert gas system is to be fitted on board, to enable purging and inerting of the bunkering lines; the system is to be in compliance with IGC Code 9.4 and 9.5.

10.1.2 (1/6/2021)

The inerting capacity is to be designed according the bunkering operations and when based on inert gas storage on board, the capacity is not to be less than 5 times the volume of the hose and pipes to be purged.

11 Gas detection

11.1 Gas detection in enclosed spaces

11.1.1 (1/6/2021)

Permanently installed gas detectors are to be fitted in all hazardous areas including bunkering station if of enclosed or semi-enclosed type, LNG process room and other enclosed spaces containing LNG piping or other equipment not equipped with double walled piping.

11.1.2 (1/6/2021)

The number of detectors in each space is to be considered taking into account the size, layout and ventilation of the space. At least two independent gas detectors are required in each hazardous area.

11.1.3 (1/6/2021)

The detection equipment is to be located where gas may accumulate and in the ventilation outlets. Gas dispersion analysis or a physical smoke test is to be used to find the best arrangement.

11.1.4 (1/6/2021)

An audible and visual alarm is to be activated before the vapour concentration reaches 30% of the lower explosive limit (LEL).

11.1.5 (1/6/2021)

Audible and visual alarms from the gas detection equipment are to be located on the bridge and in the bunkering control station.

11.2 Gas detection in open spaces

11.2.1 (1/6/2021)

The installation of thermal imaging camera is to be evaluated on the basis of the risk assessment as defined in [4.1], for open spaces classed as hazardous areas (e.g. bunkering station, hose handling areas).

Monitoring of thermal imaging camera is to be available in the bunkering control station.

12 Control and safety systems

12.1 General

12.1.1 (1/6/2021)

Appropriate segregation shall be maintained between control, monitoring/alarm and safety functions to limit the effects of single failures during bunkering.

Failure of one part of the integrated system shall not affect the functionality of other parts, except for those functions directly dependent on the defective part.

Being the bunkering control system combined with the cargo control system all relevant requirements specified in the IGC Code 13.9 are to be complied with.

12.2 Emergency shut-down systems (ESD)

12.2.1 (1/6/2021)

An ESD system is to be fitted to safely and effectively stop the transfer of LNG (and vapour as applicable) between the receiving ship and the bunkering ship in the event of an emergency during the bunkering operation and in general it is to be in compliance with IGC Code 18.10.

The ESD safety system is to be designed so as to limit the consequence of failures. It is to be constructed on the fail-to safety principle.

The ESD system is to be of the self-check type; as a rule, failure within the ESD including the outside connection, is to activate an alarm.

The control systems involved in the ESD, which is a linked system to allow both parties (on board receiving ship and the barge-LNG bunker) to shut down the transfer in an emergency situation, is to be capable of being activated automatically or manually.

The ESD system normally includes two stages:

- ESD-stage 1, a stage in which the LNG transfer process is shut down in a controlled manner
- ESD-stage 2, a stage in which decoupling of the transfer system between the transfer vessels or between a vessel and an LNG port facility is activated.

The ESD-1 and ESD-2 logic shall be verified and agreed among stakeholders during the risk assessment as required in [4.1] also considering applicable international recognized standard or guidelines (e.g. SIGTTO ESD Arrangements & Linked Ship/Shore Systems for Liquefied Gas Carriers).

Where provided, override command of ESD system has to be clearly indicated in the Bunkering control station.

The ESD-1 and ESD-2 trips are to trigger visual and audible alarms in the navigation bridge, engine control room, cargo and bunkering control room and manifold area.

12.2.2 (1/6/2021)

At least one local manual activation position for the ESD system is to be made available for the LNG fueled ship being bunkered, this may be in the form of an ESD System pendant with sufficient length of cable or an ESD link system (SSL ship/shore link or ship/ship link). The SSL may be various type (e.g.: electric, fibre-optic, radio telemetry, pneumatic). The SSL is to have an adequate reliability and redundancy level according to a recognized international standard or guideline (e.g.: SIGTTO ESD Arrangements & Linked Ship/Shore Systems for Liquefied Gas Carriers).

12.2.3 (1/6/2021)

At least one local manual activation position for the ESD system is to be fitted in a place that have a clear view of the manifold area (the 'clear view' may be provided via CCTV) but is at a safe distance from the manifold.

12.2.4 (1/6/2021)

Any activation of the ESD systems is to be implemented simultaneously on both bunkering facility and receiving ship.

12.2.5 (1/6/2021)

The timing sequence is to ensure that the involved pumps and compressors (if any) stop before the complete closure of any manifold valve.

12.2.6 (1/6/2021)

The bunkering lines are to be designed and arranged to withstand the surge pressure that may result from the activation of the emergency release coupling and quick closing of ESD valves. If not demonstrated to be required at a higher value due to pressure surge considerations, a default time of 5 seconds from the trigger of the alarm to full closure of the ESD valves is to be arranged.

12.2.7 (1/6/2021)

The components of the ESD system located in hazardous and safety zones are to be of a suitable safe type.

12.2.8 (1/6/2021)

LNG bunker transfer should not be resumed until the transfer system and associated safety systems (fire detection, etc.) are returned to normal operation condition.

12.2.9 (1/6/2021)

All electrical components of the emergency release coupling actuator and of the ESD systems that are provided by the barge-LNG bunker are to be approved and certified by the Society.

12.3 Alarms and safety actions

12.3.1 (1/6/2021)

The alarms and safety function/actions required for the transfer system are given in Tab 3 and they are additional to those required in the IGC Code Table 18.1. The extent of alarms and safety functions may be reconsidered on the basis of outcome from risk assessment.

The receiving ship is expected to be capable of transmitting at least an ESD signal via an hardwired system.

Table 3 : Alarms and safety actions required for the transfer system (1/6/2021)

Parameters	Alarm	Activation of the Bunker ESD systems (ESD-1)	Automatic activation of the emergency release coupling (ESD-2) (1)
Fire Detection in way of tank domes or manifold area for receiving ship and barge-LNG bunker (1)	X	X	
Shutdown signal from shore or receiving ship	X	X	
Loss of ESD linked system (1)	X	X	
Loss of power supply to LNG bunkering control system	X	X	
ESD logic failure	X	X	
Low Pressure in cargo valve remote control system	X		
Low Low Pressure in cargo valve remote control system	X	X	
Stop of the ventilation of enclosed or semi-enclosed bunkering station	X	X	
Loss of actuating power to the common loading arm maneuvering system or to the ERC of individual loading arms	X	X	
High level in surge drum (where provided)	X		
High High level in surge drum (where provided)	X	X	
Low pressure in the supply cargo tank	X		
Low Low pressure in the supply cargo tank	X	X	
(1) when the receiving ship is equipped with an SSL compatible with the barge-LNG bunker SSL			

Parameters	Alarm	Activation of the Bunker ESD systems (ESD-1)	Automatic activation of the emergency release coupling (ESD-2) (1)
Sudden pressure drop at the transfer pump discharge	X	X	
High level in the LNG storage tank of receiving ship (1)	X		
High High level in the LNG storage tank of receiving ship (1)	X	X	
High pressure in the LNG storage tank of receiving ship (1)	X		
High High pressure in the LNG storage tank of receiving ship (1)	X	X	
High pressure in the manifold vapor return system	X		
High high pressure in the manifold vapor return system	X	X	
High pressure in the manifold liquid supply system	X		
High High pressure in the manifold liquid supply system	X	X	
LNG cold leakage in the manifold drip tray	X	X	
Gas detection in bunkering station of receiving ship (1)	X	X	
Gas detection in bunkering station of bunkering ship	X	X	
Excessive movement of ship from berth/ship	X	X	X
Disconnection of the ERC	X	X	
(1) when the receiving ship is equipped with an SSL compatible with the barge-LNG bunker SSL			

12.4 Communication systems

12.4.1 (1/6/2021)

A two-way voice communication system is to be provided between the barge-LNG bunker and the receiving ship.

12.4.2 (1/6/2021)

The components of the communication system located in hazardous and safety zones are to be of a suitable safe type.

13 Testing of the LNG transfer system at workshop

13.1 Pressure test

13.1.1 (1/6/2021)

All piping and tanks the LNG transfer system are to be subjected to a hydraulic pressure test in the presence of a Society Surveyor, at ambient temperature, to a pressure not less than 1,5 times the nominal pressure, to demonstrate the capability to withstand pressure without leaking.

13.2 Inspection of welds

13.2.1 (1/6/2021)

When applicable, the welds of the LNG transfer system are to be subjected to a non-destructive testing and all butt

welds are to be subjected to a 100% radiographic or ultrasonic examination.

14 Testing and trials of the LNG transfer system at yard

14.1

14.1.1 (1/6/2021)

After assembly on board, the following tests and trials are to be carried out in the presence of a Surveyor.

14.2 Piping leak test

14.2.1 (1/6/2021)

A leak test, using air or other suitable medium, of the completely assembled and equipped LNG transfer and vapour return systems, in steps of 10-20% up to 90% of the operational pressure of the LNG/gas system is to be carried out in the presence of a Society Surveyor, to detect leakage with soap/leak detection spray. Holding time is depending of the volume/part of the installation being Leak tested.

14.3 Inerting

14.3.1 (1/6/2021)

Inerting of the total LNG/gas system including LNG storage tank(s), following the approved inerting procedure.

15 Implementation survey

15.1

15.1.1 (1/6/2021)

Upon issuance of the additional service feature LNG bunker, a dedicated survey is to be carried out on occasion of the first LNG bunkering, as follows:

- a) The first LNG bunkering is to be carried out according to the relevant LNG bunkering procedure.
- b) During the survey the following is to be carried out:
 - Examination of transfer piping systems including supporting arrangements.
 - Verification of satisfactory operation of:
 - Control and monitoring systems
 - Connections systems (QCDC).
 - ESD system
 - piping purging and inerting systems.

16 Additional features

16.1 IG-Bunker (Inert Gas Bunker)

16.1.1 General (1/6/2021)

The additional feature **IG-Bunker (Inert Gas Bunker)** is assigned to barge-LNG bunker designed to also supply inert gas to a LNG fuelled ship to ensure inerting of the receiving ship systems, and complying with the following requirements.

16.1.2 Inert Gas system (1/6/2021)

The inert gas system is to comply with IGC Code 9.4 and 9.5 and Chapter 9.

16.1.3 Piping system (1/6/2021)

The lines used for the inert gas are to be independent from the LNG liquid and vapour lines used for normal operation.

16.1.4 Document to be submitted (1/6/2021)

The following documents are to be submitted to the Society for approval in addition to the information required in [3]:

- Diagram of the Inert gas system
- Procedure for supplying inert gas to the receiving ship.

16.2 BT (Bunker Trust)

16.2.1 General (1/6/2021)

The additional feature **BT (Bunker Trust)** is assigned to barge-LNG bunker designed with arrangement for the verification of the LNG quality and quantity delivered to the receiving ship according to international recognized standard (e.g. ISO 23306) or equivalent or according to a gas fuel specification agreed among the stakeholders.

16.2.2 Documents to be submitted (1/6/2021)

The following documents are to be submitted to the Society for approval in addition to the information required in [3]:

- Diagram of the LNG sampling arrangement
- Technical specification of LNG analyzer
- LNG Sampling procedure
- Evidence of approval of the measuring system according to MID or OIML R117-1.

16.2.3 Sampling System (1/6/2021)

The unit has to be fitted with a sampling system in accordance with international recognized standard (e.g. ISO 8943) or equivalent. Other type of system or piping arrangement are subject to special consideration and they are evaluated case by case.

The sampling connections shall be in compliance with requirements specified in IGC Code 5.6.5.

The sampling procedure shall be in compliance with requirements specified in IGC Code 18.9 and included in the risk assessment as required in [4.1.2].

The LNG analyzer is to be type approved.

16.2.4 Custody Transfer Measuring System (1/6/2021)

A Custody Transfer Measuring System is to be installed on the barge-LNG bunker.

A recognized third party should approve the design and instruments against MID or OIML R117-1; evidence of this is required to be supplied to the Society.

16.3 VCS-Bunker (Vapour Control System Bunker)

16.3.1 General (1/6/2021)

The additional feature **VCS-Bunker (Vapour Control System Bunker)** is assigned to barge-LNG bunker in compliance with Pt F, Ch 13, Sec 7 for the assignment of notation **VCS-Transfer**.

16.3.2 Vapour return handling (1/6/2021)

The barge-LNG bunker is to be capable of handling all or part of the vapours from receiving ship generated during the LNG bunkering operation, in addition to its own boil-off gas (BOG), without release to the atmosphere. The vapour handling capacity of the barge-LNG bunker is to be indicated and justified.

Different ways to dispose of the vapours may be considered, such as:

- re-liquefaction
- utilization by the gas consuming equipment of the barge-LNG bunker (e.g. gas or dual-fuel engines or boilers)
- gas combustion unit.

A combination of these means is possible and other solutions may be accepted if they are duly justified to the Society.

SECTION 7

ADDITIONAL REQUIREMENTS FOR MACHINERY AND CARGO SYSTEMS OF BARGE-CHEMICAL

1 General

1.1 Application

1.1.1 (1/6/2021)

These units are to comply with the requirements of Sec 3.

The requirements in this Section are additional to the ones in Sec 3.

These units are to comply with the requirements of the latest version of the International Code for the Construction and Equipment of Ships Carrying Dangerous Chemicals in Bulk (IBC Code), as amended, as specified in Ch 8, [1.1.1] to [1.1.3].

The requirements in this chapter applicable to barge-chemical apply to units intended to carry products listed in the table in Chapter 17 of the IBC Code. For the carriage of products listed in the table in Chapter 18 of the IBC Code and products not at present listed in either of the tables in Chapter 17 or Chapter 18 of the IBC Code, the Society reserves the right to establish specific requirements.

The requirements of this Section supplement those of the IBC Code.

All the requirements of this Section are cross referenced to the applicable Chapters, Sections or paragraphs of the IBC Code, as appropriate.

1.2 Documents to be submitted

1.2.1 (1/6/2021)

The documents listed in Tab 1 are to be submitted for approval.

1.3 Exemptions

1.3.1 (1/6/2021)

The requirements in Pt C, Ch 1, Sec 10, [11.4.1] b) do not apply to service tanks.

The requirements in Pt C, Ch 1, Sec 10, [11.4.6] a) do not apply.

Table 1 : Documents to be submitted (1/6/2021)

No.	A/I	Document
1	I	List of products to be carried, including maximum vapour pressure, maximum liquid cargo temperature and other important design conditions
2	A	Ventilation duct arrangement in gas-dangerous spaces and adjacent zones
3	A	General layout of cargo pump room with details of: - bulkhead penetrations - gas detection system - other alarms and safety arrangement
4	A	Diagram of the cargo tank venting system with: - indication of the outlet position - details of the pressure/vacuum valves and flame arrestors - details of the draining arrangements, if any
5	A	Diagram of the cargo tank cleaning system
6	A	Diagram of the cargo heating systems
7	A	Diagram of inert gas system with details of the inert gas plant
8	A	Plans and calculations of safety relief valves
9	A	Details of cargo handling, including arrangements and details of piping and fittings
10	A	Details of cargo pumps
11	A	Details of process pressure vessels and relative valving arrangement
12	A	Bilge and ballast system in cargo area
13	A	Gas freeing system in cargo tanks including inert gas system
14	A	Ventilation system in cargo area

No.	A/I	Document
15	A	Gas detection system
16	A	Cargo tank instrumentation
17	I	Loading and unloading operation description, including cargo tank filling limits, where applicable

Note 1: A = to be submitted for approval in four copies
I = to be submitted for information in duplicate
Diagrams are also to include, where applicable, the (local and remote) control and monitoring systems and automation systems.

2 Cargo pump rooms

2.1 Machinery driven by shafting passing through pump room bulkheads

2.1.1 (1/6/2021)

IBC CODE REFERENCE : Ch 3, 3.3.7

- Bulkhead or deck penetrations of cargo pump rooms, or of pump rooms intended for runs of shafts driving pumps and/or fans, are to be provided with gas-tight sealing devices to the satisfaction of the Society.
- Lubrication or other means of ensuring permanence of gas-tightness of the above-mentioned sealing devices is to be arranged in such a way that it can be checked from outside the cargo pump room.

3 Fuel tanks in cargo area

3.1 Definition

3.1.1 (1/6/2021)

Cargo tank block is the part of the ship as indicated in Fig 1 extending from the aft bulkhead of the aftmost cargo or slop tank to the forward bulkhead of the forward most cargo or

slop tank, extending to the full depth and beam of the ship, but not including the area above the deck of the cargo or slop tank.

3.2 Location of fuel tanks in cargo area

3.2.1 (1/6/2021)

- These requirements apply to chemical tankers carrying toxic (see Note 1) liquid cargoes.
- Fuel tanks located with a common boundary to cargo or slop tanks shall not be situated within nor extend partly into the cargo tank block. Such tanks may, however, be situated aft and/or forward of the cargo tank block.
- They may be accepted when located as independent tanks on open deck in the cargo area subject to spill and fire safety considerations.
- The arrangement of independent fuel tanks and associated fuel piping systems, including the pumps, can be as for fuel tanks and associated fuel piping systems located in the machinery spaces. For electrical equipment, requirements to hazardous area classification must however be met.

Note 1: toxic liquid cargoes include those for which toxic vapour detection is specified in column "k" of the table of chapter 17 of the IBC Code.

Figure 1 (1/6/2021)

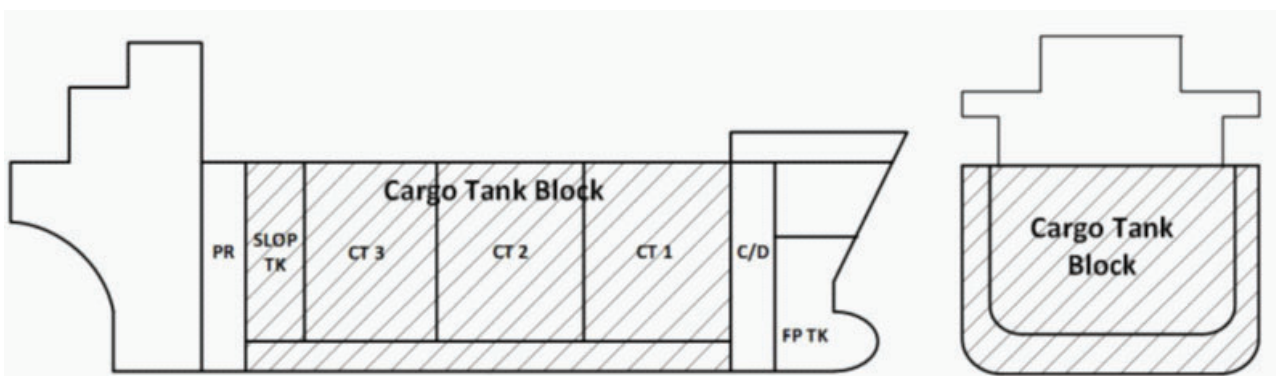

4 Bilge and ballast arrangements

4.1 Ballast segregation

4.1.1 Eductors (1/6/2021)

IBC CODE REFERENCE : Ch 3, 3.5.1

An eductor situated in the cargo area using water power from pumps in the machinery spaces may be accepted as a means to discharge permanent ballast from tanks and/or double bottoms adjacent to cargo tanks, provided the supply line is above deck level and a non-return valve and removable spool piece are fitted in the supply line outside the machinery space (see Fig 2).

Figure 2 : Discharge arrangement (1/6/2021)

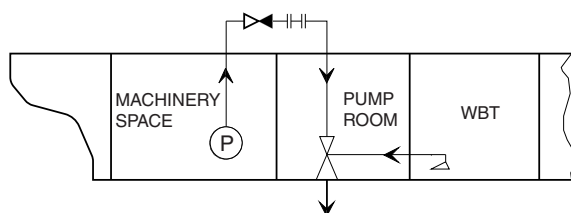

4.2 Ballast filling arrangement

4.2.1 Clarification (1/6/2021)

IBC CODE REFERENCE : Ch 3, 3.5.2

The filling of cargo tanks with ballast may be performed at deck level by means of pumps serving permanent ballast tanks, as specified in IBC Code 3.5.2, provided that a removable spool piece or flexible hose plus a shut-off valve are fitted on the inlet to the cargo tank. The shut-off valve is in addition to the required non-return valve. Consideration is to be given to the arrangement of the in-tank piping and the possible creation of static electricity (see Fig 2).

4.3 Bilge

4.3.1 Arrangement (1/6/2021)

IBC CODE REFERENCE : Ch 3, 3.5.3

The relaxation relevant to the bilge system for spaces which are separated from cargo tanks by a double bulkhead is to be understood as limited to spaces not enclosing piping which may contain cargo.

4.3.2 Use of cargo pumps as bilge pumps (1/6/2021)

IBC CODE REFERENCE : Ch 3, 3.5.3

- Cargo pumps may also be used as bilge pumps provided they are connected to the bilge piping through a shut-off valve and a non-return valve arranged in series.
- In the case of carriage of corrosive liquids, one of the cargo pumps, as specified in IBC Code 3.5.3, may be used for bilge service provided it is connected to the bilge piping through two shut-off valves plus a non-return valve arranged in series.
- In cargo pump rooms of ships carrying toxic or corrosive products, suitable means for conveying spills from cargo pumps and valves to collecting trays are to be fitted. Trays may also consist of part of the pump room bottom, suitably bounded and protected against the corrosive action of products. Spills may be disposed of by means of suitable pumps or eductors. In the case of carriage of mutually incompatible products, the above-mentioned means for collecting and disposing of spills are to be different and separated from each other.

5 Piping systems other than cargo piping system

5.1 General

5.1.1 Materials (1/6/2021)

- Materials are to comply with the provisions of Pt C, Ch 1, Sec 10.
- Spheroidal graphite cast iron may be accepted for bilge and ballast piping.

5.1.2 Independence of piping systems (1/6/2021)

Fuel oil systems are to:

- be independent from the cargo piping system
- have no connections with pipelines serving cargo or slop tanks.

5.1.3 Passage through cargo tanks and slop tanks (1/6/2021)

- Unless otherwise specified, bilge, ballast and fuel oil systems serving spaces located outside the cargo area are not to pass through cargo tanks or slop tanks. They may pass through ballast tanks or void spaces located within the cargo area.
- Where expressly permitted, ballast pipes passing through cargo tanks are to fulfil the following provisions:
 - they are to have welded or heavy flanged joints the number of which is kept to a minimum
 - they are to be of extra-reinforced wall thickness as per Pt C, Ch 1, Sec 10, Tab 5
 - they are to be adequately supported and protected against mechanical damage.

5.2 Bilge system

5.2.1 Draining of spaces located outside the cargo area (1/6/2021)

For bilge draining of spaces located outside the cargo area, refer to Pt C, Ch 1, Sec 10, [6].

5.2.2 Draining of pump rooms (1/6/2021)

- Arrangements are to be provided to drain the pump rooms by means of power pumps or bilge ejectors.

Note 1: On units of less than 500 gross tonnage, the pump rooms may be drained by means of hand pumps with a suction diameter of not less than 50 mm.

- Cargo pumps or stripping pumps may be used for draining cargo pump rooms provided that:
 - a screw-down non-return valve is fitted on the bilge suction, and
- Bilge pipe internal diameter is not to be less than 50 mm.
- High liquid level in the bilges is to activate an audible and visual alarm in the cargo control room and on the navigation bridge.

5.2.3 Drainage of hold spaces, cofferdams and void spaces located within the cargo area (1/6/2021)

Hold spaces, cofferdams and void spaces located within the cargo area and not intended to be filled with water ballast are to be fitted with suitable means of drainage.

5.3 Ballast system

5.3.1 General (1/6/2021)

- a) Every unit is to be provided with segregated ballast tanks
- b) The capacity of the segregated ballast tanks is to be considered by the Society on a case-by-case basis. In general, the capacity of segregated ballast tanks is to be at least such that, in any ballast condition at any part of the voyage, including the conditions consisting of light-weight plus segregated ballast only, the ship's draught and trim satisfy minimum and maximum values deemed reasonable by the Society
- c) Except where expressly permitted, ballast systems serving segregated ballast tanks are to be completely separated from the cargo and fuel oil systems
- d) In the unit of 150 gross tonnage and above, no ballast water is normally to be carried in any fuel oil tank; see Pt C, Ch 1, Sec 10, [7.1.3].

5.3.2 Pumping arrangements for ballast tanks within the cargo area (1/6/2021)

Segregated ballast tanks located within the cargo area are to be served by two different means. At least one of these means is to be a pump or an eductor used exclusively for dealing with ballast.

The ballast system serving the spaces located outside the cargo area may be used for this purpose.

5.3.3 Emergency discharge of segregated ballast (1/6/2021)

Provisions may be made for emergency discharge of the segregated ballast by means of a connection to a cargo pump through a detachable spool piece provided that:

- non-return valves are fitted on the segregated ballast connections to prevent the passage of chemical products to the ballast tank, and
- shut-off valves are fitted to shut off the cargo and ballast lines before the spool piece is removed.

The detachable spool piece is to be placed in a conspicuous position in the pump room and a permanent warning notice restricting its use is to be displayed in a conspicuous position adjacent to it.

5.3.4 Carriage of ballast water in cargo tanks (1/6/2021)

- a) Provisions are to be made for filling cargo tanks with sea water, where permitted. Such ballast water is to be processed and discharged as per [4.2.1] and [6.3.8].
- b) The sea water inlets and overboard discharges serving cargo tanks for the purpose of a) are not to have any

connection with the ballast system of segregated ballast tanks.

- c) Cargo pumps may be used for pumping ballast water to or from the cargo tanks, provided two shut-off valves are fitted to isolate the cargo piping system from the sea inlets and overboard discharges.
- d) Ballast pumps serving segregated ballast tanks may be used for filling the cargo tanks with sea water provided that the connection is made on the top of the tanks and consists of a detachable spool piece and a screw-down non-return valve to avoid siphon effects.

5.3.5 Ballast pipes passing through tanks (1/6/2021)

- a) In the ship of 600 tonnes deadweight and above, ballast piping is not to pass through cargo tanks except in the case of short lengths of piping complying with [5.1.3] b).
- b) Sliding type couplings are not to be used for expansion purposes where ballast lines pass through cargo tanks. Expansion bends only are permitted.

5.3.6 Integrated cargo and ballast system (1/6/2021)

The requirements for integrated cargo and ballast systems are given in Ch 7, Sec 4, [3.5].

5.4 Scupper pipes

5.4.1 (1/6/2021)

Scupper pipes are not to pass through cargo tanks except, where this is impracticable, in the case of short lengths of piping complying with the following provisions:

- they are of steel
- they have only welded or heavy flanged joints the number of which is kept to a minimum
- they are of substantial wall thickness as per Pt C, Ch 1, Sec 10, Tab 22, column 1.

5.5 Cargo temperature control

5.5.1 Cargo heating and cooling systems (1/6/2021)

- a) Cargo temperature control systems

IBC CODE REFERENCE : Ch 7, 7.1.1

Wherever a particular temperature (higher or lower than the ambient temperature) is required to be maintained for the preservation of the cargo, one of the following systems is to be adopted:

- 1) thermally insulated tanks capable of maintaining the temperature of the cargo within acceptable limits for the time of the voyage.
 - 2) a heating or cooling plant or refrigerating plant.
 - 3) a combination of 1) and 2) above.
- b) Additional requirements for heating and cooling plants
- IBC CODE REFERENCE : Ch 7, 7.1.1
- 1) Manifolds for the delivery and backflow of heating media are to be fitted on the weather deck; connec-

tions to cargo tanks for inlet and outlet are to be in way of the cargo tank top.

- 2) Where the heat exchanger room is located in the accommodation area and considered as gas-safe, it is to be treated as a machinery space (not a category A machinery space) and provided with independent mechanical extraction ventilation as well as with scuppers discharging directly into the machinery space.
 - 3) The maximum temperature of steam and heating media within the cargo area is to be adjusted to take into account the temperature class of the cargoes.
- c) Reference temperature

IBC CODE REFERENCE : Ch 7, 7.1.1

Wherever the cargo temperature is maintained by a heating or refrigerating plant, unless otherwise indicated in the contract specification, the system is to be designed taking into account the reference temperatures indicated in Tab 2.

Table 2 (1/6/2021)

Reference temperature (°C)		
	Heating system	Cooling system
Sea	0	32
Air	5	45

- d) Redundancy
- IBC CODE REFERENCE : Ch 7, 7.1.1
- Wherever the heating or cooling system is essential for the preservation of the cargo, the following components are to be duplicated:
- 1) heating or cooling sources; in cargo heating systems, the Society may permit only one fired boiler capable of supplying the requested heating capacity to be installed, provided that sufficient spares for the burner and relevant auxiliaries are carried on board to enable any failure of the burner to be rectified by the ship's crew
 - 2) circulating pumps for cargo and heating or cooling media; if suitable for the use, cargo pumps may be employed for the circulation of the heating or cooling media
 - 3) refrigeration plant.

5.5.2 Valves and other fittings (1/6/2021)

- a) Means for purging
- IBC CODE REFERENCE : Ch 7, 7.1.3
- Cargo heating or cooling systems are to be fitted with the necessary connections to purge, by inert gas or compressed air, the heating or cooling circuit of each cargo tank and to perform the pressure testing of the system.

5.5.3 Cargo temperature measuring system (1/6/2021)

- a) Alarm
- IBC CODE REFERENCE : Ch 7, 7.1.5
- 1) An alarm system is required for those products which are carried in a heated condition (see para-

graph 15.13.6 of the IBC Code) and for which, in column "o" of the tables in Chapter 17 of the IBC Code, reference is made to the requirements of paragraph 15.13 of the IBC Code.

- 2) An alarm system is required for those products for which a carrying temperature not greater than certain limits is required by Chapter 15 of the IBC Code, such as elementary phosphorus and molten sulphur.
- 3) An alarm connection to the navigating bridge and to the cargo control station, if fitted, is to be provided.

5.5.4 Requirements for special products (1/6/2021)

- a) Products which may damage the cargo heating or cooling system
- IBC CODE REFERENCE : Ch 7, 7.1.6
- 1) The provisions of paragraph 7.1.6 of the IBC Code also apply to products which may damage the cargo heating or cooling system.
 - 2) If the sampling equipment mentioned in paragraph 7.1.6.3 of the IBC Code consists of an observation tank for drains, this tank is generally to comply with the following requirements:
 - it is to be located in the cargo area and provided with an air pipe with the end fitted with a flame screen, as per the Rules, and arranged at not less than 3 m from openings of accommodation spaces and from sources of ignition
 - it is to be fitted with a connection for discharge into the slop tanks with associated shut-off valves and sight glass and equipped with a sampling cock for backflowing medium analysis.

6 Cargo pumping and piping systems

6.1 General

6.1.1 (1/6/2021)

A complete system of pumps and piping is to be fitted for handling the cargo.

6.1.2 (1/6/2021)

Except where expressly permitted, and namely for the bow and stern cargo loading and unloading stations, this system is not to extend outside the cargo area and is to be independent of any other piping system on board.

6.2 Cargo pumping system

6.2.1 Number and location of cargo pumps (1/6/2021)

- a) Each cargo tank is to be served by at least two separate fixed means of discharging and stripping. However, for tanks fitted with an individual submerged pump, the second means may be portable.
- b) Cargo pumps are to be located:
 - in a dedicated pump room, or
 - on deck, or
 - when designed for this purpose, within the cargo tanks.

6.2.2 Use of cargo pumps (1/6/2021)

- a) Except where expressly permitted in [5.2] and [5.3], cargo pumps are to be used exclusively for handling the liquid cargo and are not to have any connections to compartments other than cargo tanks.
- b) Subject to their performance, cargo pumps may be used for tank stripping.
- c) Cargo pumps may be used, where necessary, for the washing of cargo tanks.

6.2.3 Cargo pumps drive (1/6/2021)

- a) Prime movers of cargo pumps are not to be located in the cargo area, except in the following cases:
 - steam driven machine supplied with steam having a temperature not exceeding 220 °C
 - hydraulic motors
 - electric motors of certified type.
- b) Pumps with a submerged electric motor are not permitted in cargo tanks.
- c) Where cargo pumps are driven by a machine which is located outside the cargo pump room, the following arrangements are to be made:
 - 1) drive shafts are to be fitted with flexible couplings or other means suitable to compensate for any misalignment;
 - 2) the shaft bulkhead or deck penetration is to be fitted with a gas-tight gland of a type approved by the

Society. The gland is to be efficiently lubricated from outside the pump room and so designed as to prevent overheating. The seal parts of the gland are to be of material that cannot initiate sparks;

- 3) temperature sensing devices are to be fitted for bulkhead shaft gland bearings; see [6.2.5].

Note 1: The provisions of this requirement also apply to stripping pumps and ballast pumps.

6.2.4 Design of cargo pumps (1/6/2021)

- a) Materials of cargo pumps are to be suitable for the products carried.
- b) The delivery side of cargo pumps is to be fitted with relief valves discharging back to the suction side of the pumps (bypass) in closed circuit. Such relief valves may be omitted in the case of centrifugal pumps with a maximum delivery pressure not exceeding the design pressure of the piping, with the delivery valve closed.
- c) Pump casings are to be fitted with temperature sensing devices; see [6.2.5].

6.2.5 Monitoring of cargo pumps (1/6/2021)

Cargo pumps are to be monitored as required in Tab 3.

6.2.6 Control of cargo pumps (1/6/2021)

Cargo pumps are to be capable of being stopped from:

- a position outside the pump room, and
- a position next to the pumps.

Table 3 : Monitoring of cargo pumps (1/6/2021)

Equipment, parameter	Alarm (1)	Indication (2)	Comments
pump, discharge pressure		L	<ul style="list-style-type: none"> • on the pump (3), or • next to the unloading control station
pump casing, temperature	H		visual and audible, in cargo control room or pump control station
bulkhead shaft gland bearing, temperature	H		visual and audible, in cargo control room or pump control station
(1) H = high (2) L = low (3) and next to the driving machine if located in a separate compartment			

6.3 Cargo transfer**6.3.1 Piping scantlings (1/6/2021)**

- a) Pipe wall thickness calculation

- 1) Piping subjected to green seas

IBC CODE REFERENCE : Ch 5, 5.1.1

For piping subjected to green seas, the design pressure P , in bar, in the formula in paragraph 5.1.1 of the IBC Code is to be replaced by an equivalent pressure P' given by the following formula:

$$P' = \frac{1}{2} \left(P + \sqrt{P^2 + 0,006 R' K \frac{D_c}{D}} \right)$$

where:

D_c : External diameter of the pipe taking into account the insulation (in mm), whose thickness is to be taken at least equal to:
 40 mm if $D \leq 50$ mm
 80 mm if $D \geq 150$ mm

Intermediate values are to be determined by interpolation.

R' : Drag corresponding to the effect of green seas, in da N/m², such as given in Tab 4 as a function of the location of the pipes and of their height H (in m) above the deepest loadline; intermediate values are to be determined by interpolation.

K : permissible stress, in N/mm²

b) Corrosion allowance

IBC CODE REFERENCE : Ch 5, 5.1.1

The coefficient c (added corrosion thickness) for the formula in paragraph 5.1.1 of the IBC Code is normally to be equal to at least 3 mm. The Society may accept a lesser value for pipes made of austenitic or austenitic-ferritic stainless steel, pipes with internal lining or, if applicable, pipes with acceptable external protective lining or painting.

6.3.2 Piping fabrication and joining details (1/6/2021)

a) Pipes not required to be joined by welding

1)

IBC CODE REFERENCE : Ch 5, 5.2.2

Cargo piping is to be welded except for necessary flanged connections to valves, expansion joints (as permitted in paragraph 5.2.2.1 of the IBC Code), spool pieces and similar fittings or where required for coating, lining, fabrication, inspection or maintenance.

2) Flanged connections

IBC CODE REFERENCE: Ch 5, 5.3.1

Flange types A and B in Pt C, Ch 1, Sec 10, Fig 1 are acceptable in piping systems with design pressure $p > 1,6$ MPa.

Flange types A, B, C1, C2 and C3 are acceptable in piping systems with design pressure $p \leq 1,6$ MPa.

The type of flanges on open-ended cargo piping or cargo piping placed inside cargo tanks may be considered by the Society on a case-by-case basis.

b) Expansion joints

IBC CODE REFERENCE : Ch 5, 5.2.4

The use of bellows is not permitted for corrosive and polymerising products, except if provision is made to prevent stagnation of liquids.

c) Non-destructive testing of welding

1) IBC CODE REFERENCE : Ch 5, 5.2.5

- Butt welded pipes and accessories are to be radiographic at random and entirely checked by means of a dye-penetrant test or an equivalent method.
- radiographic examinations are to cover at least 10% of the connections and may be extended, at the request of the Surveyor depending on the results of the inspection.
- Relaxation of the above requirements may be considered by the Society on a case-by-case basis for pipes welded at workshops. However, this only applies to ships exclusively intended to carry cargoes with minor fire risk.

d) Certification, inspection and testing of piping system

Pipes, valves, fittings and other components are to be tested according to Tab 5.

Table 4 (1/6/2021)

External diameter of pipe (1)	Aft of the quarter of the ship's length			Forward of the quarter of the ship's length		
	H≤8	H=13	H≥18	H≤8	H=13	H≥18
≤25	1500	250	150	2200	350	150
50	1400	250	150	2000	350	150
75	1100	250	150	1600	350	150
100	700	250	150	700	350	150
≥150	500	250	150	700	350	150

(1) D_c if the pipe is insulated, D otherwise.

Table 5 (1/6/2021)

No.	Item	Tests for materials (1)		Inspections and tests for the products (1)		
		Tests required	Type of material certificate (2) (3)	During manufacturing (NDT)	After completion	Type of product certificate (2)
1	pipes, flanges and fittings	X	C (4)		X	C
2	valves	X	C (4)	X (5)	X	C

(1) X = test required.

(2) C = class certificate, W = works' certificate.

(3) W is requested for pipes of open-ended piping and piping within cargo tanks.

(4) W is accepted for $d < 100$ mm

(5) if of welded construction

No.	Item	Tests for materials (1)		Inspections and tests for the products (1)		
		Tests required	Type of material certificate (2) (3)	During manufacturing (NDT)	After completion	Type of product certificate (2)
3	pumps	X	W		X	C
4	cargo tank P/V and high velocity valves	X	C	X	X	C
<p>(1) X = test required. (2) C = class certificate, W = works' certificate. (3) W is requested for pipes of open-ended piping and piping within cargo tanks. (4) W is accepted for d < 100 mm (5) if of welded construction</p>						

6.3.3 Materials (1/6/2021)

- a) Cargo piping is, in general, to be made of steel or cast iron.
- b) Valves, couplings and other end fittings of cargo pipe lines for connection to hoses are to be of steel or other suitable ductile material.
- c) Spheroidal graphite cast iron may be used for cargo oil piping.
- d) Grey cast iron may be accepted for cargo oil lines:
 - within cargo tanks, and
 - on the weather deck for pressure up to 1,6 Mpa.
It is not to be used for manifolds and their valves of fittings connected to cargo handling hoses.
- e) Plastic pipes may be used in the conditions specified in Pt C, Ch 1, App 3. Arrangements are to be made to avoid the generation of static electricity.

6.3.4 Piping arrangements (1/6/2021)

- a) Arrangement of cargo piping
 - 1) Arrangement of cargo piping under deck
IBC CODE REFERENCE : Ch 5, 5.5.2
The intent of the provisions in paragraph 5.5.2 of the IBC Code is to preclude the hazard of cargo leaking past a shut-off valve gland into the space where the valve is located.
 - 2) Arrangement of cargo piping on deck
IBC CODE REFERENCE : Ch 5, 5.5.2
Cargo piping on cargo tanks is to be extended down to the bottom of each tank.
 - 3) Aluminised pipes
IBC CODE REFERENCE : Ch 5, 5.5
Aluminised pipes may be permitted in ballast tanks, in inerted cargo tanks and, provided the pipes are protected from accidental impact, in hazardous areas on open deck.
 - 4) Cargo pipes passing through tanks or compartments
 - Cargo piping and similar piping to cargo tanks is not to pass through ballast tanks except in the case of short lengths of piping complying with [5.1.3], item b).
 - Cargo piping may pass through vertical fuel oil tanks adjacent to cargo tanks on condition that

the provisions of [5.1.3], item b) are complied with.

- 5) Cargo piping passing through bulkheads
Cargo piping passing through bulkheads is to be so arranged as to preclude excessive stresses at the bulkhead. Bolted flanges are not to be used in the bulkhead.
- 6) Valves
 - Stop valves are to be provided to isolate each tank.
 - A stop valve is to be fitted at each end of the cargo manifold.
 - When a cargo pump in the cargo pump room serves more than one cargo tank, a stop valve is to be fitted in the cargo pump room on the line leading to each tank.
 - Main cargo valves located in the cargo pump room below the floor gratings are to be remote controlled from a position above the floor.

- b) Removable piping systems
IBC CODE REFERENCE : Ch 5, 5.5
Pumps, piping and associated fittings are to constitute a permanently fitted system; in general, removable parts are not allowed, except for specific cases for which it can be proved, to the satisfaction of the Society, that no effective alternative solutions are available. In such circumstances, the safety measures deemed necessary will be considered by the Society on a case-by-case basis.

6.3.5 Cargo transfer control systems (1/6/2021)

- a) General
IBC CODE REFERENCE : Ch 5, 5.6.1
 - One blank flange is to be provided in addition to the stop valve required in paragraph 5.6.1.2 of the IBC Code at each cargo hose connection.
 - The requirements of paragraph 5.6.1 of the IBC Code are not intended to be additional to those for piping below deck in 5.5.2 and 5.5.3 of the IBC Code.
- b) Control, monitoring and alarm devices and cargo control room
IBC CODE REFERENCE : Ch 5, 5.6
 - a) The cargo pump control is to be fitted in a position which is readily accessible, even in the event that

the cargo piping or hoses break. This position is to be clearly indicated.

- b) Where a cargo control room is fitted, the following controls, monitoring and alarms are to be connected to this room:
- cargo pump control
 - control of loading/unloading valves
 - level gauges
 - temperature indicators
 - high level alarms
 - very high level alarms
 - high/low temperature alarms
 - high/low pressure alarms
 - fixed gas detecting system alarms.
- c) In general, high/low temperature alarms are also to be transduced to the navigating bridge.
- d) The cargo control room is to be located above the weather deck and may be considered as a dangerous space or a safe space, depending on its location and on the possible presence of a product or of its vapours. If it is considered a dangerous space, it is to be provided with a ventilation system capable of supplying at least 20 air changes per hour, it is not to be located in the accommodation area and only safe type electrical equipment is allowed.
- e) A cargo control room without cargo pump and valve control is defined as a "cargo control station".

6.3.6 Ship's cargo hoses (1/6/2021)

- a) Compatibility
- 1) Cargo hoses are to be of a type approved by the Society for the intended conditions of use.
 - 2) Hoses subject to tank pressure or pump discharge pressure are to be designed for a bursting pressure not less than 4 times the maximum pressure under cargo transfer conditions.
 - 3) The ohmic electrical resistance of cargo hoses is not to exceed $10^6 \Omega$.

IBC CODE REFERENCE : Ch 5, 5.7.1

The requirement of paragraph 5.7.1 of the IBC Code applies to cargo hoses carried on board the vessel and "compatibility with the cargo" means that:

- a) the cargo hose does not lose its mechanical strength or deteriorate unduly when in contact with the cargo, and
- b) the cargo hose material does not affect the cargo in a hazardous way.

Consideration is to be given to internal and external surfaces with respect to the above where hoses may be used as an integral part of, or connected to, emergency cargo pumps and submerged in the cargo tank.

6.3.7 Bonding (1/6/2021)

- a) Static electricity
- 1) Acceptable resistance

IBC CODE REFERENCE : Ch 10, 10.3

To avoid the hazard of an incentive discharge due to the build-up of static electricity resulting from the flow of the liquid/gases/vapours, the resistance between any point on the surface of the cargo and slop tanks, piping systems and equipment, and the hull of the ship is not to be greater than $10^6 \Omega$.

- 2) Bonding straps

IBC CODE REFERENCE : Ch 10, 10.3

Bonding straps are required for cargo and slop tanks, piping systems and equipment which are not permanently connected to the hull of the ship, for example:

- a) independent cargo tanks
- b) cargo tank piping systems which are electrically separated from the hull of the ship
- c) pipe connections arranged for the removal of the spool pieces.
- d) wafer-style valves with non-conductive (e.g. PTFE) gaskets or seals.

Where bonding straps are required, they are to be:

- clearly visible so that any shortcoming can be clearly detected
- designed and sited so that they are protected against mechanical damage and are not affected by high resistivity contamination, e.g. corrosive products or paint
- easy to install and replace.

6.3.8 Discharge of contaminated water (1/6/2021)

- a) Location of discharge outlet
- For discharge of cargo contaminated water, an outlet located below the waterline in vicinity of the turn of the bilge, shall be arranged within the cargo area.
 - The outlet(s) shall be located such that the cargo contaminated discharges will not enter the ship's seawater intakes.

- b) Sizing of the discharge outlet

The internal diameter of the outlet shall not be less than:

$$D = QD / 5L$$

where: QD = discharge rate [m^3/h]

L = distance of outlet from forward perpendicular [m].

In the case of angled outlets, only the velocity component of the discharge perpendicular to the ship's shell plating shall be considered when determining QD.

The discharge rate assumed as the basis for outlet(s) sizing shall not be less than the aggregate throughput of the washing machines in anyone tank.

7 Cargo tanks and fittings

7.1 Application

7.1.1 (1/6/2021)

The provisions of this paragraph apply to cargo tanks and slop tanks.

7.2 Cargo tank venting

7.2.1 Large amounts of drainage (1/6/2021)

IBC CODE REFERENCE: Ch 8, 8.2.2

When large amounts of drainage from vent lines of the cargo tanks are envisaged, a hose connection to the drain line of the slop tank is to be provided.

7.2.2 Position of vent outlets from tanks intended for flammable and toxic products (1/6/2021)

IBC CODE REFERENCE: Ch 8, 8.3.3

Vent outlets of cargo tanks intended for the carriage of flammable or toxic products are to be arranged at a distance of not less than 3 m from exhaust ducts and as far as possible from inlet ducts to pump rooms and cargo pump rooms.

7.3 Cargo tank gas freeing

7.3.1 Fans (1/6/2021)

IBC CODE REFERENCE : Ch 8, 8.5

- The impellers and housing of either fixed or portable fans fitted in dangerous spaces are to be of non-sparking materials according to paragraph 12.1.8 of the IBC Code.
- In the case of fans installed in safe spaces, two non-return devices are to be fitted to avoid return of flammable and/or toxic cargo vapours to safe spaces when the ventilation system is shut down. These non-return devices are to operate in all normal conditions of ship trim and list.

7.4 Environmental control

7.4.1 Control by inerting or padding (1/6/2021)

IBC CODE REFERENCE : Ch 9, 9.1.3

The padding medium is to be compatible from the point of view of safety with the products to be carried, it is not to react with them and with air and it is to have chemical and physical properties deemed suitable by the Society. The system is to comply with the requirements for inert gas systems, as applicable.

7.4.2 Control by drying (1/6/2021)

IBC CODE REFERENCE : Ch 9, 9.1.4

In the case of simultaneous carriage of mutually incompatible products, dry gas supply piping systems to each cargo space are to be separate from each other.

7.4.3 Special requirements for inert gas systems on barge-chemical (1/6/2021)

- Applicability
IBC CODE REFERENCE : Ch 9, 9.1
Pt C, Ch 4, Sec 1, [8.2] applies.
- Simultaneous carriage of incompatible products
IBC CODE REFERENCE : Ch 9, 9.1
The inert gas system is to comply with the requirements of paragraph 9.1.5.1 of the IBC Code, adapted, to the satisfaction of the Society, to the individual characteristics of the products to be carried. In the case of simultaneous carriage of mutually incompatible products, inert

gas supply piping systems to each cargo space are to be separate from each other.

- Ships with no fixed inert gas system
IBC CODE REFERENCE : Ch 9, 9.1
Where no fixed installation for inert gas and/or dry gas production is provided for on board, the minimum quantity to be kept on board is established by the Master, based on the duration of the voyage, the anticipated daily temperature variations, gas leakage through cargo tank seals and experience of previous similar cases.
- Additional requirements
IBC CODE REFERENCE : Ch 9, 9.1
 - These requirements apply where an inert gas system based on oil fired inert gas generators is fitted on board chemical tankers. Any proposal to use other sources of inert gas will be specially considered.
 - In addition to the provisions in paragraph 9.1.5.1 of the IBC Code, the inert gas system is to comply with the requirements of IMO Resolution A.567(14). Any use of the word "Administration" in the Resolution is to be considered as meaning the Society.
 - As an alternative to the water seal in the inert gas line on deck, an arrangement consisting of two shut-off valves in series with a venting valve in between may be accepted. The following conditions apply:
 - The operation of the valve is to be automatically executed. Signals for opening/closing are to be taken from the process directly, e.g. inert gas flow or differential pressure.
 - An alarm for faulty operation of the valves is to be provided, e.g. the operation status of "blower stop" and "supply valve(s) open" is an alarm condition.
 - In addition to the requirements detailed in Resolution A.567(14), the followings are to be complied with:
 - Plans in diagrammatic form are to be submitted for appraisal and are to include the following:
 - details and arrangement of inert gas generating plant including all control monitoring devices
 - arrangement of piping system for distribution of the inert gas.
 - In all cases, automatic combustion control, capable of producing suitable inert gas under all service conditions, is to be fitted.
 - When two blowers are provided, the total required capacity of the inert gas system is preferably to be divided equally between the two and in no case is one blower to have a capacity less than 1/3 of the total required.
 - Materials used in inert gas systems are to be suitable for their intended purpose in accordance with the Rules. In particular those parts of scrubbers, blowers, non-return devices, scrubber effluent and other drain pipes which may be subjected to corrosive action of the gases and/or liquids are to be either constructed of corrosion-

resistant material or lined with rubber, glass fibre, epoxy resin or other equivalent coating material.

- A compartment in which any oil fired inert gas generator is situated is to be treated as a machinery space of category A in respect of fire protection.
- All of the equipment is to be installed on board and tried under working conditions to the satisfaction of the Surveyor.

7.4.4 Ventilation (1/6/2021)

IBC CODE REFERENCE : Ch 9, 9.1

When a cargo space ventilation system other than the venting system mentioned under paragraph 8.2 of the IBC Code is required by these provisions, such system is to comply with the requirements established by the Society in each case.

7.4.5 Mechanical ventilation in the cargo (1/6/2021)

a) Spaces normally entered during cargo handling operations

1) Miscellaneous requirements

- Ventilation system stopping
IBC CODE REFERENCE : Ch 12, 12.1
All required ventilation systems are to be capable of being stopped from a position located outside the served spaces and above the weather deck.
- Warning notices
IBC CODE REFERENCE : Ch 12, 12.1
In the proximity of entrances to all spaces served by the required mechanical ventilation systems, a clearly visible warning is to be posted requiring such spaces to be adequately ventilated prior to entering and relevant ventilation systems to be kept in operation all the time persons are present in the spaces themselves.
- Prevention of dangerous operation of electric Motors
IBC CODE REFERENCE : Ch 12, 12.1
A suitable automatic device is to be fitted to prevent operation of electric motors driving cargo pumps and operation of other electrical equipment not of a certified safe type prior to ventilating the spaces where such motors or equipment are located, in order to render them gas-safe (to this end it is pointed out that IEC provisions require at least 10 changes of air based on the volume of the served space).
- Prevention of dangerous operation of cargo pumps
IBC CODE REFERENCE : Ch 12, 12.1
An automatic device is to be fitted capable of stopping motors driving cargo pumps and de-energising any other electrical equipment not of a certified safe type in the case of stoppage of ventilation in spaces where such motors and equipment are fitted. This provisions does not

apply to motors and other electrical equipment fitted in the engine room.

- Alternative to extraction type ventilation systems
IBC CODE REFERENCE : Ch 12, 12.1
As an alternative to ventilation systems of the extraction type, required in a)1) bullet 4), a ventilation system of the positive pressure type may be accepted:
 - in the case of cargo pump rooms adjacent to cargo tanks or to other gas-dangerous spaces, or
 - where, in adjacent gas-safe spaces, inclusive of spaces containing motors of cargo pumps, an adequate over-pressure is kept in relation to the cargo pump rooms themselves.
- Location of upper end of inlet ducts
IBC CODE REFERENCE : Ch 12, 12.1
With reference to the requirements of a)1) bullet 5), the upper ends of inlet ducts are generally to be located at a distance not less than 3 m from ventilation ducts and air intakes serving the safe spaces mentioned therein.
- Minimum distance between inlet and extraction ducts
IBC CODE REFERENCE : Ch 12, 12.1
With reference to 12.1.6 of IBC Code, the upper ends of (inlet and extraction) ventilation ducts serving the same space are to be located at a distance from each other, measured horizontally, of not less than 3 m and, in general, at an adequate height above the weather deck, but in any case not less than 2,4 m. Greater heights are required in paragraph 15.17 of the IBC Code.
- Upper ends of ventilation ducts in ships carrying materials producing flammable
IBC CODE REFERENCE : Ch 12, 12.1
For flammable products, or for products which may react with the ship's materials producing flammable vapours (such as strong acids), the upper ends of ventilation ducts are to be located at a distance of not less than 3 m from any source of ignition, as per the provisions of Ch 8, Sec 8, [2.1].
- Dampers
IBC CODE REFERENCE : Ch 12, 12.1
Ventilation ducts are to be provided with metallic dampers, fitted with the indication "open" and "closed". The dampers are to be located above the weather deck, in a readily accessible position.
- Location of electric motors of fans
IBC CODE REFERENCE : Ch 12, 12.1
Electric motors driving fans are to be placed outside the served spaces and outside the ventilation ducts, in a suitable position with respect to the presence of flammable vapours.
- Penetration of motor shafts through bulkheads

IBC CODE REFERENCE : Ch 12, 12.1

Runs of shafts of electric motors driving fans through bulkheads or decks of gas-dangerous spaces or through ventilation ducts are to be provided with gas-tight seals, with oil glands or equivalent means, deemed suitable by the Society.

2) Additional requirements for non-sparking fans

• Non-sparking fans

IBC CODE REFERENCE : Ch 12, 12.1

- A fan is considered as non-sparking if in both normal and abnormal conditions it is unlikely to produce sparks.
- The air gap between the impeller and the casing is to be not less than 0,1 of the shaft diameter in way of the impeller bearing and not less than 2 mm. It need not be more than 13 mm.

• Materials for non-sparking fans

IBC CODE REFERENCE : Ch 12, 12.1

- The impeller and the housing in way of the impeller are to be made of alloys which are recognised as being spark proof by appropriate tests.
- Electrostatic charges in both the rotating body and the casing are to be prevented by the use of antistatic materials. Furthermore, the installation on board of the ventilation units is to be such as to ensure their safe bonding to the hull.
- Tests may not be required for fans having the following combinations:
 - impellers and/or housings of non-metallic material, due regard being paid to the elimination of static electricity
 - impellers and housings of non-ferrous materials
 - impellers of aluminium alloys or magnesium alloys and a ferrous (including austenitic stainless steel) housing on which a ring of suitable thickness of non-ferrous materials is fitted in way of the impeller
 - any combination of ferrous (including austenitic stainless steel) impellers and housings with not less than 13 mm design tip clearance.
- The following impellers and housings are considered as sparking and are not permitted:
 - impellers of an aluminium alloy or magnesium alloy and a ferrous housing, regardless of tip clearance
 - housing made of an aluminium alloy or a magnesium alloy and a ferrous impeller, regardless of tip clearance
 - any combination of ferrous impeller and housing with less than 13 mm design tip clearance.

- Type test for non-sparking fans

IBC CODE REFERENCE : Ch 12, 12.1

Type tests on the finished product are to be carried out in accordance with the requirements of the Society or an equivalent national or international standard.

b) Pump rooms and other enclosed spaces normally entered

1) Clarification of general requirement

IBC CODE REFERENCE : Ch 12, 12.2

- The arrangements for the ventilation system of spaces to which paragraph 12.2 of the IBC Code applies are to comply, in general, with the provisions set out in the previous item a), as applicable.
- The provisions of paragraph 12.2 of the IBC Code apply to all pump rooms, whether or not the control for pumps and valves which are installed in such rooms is fitted externally.
- The distance of the upper ends of extraction and inlet ducts from air intakes and other openings of spaces mentioned in paragraph 12.1.5 of the IBC Code is not to be less than 3 m measured horizontally. These systems are to be capable of being controlled from outside the spaces they serve and, in the proximity of the entrances to such spaces, the warning notice mentioned in a)1)bullet 2) is to be posted.

c) Spaces not normally entered

1) Portable fans

IBC CODE REFERENCE : Ch 12, 12.3

- The type of portable fans and their connections to spaces to be ventilated are to be deemed suitable by the Society. Portable fans driven by electric or internal combustion motors are not acceptable.
- The arrangements for the ventilation of these spaces are to comply, in general, with the provisions set out in the previous item a), as applicable.

7.5 Instrumentation

7.5.1 Gauging (1/6/2021)

a) Types of gauging devices

1) Arrangement

IBC CODE REFERENCE : Ch 13, 13.1.1

- In almost all cases a cargo code which requires a high level alarm and overflow control also requires a closed gauging device. A cargo tank containing such a product therefore requires three sensors:
 - l) one level gauging

II) one high level alarm

III) one overflow control

- The sensing elements for I), II) and III) are to be separated, although sensors for II) and III) (reed switches, float chambers, electronic devices, etc.) may be contained in the same tube.
- Electronic, pneumatic and hydraulic circuits required for sensors I), II) and III) are to be independent of each other such that a fault on any one will not render either of the others inoperative.
- Where processing units are used to give digital or visual indication, such as in a bridge space, the independence of circuitry is to be maintained at least beyond this point.
- The power is to be supplied from distribution boards.
- Where a control room or a bridge space containing a modular unit is envisaged, separate level indication and visual alarms are to be provided for each of the functions I), II) and III). An audible alarm is also to be provided but since this is not directional it need not be separate.
- An audible alarm is also to be arranged in the cargo area
- Where there is no control room, an audible and visual alarm is to be arranged at the cargo control station.
- Testing of sensors is to be arranged from outside the tanks, although entry into product clean tanks is not precluded.
- Simulation testing of electronic circuits or circuits which are self-monitored is acceptable.

2) Example of restricted gauging device

IBC CODE REFERENCE : Ch 13, 13.1.1

A restricted gauging device may consist of a sounding pipe with an inside diameter not greater than 200 mm, fitted with a gas-tight plug. The pipe is to have holes in order to make its internal pressure equal to that of the tank. Therefore the holes are to be located inside the cargo tank in the proximity of the top.

7.5.2 Vapour detection (1/6/2021)

a) Vapour detection instruments

1) Spaces to be monitored

IBC CODE REFERENCE : Ch 13, 13.2.1

Vapour detection instruments, either fixed or portable, are to be of a type recognised suitable by the Society for the products to be carried. The spaces to be monitored are:

- cargo pump rooms
- spaces containing motors driving cargo pumps, except for the machinery space
- enclosed spaces containing cargo piping, equipment connected with cargo handling, coffer-

dams, enclosed spaces and double bottoms adjacent to cargo tanks

- pipe tunnels
- other spaces, in the opinion of the Society, depending
- on the ship type.

Where a fixed system is installed, it is to serve the spaces among those listed above which are normally entered by the crew.

b) Gas Measurements

The fitting of gas measuring equipment is subject to the provisions of Pt C, Ch 4, Sec 1, [5.2.4] b)1).

7.6 Tank washing systems

7.6.1 General (1/6/2021)

Adequate means are to be provided for cleaning the cargo tanks.

7.6.2 Washing machines (1/6/2021)

- a) Tank washing machines are to be of a type approved by the Society.
- b) Washing machines are to be made of steel or other electricity conducting materials with a limited propensity to produce sparks on contact.

7.6.3 Washing pipes (1/6/2021)

Washing pipes are to be built, fitted, inspected and tested in accordance with the applicable requirements of Pt C, Ch 1, Sec 10, depending on the kind of washing fluid.

7.6.4 Installation of washing systems (1/6/2021)

- a) Tank cleaning openings are not to be arranged in enclosed spaces.
- b) The complete installation is to be permanently earthed to the hull.

8 Certification, inspection and testing of piping systems

8.1 Application

8.1.1 (1/6/2021)

The provisions of this Article are related to cargo piping and other equipment fitted in the cargo area. They supplement those given in Pt C, Ch 1, Sec 10, [21] for piping systems other than cargo piping and [6.3.2] d) for cargo piping.

8.2 Workshop tests

8.2.1 Tests for materials (1/6/2021)

Where required in Tab 5, materials used for pipes, valves and fittings are to be subjected to the tests specified in Pt C, Ch 1, Sec 10, [21.3.2].

8.2.2 Hydrostatic testing (1/6/2021)

- a) Where required in Tab 5, cargo pipes, valves, fittings and pump casings are to be submitted to hydrostatic

tests in accordance with the relevant provisions of Pt C, Ch 1, Sec 10, [21.4].

- b) Expansion joints and cargo hoses are to be submitted to hydrostatic tests in accordance with the relevant provisions of Pt C, Ch 1, Sec 10, [21.4].
- c) Where fitted, bellow pieces of gas-tight penetration glands are to be pressure tested.

8.2.3 Tightness tests (1/6/2021)

Tightness of the following devices is to be checked:

- gas-tight penetration glands
- cargo tank P/V and high velocity valves.

Note 1: These tests may be carried out in the workshops or on board.

8.2.4 Check of the safety valves setting (1/6/2021)

The setting pressure of the pressure/vacuum valves is to be checked in particular with regard to Sec 4, [2.3.7].

8.3 Shipboard tests

8.3.1 Pressure test (1/6/2021)

After installation on board, the cargo piping system is to be checked for leakage under operational conditions.

9 Special Requirements

9.1 Ammonium nitrate solution (93% or less)

9.1.1 Ammonia injection procedure (1/6/2021)

IBC CODE REFERENCE: Ch 15, 15.2.6

Gaseous ammonia may be injected into the cargo while the latter is circulated by the cargo pump.

9.1.2 Cargo pumps seal (1/6/2021)

IBC CODE REFERENCE: Ch 15, 15.2.7

The seal for the centrifugal pump is to be a stuffing box provided with a lantern ring. Fresh water under pressure is to be injected into the stuffing box at the location of the lantern ring (see Fig 3).

9.2 Hydrogen peroxide solutions

9.2.1 Hydrogen peroxide solutions over 60% but not over 70% - Water spray system (1/6/2021)

IBC CODE REFERENCE: Ch 15, 15.5.10

It is specified that, for the purpose of evaluating the estimated size of the cargo spill in the case of failure, cargo piping/hose failure is to be assumed to be total.

9.3 Propylene oxide and mixtures of ethylene oxide/propylene oxide with an ethylene oxide content of not more than 30% by mass

9.3.1 Tank cleaning (1/6/2021)

IBC CODE REFERENCE: Ch 15, 15.8.3

Until an amendment in this respect is prepared at IMO, it is specified that the initial wording of the text of paragraph

15.8.3 of the IBC Code "Before loading," is to be intended as follows: "Before initial loading of these products and before each loading of these products subsequent to loading of other products....."

9.3.2 Joints in cargo lines (1/6/2021)

IBC CODE REFERENCE: Ch 15, 15.8.12

Screwed connections are only allowed for accessory and instrumental lines with an external diameter of 25 mm or less.

9.3.3 Oxygen content in tank vapour spaces (1/6/2021)

IBC CODE REFERENCE: Ch 15, 15.8.28

Analysing equipment to determine oxygen and propylene oxide contents is to be of a type recognised as suitable by the Society. When portable analysers are used, there are to be at least two. When a fixed system is installed, a portable analyser is also to be provided.

9.3.4 Valves at cargo hose connections (1/6/2021)

IBC CODE REFERENCE: Ch 15, 15.8.30

The closing time of shut-off valves provided at each cargo hose connection is to take account of the loading/unloading rate and is to be such as to avoid dangerous overpressure in cargo piping and hoses.

9.4 Sulphur (molten)

9.4.1 Fire-fighting system (1/6/2021)

- a) Cargo tank protection

IBC CODE REFERENCE: Ch 15, 15.10

Cargo tanks are to be protected by a fixed CO₂ extinguishing system in accordance with Part C, Chapter 4, or a steam extinguishing system. In the latter case, tank drying arrangements are to be provided to prevent corrosion after use of steam.

- b) CO₂ nozzles

IBC CODE REFERENCE: Ch 15, 15.10

Under normal service conditions, CO₂ tank feed nozzles are to be blanked off by means of a breaking disk to prevent pipes from being choked by sulphur. Nozzles are to be located at the upper part of the tank, above liquid level.

9.5 Acids

9.5.1 Lining (1/6/2021)

IBC CODE REFERENCE: Ch 15, 15.11.2

"Lining" is an acid-resistant material that is applied to the tank or piping system in a solid state with a defined elasticity property.

9.5.2 Electrical arrangements (1/6/2021)

IBC CODE REFERENCE: Ch 15, 15.11.15

In enclosed spaces adjacent to cargo tanks, electrical materials and equipment complying with the provisions of paragraph 10.1.2 of the IBC Code are allowed.

9.5.3 Leak detection system (1/6/2021)

IBC CODE REFERENCE: Ch 15, 15.11.7

There are to be at least two leak detection apparatuses designed and calibrated to detect leakage of cargo into spaces adjacent to cargo tanks. The apparatuses may consist of a pH-meter, a gas detector suitable for the detection of hydrogen/air mixtures, of a type deemed suitable by the Society, or of other suitable systems. These apparatuses may be fixed or portable; if a fixed system is installed, a portable apparatus is also to be provided.

9.6 Toxic products

9.6.1 Vapour return line to shore installation (1/6/2021)

IBC CODE REFERENCE: Ch 15, 15.12.2

The tank venting systems are to be fitted with a shut-off valve and a blank flange in way of the vapour return line to the shore installation.

9.7 Cargoes protected by additives

9.7.1 Prevention of blockage by polymerisation (1/6/2021)

IBC CODE REFERENCE: Ch 15, 15.13.6

In addition to being designed so as to avoid internal obstructions due to polymer formation, the venting systems are to be fitted with pressure/vacuum valves and devices to prevent the passage of flame which are accessible for inspection and maintenance.

9.8 Cargoes with a vapour pressure greater than 0,1013 MPa (1,013 bar) absolute at 37,8°C

9.8.1 System for maintaining cargo temperature below boiling point (1/6/2021)

IBC CODE REFERENCE: Ch 15, 15.14.1

Any system installed for the purpose of keeping the cargo temperature below its boiling point is to be constructed to the satisfaction of the Society.

9.8.2 Return of expelled gases (1/6/2021)

IBC CODE REFERENCE: Ch 15, 15.14.4

The tank venting systems are to be fitted with a shut-off valve and a blank flange in way of the vapour return line to the shore installation.

9.9 Special cargo pump room requirements

9.9.1 Clarification (1/6/2021)

IBC CODE REFERENCE: Ch 15, 15.18

As far as concerns the possibility of allowing the arrangement of cargo pump rooms below deck in specific cases, it is specified that, in practice, no circumstance can be foreseen where such an arrangement may be permitted.

9.10 Overflow control - Independence of systems

9.10.1 Gauging devices (1/6/2021)

IBC CODE REFERENCE: Ch 15, 15.19

In almost all cases where, for the carriage of a product, a cargo high level alarm or cargo overflow control is required, a closed gauging device is also required.

9.10.2 Separation of device sensing elements (1/6/2021)

IBC CODE REFERENCE: Ch 15, 15.19

A cargo tank intended to carry such a product therefore requires:

- level gauging
- high level alarm
- overflow control.

The sensing elements for the devices under a), b) and c) are to be separated, although sensors for b) and c) (micro-switches, float chambers, electronic devices, etc.) may be contained in the same metal tube sections.

9.10.3 Electronic and hydraulic circuits for sensors (1/6/2021)

IBC CODE REFERENCE: Ch 15, 15.19

Electronic, pneumatic and hydraulic circuits required for sensors for a), b) and c) are to be independent of each other such that a fault on any one of them will not render either of the others inoperative. Where processing units are used to give digital or visual indication such as in a bridge space, the independence of circuitry is to be maintained at least up to such units. The power is to be supplied from distribution boards.

9.10.4 Alarms in cargo control room (1/6/2021)

IBC CODE REFERENCE: Ch 15, 15.19

Where a cargo control room or a bridge space containing a modular unit is envisaged, separate level indications and visual alarms are to be provided for each of the functions a), b) and c). An audible alarm is also to be provided; there need not be a separate alarm for each function since separate alarms could not be distinguished. An audible alarm is also to be arranged in the cargo area.

9.10.5 Alarms where cargo control room is not provided (1/6/2021)

IBC CODE REFERENCE: Ch 15, 15.19

- Where no cargo control room is provided, an audible and visual alarm is to be arranged at the cargo control station, which generally coincides with the navigating bridge.
- The audible and visual high level and cargo overflow alarms are to be located so as to be easily heard and noticed by the personnel in charge of loading/unloading operations. Attention is drawn to the fact that such alarms are generally grouped together into two independent signals; therefore it is not possible to single out directly the cargo tank from which the alarm signal is coming. In such cases, the Master is to arrange for a person to be present at the cargo control station, in order to

be able to warn the personnel in charge of loading operations on deck.

9.10.6 Testing of sensors (1/6/2021)

IBC CODE REFERENCE: Ch 15, 15.19

Testing of sensors is to be arranged from outside the tanks, although entry into product clean tanks is not prohibited. Simulation testing of electronic circuits or circuits which are self-monitoring is acceptable.

Figure 3 : Seal (1/6/2021)

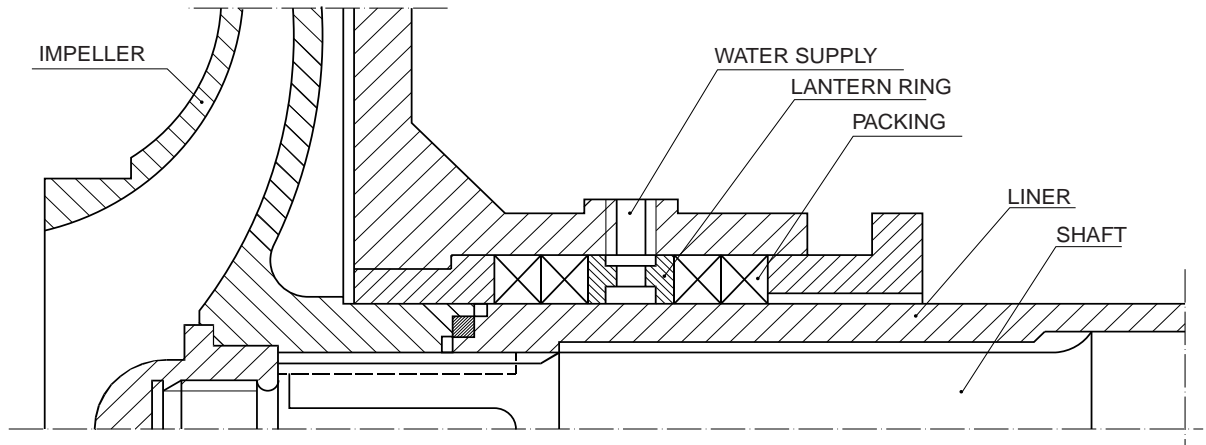

SECTION 8

ELECTRICAL INSTALLATIONS

1 Electrical installations for units with service notation "barge-oil"

1.1 Application

1.1.1 (1/6/2021)

The requirements in this item [1] apply, in addition to those contained in Part C, Chapter 2, to ships with the service notation **barge-oil**.

1.2 Exemptions

1.2.1 (1/5/2013)

The requirements in Pt C, Ch 2, Sec 3, [2.2.1] and [2.3.1] are not applicable in the case of vessels without persons on board.

1.3 Documentation to be submitted

1.3.1 (1/5/2013)

In addition to the documentation requested in Pt C, Ch 2, Sec 1, Tab 1, the following are to be submitted for approval:

- a) plan of hazardous areas
- b) document giving details of types of cables and safety characteristics of the equipment installed in hazardous areas
- c) diagrams of tank level indicator systems, high level alarm systems and overflow control systems where requested.

1.4 System of supply

1.4.1 (1/5/2013)

Earthed systems with hull return are not permitted, with the following exceptions to the satisfaction of the Society:

- a) impressed current cathodic protective systems
- b) limited and locally earthed systems, such as starting and ignition systems of internal combustion engines, provided that any possible resulting current does not flow directly through any hazardous area
- c) insulation level monitoring devices, provided that the circulation current of the device does not exceed 30 mA under the most unfavourable conditions
- d) intrinsically safe systems.

1.4.2 (1/5/2013)

In insulated distribution systems, no current carrying part is to be earthed, other than:

- a) through an insulation level monitoring device
- b) through components used for the suppression of interference in radio circuits.

1.4.3 (1/5/2013)

The additional limitations in the choice of the system of supply (type of distribution system) as per SOLAS Ch.II-1

Reg. 45.4.3 apply to ships subject to the SOLAS Convention.

1.5 Electrical equipment

1.5.1 (1/5/2013)

Electrical equipment, cables and wiring are not to be installed in hazardous locations unless they conform with standards not inferior to those given in IEC 60092-502 Standard.

However, for locations not covered by such standards, electrical equipment, cables and wiring which do not conform to the standards may be installed in hazardous locations based on a risk assessment to the satisfaction of the Society, to ensure that an equivalent level of safety is assured.

1.6 Earth detection

1.6.1 (1/5/2013)

For both insulated and earthed distribution systems a device, or devices, are to be installed to continuously monitor the insulation to earth and to give an audible and visual alarm at a manned position in the event of an abnormally low level of insulation resistance and/or high level of leakage current.

The above is not applicable to systems mentioned in [1.3.1].

1.7 Precautions against inlet of gases or vapours

1.7.1 (1/5/2013)

Suitable arrangements are to be provided, to the satisfaction of the Society, so as to prevent the possibility of gases or vapours passing from a gas-dangerous space to another space through runs of cables or their conduits.

1.8 Electrical equipment permitted in hazardous areas

1.8.1 (1/5/2013)

Electrical equipment permitted in hazardous areas is that indicated in Pt C, Ch 2, Sec 3, [10.1.4], Pt C, Ch 2, Sec 3, [10.1.5], and Pt C, Ch 2, Sec 3, [10.1.6].

1.8.2 (1/5/2013)

In addition to the requirements of [1.8.1], in Zone 1 and Zone 2 the installation of the following is permitted:

hull fittings containing the terminals or shell plating penetrations for anodes or electrodes of an impressed current cathodic protection system, or transducers such as those for depth sounding or log systems, provided that such fittings are of gas-tight construction or housed within a gas-tight enclosure, and are not located adjacent to a cargo tank bulkhead. The design of such fittings or their enclosures and the means by which cables enter, as well as any testing to

establish their gas-tightness, are to be to the satisfaction of the Society. The associated cables are to be protected by means of heavy gauge steel pipes with gas-tight joints.

1.8.3 (1/5/2013)

The explosion group and temperature class of electrical equipment of a certified safe type are to be at least IIA and T3 in the case of ships arranged for the carriage of crude oil or other petroleum products.

Other characteristics may be required for dangerous products other than those above.

1.8.4 (1/5/2013)

Enclosed or semi-enclosed spaces (not containing a source of hazard) having a direct opening, including those for ventilation, into any hazardous area, are to be designated as the same hazardous zone as the area in which the opening is located.

Electrical installations are to comply with the requirements for the space or area into which the opening leads.

Note 1: For openings, access and ventilation conditions affecting the extent of hazardous areas, see IEC Standard 60092-502.

1.9 Hazardous area classification

1.9.1 (1/6/2021)

For hazardous area classification see:

- a) Tab 1 for barge-oil carrying flammable liquids having:
 - a flash point not exceeding 60°C, or
 - a flash point exceeding 60°C, heated to a temperature above their flash point, or
 - a flash point exceeding 60°C, heated to a temperature within 15°C of their flash point;
- b) Tab 2 for barge-oil carrying flammable liquids having a flash point exceeding 60°C, unheated or heated to a temperature below and not within 15°C of their flash point.

Table 1 : Classification of hazardous areas for barge-oil carrying flammable liquids having a flash point not exceeding 60°C (1/5/2013)

Spaces		Hazardous area
N.	Description	
1	Interior of cargo tanks, slop tanks, any pipework of pressure relief or other venting systems for cargo and slop tanks, pipes and equipment containing cargo or developing flammable gases or vapours.	Zone 0
2	Void spaces adjacent to, above or below integral cargo tanks.	Zone 1
3	Hold spaces containing independent cargo tanks.	Zone 1
4	Cofferdams and permanent (for example, segregated) ballast tanks adjacent to cargo tanks.	Zone 1
5	Cargo pump rooms.	Zone 1
6	Enclosed or semi-enclosed spaces immediately above cargo tanks (e.g. 'tweendecks) or having bulkheads above and in line with cargo tank bulkheads, unless protected by a diagonal plate acceptable to the Society.	Zone 1
7	Spaces other than cofferdams, adjacent to and below the top of a cargo tank (e.g. trunks, passageways and holds) as well as double bottoms and pipe tunnels below cargo tanks.	Zone 1
8	Areas on open deck, or semi-enclosed spaces on open deck, within 3 m of any cargo tank outlet, gas or vapour outlet, cargo manifold valve, cargo valve, cargo pipe flange, cargo pump room ventilation outlets and cargo tank openings for pressure release provided to permit the flow of small volumes of gas or vapour mixtures caused by thermal variation.	Zone 1
9	Areas on open deck, or semi-enclosed spaces on open deck above and in the vicinity of any cargo gas outlet intended for the passage of large volumes of gas or vapour mixture during cargo loading and ballasting or during discharging, within a vertical cylinder of unlimited height and 6m radius centred upon the centre of the outlet, and within a hemisphere of 6m radius below the outlet.	Zone 1
10	Areas on open deck, or semi-enclosed spaces on open deck, within 1,5m of cargo pump room entrances, cargo pump room ventilation inlets, openings into cofferdams or other Zone 1 spaces.	Zone 1
11	Areas on open deck within spillage coamings surrounding cargo manifold valves and 3 m beyond these, up to a height of 2,4 m above the deck.	Zone 1
12	Areas on open deck over all cargo tanks (including all ballast tanks within the cargo tank area) where structures are restricting the natural ventilation and to the full breadth of the ship plus 3m fore and aft of the forward-most and aft-most cargo tank bulkhead, up to a height of 2,4m above the deck.	Zone 1
13	Compartments for cargo hoses.	Zone 1
14	Enclosed or semi-enclosed spaces in which pipes containing cargoes are located.	Zone 1

Spaces		Hazardous area
N.	Description	
15	Areas 2m beyond the area defined in item 8.	Zone 2
16	Areas of 1,5 m surrounding open or semi-enclosed spaces of Zone 1.	Zone 2
17	Areas 4m beyond the cylinder and 4m beyond the sphere defined in item 9.	Zone 2
18	Areas on open deck extending to the coamings fitted to keep any spills on deck and away from the accommodation and service areas and 3m beyond these up to a height of 2,4m above the deck.	Zone 2
19	Areas on open deck over all cargo tanks (including all ballast tanks within the cargo tank area) where unrestricted natural ventilation is guaranteed and to the full breadth of the ship plus 3m fore and aft of the forward-most and aft-most cargo tank bulkhead, up to a height of 2,4m above the deck surrounding open or semi-enclosed spaces of Zone 1.	Zone 2
20	Spaces forward of the open deck areas to which reference is made in item 12 and item 18, below the level of the main deck, and having an opening on the main deck or at a level less than 0,5m above the main deck, unless: <ul style="list-style-type: none"> a) the entrances to such spaces do not face the cargo tank area and, together with all other openings to the spaces, including ventilation system inlets and exhausts, are situated at least 5m from the fore-most cargo tank and at least 10m measured horizontally from any cargo tank outlet or gas or vapour outlet; and b) the spaces are mechanically ventilated. 	Zone 2

Table 2 : Hazardous areas classification for barge-oil carrying flammable liquids having a flash point exceeding 60°C unheated or heated to a temperature below and not within 15°C of their flash point (1/5/2013)

Spaces		Hazardous area
No.	Description	
1	Interior of cargo tanks, slop tanks, any pipework of pressure relief or other venting systems for cargo and slop tanks, pipes and equipment containing cargo.	Zone 2

2 Electrical installations for units with service notation "barge-accommodation"

2.1 Application

2.1.1 (1/7/2014)

The requirements in this item [2] apply, in addition to those contained in Part C, Chapter 2, to ships with the service notation **barge-accommodation**.

2.2 Documentation to be submitted

2.2.1 (1/7/2014)

The documentation dealing with the electrical system for watertight door and fire door systems is to be submitted for approval.

2.3 Electrical distribution and protection

2.3.1 (1/7/2014)

Distribution systems are to be so arranged that a fire in any main vertical zone as defined in Part C, Chapter 4 will not

interfere with services essential for safety in any other such zone.

This requirement will be met if main and emergency feeders passing through any such zone are separated both vertically and horizontally as widely as is practicable.

2.3.2 (1/7/2014)

For generators arranged to operate in parallel and for individually operating generators, arrangements are to be made to disconnect automatically the excess load when the generators are overloaded in such a way as to prevent a sustained loss of speed. The operation of such a device is to activate a visual and audible alarm.

2.3.3 (1/7/2014)

Supplementary lighting is to be provided in all cabins to clearly indicate the exit so that occupants will be able to find their way to the door. Such lighting, which may be connected to an emergency source of power or have a self-contained source of electrical power in each cabin, is to automatically illuminate when power to the normal cabin lighting is lost and remain on for a minimum of 30 min.

2.4 Control station

2.4.1 (1/7/2014)

Where the navigation bridge is not provided, all the control, alarm, indication and communication equipment is to be

centralized at a central control station which is to be continuously manned by a responsible member of the staff.

2.5 Main source of electrical power

2.5.1 (1/7/2014)

The main source of electrical power is to consist of at least two generating sets.

The capacity of these main sets is to be such that in the event of any one generating set being stopped it will still be possible to supply those services necessary to provide:

- a) normal operational conditions and safety;
- b) minimum comfortable conditions of habitability.

Minimum comfortable conditions of habitability include at least adequate services for lighting, cooking, heating, domestic refrigeration, mechanical ventilation, sanitary and fresh water; they also include refrigerators for air-conditioning, unless the unit is only operated in cold-temperate and cold areas.

Such capacity is, in addition, to be sufficient to start the largest motor without causing any other motor to stop or having any adverse effect on other equipment in operation.

2.5.2 (1/7/2014)

Pt C, Ch 2, Sec 3, [2.2.5] does not apply.

2.6 Emergency source of electrical power and emergency installations

2.6.1 General (1/7/2014)

- a) Provided that suitable measures are taken for safeguarding independent emergency operation under all circumstances, the emergency generator may be used, exceptionally, and for short periods, to supply non-emergency circuits.

Exceptionally, is understood to mean conditions such as:

- 1) blackout situation
 - 2) dead ship situation
 - 3) routine use for testing
 - 4) short-term parallel operation with the main source of electrical power for the purpose of load transfer.
- b) Pt C, Ch 2, Sec 3, [2.3.2] does not apply
 - c) The emergency source of electrical power is to be capable, having regard to starting currents and the transitory nature of certain loads, of supplying simultaneously at least the services stated in [2.6.2] a) for the period specified, if they depend upon an electrical source for their operation.
 - d) The transitional source of emergency electrical power, where required, is to be of sufficient capacity to supply at least the services stated in [2.6.2] d) for the periods specified therein, if they depend upon an electrical source for their operation.
 - e) An indicator is to be mounted in a suitable place on the main switchboard or in the machinery control room to indicate when the batteries constituting either the emergency source of electrical power or the transitional

source of emergency electrical power referred to in c) and d) are being discharged.

- f) If the services which are to be supplied by the transitional source receive power from an accumulator battery by means of semiconductor converters, means are to be provided for supplying such services also in the event of failure of the converter (e.g. providing a bypass feeder or a duplicate converter).
- g) Provision is to be made for the periodical testing of the complete emergency system and is to include the testing of automatic starting arrangements. Testing at regular intervals is to also cover load operation.
- h) The emergency source of electrical power may be either a generator or an accumulator battery, which are to comply with the provisions of i) or j), respectively.
- i) Where the emergency source of electrical power is a generator, it is to be:
 - 1) driven by a suitable prime mover with an independent supply of fuel having a flashpoint (closed cup test) of not less than 43°C;
 - 2) started automatically upon failure of the electrical supply to the emergency switchboard from the main source of electrical power and are to be automatically connected to the emergency switchboard; those services referred to in [2.6.2] a) shall then be transferred automatically to the emergency generating set. The automatic starting system and the characteristics of the prime mover are to be such as to permit the emergency generator to carry its full rated load as quickly as is safe and practicable, subject to a maximum of 45 s; and
 - 3) provided with a transitional source of emergency electrical power according to k).
- j) Where the emergency source of electrical power is an accumulator battery, it is to be capable of:
 - 1) carrying the emergency electrical load without recharging while maintaining the voltage of the battery throughout the discharge period within 12% above or below its nominal voltage;
 - 2) automatically connecting to the emergency switchboard in the event of failure of the main source of electrical power; and
 - 3) immediately supplying at least those services specified in [2.6.2] d).
- k) The transitional source of emergency electrical power required by i) (3) is to consist of an accumulator battery which is to operate without recharging while maintaining the voltage of the battery throughout the discharge period within 12% above or below its nominal voltage and be so arranged as to supply automatically in the event of failure of either the main or emergency source of electrical power at least the services in [2.6.2] d) if they depend upon an electrical source for their operation.

2.6.2 Distribution of electrical power (1/7/2014)

- a) The emergency source of electrical power is to be capable of supplying simultaneously at least the following services for the periods specified hereafter, if they depend upon an electrical source for their operation:

- 1) for a period of 36 hours, emergency lighting:
 - at every muster and embarkation station and over the sides;
 - in alleyways, stairways and exits giving access to the muster and embarkation stations;
 - in all service and accommodation alleyways, stairways and exits, personnel lift cars;
 - in the machinery spaces and main generating stations including their control positions;
 - in all control stations, machinery control rooms, and at each main and emergency switchboard;
 - at all stowage positions for firemen's outfits;
 - at emergency hospitals, if any;
 - at the fire pump, the sprinkler pump and the emergency bilge pump referred to in (d) below and at the starting position of their motors;
 - in all cabins, unless this supplementary lighting has a self-contained source of electrical power in each cabin;
- 2) for a period of 36 hours:
 - the navigation lights and other lights required by the International Regulations for Preventing Collisions at Sea in force; and
 - the radio installations
- 3) for a period of 36 hours:
 - all internal communication equipment required in an emergency (see b));
 - the fire detection and fire alarm system, the fire door holding and release system; and
 - intermittent operation of the daylight signalling lamp, the ship's whistle, the manually operated call points and all internal signals (see c)) that are required in an emergency,

unless such services have an independent supply for the period of 36 hours from an accumulator battery suitably located for use in an emergency;
- 4) for a period of 36 hours:
 - one of the fire pumps required by the relevant provisions of Part C, Chapter 4;
 - the automatic sprinkler pump, if any; and
 - the emergency bilge pump and all the equipment essential for the operation of electrically powered remote controlled bilge valves;
 - the sanitary and mechanical ventilation to provide minimum comfortable conditions of habitability;
- 5) for a period of half an hour:
 - any watertight doors required by Pt B, Ch 2, Sec 1, [6] to be power operated together with their indicators and warning signals;
 - the emergency arrangements to bring the lift cars to deck level for the escape of persons. The lift cars may be brought to deck level sequentially in an emergency.

- b) Internal communication equipment required in an emergency generally includes:
 - 1) the means of communication between the navigating bridge and the position in the machinery space or control room from which the engines are normally controlled
 - 2) the means of communication which is provided between the officer of the watch and the person responsible for closing any watertight door which is not capable of being closed from a central control station
 - 3) the public address system or other effective means of communication throughout the accommodation, public and service spaces
 - 4) the means of communication between the navigating bridge and the main fire control station.
- c) Internal signals required in an emergency generally include:
 - 1) general alarm
 - 2) watertight door indication
 - 3) Fire door indication.
- d) The transitional source of emergency electrical power required is to supply at least the following services if they depend upon an electrical source for their operation:
 - 1) for half an hour:
 - the lighting required by [2.6.2] a) 1) and a) 2);
 - all services required by [2.6.2] a) 3) first two bullets) unless such services have an independent supply for the period specified from an accumulator battery suitably located for use in an emergency.
 - 2) It is also to supply power to close the watertight doors as required by Pt B, Ch 2, Sec 1, [6], but not necessarily all of them simultaneously, unless an independent temporary source of stored energy is provided.
 - 3) Power to the control, indication and alarm circuits as required by Pt B, Ch 2, Sec 1, [6], for half an hour.

2.7 Escape lighting system

2.7.1 (1/7/2014)

In addition to the emergency lighting required in [2.6.2] a) 1), an escape lighting system is to be provided that is to be switched on automatically in the event of failure of the main and emergency power supply and that can operate for at least three hours.

Note 1: Alternatively, any other means of lighting which is at least as effective may be accepted by the Society.

2.7.2 (1/7/2014)

The escape lighting systems are to be supplied by batteries located within the lighting units that are continuously charged, where practicable, from the emergency switchboard.

Any failure of the lamp will be immediately apparent. Any accumulator battery provided is to be replaced at intervals

having regard to the specified service life in the ambient conditions that they are subject to in service.

2.7.3 (1/7/2014)

The escape lighting systems are to:

- a) illuminate all escape routes;
- b) illuminate lifeboat stations and the sea where life boats and life rafts are to be launched.

2.8 General emergency alarm and public address systems

2.8.1 General emergency alarm system (1/7/2014)

- a) Electrical cables and apparatus for the general emergency alarm system and their power supply are to be arranged so that the loss of the system in any one area due to localised fire is minimised.
- b) Where the fire alarm to summon the crew/staff operated from the navigating bridge or fire control station is part of the ship's general alarm system, it is to be capable of being sounded independently of the alarm in the public spaces.

2.8.2 Public address system (1/7/2014)

- a) The public address system is to be one complete system consisting of a loudspeaker installation which enables simultaneous broadcast of messages from the navigation bridge and at least one other location on board for use when the navigation bridge has been rendered unavailable due to the emergency, to all spaces where crew/staff members or guests, or both, are normally present (accommodation and service spaces and control stations and open decks), and to assembly stations (i.e. muster stations).
- b) The public address system is to be arranged to operate on the main source of electrical power, the emergency source of electrical power and transitional sources of electrical power as required by [2.6.2].
- c) The controls of the system on the navigation bridge are to be capable of interrupting any broadcast on the system from any other location on board.
- d) The system is not to require any action by the addressee.
- e) It is to be possible to address crew/staff accommodation and work spaces separately from guest spaces.
- f) In addition to any function provided for routine use aboard the ship, the system is to have an emergency function control at each control station which:
 - 1) is clearly indicated as the emergency function,
 - 2) is protected against unauthorised use,
 - 3) automatically overrides any other input system or program, and
 - 4) automatically overrides all volume controls and on/off controls so that the required volume for the emergency mode is achieved in all spaces.
- g) The system is to be installed with regard to acoustically marginal conditions, so that emergency announcements are clearly audible above ambient noise in all spaces where crew/staff members or guests, or both, are nor-

mally present (accommodation and service spaces and control stations and open decks), and at assembly stations (i.e. muster stations).

- h) With the ship in normal conditions, the minimum sound pressure level for broadcasting emergency announcements is to be:
 - 1) in interior spaces 75 dB (A) and at least 20 dB (A) above the speech interference level, and
 - 2) in exterior spaces 80 dB (A) and at least 15 dB (A) above the speech interference level.
- i) The system is to be arranged to prevent feedback or other interference.
- j) The system is to be arranged to minimise the effect of a single failure so that the emergency messages are still audible (above ambient noise levels) also in the event of failure of any one circuit or component.
- k) Each loudspeaker is to be individually protected against short-circuits.
- l) For cables used for the public address system, see Pt C, Ch 2, Sec 3, [9.6], Pt C, Ch 2, Sec 11, [5.2.1] and Pt C, Ch 2, Sec 11, [5.2.4].
- m) All areas of each fire zone are to be served by at least two dedicated loops of flame-retardant cables which are to be sufficiently separated throughout their length and supplied by two separate and independent amplifiers.

2.9 Installation

2.9.1 Section and distribution boards (1/7/2014)

Cubicles and cupboards in areas which are accessible to any guest are to be lockable.

2.10 Type approved components

2.10.1 (1/7/2014)

Components for Low-Location Lighting systems (LLL) in escape routes are to be type approved or in accordance with [2.10.2].

2.10.2 (1/7/2014)

Case-by-case approval based on the submission of adequate documentation and execution of tests may also be granted at the discretion of the Society.

3 Electrical installations for units with service notation "barge-chemical"

3.1 Application

3.1.1 (1/6/2021)

The requirements in this item [3] apply, in addition to those contained in Part C, Chapter 2, to barge-chemical.

3.2 Exemptions

3.2.1 (1/6/2021)

The requirements in Pt C, Ch 2, Sec 3, [2.2.1] and [2.3.1] are not applicable in the case of vessels without persons on board.

3.3 Documentation to be submitted

3.3.1 (1/6/2021)

In addition to the documentation requested in Pt C, Ch 2, Sec 1, Tab 1, the following are to be submitted for approval:

- a) plan of hazardous areas
- b) document giving details of types of cables and safety characteristics of the equipment installed in hazardous areas
- c) diagrams of tank level indicator systems, high level alarm systems and overflow control systems where requested.

3.4 System of supply

3.4.1 (1/6/2021)

Earthed systems with hull return are not permitted, with the following exceptions to the satisfaction of the Society:

- a) impressed current cathodic protective systems
- b) limited and locally earthed systems, such as starting and ignition systems of internal combustion engines, provided that any possible resulting current does not flow directly through any hazardous area
- c) insulation level monitoring devices, provided that the circulation current of the device does not exceed 30 mA under the most unfavourable conditions
- d) intrinsically safe systems.

3.4.2 (1/6/2021)

In insulated distribution systems, no current carrying part is to be earthed, other than:

- a) through an insulation level monitoring device
- b) through components used for the suppression of interference in radio circuits.

3.4.3 (1/6/2021)

The additional limitations in the choice of the system of supply (type of distribution system) as per SOLAS Ch.II-1 Reg. 45.4.3 apply to ships subject to the SOLAS Convention.

3.5 Electrical equipment

3.5.1 (1/6/2021)

Electrical equipment, cables and wiring are not to be installed in hazardous locations unless they conform with standards not inferior to those given in IEC 60092-502 Standard.

3.6 Earth detection

3.6.1 (1/6/2021)

For both insulated and earthed distribution systems a device, or devices, are to be installed to continuously monitor the insulation to earth and to give an audible and visual alarm at a manned position in the event of an abnormally low level of insulation resistance and/or high level of leakage current.

The above is not applicable to systems mentioned in [3.4.1].

3.7 Precautions against inlet of gases or vapours

3.7.1 (1/6/2021)

Suitable arrangements are to be provided, to the satisfaction of the Society, so as to prevent the possibility of gases or vapours passing from a gas-dangerous space to another space through runs of cables or their conduits.

3.8 Electrical equipment permitted in hazardous areas

3.8.1 (1/6/2021)

Electrical equipment permitted in hazardous areas is that indicated in Pt C, Ch 2, Sec 3, [10.1.4], Pt C, Ch 2, Sec 3, [10.1.5] and Pt C, Ch 2, Sec 3, [10.1.6].

3.8.2 (1/6/2021)

In addition to the requirements of [3.8.1], in Zone 1 and Zone 2 the installation of the following is permitted: hull fittings containing the terminals or shell plating penetrations for anodes or electrodes of an impressed current cathodic protection system, or transducers such as those for depth sounding or log systems, provided that such fittings are of gas-tight construction or housed within a gas-tight enclosure, and are not located adjacent to a cargo tank bulkhead. The design of such fittings or their enclosures and the means by which cables enter, as well as any testing to establish their gas-tightness, are to be to the satisfaction of the Society. The associated cables are to be protected by means of heavy gauge steel pipes with gas-tight joints.

3.8.3 (1/6/2021)

Enclosed or semi-enclosed spaces (not containing a source of hazard) having a direct opening, including those for ventilation, into any hazardous area, are to be designated as the same hazardous zone as the area in which the opening is located.

Electrical installations are to comply with the requirements for the space or area into which the opening leads.

Note 1: For openings, access and ventilation conditions affecting the extent of hazardous areas, see IEC Standard 60092-502.

3.9 Hazardous area classification

3.9.1 (1/6/2021)

For hazardous area classification see:

- a) Tab 1 for barge-oil carrying flammable liquids having:
 - a flash point not exceeding 60°C, or
 - a flash point exceeding 60°C, heated to a temperature above their flash point, or
 - a flash point exceeding 60°C, heated to a temperature within 15°C of their flash point;
- b) Tab 2 for barge-oil carrying flammable liquids having a flash point exceeding 60°C, unheated or heated to a temperature below and not within 15°C of their flash point.

4 Electrical installations for units with service notation "barge-liquefied gas" and units with service notation "barge-LNG Bunker"

4.1 Application

4.1.1 (1/6/2021)

The requirements in this item apply, in addition to those contained in Part C, Chapter 2, to ships with the service notation barge-liquefied gas and barge-LNG Bunker.

4.2 Exemptions

4.2.1 (1/6/2021)

The requirements in Pt C, Ch 2, Sec 3, [2.2.1] and [2.3.1] are not applicable in the case of vessels without persons on board.

4.3 Documentation to be submitted

4.3.1 (1/6/2021)

In addition to the documentation requested in Pt C, Ch 2, Sec 1, Tab 1, the following are to be submitted for approval:

- a) plan of hazardous areas
- b) document giving details of types of cables and safety characteristics of the equipment installed in hazardous areas
- c) diagrams of tank level indicator systems, high level alarm systems and overflow control systems where requested.

4.4 System of supply

4.4.1 (1/6/2021)

Earthed systems with hull return are not permitted, with the following exceptions to the satisfaction of the Society:

- a) impressed current cathodic protective systems
- b) limited and locally earthed systems, such as starting and ignition systems of internal combustion engines, provided that any possible resulting current does not flow directly through any hazardous area
- c) insulation level monitoring devices, provided that the circulation current of the device does not exceed 30 mA under the most unfavourable conditions
- d) intrinsically safe systems.

4.4.2 (1/6/2021)

In insulated distribution systems, no current carrying part is to be earthed, other than:

- a) through an insulation level monitoring device
- b) through components used for the suppression of interference in radio circuits.

4.4.3 (1/6/2021)

The additional limitations in the choice of the system of supply (type of distribution system) as per SOLAS Ch.II-1 Reg. 45.4.3 apply to ships subject to the SOLAS Convention.

4.5 Earth detection

4.5.1 (1/6/2021)

For both insulated and earthed distribution systems a device, or devices, are to be installed to continuously monitor the insulation to earth and to give an audible and visual alarm at a manned position in the event of an abnormally low level of insulation resistance and/or high level of leakage current.

The above is not applicable to systems mentioned in [4.4.1].

4.6 Precautions against inlet of gases or vapours

4.6.1 (1/6/2021)

Suitable arrangements are to be provided, to the satisfaction of the Society, so as to prevent the possibility of gases or vapours passing from a gas-dangerous space to another space through runs of cables or their conduits.

4.7 Electrical equipment permitted in hazardous areas

4.7.1 (1/6/2021)

Electrical equipment permitted in hazardous areas is that indicated in Pt C, Ch 2, Sec 3, [10.1.4], Pt C, Ch 2, Sec 3, [10.1.5][and Pt C, Ch 2, Sec 3, [10.1.6].

4.7.2 (1/6/2021)

In addition to the requirements of [4.7.1], in Zone 1 and Zone 2 the installation of the following is permitted: hull fittings containing the terminals or shell plating penetrations for anodes or electrodes of an impressed current cathodic protection system, or transducers such as those for depth sounding or log systems, provided that such fittings are of gas-tight construction or housed within a gas-tight enclosure, and are not located adjacent to a cargo tank bulkhead. The design of such fittings or their enclosures and the means by which cables enter, as well as any testing to establish their gas-tightness, are to be to the satisfaction of the Society. The associated cables are to be protected by means of heavy gauge steel pipes with gas-tight joints.

4.7.3 (1/6/2021)

Enclosed or semi-enclosed spaces (not containing a source of hazard) having a direct opening, including those for ventilation, into any hazardous area, are to be designated as the same hazardous zone as the area in which the opening is located.

Electrical installations are to comply with the requirements for the space or area into which the opening leads.

Note 1: For openings, access and ventilation conditions affecting the extent of hazardous areas, see IEC Standard 60092-502.

4.8 Hazardous area classification

4.8.1 (1/6/2021)

For hazardous area classification see Tab 3.

4.9 Submerged cargo pumps

4.9.1 Exception (1/6/2021)

Submerged cargo pumps are not permitted in connection with the following cargoes:

- diethyl ether
- vinyl ethyl ether
- ethylene oxide
- propylene oxide
- mixtures of ethylene oxide and propylene oxide.

4.9.2 Submerged electric motors (1/6/2021)

- a) Where submerged electric motors are employed, means are to be provided, e.g. by the arrangements specified in paragraph 17.6 of the IGC Code, to avoid the formation

of explosive mixtures during loading, cargo transfer and unloading.

- b) Arrangements are to be made to automatically shut down the motors in the event of low liquid level. This may be accomplished by sensing low pump discharge pressure, low motor current, or low liquid level. This shutdown is to be alarmed at the cargo control station. Cargo pump motors are to be capable of being isolated from their electrical supply during gas-freeing operations.

4.10 Product classification

4.10.1 Temperature class and explosion group (1/6/2021)

Tab 4 specifies temperature class and explosion group data for the products indicated in Chapter 19 of the IGC Code. The data shown in brackets have been derived from similar products.

Table 3 : Classification of hazardous areas for tankers carrying flammable liquefied gases (1/6/2021)

Spaces		Hazardous area
No.	Description	
1	Cargo containment systems	Zone 0
2	Hold spaces where cargo is carried in a cargo containment system requiring a secondary barrier	Zone 0
3	Hold spaces where cargo is carried in a cargo containment system not requiring a secondary barrier	Zone 1
4	Space separated from a hold space where cargo is carried in a cargo containment system requiring a secondary barrier by a single gas-tight steel boundary	Zone 1
5	Cargo pump and cargo compressor rooms	Zone 1
6	Areas on open deck, or semi-enclosed spaces on open deck, within 3 m of any cargo tank outlet, gas or vapour outlet, cargo manifold valve, cargo valve, cargo pipe flange, cargo pump and cargo compressor room ventilation outlets and cargo tank openings for pressure release provided to permit the flow of small volumes of gas or vapour mixtures caused by thermal variation	Zone 1
7	Areas on open deck, or semi-enclosed spaces on open deck above and in the vicinity of any cargo gas outlet intended for the passage of large volumes of gas or vapour mixture during cargo loading and ballasting or during discharging, within a vertical cylinder of unlimited height and 6 m radius centred upon the centre of the outlet, and within a hemisphere of 6 m radius below the outlet	Zone 1
8	Areas on open deck, or semi-enclosed spaces on open deck, within 1,5 m of cargo pump and cargo compressor room entrance, cargo pump and cargo compressor room ventilation inlet, openings into cofferdams or other zone 1 spaces	Zone 1
9	Areas on open deck within spillage coamings surrounding cargo manifold valves and 3 m beyond these, up to a height of 2,4 m above the deck	Zone 1
10	Areas on open deck over all cargo tanks (including ballast tanks within the cargo tank area) where structure restricts natural ventilation and to the full breadth of the ship plus 3 m fore and aft of the forward-most and aft-most cargo tank bulkhead, up to a height of 2,4 m above the deck	Zone 1
11	Compartment for cargo hoses	Zone 1
12	Enclosed or semi-enclosed spaces in which pipes containing cargoes are located	Zone 1
(1)	For ships subject to the SOLAS Convention, an area within 2m beyond the 3m of cargo tank ventilation outlets which permit the flow of small volumes of vapour gas mixtures caused by thermal variation is to be considered Zone 2	

Spaces		Hazardous area
No.	Description	
13	Enclosed or semi-enclosed spaces in which pipes containing cargo products for boil-off gas fuel burning systems are located, unless special precautions approved by the Society are provided to prevent product gas escaping into such spaces	Zone 1
14	Areas of 1,5 m surrounding open or semi-enclosed spaces of Zone 1 (1)	Zone 2
15	Areas 4 m beyond the cylinder and 4 m beyond the sphere defined in item 7	Zone 2
16	Spaces forming an air-lock	Zone 2
17	Areas on open deck extending to the coamings fitted to keep any spills on deck and away from the accommodation and service areas and 3m beyond these up to a height of 2,4m above the deck	Zone 2
18	Areas on open deck over all cargo tanks (including all ballast tanks within the cargo tank area) where unrestricted natural ventilation is guaranteed and to the full breadth of the ship plus 3 m fore and aft of the forward-most and aft-most cargo tank bulkhead, up to a height of 2,4 m above the deck surrounding open or semi-enclosed spaces of Zone 1	Zone 2
19	Spaces forward of the open deck areas to which reference is made in item 10 and item 18, below the level of the main deck, and having an opening on the main deck or at a level less than 0,5 m above the main deck, unless: a) the entrances to such spaces do not face the cargo tank area and, together with all other openings to the spaces, including ventilation system inlets and exhausts, are situated at least 5 m from the foremost cargo tank and at least 10 m measured horizontally from any cargo tank outlet or gas or vapour outlet; and b) the spaces are mechanically ventilated	Zone 2
20	Areas within 2,4 m of the outer surface of a cargo tank where such surface is exposed to the weather	Zone 2
(1) For ships subject to the SOLAS Convention, an area within 2m beyond the 3m of cargo tank ventilation outlets which permit the flow of small volumes of vapour gas mixtures caused by thermal variation is to be considered Zone 2		

Table 4 : Temperature class and explosion group of certain products (1/6/2021)

Product name	Temperature class	Explosion group	Product name	Temperature class	Explosion group
Acetaldehyde	T4	II A	Methane	T1	II A
Ammonia anhydrous	T1	II A	Methyl acetylene propadiene mixture	T4	II A
Butadiene	T2	II B	Methyl bromide	T3	II A
Butane	T2	II A	Methyl chloride	T1	II A
Butane/propane mixture	T2	II A	Monoethylamine	T2	II A
Butylenes	T3	II A	Nitrogen	NF	NF
Chlorine	NF	NF	Pentane (all isomers)	(T2)	(II A)
Diethyl ether	T4	II B	Pentene (all isomers)	(T3)	(II B)
Dimethylamine	T2	II A	Propane	T2	II A
Ethane	T2	II A	Propylene	T2	II B
Ethyl chloride	T2	II A	Propylene oxide	T2	II B
Ethylene	T2	II B	Refrigerant gases	NF	NF
Ethylene oxide	T2	II B	Sulphur dioxide	(T3)	(II B)

Pt E, Ch 19, Sec 8

Product name	Temperature class	Explosion group	Product name	Temperature class	Explosion group
Ethylene oxide propylene oxide mixture (max. 30% mass/mass ethylene oxide)	T2	II B	Vinyl chloride	T2	II A
Isoprene	T3	II B	Vinyl ethyl ether	T3	II B
Isopropylamine	T2	II A	Vinylidene chloride	T2	II A

Part E
Service Notations

Chapter 20
FISHING VESSELS

- SECTION 1 GENERAL**
- SECTION 2 SHIP ARRANGEMENT**
- SECTION 3 HULL AND STABILITY**
- SECTION 4 MACHINERY**
- SECTION 5 ELECTRICAL INSTALLATIONS**

SECTION 1 GENERAL

1 General

1.1 Application

1.1.1 Ships complying with the requirements of this Chapter are eligible for the assignment of the service notation **fishing vessel**, as defined in Pt A, Ch 1, Sec 2, [4.10].

1.1.2 Ships dealt with in this Chapter are to comply with the requirements stipulated in Parts A, B, C and D, as applicable, and with the requirements of this Chapter, which are specific to fishing vessels.

1.2 Summary table

1.2.1 Tab 1 indicates, for ready reference, the Sections of this Chapter containing specific requirements applicable to fishing vessels.

Table 1 (1/1/2007)

Main subject	Reference
Ship arrangement	Sec 2
Hull and stability	Sec 3
Machinery	Sec 4
Electrical installations	Sec 5
Automation	(1)
Fire protection, detection and extinction	(1)
(1) No specific requirements for fishing vessels are given in this Chapter.	

SECTION 2 SHIP ARRANGEMENT

1 General arrangement design

1.1 Subdivision arrangement

1.1.1 General

Fishing vessels are to be fitted with at least the following transverse watertight bulkheads:

- one collision bulkhead
- one after peak bulkhead
- two bulkheads forming the boundaries of the machinery space in ships with machinery amidships, and a bulkhead forward of the machinery space in ships with machinery aft.

1.1.2 Disposition of collision bulkhead (1/7/2006)

For vessels equal to or greater than 45 m in length, the collision bulkhead is to be located at a distance from the forward perpendicular FP_{LL} of not less than 5% and no more than 8% of the length L_{LL} of the ship.

For vessels less than 45 m in length, the collision bulkhead is to be located at a distance from the forward perpendicular FP_{LL} of not less than 5% of the length L_{LL} of the ship and not more than 5% of the length $L_{LL} + 1,35$ m. In no case is this distance to be less than 2 m. For vessels less than 24 m in length it is not necessary that the minimum distance is 2 m. In any case for vessels less than 12 m in length with navigation notation up to "coastal area" it is not necessary to install a collision bulkhead.

Where any part of the ship below the waterline extends forward of the forward perpendicular, e.g a bulbous bow, the above distances, in m, are to be measured from a point either:

- at the mid-length of such extension, or
- at a distance 1,5% of the length L_{LL} of the ship forward of the forward perpendicular, where this distance is lesser.

1.1.3 Height of transverse watertight bulkheads (1/7/2006)

The bulkheads in [1.1.1] are to be watertight up to the working deck.

Where a long forward superstructure is fitted, the collision bulkhead is to be extended weathertight to the next deck above the freeboard deck. The extension need not be fitted directly above the bulkhead below provided it is located within the limits prescribed in [1.1.2] and the part of the deck which forms the step is made effectively watertight.

1.1.4 Openings in collision bulkhead

Openings in the collision bulkhead below the working deck are not allowed.

Where penetration of the collision bulkhead is necessary for piping, arrangements are to be fitted to maintain the watertight integrity and strength, with suitable valves operable from above the freeboard deck, whose valve chest is to be secured at the bulkhead inside the fore peak.

Where the collision bulkhead extends above the working deck, openings above the working deck are allowed provided that they are supplied with weathertight means of closure.

1.1.5 Openings in watertight bulkheads

The number of openings in watertight bulkheads is to be kept to a minimum compatible with the design and proper working of the ship.

Where penetration of watertight bulkheads and internal decks is necessary for access, piping, ventilation, electrical cables, etc., arrangements are to be fitted to maintain the watertight integrity and strength.

1.2 Cofferdams

1.2.1 Cofferdams are to be provided between compartments intended for liquid hydrocarbons (fuel oil, lubricating oil) and those intended for fresh water or boiled feed water.

1.2.2 Cofferdams separating fuel oil tanks from lubricating oil tanks and such tanks from those intended for the carriage of fresh water or boiler feed water may not be required when deemed impracticable or unreasonable by the Society in relation to the characteristics and dimensions of such tanks, provided that:

- the thickness of common boundary plates of adjacent tanks is increased by 1 mm with respect to that obtained according to Pt B, Ch 7, Sec 1
- the tank structural test is carried out with a head increased by 1 m with respect to that specified in Pt B, Ch 12, Sec 3, [2].

1.2.3 Spaces intended for the carriage of flammable liquids are to be separated from accommodation and service spaces by means of a cofferdam. Where accommodation and service spaces are arranged immediately above such spaces, the cofferdam may be omitted only where the deck is not provided with access openings and is coated with a layer of material recognised as suitable by the Society.

The cofferdam may also be omitted where such spaces are adjacent to a passageway, subject to the conditions in [1.2.2] for the avoidance of cofferdams between fuel oil and lubricating oil tanks.

2 Bow height

2.1 Vessels of not less than 24 m in length

2.1.1 (1/7/2006)

For vessels of not less than 24 m in length the following requirements are to be applied:

- a) where, during the fishing operations, the catch is to be stowed in fish holds through hatchways which are situated on an exposed working deck forward of the deck-house or superstructure, the minimum bow height is to be calculated in accordance with the following method:
 - 1) the bow height is defined as the minimum vertical distance from the deepest waterline to the top of the highest exposed deck measured at the forward perpendicular;
 - 2) the determination of the bow height (H_B) required may be based upon the following formula:

$$H_B = K_1 L \cdot \left(1 + \frac{L}{K_2}\right)$$

where:

L is the length of the vessel, in m;

K_1 and K_2 are coefficients depending upon the areas of operation and L as in Tab 1;

- 3) for vessels with navigation notation "coastal area" the value of the bow height calculated according to the formula in a) 2) may be reduced by 15%;
- 4) where the bow height required is obtained by sheer, this is to be extended from the stem for a length of at

least 0,15 L abaft the forward perpendicular, or, if a forecastle is fitted it is to be extended for a length of at least 0,07 L abaft the forward perpendicular;

- b) where, during the fishing operation, the catch is to be stowed in fish holds through hatchways which are situated on an exposed working deck protected by a deck-house or superstructure, the minimum bow height is to be in accordance with Regulation 39 of Annex I to the International Loadline Convention 1966, but is to be not less than 2000 mm. In this respect the maximum permissible operating draught is to be used in place of the assigned summer freeboard for the purpose of determining the minimum bow height.

2.2 Vessels of length less than 24 m

2.2.1 (1/7/2006)

For vessels of length less than 24 m and having navigation notation greater than "coastal area", the bow height is to be not less than the following:

$$H_B = 0,09L \cdot \left(1 - \frac{L}{270}\right)$$

For the evaluation of H_B the same requirements as stated in [2.1.1]a)3) and [2.1.1]a)4) may be applied.

2.2.2 (1/7/2006)

For vessels less than 24 m in length and having navigation notation "coastal area", the minimum freeboard height is to be not less than 0,1 B. In any case such value is to be not less than 0,30 m.

Table 1 (1/7/2006)

Area of operation	L	K_1	K_2
Extreme conditions with significant wave height up to and including 8 m	$24 \leq L \leq 110$ m	0,09	- 270
	$L > 110$ m	$4,959/L$	600
Extreme conditions with significant wave height above 8 m	$24 \leq L \leq 110$ m	0,117	- 220
	$L > 110$ m	$5,991/L$	1484

SECTION 3 HULL AND STABILITY

Symbols

x, y, z : X, Y and Z co-ordinates, in m, of the calculation point with respect to the reference co-ordinate system defined in Pt B, Ch 1, Sec 2, [4]

k : Material factor for steel, defined in Pt B, Ch 4, Sec 1, [2.3]

p_E : Side and bottom design pressure, in kN/m², for ships less than 65 m in length, to be obtained from the following formula:

$$p_E = 5L^{1/3} \left[1 - \frac{(T-z)}{2T} \right] + 10(T-z) + p_A \quad \text{for } z \leq T$$

$$p_E = (5L^{1/3} + p_A) \frac{10}{10 + (z-T)} \quad \text{for } z > T$$

p_A : Additional pressure, in kN/m², for ships less than 65 m in length, to be obtained from the following formulae:

$$p_A = 0,17L - 1,7x \quad \text{for } 0 \leq x < 0,1L$$

$$p_A = 0 \quad \text{for } 0,1L \leq x < 0,8L$$

$$p_A = 2,25(x - 0,8L) \quad \text{for } 0,8L \leq x \leq L$$

p_D : Bottom design pressure, in kN/m², for ships less than 65 m in length, to be obtained from the following formulae:

$$p_D = \max(10T; 6,6D) \quad \text{for } T/D \geq 0,5$$

$$p_D = 10T + 2,5L^{1/3} + p_A \quad \text{for } T/D < 0,5$$

p_L : Liquid design pressure, for ships less than 65 m in length, to be taken as the greater of the values obtained, in kN/m² from the following formulae:

$$p_L = 10[(h_a + z_{TOP}) - z]$$

$$p_L = 10 \left[\frac{2}{3}(z_{AP} - z) \right]$$

h_a : Distance, to be obtained, in m, from the following formula:

$$h_a = 1 + 0,05(L - 50) \quad \text{without being taken less than 1m,}$$

z_{TOP} : Z co-ordinate, in m, of the highest point of the tank in the z direction

z_{AP} : Z co-ordinate, in m, of the top of the air pipe of the tank in the z direction

s : Length, in m, of the shorter side of the plate panel or spacing, in m, of ordinary stiffeners, or spacing, in m, of primary supporting members, as applicable

ℓ : Length, in m, of the longer side of the plate panel or span, in m, of ordinary stiffeners, measured between the supporting members, or span, in m, of primary supporting members, as applicable (to be taken according to Pt B, Ch 4, Sec 3, [3.2] and Pt B, Ch 4, Sec 3, [4.1]).

1 Stability

1.1 Intact stability

1.1.1 Application

The stability of the ship for the loading conditions in Pt B, Ch 3, App 2, [1.2.13], with the assumptions in [1.1.2], is to be in compliance with the requirements in [1.1.3].

1.1.2 Assumptions for calculating loading conditions

The assumptions for calculating the loading conditions in Pt B, Ch 3, App 2, [1.2.13] are as follows:

- allowance is to be made for the weight of the wet fishing nets and tackle, etc., on deck
- allowance for icing, where this is anticipated to occur, is to be made in accordance with Pt B, Ch 3, Sec 2, [6]
- in all cases the cargo is to be assumed to be homogeneous unless this is inconsistent with practice
- deck cargo is to be included if such a practice is anticipated
- water ballast is normally to be included only if carried in tanks which are specially provided for this purpose.

1.1.3 Intact stability criteria

- The general intact stability criteria in Pt B, Ch 3, Sec 2, [2] are to be applied to fishing vessels equal to or greater than 24 m in length, except for the requirements below.
- The initial metacentric height GM_o is to be not less than 0,35 m for single deck vessels.
- The metacentric height GM_o may be reduced to the satisfaction of the Society but in no case is GM_o to be less than 0,15 m for vessels with complete superstructure or vessels equal to or greater than 70 m in length.

Where arrangements other than bilge keels are provided to limit the angle of roll, the above stability criteria are to be maintained in all operating conditions.

1.1.4 Relaxation of the Rules for ships of length $L < 24$ m (1/7/2003)

For decked ships of length less than 20 m, when a practical stability test has been carried out as foreseen in Pt B, Ch 3, Sec 1, [3.2], the initial metacentric height GM_o is to be not less than 0,50 m in all the expected loading conditions during the ship's service.

For ships without decks, the residual freeboard on the heeled side due to the practical crowding test is to be not less than 0,20 m.

For ships of length less than 24 m, the requirements relevant to the righting arm diagrams need not be complied with; in any event, for ships of length greater than 20 m, the inclin-

ing experiment is to be carried out and the booklet with instructions for the Master is to be prepared.

1.1.5 Severe wind and rolling criterion (weather criterion)

The requirements in Pt B, Ch 3, Sec 2, [3] are to be complied with by:

- fishing vessels equal to or greater than 45 m in length
- fishing vessels in the length range between 24 m and 45 m, with the values of wind pressure defined in Tab 1, depending on the vertical distance h , in m, measured from the centre of the projected vertical area of the ship above the waterline to the waterline.

Table 1 : Values of wind pressure

Vertical distance h , in m	Wind pressure, in kN/m ²
1	0,316
2	0,386
3	0,429
4	0,460
5	0,485
6 and over	0,504

1.1.6 Icing

For vessels operating in areas where ice accretion is expected, the requirements in Pt B, Ch 3, Sec 2, [6] are to be complied with.

2 Hull scantlings of ships equal to or greater than 65 m in length

2.1 Plating

2.1.1 The net thickness of bottom, side and deck plating is to be increased by 0,5 mm with respect to that calculated according to Pt B, Ch 7, Sec 1 or Pt B, Ch 8, Sec 3, as applicable.

2.2 Aft ramp

2.2.1 Plating of the aft ramp and the lower part of the aft ramp side

The net thickness of plating of the aft ramp and the lower part of the aft ramp side is to be increased by 2 mm with respect to that calculated according to Pt B, Ch 9, Sec 2, [3] for side plating with the same plate panel dimensions.

In any case, these net thicknesses are to be not less than 11mm.

2.2.2 Plating of the upper part of the aft ramp side

The net thickness of plating of the upper part of the aft ramp side is to be not less than the value calculated according to Pt B, Ch 9, Sec 2, [3] for side plating with the same plate panel dimensions.

3 Hull scantlings of ships less than 65 m in length

3.1 General

3.1.1 Application

The requirements in [3.1] to [3.12] apply to structures located aft of the collision bulkhead. The remaining requirements of [3] apply to other items, as specified.

3.1.2 Scantling reduction depending on the navigation notation

The requirements of [3] apply for the structural scantling of ships having the **unrestricted navigation** notation.

For ships with restricted navigations, the required scantling may be reduced by the percentages specified in Tab 2, depending on the navigation notation assigned to the ship.

Table 2 : Scantling reduction percentages depending on the navigation notation

Navigation notation	Reduction
Summer zone	5%
Tropical zone Coastal area	10%
Sheltered area	16%
Note 1: For sternframes, bulkheads and decks, 50% of the reduction applies.	

3.1.3 Gross scantling

All scantlings referred to in [3] are gross, i.e. they include the margins for corrosion.

3.2 Longitudinally framed single bottom

3.2.1 Scantlings of plating, ordinary stiffeners and primary supporting members

The scantlings of plating, ordinary stiffeners and primary supporting members are to be not less than both the values obtained from the formulae in Tab 3 and the minimum values in the table.

3.3 Transversely framed single bottom

3.3.1 Scantlings of plating, ordinary stiffeners and primary supporting members

The scantlings of plating, ordinary stiffeners and primary supporting members are to be not less than both the values obtained from the formulae in Tab 4 and the minimum values in the table.

3.4 Bilge

3.4.1 Bilge plating thickness

The thickness of bilge plating is to be not less than that of the adjacent bottom or side plating, whichever is the greater.

Table 3 : Scantlings of longitudinally framed single bottom structures

Element	Formulae	Minimum value
Plating	Thickness, in mm (1) : $t = 7,2 s (TK)^{1/2}$	Minimum thickness, in mm: $t = 0,06 Lk^{0.5} + 4,0$
Ordinary stiffeners	Section modulus, in cm ³ : $w = 0,8 s \ell^2 p_D k$	
Floors	Section modulus, in cm ³ : $w = s \ell^2 p_D k$	Minimum web plate thickness, in mm: $t = 6,0$
Girders (2)	Web thickness, in mm: <ul style="list-style-type: none"> • $t = 0,06 Lk^{1/2} + 5,0$ for centre girders • $t = 0,06 Lk^{1/2} + 4,0$ for side girders. 	
		Minimum face plate area, in cm ² : <ul style="list-style-type: none"> • $A = 8,0$ for centre girders • $A = 5,0$ for side girders.
	Where considered as floor supports, section modulus, in cm ³ : $w = s \ell^2 p_D k$	
(1) For ships equal to or greater than 30 m in length, this thickness may be gradually tapered such as to reach, at the collision and after peak bulkheads, 80% of the value obtained from this formula, without being less than 5 mm.		
(2) For ships equal to or greater than 30 m in length, the web thickness and the flange area may be gradually tapered such as to reach, at the collision and after peak bulkheads, 80% of the values obtained from these formulae.		

Table 4 : Scantlings of transversely framed single bottom structures

Element	Formula	Minimum value
Plating	Thickness, in mm (1) : $t = 8,5 s (TK)^{1/2}$	Minimum thickness, in mm: $t = 0,06 Lk^{1/2} + 4,0$
Floors	Section modulus, in cm ³ (2) : $w = 0,43 s \ell^2 p_D k$ Web plate thickness, in mm: $t = 10 h_w + 2,0$	
Girders (3)	Web thickness, in mm: <ul style="list-style-type: none"> • $t = 0,06 Lk^{1/2} + 5,0$ for centre girders • $t = 0,06 Lk^{1/2} + 4,0$ for side girders. 	
		Minimum face plate area, in cm ² : <ul style="list-style-type: none"> • $A = 8,0$ for centre girders • $A = 5,0$ for side girders.
Note 1: h_w : Height, in m, of floors at the centreline to be taken not less than $B/16$.		
(1) For ships equal to or greater than 30 m in length, this thickness may be gradually tapered such as to reach, at the collision and after peak bulkheads, 80% of the value obtained from this formula, without being less than 5 mm.		
(2) For ordinary stiffeners located within the engine room area, the required section modulus is to be increased by 40% with respect to that obtained from this formula.		
(3) For ships equal to or greater than 30 m in length, the web thickness and the flange area may be gradually tapered such as to reach, at the collision and after peak bulkheads, 80% of the values obtained from these formulae.		

3.5 Double bottom

3.5.1 Scantlings of plating, ordinary stiffeners and primary supporting members

The scantlings of plating, ordinary stiffeners and primary supporting members are to be not less than both the values obtained from the formulae in Tab 5 and the minimum values in the table.

3.6 Open floors in transversely framed double bottom

3.6.1 Frames

The section modulus of frames constituting open floors is to be not less than the value obtained, in cm^3 , from the following formula:

$$w = 0,8s\ell^2p_D$$

where:

ℓ : Span, in m, of transverse ordinary stiffeners constituting the open floor (see Pt B, Ch 4, Sec 3, [3.2.2]).

3.6.2 Reverse frames

The section modulus of reverse frame constituting open floors is to be not less than the value obtained, in cm^3 , from the following formula:

$$w = 0,7s\ell^2p_D$$

where:

ℓ : as indicated in [3.6.1].

3.7 Side

3.7.1 Sheerstrake width

For ship greater than 20 m in length, the width of the sheerstrake is to be not less than the value obtained, in mm, from the following formula:

$$b = 500 + 100 D$$

3.7.2 Plating, ordinary stiffeners and primary supporting members

The scantlings of plating, ordinary stiffeners and primary supporting members are to be not less than both the values obtained from the formulae in Tab 6 and the minimum values in the table.

3.7.3 Sheerstrake thickness

For ship greater than 20 m in length, the thickness of the sheerstrake is to be increased by 1 mm with respect to that obtained from the formulae in [3.7.2]. In any case, it is to be not less than that of the stringer plate.

3.8 Decks

3.8.1 Stringer plate width

The width of the stringer plate is to be not less than the value obtained, in mm, from the following formula:

$$b = 800 + 5 L$$

3.8.2 Minimum scantlings of pillars

The thickness, in mm, of hollow (tubular or rectangular) pillars is to be not less than the greater of 5 mm and $d / 35$, where d is the nominal diameter, in mm, for tubular pillar cross-sections or the larger side, in mm, for rectangular pillar cross-sections.

The thickness, in mm, of the face plate of built-up pillars is to be not less than $b_f / 36$, where b_f is the face plate width, in mm.

3.8.3 Scantlings of plating, ordinary stiffeners and primary supporting members

The scantlings of plating, ordinary stiffeners and primary supporting members are to be not less than both the values obtained from the formulae in Tab 8 and the minimum values in the table.

Table 5 : Scantlings of double bottom structures

Element	Formula	Minimum value
Bottom plating	As specified in: <ul style="list-style-type: none"> [3.2] for longitudinally framed structure [3.3] for transversely framed structure. 	Minimum thickness, in mm: $t = 0,06 Lk^{1/2} + 4,0$
Bottom ordinary stiffeners	Section modulus, in cm^3 : $w = 0,8 s \ell^2 p_D k$	
Inner bottom plating	Thickness, in mm, the greater of: (1) (2) (3) : <ul style="list-style-type: none"> $t = 0,04 Lk^{1/2} + 5 s + 2$ $t = 1,35s(p_L k)^{1/2}$ (6) 	Minimum thickness, in mm: $t = 5,0$
Inner bottom ordinary stiffeners	Section modulus, in mm, the greater of: <ul style="list-style-type: none"> $w = 0,8 s \ell^2 p_D k$ $w = 0,465s\ell^2 p_L k$ (6) 	
Centre girder	Web thickness, in mm (4) : $t = \frac{22B + 25(T + 10)}{100} k^{0,5} + 4$	Minimum web thickness, in mm: $t = 6,0$
Side girders	Web thickness, in mm (4) : <ul style="list-style-type: none"> For transversely framed structure: $t = \frac{22B + 25(T + 10)}{100} k^{0,5} + 3$ For longitudinally framed structure: $t = 0,054 Lk^{1/2} + 4,5$ 	Minimum web thickness, in mm: $t = 6,0$
Floors	Web thickness, in mm (5) : $t = f_s \left(\frac{22B + 25(T + 10)}{100} k^{0,5} + 1 \right)$	Minimum web thickness, in mm: $t = 6,0$
Note 1:		
f_s : Coefficient to be taken equal to: <ul style="list-style-type: none"> 1,1 for longitudinally framed structure 1,0 for transversely framed structure. 		
(1) For ships equal to or greater than 30 m in length, this thickness may be gradually tapered such as to reach, at the collision and after peak bulkheads, 90% of the value obtained from this formula.		
(2) For plating located within the engine room area, this thickness is to be increased by 10% with respect to that obtained from this formula.		
(3) For margin plates inclined downward with respect to the inner bottom plating, this thickness is to be increased by 20% with respect to that obtained from this formula.		
(4) For ships equal to or greater than 30 m in length, this thickness may be gradually tapered such as to reach, at the collision and after peak bulkheads, a thickness reduced by 2 mm with respect to that obtained from this formula.		
(5) For floors located within the engine room with transversely framed structure, this thickness is to be increased by 1 mm with respect to that obtained from this formula.		
(6) To be considered only for double bottoms intended for the carriage of ballast.		

Table 6 : Scantlings of side structures

Element	Formula	Minimum value
Plating	Thickness, in mm (1) : <ul style="list-style-type: none"> for longitudinally framed structure: $t = 6,1 s (TK)^{1/2}$ for transversely framed structure: $t = 7,2 s (TK)^{1/2}$ 	Minimum thickness, in mm: $t = 4,0$
Ordinary stiffeners	Section modulus, in cm ³ : <ul style="list-style-type: none"> for longitudinal ordinary stiffeners: $w = 0,675 s \ell^2 p_c k$ for transverse frames (2) : $w = 0,75 s \ell^2 p_H f_c R k$ 	Minimum section modulus, in cm ³ : $w = 20$
Primary supporting members	Section modulus, in cm ³ : <ul style="list-style-type: none"> for longitudinal and vertical primary supporting members: $w = K_{CR} s \ell^2 p_H k$ in addition, for vertical primary supporting members not associated with side girders, in ships with a transversely framed side: $w = 0,75 s \ell^2 \left(p_E + \frac{n_s h_2 B}{12} \right) k$ 	
<p>Note 1:</p> <p>p_H : Design pressure, in kN/m², to be obtained from the following formula: $p_H = p_E + 0,083 h_2 B$ For transverse frames of 'tweendecks':</p> <ul style="list-style-type: none"> p_H is to be taken not less than $0,37L$ where the upper end is located below the full load waterline p_H is to be taken not less than $0,23L - 2d_p$ where the upper end is located above the full load waterline and aft of the collision bulkhead p_H is to be taken not less than $0,3L$ where the upper end is located above the full load waterline and forward of the collision bulkhead. <p>d_p : Vertical distance, in m, measured between the design deck (first deck above the full load waterline extending for at least $0,6L$) and the deck above the frame</p> <p>h_2 : Sum of the heights, in m, of all 'tweendecks above the deck located at the top of the frame without being taken less than $2,5m$; for 'tweendecks intended as accommodation decks and located above the design deck (first deck above the full load waterline extending for at least $0,6L$), half of the height may be taken; for 'tweendecks above a deck which is longitudinally framed and supported by deck transverses, a height equal to 0 may be taken</p> <p>f_c : Coefficient depending on the type of connection and the type of frame as defined in Tab 7</p> <p>R : Coefficient depending on the location of the ordinary stiffeners:</p> <ul style="list-style-type: none"> $R = 0,8$ for ordinary stiffeners in hold and engine room $R = 1,4$ for ordinary stiffeners in 'tweendecks. <p>K_{CR} : Coefficient to be taken equal to:</p> <ul style="list-style-type: none"> $K_{CR} = 0,4$ for vertical primary supporting members located outside machinery spaces and not associated with side girders, in ships with a transversely framed side $K_{CR} = 0,5$ for vertical primary supporting members located inside machinery spaces and not associated with side girders, in ships with a transversely framed side $K_{CR} = 0,9$ in other cases. <p>n_s : Number of transverse ordinary stiffener spaces between vertical primary supporting members.</p> <p>(1) For ships equal to or greater than 30 m in length, this thickness may be gradually tapered such as to reach, at the collision and fore peak bulkheads, 80% of the value obtained from this formula, without being less than 5 mm.</p> <p>(2) Where the span is the same, it is not necessary to assume a section modulus of 'tweendeck frame greater than that of the frame below.</p>		

Table 7 : Coefficient f_c

Type of connection	Type of frame	f_c
Brackets at both ends	Hold frames	0,62
	'Tweendeck frames	0,80
Bracket at one end and without bracket at the other	Hold or 'tweendeck frames	1,20
Without brackets at both ends	Hold or 'tweendeck frames	1,20

3.8.4 Scantlings of pillars subjected to compressive axial load

The area of solid, tubular or prismatic pillars made of steel, having ultimate minimum tensile strength within the range 400-490 N/mm², and of pillars consisting of hollow profiles made of steel, having ultimate minimum tensile strength within the range 400-540 N/mm², subjected to compression axial load is to be not less than the value obtained, in cm², from the following formula:

$$A = \frac{0,7A_D p_2 + Q_N}{12,5 - 0,045\lambda}$$

where:

- p_2 : Design pressure, in kN/m², to be taken equal to:
- the greater of:

$$p_2 = 3,0$$

$$p_2 = 1,3 p_1$$

for pillars located below exposed deck areas

- $p_2 = 0,6 p_0$, for pillars located below unexposed accommodation areas and above the strength deck
- $p_2 = p_0$ in other cases

p_0, p_1 : Design pressures, in kN/m², defined in Tab 9

λ : Slenderness of the pillar, to be obtained from the following formula:

$$\lambda = 100 \ell / \rho$$

ρ : Minimum radius of gyration, in cm, of the pillar cross-section

A_D : Area, in m², of the portion of the deck supported by the pillar considered

Q_N : Load from pillar above, in kN, if any, or any other concentrated load

d : Nominal diameter, in mm, for tubular pillar cross-sections or the larger side, in mm, for rectangular pillar cross-sections

b_f : face plate width, in mm

Scantlings of pillars other than those above are to be considered by the Society on a case-by-case basis.

Table 8 : Scantlings of deck structures

Element	Formula	Minimum value
Strength deck plating	Thickness, in mm (1) : <ul style="list-style-type: none"> $t = 5 s + 0,022 Lk^{1/2} + 2,5$ for longitudinally framed structure $t = 6 s + 0,026 Lk^{1/2} + 3,0$ for transversely framed structure. 	Minimum thickness, in mm: $t = 6,0$
Lower deck and platform plating	Thickness, in mm (1) : <ul style="list-style-type: none"> for longitudinally framed structure, the greater of: <ul style="list-style-type: none"> $t = 5 s + 0,022 Lk^{1/2} + 1,5$ $t = 10 s$ for transversely framed structure, the greater of: <ul style="list-style-type: none"> $t = 6 s + 0,026 Lk^{1/2} + 2,0$ $t = 10 s$ 	Minimum thickness, in mm: $t = 5,0$
Ordinary stiffeners	Section modulus, in cm ³ : $w = 0,45 C_1 s \ell^2 (p_0 + p_1) k$	
Primary supporting members	Section modulus, in cm ³ : $w = 0,1 C_2 C_3 s \ell^2 (p_0 + p_1) k$ Moment of inertia, in cm ⁴ : $I = 2,5 w \ell$	

Note 1:

p_0, p_1 : Design pressure, in kN/m², defined in Tab 9

C_1 : Coefficient, defined in Tab 10

C_2 : Coefficient, defined in Tab 11

C_3 : Coefficient equal to:

- $C_3 = 1,00$ for weather deck area located forward of the collision bulkhead
- $C_3 = 0,50$ in other cases.

(1) For ships equal to or greater than 30 m in length, this thickness may be gradually tapered such as to reach, at the collision bulkhead, 80% of the value obtained from this formula.

Table 9 : Deck design pressure

Type of deck (2)	Location	p_0 , in kN/m ²	p_1 , in kN/m ²
Decks located below the design deck	Any location	<ul style="list-style-type: none"> • $10h_{TD}$ in general • 9 for accommodation decks 	0
Design deck	Exposed area, forward of 0,075L	15	<ul style="list-style-type: none"> • $37-d_p$ for primary supporting members • 23 for ordinary stiffeners
	Exposed area, aft of 0,075L	11	Girders and longitudinal ordinary stiffeners: <ul style="list-style-type: none"> • 14 for single deck ships • 10 for other ships Other structures: <ul style="list-style-type: none"> • 18 for single deck ships • 12 for other ships
	Unexposed area	<ul style="list-style-type: none"> • $10h_{TD}$ in general • 9 for accommodation decks 	0
Decks located above the design deck and to which side plating extends	Exposed area, forward of 0,075L	15	<ul style="list-style-type: none"> • $37-d_p$ for primary supporting members • $23-d_p$ for ordinary stiffeners
	Exposed area, aft of 0,075L	<ul style="list-style-type: none"> • 10 in general • 3 for shelter decks 	<ul style="list-style-type: none"> • $15,4(T/D_0)-d_p$ with $0,7 \leq T/D_0 \leq 0,85$ in general • 0 for higher decks
	Unexposed area	<ul style="list-style-type: none"> • $10h_{TD}$ in general • 9 for accommodation decks 	0
Decks located above the design deck and to which side plating does not extend	Exposed area, aft of 0,075L	<ul style="list-style-type: none"> • 5 in general • 3 for shelter decks 	<ul style="list-style-type: none"> • $15,4(T/D_0)-d_p$ with $0,7 \leq T/D_0 \leq 0,85$ in general • 0 for higher decks
	Unexposed area	<ul style="list-style-type: none"> • $10h_{TD}$ in general • 9 for accommodation decks 	0

Note 1:
 d_p : Vertical distance, in m, measured from the deck under consideration to the design deck (2)
 h_{TD} : 'Tweendeck height, in m
 D_0 : Vertical distance, in m, measured from the design deck to the base line.
 (1) For platforms and flats located in the machinery space, p_0+p_1 is to be not less than 25 kN/m².
 (2) Design deck: first deck above the full load waterline extending for at least 0,6L.

Table 10 : Coefficient C_1

Type of ordinary stiffener	Location	C_1
Longitudinal	Strength deck and decks below, within 0,4 L amidships	1,44
	Strength deck, forward of 0,12 L from the fore end	1,00
	Other	0,63
Transverse	Single span or end span	0,56
	Intermediate span	0,63

Table 11 : Coefficient C_2

Type of primary supporting member	Location	C_2
Longitudinal (deck girder)	Constituting longitudinal coamings of hatchways on the strength deck	7,25
	Other	4,75
Transverse (deck beam)	Constituting front beams of hatchways on the strength deck	5,60
	Other	4,75

3.8.5 Scantlings of pillars subjected to compressive axial load and bending moments

The scantlings of pillars subjected to compression axial load and bending moments are to be considered by the Society on a case-by-case basis.

3.8.6 Stringer plate thickness

The thickness of the stringer plate is to be increased by 1 mm with respect to that obtained from the formulae in [3.8.3]. In any case, it is to be not less than that of the sheer-strake.

3.8.7 Deck plating in way of masts and fishing devices

In way of masts and fishing devices, the deck thickness is to be increased by 25% with respect to that obtained from the formulae in [3.8.3].

3.8.8 Deck plating protected by wood sheathing or deck composition

The thickness of deck plating protected by wood sheathing, deck composition or other arrangements deemed suitable by the Society may be reduced by 10% with respect to that obtained from the formulae in [3.8.3]. In any case, this thickness is to be not less than 5 mm.

3.9 Tank bulkheads

3.9.1 The scantlings of plating, ordinary stiffeners and primary supporting members are to be not less than both the values obtained from the formulae in Tab 12 and the minimum values in the table.

3.10 Watertight bulkheads

3.10.1 Scantlings of plating, ordinary stiffeners and primary supporting members

The scantlings of plating, ordinary stiffeners and primary supporting members are to be not less than both the values obtained from the formulae in Tab 13 and the minimum values in the table.

3.11 Non-tight bulkheads

3.11.1 Scantlings of plating, ordinary stiffeners and primary supporting members

The scantlings of plating, ordinary stiffeners and primary supporting members are to be not less than both the values obtained from the formulae in Tab 14 and the minimum values in the table.

Table 12 : Scantlings of tank bulkheads

Element	Formula	Minimum value
Plating	Thickness, in mm: $t = 1,35s(p_l k)^{1/2}$	Minimum thickness, in mm: $t = 5,5$
Ordinary stiffeners	Section modulus, in cm ³ (1) : $w = 0,465s\ell^2 p_l k$	Minimum section modulus, in cm ³ $w = 20,0$
Primary supporting members	Section modulus, in cm ³ $w = s\ell^2 p_l k$	
(1) For ordinary stiffeners without brackets at both ends, this modulus is to be increased by 90% with respect to that obtained from this formula.		

Table 13 : Scantlings of watertight bulkheads

Element	Formula	Minimum value
Plating	Thickness, in mm (1) : $t = 3,8 s (hk)^{1/2}$	Minimum thickness, in mm: $t = 5,0$
Ordinary stiffeners	Section modulus, in cm ³ (2) : $w = 3 s \ell^2 h_b k$	Minimum section modulus, in cm ³ : $w = 10,0$
Primary supporting members	Section modulus, in cm ³ (3) : $w = 6 s \ell^2 h_b k$	
Note 1: h : Vertical distance, in m, between the lowest point of the plating and the highest point of the bulkhead. h _b : Vertical distance, in m, between the mid-span point of the ordinary stiffener and the highest point of the bulkhead. (1) For the lower strake, this thickness is to be increased by 1 mm with respect to that obtained from this formula. (2) For ordinary stiffeners without brackets at both ends, this modulus is to be increased by 90% with respect to that obtained from this formula. (3) For the collision bulkhead, this modulus is to be increased by 12,5% with respect to that obtained from this formula.		

Table 14 : Scantlings of non-tight bulkheads

Element	Formula
Plating	Minimum thickness, in mm: <ul style="list-style-type: none"> • $t = 5,0$ for bulkhead acting as pillar • $t = 4,0$ for bulkhead not acting as pillar.
Vertical ordinary stiffeners	Net section modulus, in cm^3 : <ul style="list-style-type: none"> • $w = 2,65 s \ell^2 k$ for bulkhead acting as pillar • $w = 2,00 s \ell^2 k$ for bulkhead not acting as pillar.

3.12 Connection of the fore part with the structures located aft of the collision bulkhead

3.12.1 Where the area between $0,15 L$ from the forward perpendicular and the collision bulkhead is transversely framed, side girders are to be fitted in line with those of the fore peak.

The web of such side girders is to be made of intercostal plates and the face plate is to be made of a flat bar continuous across the vertical primary supporting members and connected to them.

The thickness t of plates, in mm, and the area A of the flat bar, in cm^2 , are to be not less than the values obtained from the following formula:

$$t = 0,032 Lk^{1/2} + 6$$

without being taken less than 6,5 mm.

$$A = 0,11 Lk + 5,5$$

without being taken less than 8 cm^2 .

3.12.2 The above-mentioned side girders may be omitted provided that the thickness of the side plating in the corresponding zone of the ship is increased by 20% with respect to that obtained from the formulae in [3.7].

3.13 Fore peak longitudinally framed bottom

3.13.1 Floors

Floors are to be fitted at every four frame spaces and, in general, spaced no more than 2,5 m apart.

The floor dimensions and scantlings are to be not less than the values obtained from Tab 15.

In no case may the above scantlings be less than the values obtained from the formulae in Pt B, Ch 9, Sec 1, [2.6.2] for the corresponding side transverses.

3.13.2 Centre girder

Where no centreline bulkhead is fitted, a centre bottom girder is to be fitted having dimensions and scantlings not less than those specified in [3.13.1] for floors.

The centre bottom girder is to be connected to the collision bulkhead by means of a large end bracket.

3.13.3 Side girders

Side girders, having dimensions and scantlings not less than those specified in [3.13.1] for floors, are generally to be fitted every two longitudinals, in line with bottom longitudinals located aft of the collision bulkhead. Their extension is to be compatible in each case with the shape of the bottom.

3.14 Fore peak transversely framed bottom

3.14.1 Floors

The floor dimensions and scantlings are to be not less than those specified in Tab 15.

3.14.2 Centre girder

Where no centreline bulkhead is fitted, a centre bottom girder is to be fitted in accordance with Pt B, Ch 9, Sec 1, [2.4.3].

3.15 Fore peak longitudinally framed side

3.15.1 Side transverses

Side transverses are to extend to the upper deck and the ends of every span are to be amply faired in way of bottom and deck transverses.

The section modulus is to be not less than the value obtained, in cm^3 , from the following formula:

$$w = s \ell^2 p_e k$$

3.15.2 Horizontal rings

The platforms in Pt B, Ch 9, Sec 1, [2.9] may be replaced by equivalent structures consisting of horizontal rings (side girders, horizontal webs on the collision bulkhead and longitudinal centreline bulkhead, if any, or a substantial breast-hook on the stem) supported by struts in way of side transverses. The struts are to be firmly connected by means of vertical pillars and longitudinal primary supporting members.

Table 15 : Longitudinally framed bottoms - Floor dimensions and scantlings

Dimension or scantling	Value
Web height, in m	$h_M = 0,085 D + 0,15$
Web thickness, in mm	To be not less than the value obtained from the formulae in [3.5] for double bottom floors aft of the collision bulkhead; in any case, it need not be taken greater than 11,5 mm.
Floor flange sectional area, in cm^2	$A_p = 1,85 D$

3.16 Fore peak transversely framed side

3.16.1 Ordinary stiffeners (side frames)

Side frames fitted at every frame spacing are to have the same vertical extension as the collision bulkhead.

The section modulus is to be not less than the value obtained, in cm^3 , from the following formula:

$$w = 0,9 s \ell^2 p_E k$$

3.16.2 Side girders

Depending on the hull body shape and structure aft of the collision bulkhead, one or more adequately spaced side girders per side are to be fitted.

The section modulus of the side girder is to be not less than the value obtained in [3.7].

Moreover, the breadth b , in mm, and the thickness t , in mm, of the side girder web are generally to be not less than the values obtained from the following formulae:

$$b_A = 2,5 (180 + L)$$

$$t_A = 6,5 + 0,02 L k^{1/2}$$

3.16.3 Panting structures

In order to withstand the panting loads, horizontal structures are to be provided. These structures are to be fitted at a spacing in general not exceeding 1,2 m and consist of side girders supported by panting beams, so as to form a strengthened ring structure.

Panting beams, which generally consist of sections having the longer side vertically arranged, are to be fitted every two frames.

3.16.4 Connection between panting beams, side frames and side girders

Every panting beam is to be connected to the side transverses by means of brackets whose lengths are generally to be not less than twice the panting beam depth.

3.16.5 Connection between side frames and side girders

Side transverses not supporting panting beams are to be connected to side girders by means of brackets having the same thickness as that of the side girder and arms which are to be not less than one half of the breadth of the side girder.

3.16.6 Panting beam scantlings

The area A_B , in cm^2 , and the inertia J_B , in cm^4 , of the panting beam section are to be not less than the values obtained from the following formulae:

$$A_B = 0,55 L - 20$$

$$J_B = 0,37 (0,5 L - 18) b_B^2$$

where:

b_B : Beam length, in m, measured between the internal edges of side girders or the internal edge of the side girder and any effective central or lateral support.

Where side girder spacing is other than 2 m, the values A_B and J_B are to be modified according to the relation between the actual spacing and 2 m.

3.16.7 Panting beam of considerable length

Panting beams of considerable length are generally to be supported at the centreline by a wash bulkhead or pillars arranged both horizontally and vertically.

3.16.8 Non-tight platforms

Non-tight platforms may be fitted in lieu of side girders and panting beams. Their scantlings are to be in accordance with [3.17].

3.17 Fore peak platforms

3.17.1 General

The number and depth of non-tight platforms within the peak is to be considered by the Society on a case-by-case basis.

3.17.2 Minimum thickness of non-tight platforms

The thickness of non-tight platforms is to be not less than 4 mm.

3.17.3 Ordinary stiffeners of non-tight platforms

The section modulus of ordinary stiffeners of non-tight platforms is to be not less than the value obtained, in cm^3 , from the following formula:

$$w = 0,2 s \ell^2 k$$

3.17.4 Platform transverse primary supporting members

The sectional area of platform transverse primary supporting members, calculated considering a width of attached plating whose sectional area is equal to that of the transverse flange, is to be not less than the value obtained, in cm^2 , from the following formula:

$$A = \frac{p_E d_S b_S k}{10 C_P}$$

where:

p_E : Design pressure, acting at the ends of the platform transverse primary supporting member in the direction of its axis

d_S : Half of the longitudinal distance, in m, between the two transverse primary supporting members longitudinally adjacent to that under consideration

b_S : Half of the vertical distance, in m, between the two transverse primary supporting members vertically adjacent to that under consideration

C_P : Coefficient, to be taken equal to:

$$C_P = 1 \quad \text{for} \quad \frac{d_P}{r_P} \leq 70$$

$$C_P = 1,7 - 0,01 \frac{d_P}{r_P} \quad \text{for} \quad 70 < \frac{d_P}{r_P} \leq 140$$

When $d_P / r_P > 140$, the scantlings of the transverse primary supporting member are to be considered by the Society on a case-by-case basis.

d_P : Distance, in cm, from the face plate of the side transverse and that of the bulkhead vertical web, connected by the platform transverse pri-

- primary supporting member, measured at the level of the transverse primary supporting member
- r_p : Radius of gyration of the transverse primary supporting member, to be obtained, in cm, from the following formula:
- $$r_p = \sqrt{\frac{J}{A_E}}$$
- J : Minimum moment of inertia, in cm⁴, of the transverse primary supporting member considered
- A_E : Actual sectional area, in cm², of the transverse section of the transverse primary supporting member considered.

3.18 Bulbous bow

3.18.1 General

Where a bulbous bow is fitted, fore peak structures are to effectively support the bulb and are to be adequately connected to its structures.

3.18.2 Plating

The thickness of the shell plating of the fore end of the bulb and the first strake above the keel is generally to be not less than that required in [3.20.2] for plate stems. This thickness is to be extended to the bulbous zone.

3.18.3 Connection with the fore peak

Fore peak structures are to be extended inside the bulb as far as its size and shape permit.

3.18.4 Longitudinal stiffeners

Bottom and side longitudinals are to extend inside the bulb, forward of the fore perpendicular, by at least 30% of the bulb length measured from the perpendicular to the fore end of the bulb.

The fore end of longitudinals is to be located in way of a reinforced transverse ring; forward of such ring, longitudinals are to be replaced by ordinary transverse rings.

3.18.5 Floors

Solid floors are to be part of reinforced transverse rings generally spaced not more than 3 frame spaces apart.

3.18.6 Breasthooks

Breasthooks, to be placed in line with longitudinals, are to be extended on the sides aft of the stem, so as to form longitudinal side girders.

3.19 Reinforcement of the flat bottom forward area

3.19.1 Area to be reinforced

The flat bottom forward area is located over the bottom between 0,25 L aft of the fore end and the collision bulkhead.

The reinforcement of the bottom forward area is to be considered if:

$$T_F < 0,03 L$$

where T_F is the minimum forward draught, in m, among those foreseen in operation for all the loading conditions.

3.19.2 Arrangement of longitudinally framed bottom

Solid floors are to be fitted at every two frame spaces.

Adequately spaced side girders are to be fitted or, as an alternative, ordinary stiffeners having increased scantlings may be fitted.

3.19.3 Arrangement of transversely framed bottom

Solid floors are to be fitted at every frame spacing.

Side girders with a depth equal to that of the floors are to be fitted.

3.19.4 Plating

The thickness of the flat bottom forward area plating is to be not less than the value obtained, in mm, from the following formula:

$$t = 0,1 Lk^{1/2} + 10 s$$

3.19.5 Ordinary stiffeners and primary supporting members

For a longitudinally framed bottom, the scantlings of ordinary stiffeners and primary supporting members are to be not less than those obtained from [3.2], where the span length ℓ of ordinary stiffeners is to be taken not less than 1,8 m.

For a transversely framed bottom, the scantlings of ordinary stiffeners and primary supporting members are to be not less than those obtained from [3.3].

3.20 Stems

3.20.1 Arrangements

Adequate continuity of strength is to be ensured at the connection of stems to the surrounding structure.

Abrupt changes in sections are to be avoided.

3.20.2 Plate stems

The plating forming the stems is to be supported by horizontal diaphragms spaced not more than 1200 mm apart and connected, as far as practicable, to the adjacent frames and side girders.

If considered necessary, and particularly where the stem radius is large, a centreline stiffener or web of suitable scantlings is to be fitted.

The thickness of the plates below the load waterline is to be not less than the value obtained, in mm, from the following formula:

$$t = 1,37 (0,95 + L^{1/2})k^{1/2}$$

Above the load waterline this thickness may be gradually tapered towards the stem head, where it is to be not less than that required for side plating at ends.

3.20.3 Bar stems

The area of bar stems constructed of forged or rolled steel is to be not less than the value obtained, in cm², from the following formula:

$$A = \left(0,40 + \frac{10T}{L}\right)(0,009L^2 + 20)k$$

where the ratio T/L in the above formulae is to be taken neither less than 0,05 nor more than 0,075.

The cross-sectional area of the stem may be gradually tapered from the load waterline to the upper end, where it may be equal to two thirds of the value as calculated above.

The thickness of the bar stem is to be not less than the value obtained, in mm, from the following formula:

$$t = 0,4 Lk^{1/2} + 13$$

The lower part of the stem may be constructed of cast steel; where necessary, a vertical web is to be fitted for welding of the centre keelson.

Welding of the bar stem with the bar keel and the shell plating is to be in accordance with Pt B, Ch 12, Sec 1, [3.4].

3.21 Sternframes

3.21.1 Application

These requirements apply to sternframes of single screw ships.

Sternframes of twin screw ships are to be considered by the Society on a case-by-case basis.

3.21.2 General

Sternframes may be constructed of cast or forged steel, with a hollow section, or fabricated from plates.

Cast steel and fabricated sternframes are to be strengthened by adequately spaced horizontal plates.

In castings, abrupt changes of section are to be avoided; all sections are to have adequate tapering radius.

3.21.3 Connections with the hull structure

Sternframes are to be effectively attached to the aft structure and the lower part of the sternframe is to be extended forward of the propeller post to a length not less than $1500 + 6L$ mm, in order to provide an effective connection with the keel. However, the sternframe need not extend beyond the after peak bulkhead.

The thickness of bottom plating connected with the sternframe is to be not less than that obtained, in mm, from the following formula:

$$t = 0,05 Lk^{1/2} + 7$$

3.21.4 Connection with the keel

The thickness of the lower part of the sternframes is to be gradually tapered to that of the solid bar keel or keel plate.

Where a keel plate is fitted, the lower part of the sternframe is to be so designed as to ensure an effective connection with the keel.

3.21.5 Connection with centre keelson

Where the sternframe is made of cast steel, the lower part of the sternframe is to be fitted, as far as practicable, with a longitudinal web for connection with the centre keelson.

3.21.6 Scantlings of propeller posts

The scantlings of propeller posts are to be not less than the values obtained from the formulae in Tab 16.

Scantlings and proportions of the propeller post which differ from those above may be considered acceptable provided that the section modulus of the propeller post section about its longitudinal axis is not less than that calculated with the propeller post scantlings in Tab 16.

Table 16 : Single screw ships - Scantlings of propeller posts

	Fabricated propeller post	Cast propeller post	Bar propeller post, cast or forged, having rectangular section
Gross scantlings of propeller posts			
a, in mm	$50 L^{1/2}$	$33 L^{1/2}$	$10 \cdot \sqrt{2,5(L+10)}$
b, in mm	$35 L^{1/2}$	$23 L^{1/2}$	$10 \cdot \sqrt{1,6(L+10)}$
t ₁ , in mm	$2,5 L^{1/2}$	$3,2 L^{1/2}$	φ
t ₂ , in mm	φ	$4,4 L^{1/2}$	φ
t _D , in mm	$1,3 L^{1/2}$	$2,0 L^{1/2}$	φ
R, in mm	φ	$50 L^{1/2}$	φ
Note 1: φ = not applicable.			

3.21.7 Propeller shaft bossing

In single screw ships, the thickness of the propeller shaft bossing, included in the propeller post, is to be not less than 60% of that required in Pt B, Ch 9, Sec 2, [6.3.2] for bar propeller posts with a rectangular section.

3.22 Machinery casings

3.22.1 Engine room skylight coamings

If the engine room skylights are fitted with opening-type covers providing light and air, the height of coamings is to be not less than:

- 900 mm, for skylights located on working decks
- 300 mm, for skylights located on superstructure decks.

3.22.2 Casing plating

The plating thickness of unprotected casing bulkheads is to be not less than the value obtained from the formulae in [3.23]. In any case, the plating thickness of protected or unprotected casing bulkheads is to be not less than 5 mm.

3.22.3 Casing vertical ordinary stiffeners

The section modulus of vertical ordinary stiffeners is to be not less than the value obtained, in cm^3 , from the following formula:

$$w = 2,6 s \ell^2 k$$

In addition to the above, the section modulus of vertical ordinary stiffeners of casings acting as pillars is to be not less than the value obtained from the formulae in [3.8], where the width, in mm, of the attached plating is to be less than 50 times the attached plating thickness.

3.22.4 Scantlings of engine room skylight coamings

The thickness of engine room skylight coamings is to be not less than 6 mm.

Where the height of engine room skylight coamings is greater than 900 mm, the section modulus of vertical ordinary stiffeners with spacing not greater than 760 mm is to be increased by 10% with respect to that obtained from the formula in [3.23] for vertical ordinary stiffeners of deckhouses.

3.23 Superstructures and deckhouses

3.23.1 Load point

Lateral pressure is to be calculated at:

- mid-height of the bulkhead, for plating
- mid-span, for stiffeners.

3.23.2 Design pressure

The design pressure to be used for the determination of scantlings of the structure of front, side and aft bulkheads of superstructures and deckhouses is to be obtained, in kN/m^2 , from the following formula:

$$p = 10 a c [b f - (z - T)]$$

without being less than p_{\min} ,

where:

a : Coefficient defined in Tab 17

Table 17 : Lateral pressure for superstructures and deckhouses - Coefficient a

Type of bulkhead	Location	a
Unprotected front	Lowest half	$2 + \frac{L}{120}$
	Second half	$1 + \frac{L}{120}$
Aft end	Any location, when $x/L \leq 0,5$	$0,7 + \frac{L}{1000} - 0,8 \frac{x}{L}$
	Any location, when $x/L > 0,5$	$0,5 + \frac{L}{1000} - 0,4 \frac{x}{L}$
Other	Any location	$0,5 + 0,0067 L$

c : Coefficient taken equal to:

$$c = 0,3 + 0,7 \frac{b_1}{B_1}$$

For exposed parts of machinery casings, c is to be taken equal to 1

b_1 : Breadth of deckhouse, in m, at the position considered, to be taken not less than $0,25 B_1$

B_1 : Actual maximum breadth of ship on the exposed weather deck, in m, at the position considered

b : Coefficient defined in Tab 18

Table 18 : Lateral pressure for superstructures and deckhouses - Coefficient b

Location of bulkhead (1)	b
$\frac{x}{L} \leq 0,45$	$1 + \left(\frac{\frac{x}{L} - 0,45}{C_B + 0,2} \right)^2$
$\frac{x}{L} > 0,45$	$1 + 1,5 \left(\frac{\frac{x}{L} - 0,45}{C_B + 0,2} \right)^2$
Note 1:	
C_B : Block coefficient, with $0,6 \leq C_B \leq 0,8$	
(1) For deckhouse sides, the deckhouse is to be subdivided into parts of approximately equal length, not exceeding $0,15L$ each, and x is to be taken as the co-ordinate of the centre of each part considered.	

f : Coefficient equal to:

$$f = \frac{L}{10} e^{-L/300} - \left[1 - \left(\frac{L}{150} \right)^2 \right]$$

p_{\min} : Minimum lateral pressure defined in Tab 19.

3.23.3 Plating

The plating thickness is to be not less than the value obtained from Tab 20.

3.23.4 Deck ordinary stiffeners

The section modulus of ordinary stiffeners is to be not less than the value obtained from the formulae in [3.8].

Table 19 : Lateral minimum pressure for superstructures and deckhouses

Type of bulk-head	Location	p_{min} , in kN/m ²
Unprotected front	Lowest tier	30
	Second and third tiers	15
Protected front, side and aft end	Lowest, second and third tiers	15

3.23.5 Bulkhead vertical ordinary stiffeners

The section modulus of bulkhead ordinary stiffeners, connected at their ends by lugs or directly welded to the decks, is to be not less than the value obtained, in cm³, from the following formula:

$$w = 0,35 s \ell^2 p k$$

where:

p : Design pressure, in kN/m², defined in Pt B, Ch 9, Sec 4, [2.2.2]

ℓ : Span, in m, of primary supporting members, to be taken not less than 2 m.

The scantlings of ordinary stiffeners connected at their ends other than as above are to be considered by the Society on a case-by-case basis.

3.23.6 Vertical ordinary stiffeners (frames) of complete or partial superstructures

The section modulus of vertical ordinary stiffeners of complete or partial superstructures is to be not less than both the

value obtained from the formulae in [3.7] for 'tweendeck ordinary stiffeners and the value obtained from the formula in [3.23.5].

3.24 Hatch covers**3.24.1 Height of hatch coamings**

The height above the deck of hatch coamings closed by portable covers is to be not less than:

- 600 mm, for hatch covers located on exposed areas of the working deck
- 300 mm, for hatch covers located on exposed areas of the lowest tier of superstructures.

3.24.2 Height of hatch coamings on exposed decks of ships having L < 18 m and navigation notation "coastal area" (1/7/2006)

The height above the deck of hatch coamings closed by portable covers, located on exposed areas of ships having L < 18 m and navigation notation **coastal area**, is to be not less than:

- 400 mm, for hatch covers located on the working deck
- 150 mm, for hatch covers located on the lower tier of superstructures.

3.24.3 Hatch coaming thickness

The thickness of hatch coaming plating is to be not less than the value obtained from the formulae in [3.8] for the ship's deck.

Table 20 : Plating thickness

Plating	Location	Thickness, in mm (1) (2)	Minimum thickness, in mm
Front bulkheads	Lowest tier	$3 s (pk)^{1/2}$	$6k^{1/2}$
	Second tier and above	$3 s (pk)^{1/2}$	$5k^{1/2}$
Side and aft bulkheads	All tiers	$3 s (pk)^{1/2}$	$5k^{1/2}$
Unprotected deck of deckhouses	Lowest tier	$3,3 s + 0,0085 Lk^{1/2} + 3,2$	$6k^{1/2}$
	Second tier	$3,0 s + 0,0077 Lk^{1/2} + 2,9$	$5k^{1/2}$
	Third tier and above	$2,8 s + 0,0072 Lk^{1/2} + 2,7$	$5k^{1/2}$
Unprotected deck of bridge and forecastle	Lowest tier	$c_1 (5 s + 0,013 Lk^{1/2} + 2,5)$	$6k^{1/2}$
	Second tier	$0,9 c_1 (5 s + 0,013 Lk^{1/2} + 2,5)$	$5k^{1/2}$
	Third tier and above	$0,85 c_1 (5 s + 0,013 Lk^{1/2} + 2,5)$	$5k^{1/2}$
Unprotected deck of poop	Lowest tier	$c_1 (4,5 s + 0,01 Lk^{1/2} + 2,5)$	$6k^{1/2}$
	Second tier	$0,9 c_1 (4,5 s + 0,01 Lk^{1/2} + 2,5)$	$5k^{1/2}$
	Third tier and above	$0,85 c_1 (4,5 s + 0,01 Lk^{1/2} + 2,5)$	$4k^{1/2}$

Note 1:

c_1 : Coefficient, to be taken equal to:

- $c_1 = 0,9$ for $T / D < 0,7$
- $c_1 = 1 - (0,56 - 0,66 (T / D))$ for $0,7 \leq T / D < 0,85$
- $c_1 = 1$ for $T / D \geq 0,85$

p : Design pressure, in kN/m², defined in [3.23.2].

(1) For decks of superstructures and deckhouses protected by other superstructures or deckhouses housing accommodation or service spaces, the thickness may be reduced by 10% with respect to that obtained from this formula.

(2) For decks sheathed with wood, the thickness may be reduced by 10% with respect to that obtained from this formula.

3.25 Aft ramp

3.25.1 Minimum net thickness of the aft ramp and the lower part of the aft ramp side

The net thickness of plating of the aft ramp and the lower part of the aft ramp side is to be not less than 11 mm.

3.25.2 Plating of the aft ramp and the lower part of the aft ramp side

The net thickness of plating of the aft ramp and the lower part of the aft ramp side is to be increased by 2 mm with respect to that calculated according to [3.7] for side plating with the same plate panel dimensions.

3.25.3 Plating of the upper part of the aft ramp side

The net thickness of plating of the upper part of the aft ramp side is to be not less than the value calculated according to [3.7] for side plating with the same plate panel dimensions.

3.26 Arrangement for hull and superstructure openings

3.26.1 Sidescuttles

Sidescuttles may not be fitted in such a position that their sills are below a line drawn parallel to the sheer at side and having its lowest point 0,5 m above the summer load waterline.

No sidescuttles may be fitted in any spaces which are appropriated exclusively for the carriage of cargo.

3.26.2 Freeing ports

The freeing port area in bulwarks is to be not less than the value obtained from the formulae in Pt B, Ch 9, Sec 9, [5].

For ships with $L < 24$ m and navigation notation **coastal area**, the freeing port area in bulwarks on each side of the ship may be not less than the value obtained from the following formula:

$$A = 0,035 \ell_B + A_C$$

where:

ℓ_B : Length, in m, of bulwark in the well, to be taken not greater than 0,7 L

A_C : Area, in m², to be taken, with its sign, equal to:

$$A_C = 0,04 \ell_B (h_B - 1,2) \quad \text{for } h_B > 1,2$$

$$A_C = 0 \quad \text{for } 0,9 \leq h_B \leq 1,2$$

$$A_C = 0,04 \ell_B (h_B - 0,9) \quad \text{for } h_B < 0,9$$

h_B : Mean height, in m, of bulwark in the well of length ℓ_B .

3.26.3 Openings in bulkheads of enclosed superstructures and other outer structures

All access openings in bulkheads of enclosed superstructures and other outer structures (e.g. machinery casings) through which water can enter and endanger the ship are to be fitted with doors of steel or other equivalent material, permanently and strongly attached to the bulkhead, and framed, stiffened and fitted so that the whole structure is of equivalent strength to the unpierced bulkhead and weathertight when closed. The doors are to be capable of being operated from both sides and generally to open outwards to give additional protection against wave impact.

These doors are to be fitted with gaskets and clamping devices or other equivalent means permanently attached to the bulkhead or to the door themselves.

Other openings are to be fitted with equivalent covers, permanently attached in their proper position.

3.26.4 Door sills (1/7/2006)

a) The height of the sill of the doors is to be not less than:

- 600 mm above the working deck
- 300 mm above the deck of the lower tier of superstructures.

For doors protected from the direct impact of waves, except for those giving direct access to machinery spaces, the height of the sill may be taken not less than:

- 380 mm above the working deck
- 150 mm above the deck of the lower tier of superstructures.

b) For vessels less than 24 m in length, depending on their navigation notation and the relevant position on the exposed deck, the Society may accept reduced height door sills in respect of the values given above.

3.26.5 Ventilator coamings

The height of ventilator coamings is to be not less than the value obtained from Tab 21.

The thickness of ventilator coaming plating is to be not less than both the value obtained from the formulae in [3.8] for the ship's deck and the value obtained from the formulae in [3.23] for a deckhouse in the same position as the ventilator.

Ventilator coamings are to be provided with weathertight closing appliances to be used in rough weather. These appliances may be omitted when the ventilator height is greater than the minimum value specified in Tab 21.

Table 21 : Ventilator coamings

Ship's length, in m	Coaming height (1), in mm		Minimum height of ventilators, in m	
	Ventilators openings on working decks	Ventilators openings on decks of lower tier of superstructure	Ventilators openings on working decks	Ventilators openings on decks of lower tier of superstructure
L > 45	900	760	4,5	2,3
24 ≤ L ≤ 45	760	450	3,4	1,7
12 ≤ L < 24	760	450	2,5	1,0
L < 12	300	300	2,5	1,0

(1) When necessary, the coaming height is to be adequately increased in the machinery space, in order to avoid free entry of sea water.

4 Scantlings of masts and fishing devices (e.g. gantries and trawl gal-lows)

4.1 Design loads

4.1.1 The design loads to be considered for the strength check of masts and fishing devices are:

- the weights of booms and net hauling fittings
- the cargo loads, to be taken equal to the maximum break loads of the winches.

4.1.2 Adequate safety factors are to be used when designing supporting structure for fishing gear, taking into account operational conditions and wave effects.

4.2 Strength check

4.2.1 Calculation of stresses in the structural elements

The stresses in the structural elements of masts and fishing devices are to be obtained by means of direct calculations, using the design loads specified in [4.1].

4.2.2 Yielding check

The von Mises equivalent stresses in the structural elements of masts and fishing devices are to comply with the following formula:

$$\sigma_E \leq 0,5R_{eH}$$

where:

σ_E : Von Mises equivalent stress, in N/mm², to be obtained as a result of direct calculations

R_{eH} : Minimum yield stress, in N/mm², of the material, defined in Pt B, Ch 4, Sec 1, [2].

4.2.3 Buckling check

The buckling strength of the structural elements of masts and fishing devices is to be checked in compliance with Part B, Chapter 7 or Part B, Chapter 8, as applicable.

5 Hull outfitting

5.1 Rudder stock scantlings

5.1.1 The rudder stock diameter is to be increased by 5% with respect to that obtained from the formula in Pt B, Ch 10, Sec 1, [4].

5.2 Propeller shaft brackets

5.2.1 General

Propeller shafting is either enclosed in bossing or independent of the main hull and supported by shaft brackets.

5.2.2 Double arm propeller shaft brackets

The scantlings of double arm propeller shaft brackets are to be obtained from the formulae in Pt B, Ch 10, Sec 3, [1.2].

5.2.3 Single arm propeller shaft brackets

For ships less than 30 m in length, single arm propeller shaft brackets may be fitted. Their scantling are to be considered by the Society on a case-by-case basis.

5.3 Equipment

5.3.1 General

Fishing vessels are to be provided with equipment in anchors, chain cables and ropes to be obtained from Tab 22, based on their Equipment Number EN, to be calculated according to Pt B, Ch 10, Sec 4, [2].

The equipment in anchors, chain cables and ropes of fishing vessels with the navigation notation **coastal area** may be obtained from Tab 22 based on the Equipment Number EN corresponding to the row above that relevant to the Equipment Number calculated for the ship considered.

In general, stockless anchors are to be adopted.

For ships with EN greater than 720, the determination of the equipment is to be considered by the Society on a case-by-case basis.

5.3.2 Anchors

The required mass for each anchor is to be obtained from Tab 22.

The individual mass of a main anchor may differ by ±7% from the mass required for each anchor, provided that the

total mass of anchors is not less than the total mass required in Tab 22.

The mass of the head of an ordinary stockless anchor, including pins and accessories, is to be not less than 60% of the total mass of the anchor.

Where a stock anchor is provided, the mass of the anchor, excluding the stock, is to be not less than 80% of the mass required in Tab 22 for a stockless anchor. The mass of the stock is to be not less than 25% of the mass of the anchor without the stock but including the connecting shackle.

5.3.3 Scantlings of stud link chain cables

The mass and geometry of stud link chain cables, including the links, are to be in compliance with the requirements in Pt D, Ch 4, Sec 1, [2].

The diameter of stud link chain cables is to be not less than the value in Tab 22.

5.3.4 Chain cable arrangement

Chain cables are to be made by lengths of 27,5 m each, joined together by Dee or lugless shackles.

The total length of chain cables, as required in Tab 22, is to be divided into approximately equal parts between the two anchors ready for use.

Where different arrangements are provided, they are to be considered by the Society on a case-by-case basis.

5.3.5 Wire ropes (1/7/2018)

As an alternative to the stud link chain cables mentioned, wire ropes may be used for both the anchors, for ship's length less than 40 m.

The wire ropes above are to have a total length equal to 1,5 times the corresponding required length of stud link chain cables, obtained from Tab 22, and a minimum breaking load equal to that given for the corresponding stud link chain cable (see [5.3.3]).

A short length of chain cable is to be fitted between the wire rope and the anchor, having a length equal to 12,5 m or the

distance from the anchor in the stowed position to the winch, whichever is the lesser.

All surfaces being in contact with the wire are to be rounded with a radius of not less than 10 times the wire rope diameter (including stem).

When chain cables are replaced by trawl warps, the anchor is to be positioned on the forecastle deck so that it may be readily cast after it has been shackled to the trawl warp. Chocks or rollers are to be fitted at suitable locations, along the path of the trawl warps, between the winch and the mooring chocks.

6 Protection of hull metallic structures

6.1 Protection of deck by wood sheathing

6.1.1

Before fitting the wood sheathing, deck plating is to be protected with suitable protective coating.

The thickness of wood sheathing of decks is to be not less than:

- 65 mm, if made of pine
- 50 mm, if made of hardwood, such as teak.

The width of planks may not exceed twice their thickness.

6.2 Protection of cargo sides by battens

6.2.1 In cargo spaces, where thermal insulation is fitted, battens formed by spaced planks are generally to be fitted longitudinally.

6.3 Deck composition

6.3.1 The deck composition is to be of such a material as to prevent corrosion and is to be effectively secured to the steel structures underneath by means of suitable connections.

Table 22 : Equipment (1/1/2022)

Equipment number EN A < EN ≤ B		Stockless anchors		Stud link chain cables for anchors			Mooring lines		
A	B	N	Mass per anchor, in kg	Total length, in m	Diameter, in mm		N	Length of each line, in m	Ship Design Minimum Breaking load, in kN
					mild steel	high strength steel			
30	40	2	80	165	11		2	50	29
40	50	2	100	192,5	11		2	60	29
50	60	2	120	192,5	12,5		2	60	29
60	70	2	140	192,5	12,5		2	80	29
70	80	2	160	220	14	12,5	2	100	34
80	90	2	180	220	14	12,5	2	100	37
90	100	2	210	220	16	14	2	110	37
100	110	2	240	220	16	14	2	110	39
110	120	2	270	247,5	17,5	16	2	110	39
120	130	2	300	247,5	17,5	16	2	110	44
130	140	2	340	275	19	17,5	2	120	44
140	150	2	390	275	19	17,5	2	120	49
150	175	2	480	275	22	19	2	120	54
175	205	2	570	302,5	24	20,5	2	120	59
205	240	2	660	302,5	26	22	2	120	64
240	280	2	780	330	28	24	3	120	71
280	320	2	900	357,5	30	26	3	140	78
320	360	2	1020	357,5	32	28	3	140	86
360	400	2	1140	385	34	30	3	140	93
400	450	2	1290	385	36	32	3	140	101
450	500	2	1440	412,5	38	34	3	140	108
500	550	2	1590	412,5	40	34	4	160	113
550	600	2	1740	440	42	36	4	160	118
600	660	2	1920	440	44	38	4	160	123
660	720	2	2100	440	46	40	4	160	127

SECTION 4

MACHINERY

1 General

1.1 Application

1.1.1 Machinery systems fitted on board ships having the notation **fishing vessel** are to comply with the relevant sections of Part C, Chapter 1, with the exception of the following systems:

- bilge system
- scuppers and sanitary discharges
- air pipes and sounding devices
- refrigerating installations,

for which substitutive requirements are provided in this Section.

1.1.2 This Section does not cover the design and performances of the fishing equipment. However, the piping systems and pressure vessels serving the fishing equipment are required to comply with the relevant Sections of Part C.

1.2 Documents to be submitted

1.2.1 In addition to the documents listed in Part C, Chapter 1, the diagram of the piping systems (hydraulic system, etc.) serving the fishing equipment is to be submitted for approval.

2 Bilge system

2.1 General

2.1.1 Application

The following provisions supersede those given in Pt C, Ch 1, Sec 10, [6].

2.1.2 Principle

- a) Fishing vessels are to be provided with an efficient bilge pumping system capable of pumping from and draining, under all practical conditions, any watertight compartment other than spaces exclusively intended for the carriage of fresh water, water ballast or fuel oil, for which other efficient means of pumping are to be provided.
- b) In fishing vessels where fishing handling or processing may cause quantities of water to accumulate in enclosed spaces, adequate drainage is to be provided.
- c) The bilge pumping system is to consist of pumps connected to a bilge main line so arranged as to allow the draining of all spaces mentioned in a).
- d) Bilge pumping arrangement may be dispensed with in particular compartments provided the safety of the ship is not impaired.

- e) Where expressly permitted, some small compartments may be drained by means of hand pumps.
- f) Bilge and ballast systems are to be so designed as to prevent the possibility of water passing from the sea and from water ballast spaces into the cargo and machinery spaces, or from one compartment to another. Provisions are to be made to prevent any space having bilge and ballast connections being inadvertently flooded from the sea when containing cargo, or being discharged through the bilge system when containing water ballast.

2.2 Design of the bilge system

2.2.1 General

- a) All suction pipes up to the connection with the bilge pumps are to be independent from any other piping system of the ship.
- b) Non-return valves are to be fitted on:
 - the pipe connections to bilge distribution boxes
 - the suction of pumps also having connections from the sea or from compartments normally intended to contain liquid
 - the direct suction connected to independent bilge pumps, where required.
- c) All compartments are to be provided with at least one suction on each side. However, in the case of short and narrow compartments, a single suction ensuring an efficient draining may be accepted.

2.2.2 Draining of machinery spaces

- a) Machinery spaces of ships with double bottom, or where the rise of floor is less than 5°, are to be provided on each side with one bilge suction connected to the bilge main.
- b) Machinery spaces of ships without double bottom, or where the rise of floor is equal to or exceeds 5°, may be provided with only one bilge suction located in the centreline and connected to the bilge main.
- c) In addition to the bilge suction required in a) and b), machinery spaces of ships of 24 m length or more are to be provided with a direct suction, which is to be led direct to an independent power bilge pump and so arranged that it can be used independently of the bilge main.

2.2.3 Draining of holds

- a) Holds of ships with double bottom, or where the rise of floor is less than 5°, are to be provided on each side with one bilge suction connected to the bilge main.
- b) Holds of ships without double bottom, or where the rise of floor is equal to or exceeds 5°, may be provided with only one bilge suction located in the centreline and connected to the bilge main.

2.2.4 Draining of refrigerated spaces

Refrigerated spaces are to be provided with drainage arrangement allowing the continuous drainage of condensates.

2.2.5 Draining of fore and aft peaks

- Fore and aft peaks, where not used as tanks, are to be fitted with a bilge suction connected to the bilge main. Passage through the collision bulkhead is to comply with Pt C, Ch 1, Sec 10, [5.3.3].
- Peaks of small dimensions may be drained by means of a hand pump provided that the suction lift is well within the capacity of the pump and in no case exceeds 7,30 m.

2.2.6 Draining of double bottom compartments

Double bottom compartments, where not used as tanks, are to be provided with bilge suctions. Their number and location are to comply with the provisions of [2.2.3]. However, if deemed acceptable by the Society, the cofferdams fitted between two different compartments of the double bottom may be provided with one bilge suction only.

2.2.7 Draining of other compartments

- Provision is to be made for the drainage of chain lockers and other fore spaces by means of hand or power pump suctions or hydraulic ejectors.
- Provision is to be made for the drainage of the steering gear compartment and other spaces located above the aft peak by means of suctions connected to the bilge main or by means of hand pumps or hydraulic ejectors. These spaces may, however, be drained by means of scuppers discharging to the shaft tunnel, provided that the discharge pipes are fitted with self-closing valves situated in easily visible and accessible positions.

2.3 Bilge pumps

2.3.1 Number and arrangement of pumps

- Fishing vessels are to be provided with at least two power bilge pumps of the self-priming type connected to the bilge main and having the capacity required in [2.3.4]. One of these pumps may be driven by the propulsion machinery.
- Each bilge pump may be replaced by two or more pumps, provided that they are connected to the bilge main and that their total capacity is not less than that required in [2.3.4].
- One of the bilge pumps required in a) may be replaced by a hydraulic ejector having the capacity required in [2.3.4] and connected to a high pressure water pump.
- For ships of less than 24 m in length and having the navigation notation **coastal area**, one of the bilge pumps required in a) may be replaced by hand pumps, to the satisfaction of the Society.
- Where permitted, hand pumps are to be operable from an easily accessible position above the load waterline.

2.3.2 Location of bilge pumps

Bilge pumps are to be located on the aft side of the collision bulkhead. This may not apply to those pumps only used for

the draining of the spaces located on the fore side of the collision bulkhead.

2.3.3 Use of pumps intended for other duties

- Pumps used for sanitary service, general service or ballast may be considered as independent bilge pumps provided that:
 - they have the capacity required in [2.3.4]
 - they are of the self-priming type
 - they are connected to the bilge system.
- Non-return valves are to be provided in accordance with [2.2.1], item b).

2.3.4 Bilge pump capacity (1/1/2001)

- The capacity Q of each bilge pump is to be not less than the value given by:

$$Q = 0,00565d^2$$

where:

Q : Minimum capacity of each pump, in m³/h

d : Internal diameter of the bilge main as defined in [2.4.1].

- If the capacity of one of the pumps is less than the rule capacity, the deficiency may be compensated by an excess capacity of the other pumps. Such deficiency is, however, not to exceed 30% of the rule capacity.

2.4 Size of bilge pipes

2.4.1 Bilge main line

- The diameter of the bilge main is to be calculated according to the following formulae:

- for ships of 24 m in length or more:

$$d = 25 + 1,68\sqrt{L(B+D)}$$

and

$$d \geq 60$$

- for ships of less than 24 m in length:

$$d = 25 + 0,85L$$

where:

d : Internal diameter of the bilge main, in mm

L : Length of the ship between perpendiculars, in m

B : Breadth of the ship, in m

D : Depth of the ship, measured up to the bulkhead deck, in m

- The actual diameter is in no case to be more than 5 mm smaller than that obtained from the formulae given in a).

2.4.2 Branch bilge suction pipes

- The diameter of the pipes situated between the distribution boxes and the suctions in the various spaces (holds, machinery space, etc) is to be calculated according to the following formulae:

- for ships of 24 m in length or more:

$$d_1 = 25 + 2,16\sqrt{L_1(B+D)}$$

and

$$d_1 \geq 50$$

- for ships of less than 24 m in length:

$$d_1 = 25 + 2,16\sqrt{L_1(B+D)}$$

or

$$d_1 = 25 + 0,85L$$

whichever is the lesser

where:

d_1 : Internal diameter of the suction pipe, in mm

L_1 : Length of the space considered, in m

L, B, D : Length, breadth and depth of the ship as defined in [2.4.1]

- b) The actual diameter is in no case to be more than 5 mm smaller than that obtained from the formulae given in a).

2.5 Bilge piping arrangement

2.5.1 Passage through double bottom compartments and tanks

Bilge pipes are not to pass through double bottom compartments or tanks unless they are enclosed in appropriate pipe tunnels. Where this is not practicable, pipes are to be of reinforced thickness as per Pt C, Ch 1, Sec 10, Tab 5 and made of either one piece or several pieces assembled by welding or by reinforced flanges.

2.5.2 Bilge suction in machinery spaces and shaft tunnels

In machinery spaces and shaft tunnels, the termination pipes of the bilge suction are to be straight and vertical and are to be led to mud boxes so arranged as to be easily inspected and cleaned. The lower end of the termination pipe is not to be fitted with a strum box.

2.5.3 Bilge suction in other compartments

In compartments other than machinery spaces and shaft tunnels, the open ends of bilge suction pipes are to be fitted with strum boxes or strainers having holes not more than 10 mm in diameter. The total area of such holes is not to be less than twice the required cross-section of the suction pipe.

3 Scuppers and sanitary discharges

3.1 General

3.1.1 Discharges led through the shell either from spaces below the working deck or from within enclosed superstructures or deckhouses on the working deck fitted with weathertight doors are to be fitted with accessible means for preventing water from passing inboard.

3.1.2 Each separate discharge is to have an automatic non-return valve with a positive means of closing it from an accessible position, except when:

- satisfactory analysis is submitted to the Society, demonstrating that the entry of water into the vessel through the opening is not likely to lead to dangerous flooding, and
- the piping is of reinforced thickness as per Pt C, Ch 1, Sec 10, Tab 5.

3.1.3 The means for operating the positive action valve is to be provided with an indicator showing whether the valve is open or closed.

3.2 Discharges through manned machinery spaces

3.2.1 In manned machinery spaces, main and auxiliary discharges essential for the operation of machinery may be controlled locally. The controls are to be accessible and are to be provided with indicators showing whether the valves are open or closed.

3.3 Materials

3.3.1 Fittings attached to the shell and the valves required in [3.1.2] are to be of steel, bronze or other ductile material.

3.3.2 (1/7/2002)

All pipes between the shell and the valves are to be of steel.

4 Air pipes and sounding devices

4.1 Air pipes

4.1.1 General

Air pipes are to be fitted to all spaces which are not fitted with alternative ventilation arrangements.

4.1.2 Exposed parts of air pipes

Where air pipes to tanks and void spaces below deck extend above the working or the superstructure decks, the exposed parts of the pipes are to be of strength equivalent to the adjacent structures and fitted with the appropriate protection.

4.1.3 Means of closing

Openings of air pipes are to be provided with means of closing, permanently attached to the pipe or adjacent structure.

4.1.4 Height of air pipes (1/7/2006)

The height of air pipes above deck to the point where water may have access below is to be at least:

- 760 mm on the working deck, and
- 450 mm on the superstructure deck.

The Society may accept reduction of the height of an air pipe to avoid interference with the fishing operations.

In any case, for ships less than 24 m and with navigation notation "coastal area", air pipes fitted at a height above the working deck of 450 mm may be accepted.

4.2 Sounding devices

4.2.1 General

Sounding devices are to be fitted:

- to the bilges of those compartments which are not readily accessible at all times during voyages, and
- to all tanks and cofferdams.

4.2.2 Termination of sounding pipes

Where sounding pipes are fitted, their upper ends are to extend to a readily accessible position and, where practicable, above the working deck.

4.2.3 Means of closing

The openings of the sounding pipes are to be provided with permanently attached means of closing. Sounding pipes which are not extended above the working deck are to be fitted with automatic self-closing devices.

4.2.4 Special arrangements for sounding pipes of flammable oil tanks

Where tanks containing fuel oil or flammable oil are fitted with sounding pipes, their upper ends are to terminate in safe positions and are to be fitted with suitable means of closure. Gauges made of glass of substantial thickness and protected with a metal case may be used, provided that automatic closing valves are fitted. Other means of ascertaining the amount of oil contained in the tank may be permitted provided their failure or overfilling will not permit release of fuel.

5 Refrigeration systems for the preservation of the catch

5.1 General

5.1.1 Refrigeration systems are to be so designed, constructed, tested and installed as to take account of the safety of the system and also the emission of chlorofluorocarbons (CFCs) or any other ozone-depleting substances from the refrigerant held in quantities or concentrations which are hazardous to human health or to the environment.

5.1.2 Methylchloride or CFCs whose ozone-depleting potential is higher than 5% of CFC-11 are not to be used as refrigerants.

5.1.3 Adequate guidance for the safe operation of the refrigeration system and emergency procedures are to be provided by means of suitable notices displayed on board the vessel.

5.2 Design of refrigeration systems

5.2.1 Refrigeration systems are to be adequately protected against vibration, shock, expansion, shrinkage, etc. and are to be provided with an automatic safety control device to prevent a dangerous rise in temperature and pressure.

5.2.2 Refrigeration systems in which toxic or flammable refrigerants are used are to be provided with drainage devices leading to a place where the refrigerant presents no danger to the vessel or to persons on board.

5.3 Arrangement of the refrigerating machinery spaces and refrigerating rooms

5.3.1 Separation of spaces

- a) Any space containing refrigerating machinery, including condensers and gas tanks utilising toxic refrigerants, is to be separated from any adjacent space by gas-tight bulkheads. Any space containing refrigerating machinery, including condensers and gas tanks, is to be fitted with a leak detection system having an indicator outside the space adjacent to the entrance and is to be provided with an independent ventilation system and a water-spraying system.
- b) When such containment is not practicable, due to the size of the vessel, the refrigeration system may be installed in the machinery space provided that the quantity of refrigerant used will not cause danger to persons in the machinery space, should all the gas escape, and provided that an alarm is fitted to give warning of a dangerous concentration of gas should any leakage occur in the compartment.

5.3.2 Exits from spaces

In refrigerating machinery spaces and refrigerating rooms, alarms are to be connected to the wheelhouse or control stations or escape exits to prevent persons being trapped. At least one exit from each such space is to be capable of being opened from the inside. Where practicable, exits from spaces containing refrigerating machinery using toxic or flammable gas are not to lead directly into accommodation spaces.

5.4 Breathing apparatus

5.4.1 Where any refrigerant harmful to persons is used in a refrigeration system, at least two sets of breathing apparatus are to be provided, one of which is to be placed in a position not likely to become inaccessible in the event of leakage of refrigerant. Breathing apparatus provided as part of the vessel's fire-fighting equipment may be considered as meeting all or part of this provision provided its location meets both purposes. Where self-contained breathing apparatus is used, spare cylinders are to be provided.

SECTION 5

ELECTRICAL INSTALLATIONS

1 General

1.1 Application

1.1.1 The requirements contained in Part C, Chapter 2 apply to fishing vessels, except for those contained in Pt C, Ch 2, Sec 1, [2], Pt C, Ch 2, Sec 15, [2], Pt C, Ch 2, Sec 3, [2], Pt C, Ch 2, Sec 3, [3], Pt C, Ch 2, Sec 11, [1], Pt C, Ch 2, Sec 11, [2], Pt C, Ch 2, Sec 11, [3], Pt C, Ch 2, Sec 11, [4], and Pt C, Ch 2, Sec 11, [5], which are replaced by all those contained in this Section.

2 Documentation to be submitted

2.1

2.1.1 The documents listed in Tab 1 are to be submitted.

The list of documents requested is to be intended as guidance for the complete set of information to be submitted, rather than an actual list of titles.

The Society reserves the right to request the submission of additional documents regarding unconventional design or where deemed necessary for the evaluation of the system, equipment or components.

Unless otherwise agreed with the Society, documents for approval are to be sent in triplicate if submitted by the shipyard and in four copies if submitted by the equipment supplier. Documents requested for information are to be sent in duplicate.

In any case, the Society reserves the right to require additional copies when deemed necessary.

3 Type approved components

3.1

3.1.1 The following components are to be type approved case-by-case based on submission of adequate documentation and execution of tests:

- electrical cables
- switching devices (circuit-breakers, contactors, disconnectors, etc.) and overcurrent protective devices
- electronic components used for tasks essential to safety.

4 General requirements for system design, location and installation

4.1 Design and construction

4.1.1 The design and construction of electrical installations are to be such as to provide:

- a) the services necessary to maintain the vessel in normal operational and habitable conditions without having recourse to an emergency source of power,
- b) the services essential to safety when failure of the main source of electrical power occurs, and
- c) protection of the crew and vessel from electrical hazards.

Table 1 : Documents to be submitted

No.	I/A (1)	Document
1	A	Single line diagram of main and emergency power and lighting systems.
2	A	Electrical power balance (main and emergency supply).
3	A	Calculation of short-circuit currents for each installation in which the sum of rated power of the energy sources which may be connected contemporaneously to the network is greater than 500 kVA (kW).
4	A	List of circuits including, for each supply and distribution circuit, data concerning the nominal current, the cable type, length and cross-section, the nominal and setting values of the protective and control devices.
5	A	Single line diagram and detailed diagram of the main switchboard.
6	A	Single line diagram and detailed diagram of the emergency switchboard.
7	A	Diagram of the most important section boards and motor control centres (above 100 kW).
8	A	Detailed diagram of the navigation-light switchboard.
(1) A: to be submitted for approval I: to be submitted for information.		

4.2 Main source of electrical power

4.2.1 Where the electrical power constitutes the only means of maintaining auxiliary services essential for the propulsion and safety of the vessel, a main source of electrical power is to be provided which is to include at least two generating sets, one of which may be driven by the main engine. The Society may accept other arrangements having equivalent electrical capability.

4.2.2 The power of these sets is to be such as to ensure the functioning of the services referred to in [4.1.1] a), excluding the power required in fishing activities, processing and preservation of the catch, in the event of any one of the generating sets being stopped. However, in vessels of less than 45 m, in the event of any one of the generating sets being stopped, it is only necessary to ensure the functioning of the services essential for the propulsion and safety of the vessel.

4.2.3 The arrangement of the vessel's main source of electrical power is to be such that the services referred to in [4.1.1] a) can be maintained regardless of the number of revolutions and direction of the main propelling engines or shafting.

4.2.4 Where transformers constitute an essential part of the supply system required by this item, the system is to be so arranged as to ensure continuity of the supply.

4.2.5 The arrangement of the main electric lighting system is to be such that a fire or other casualty in spaces containing the main source of electrical power, including transformers, if any, will not render the emergency lighting system inoperative.

4.2.6 The arrangement of the emergency electric lighting system is to be such that a fire or other casualty in spaces containing the emergency source of electrical power, including transformers, if any, will not render the main lighting system inoperative.

4.2.7 Navigation lights, if solely electrical, are to be supplied through their own separate switchboard and adequate means for the monitoring of such lights are to be provided.

4.3 Emergency source of electrical power

4.3.1 A self-contained emergency source of electrical power located, to the satisfaction of the Society, outside machinery spaces is to be provided and so arranged as to ensure its functioning in the event of fire or other causes of failure of the main electrical installations.

4.3.2 The emergency source of electrical power is to be capable, having regard to starting currents and the transitory nature of certain loads, of serving simultaneously for a period of at least three hours for ships whose length is equal to or greater than 24 m and a period of at least eight hours for ships whose length is equal to or greater than 45 m:

- a) the VHF radio installation and, if applicable:
 - 1) the MF radio installation
 - 2) the ship earth station and
 - 3) the MF/HF radio installation,

- b) internal communication equipment, fire detection systems and signals which may be required in an emergency,
- c) the navigation lights if solely electrical and the emergency lights
 - 1) of launching stations and overside of the vessel,
 - 2) in all alleyways, stairways and exits,
 - 3) in spaces containing machinery or the emergency source of power,
 - 4) in control stations, and
 - 5) in fishing handling and fish processing spaces, and
- d) the operation of the emergency fire pump, if any.

4.3.3 The emergency source of electrical power may be either a generator or an accumulator battery.

4.3.4 Where the emergency source of electrical power is a generator, it is to be provided both with an independent fuel supply and with efficient starting arrangements to the satisfaction of the Society. Unless a second independent means of starting the emergency generator is provided, the single source of stored energy is to be protected to preclude its complete depletion by the automatic starting system.

4.3.5 Where the emergency source of electrical power is an accumulator battery, it is to be capable of carrying the emergency load without recharging whilst maintaining the voltage of the battery throughout the discharge period within plus or minus 12% of its nominal voltage. In the event of failure of the main power supply, this accumulator battery is to be automatically connected to the emergency switchboard and is to immediately supply at least those services specified in [4.3.2] (b) and (c). The emergency switchboard is to be provided with an auxiliary switch allowing the battery to be connected manually, in case of failure of the automatic connection system.

4.3.6 The emergency switchboard is to be installed as near as is practicable to the emergency source of power and is to be located in accordance with [4.3.1]. Where the emergency source of power is a generator, the emergency switchboard is to be located in the same place unless the operation of the emergency switchboard would thereby be impaired.

4.3.7 An accumulator battery, other than batteries fitted for the radio transmitter and receiver in vessels of less than 45 m in length, is to be installed in a well ventilated space which is not to be the space containing the emergency switchboard. An indicator is to be mounted in a suitable place on the main switchboard or in the machinery control room to indicate when the battery constituting the emergency source of power is being discharged.

4.3.8 The emergency switchboard is to be supplied in normal operation from the main switchboard by an interconnector feeder which is to be protected at the main switchboard against overload and short-circuit and which is to be disconnected automatically at the emergency switchboard upon failure of the main source of electrical power. Where the system is arranged for feedback operation, the

interconnector feeder is also to be protected at the emergency switchboard at least against short-circuit.

For ships whose length is equal to or greater than 45 m, the arrangement at the emergency switchboard is to be such that in the event of failure of the main power supply an automatic connection of the emergency supply will be provided.

4.3.9 The emergency generator and its prime mover and any emergency accumulator battery are to be so arranged as to ensure that they will function at full rated power when the vessel is upright and when rolling up to an angle of 22,5° either way and simultaneously pitching 10° by bow or stern, or in any combination of angles within those limits.

4.3.10 The emergency source of electrical power and automation starting equipment is to be so constructed and arranged as to enable adequate testing to be carried out by the crew while the vessel is in operating condition.

4.3.11 For ships whose length is less than 24 m the Society may exempt Owners from the installation of the emergency source of electrical power.

4.4 Precaution against shock, fire and other hazards of electrical origin

4.4.1 Exposed permanently fixed metal parts of electrical machines or equipment which are not intended to be live but which are liable under fault conditions to become live are to be earthed (grounded) unless:

- a) they are supplied at a voltage not exceeding 50 V direct current or 50 V, root mean square between conductors; auto-transformers are not to be used for the purpose of achieving this alternative current voltage, or
- b) they are supplied at a voltage not exceeding 250 V by safety isolating transformers supplying one consuming device only, or
- c) they are constructed in accordance with the principle of double insulation.

4.4.2 Electrical apparatus is to be so constructed and installed that it will not cause injury when handled or touched in the normal manner.

4.4.3 Main and emergency switchboards are to be so arranged as to afford easy access as may be needed to apparatus and equipment, without danger to attendants. The sides, backs and, where necessary, the fronts of switchboards are to be suitably guarded. Exposed live parts having voltages to earth exceeding a voltage to be specified by the Society are not to be installed on the front of the switchboards. There are to be non-conducting mats or gratings at the front and rear, where necessary.

4.4.4 The hull return system of distribution is not to be used for power, heating or lighting in vessels of 75 m of length and over.

4.4.5 The requirement in [4.4.4] does not preclude, under conditions approved by the Society, the use of:

- a) impressed current cathodic protective systems,
- b) limited and locally earthed systems, or
- c) insulation level monitoring devices provided the circulation current does not exceed 30 mA under the most unfavourable conditions.

4.4.6 Where the hull return system is used, all final sub-circuits (all circuits fitted after the last protective device) are to be two-wire and special precautions are to be taken to the satisfaction of the Society.

4.4.7 When a distribution system, whether primary or secondary, for power, heating or lighting, with no connection to earth is used, a device capable of monitoring the insulation level to earth is to be provided.

4.4.8 When a distribution system is in accordance with [4.4.7] and a voltage exceeding 50 V direct current or 50 V, root mean square, between conductors, is used, a device capable of continuously monitoring the insulation level to earth and of giving an audible or visual indication of abnormally low insulation values is to be provided.

4.4.9 Distribution systems which are supplied at a voltage not exceeding 250 V direct current or 250 V, root mean square, between conductors, and which are limited in extent, may comply with [4.4.7], subject to the satisfaction of the Society.

4.4.10 Except as permitted by the Society in exceptional circumstances, all metal sheaths and armour of cables are to be electrically continuous and to be earthed.

4.4.11 All electrical cables are to be at least of a flame-retardant type and are to be so installed as not to impair their original flame-retarding properties. The Society may permit the use of special types of cables where necessary for specific applications, such as radio frequency cables, which do not comply with the foregoing.

4.4.12 Cables and wiring serving essential or emergency power, lighting, internal communications or signals are as far as practicable to be routed clear of galleys, machinery spaces of category A and other high fire risk areas and laundries, fish handling and fish processing spaces and other spaces where there is a high moisture content. Cables connecting fire pumps to the emergency switchboard are to be of a fire-resistant type where they pass through high fire risk areas. Where practicable, all such cables are to be run in such a manner as to preclude their being rendered unserviceable by heating of the bulkheads which may be caused by a fire in an adjacent space.

4.4.13 Where cables are installed in spaces where the risk of fire or explosion exists in the event of an electrical fault, special precautions against such risk are to be taken to the satisfaction of the Society.

4.4.14 Wiring is to be supported in such a manner as to avoid chafing or other damage.

4.4.15 Terminations and joints in all conductors are to be made such that they retain the original electrical, mechanical, flame-retarding and, where necessary, fire-resisting properties of the cable.

4.4.16 Cables installed in refrigerated compartments are to be suitable for low temperatures and high humidity.

4.4.17 Circuits are to be protected against short-circuit. Circuits are also to be protected against overload, unless otherwise specified in these Rules or where the Society may exceptionally otherwise permit.

4.4.18 The rating or appropriate setting of the overload protective device for each circuit is to be permanently indicated at the location of the protective device.

4.4.19 Lighting fittings are to be so arranged as to prevent temperature rises which could damage the wiring and to prevent surrounding material from becoming excessively hot.

4.4.20 Lighting or power circuits terminating in a space where the risk of fire or explosion exists are to be provided with isolating switches outside the space.

4.4.21 The housing of accumulator batteries is to be constructed and ventilated to the satisfaction of the Society.

4.4.22 Electrical or other equipment which may constitute a source of ignition of flammable vapours is not permitted in these compartments except as provided for in [4.4.24].

4.4.23 An accumulator battery is not to be located in accommodation spaces unless installed in a hermetically sealed container.

4.4.24 In spaces where flammable mixtures are liable to collect and in any compartments assigned principally to the containment of an accumulator battery, no electrical equipment is to be installed unless the Society is satisfied that it is:

- a) essential for operational purposes,
- b) of a type which will not ignite the mixture concerned,
- c) appropriate for the space concerned, and
- d) appropriately certified for safe usage in the dusts, vapours or gases likely to be encountered.

4.5 Engineers' alarm

4.5.1 In vessels of 75 m in length and over, an engineers' alarm is to be provided to be operated from the engine control room or at the manoeuvring platform as appropriate, and is to be clearly audible in the engineers' accommodation.

5 Lightning protection

5.1 General

5.1.1 (1/7/2002)

Lightning protection systems are to be fitted to all wooden masts or topmasts.

Part E
Service Notations

Chapter 21
RESEARCH SHIPS

SECTION 1 GENERAL

SECTION 1

GENERAL

1 Application

1.1

1.1.1 (1/7/2004)

Ships complying with the requirements of this Chapter are eligible for the assignment of the service notation **research ship**, as defined in Pt A, Ch 1, Sec 2, [4.8.8].

1.1.2 (1/7/2004)

Ships dealt with in this Chapter are to comply with the requirements stipulated in Parts A, B, C and D, as applicable, and with the specific requirements given in [2].

2 Specific requirements

2.1

2.1.1 (1/7/2004)

Ships are to comply with the specific requirements for supply vessels given in Chapter 15, as applicable, and are to be provided with special equipment and arrangements suitable for scientific or technological research (laboratories, apparatus, accommodation spaces for research personnel, etc).

The above-mentioned equipment and/or arrangements are listed in the Certificate of Classification.

Part E
Service Notations

Chapter 22
PIPE LAYING UNITS

- SECTION 1 GENERAL**
- SECTION 2 HULL AND STABILITY**
- SECTION 3 MACHINERY AND SYSTEMS**

SECTION 1

GENERAL

1 General

1.1 Application

1.1.1 (1/1/2022)

Ships complying with the requirements of this Chapter are eligible for the assignment of the service notation **pipe laying unit**, as defined in Pt A, Ch 1, Sec 2, [4.8.9].

1.1.2 (1/1/2022)

Ships dealt with in this Chapter are to comply with the requirements stipulated in Parts A, B, C and D, as applicable, and with the requirements of this Chapter, which are specific to pipe laying units.

1.2 Summary table

1.2.1 (1/1/2022)

Tab 1 indicates, for ready reference, the Sections of this Chapter containing specific requirements applicable to pipe laying units.

Table 1 (1/1/2022)

Main subject	Reference
Ship arrangement	(1)
Hull and stability	Sec 2
Machinery and systems	Sec 3
Electrical installations	(1)
Automation	(1)
Fire protection, detection and extinction	(1)
(1) No specific requirements for pipe laying units are given in this Chapter	

SECTION 2**HULL AND STABILITY****1 General****1.1 Application****1.1.1 (1/1/2005)**

The requirements of this Section apply to the hull structures, support structures and connecting structures related to pipe laying operations.

1.2 Documents to be submitted**1.2.1 (1/1/2005)**

Tab 1 lists the plans or documents that are to be submitted to the Society, as applicable.

2 Foundation structures, supporting structures and fastening**2.1****2.1.1 (1/1/2005)**

The structures are assessed on a case-by-case basis, considering the structural model, the load model and the checking criteria, as applicable, specified in Part B, Chapter 7.

3 Connecting structures of the stinger to the hull**3.1****3.1.1 (1/1/2005)**

The structures are assessed on a case-by-case basis, considering the design forces provided by the Designer and the checking criteria, as applicable, specified in Part B, Chapter 7.

Table 1 : Documents to be submitted (1/1/2005)

No.	A/I (1)	Document	Containing also information on
1	I	General arrangement of pipe laying equipment	Design loads for all components of pipe laying equipment
2	I	General arrangement of cranes and davits and of the relevant support	Design load for cranes and davits
3	I	Fender arrangement for protection of the side shell	
4	A	Foundation structures, supporting structures and fastening of the equipment for pipe laying operations	Design forces transmitted to the hull structures
5	A	Structures supporting stowed pipes and, if applicable, reels	Design forces transmitted to the hull structures
6	A	Foundation structures of cranes and davits	Design forces transmitted to the hull structures
7	A	Connecting structures of the stinger to the hull	Design forces transmitted to the hull structures
(1) A = to be submitted for approval in four copies I = to be submitted for information in duplicate			

SECTION 3

MACHINERY AND SYSTEMS

1 General

1.1 Application

1.1.1 (1/1/2005)

The requirements of this Section apply to:

- Equipment for the pipe laying
- Equipment for positioning during pipe laying.

1.2 Documents to be submitted

1.2.1 (1/1/2005)

Tab 1 lists the plans or documents that are to be submitted to the Society, as applicable.

2 Pipe laying equipment

2.1

2.1.1 (1/1/2005)

The equipment and installation is considered on a case-by-case basis.

3 Anchoring equipment

3.1

3.1.1 (1/1/2005)

The equipment and installation is considered on a case-by-case basis.

4 Dynamic positioning equipment during pipe laying

4.1

4.1.1 (1/1/2005)

In general, the requirements in Pt F, Ch 13, Sec 6 of the Rules apply.

5 Testing of pipe laying, anchoring and positioning equipment

5.1 Testing of materials

5.1.1 (1/1/2005)

In general testing of materials is required according to the applicable requirements of the Rules.

5.2 Hydraulic tests

5.2.1 (1/1/2005)

Pressure parts are to be subjected to hydraulic tests in accordance with Pt C, Ch 1, Sec 3 and Pt C, Ch 1, Sec 10, as applicable.

5.3 Tests of mechanical components

5.3.1 (1/1/2005)

Running tests of each individual component are to be carried out whenever possible at the Manufacturer's works; as an alternative, the above tests may be performed during equipment trials on board.

5.4 Tests on electrical components

5.4.1 (1/1/2005)

The tests required in Part C, Chapter 2 are to be carried out as applicable.

6 Equipment trials on board

6.1

6.1.1 (1/1/2005)

Tests are to be carried out to verify the proper operation of all machinery and equipment intended for pipe laying, anchoring and dynamic positioning in different sea and weather conditions, if necessary.

Table 1 : Documents to be submitted (1/1/2005)

No.	A/I (1)	Document	Containing also information on
1	A	Plans of all components of the pipe laying equipment including gears, pressure vessels, hydraulic systems etc., indicating materials and welding details	
2	I	General arrangement of the anchoring equipment	Design load for anchoring equipment
3	I	General arrangement of the dynamic positioning equipment during pipe laying	
4	A	Documentation relevant to the dynamic positioning system (see [4])	
(1) A = to be submitted for approval in four copies I = to be submitted for information in duplicate			

Part E
Service Notations

Chapter 23
CEMENT CARRIERS

SECTION 1 GENERAL

SECTION 2 SHIP ARRANGEMENT, HULL AND STABILITY

SECTION 3 MACHINERY AND SYSTEMS

SECTION 1

GENERAL

1 General

1.1 Application

1.1.1 (1/2/2005)

Ships complying with the requirements of this Chapter are eligible for the assignment of the service notation **cement carrier**, as defined in Pt A, Ch 1, Sec 2, [4.2.10].

1.1.2 (1/2/2005)

Ships dealt with in this Chapter are to comply with the requirements stipulated in Parts A, B, C and D, as applicable, and with the requirements of this Chapter, which are specific to cement carriers.

1.2 Summary table

1.2.1 (1/2/2005)

Tab 1 indicates, for ready reference, the Sections of this Chapter containing specific requirements applicable to cement carriers.

Table 1 (1/2/2005)

Main subject	Reference
Ship arrangement	Sec 2
Hull and stability	Sec 2
Machinery and systems	Sec 3
Electrical installations	(1)
Automation	(1)
Fire protection, detection and extinction	(1)
(1) No specific requirements for cement carriers are given in this Chapter.	

SECTION 2

SHIP ARRANGEMENT, HULL AND STABILITY

1 General

1.1 Documents to be submitted

1.1.1 (1/2/2005)

Tab 1 lists the plans or documents that are to be submitted to the Society, as applicable

Table 1 : Documents to be submitted (1/2/2005)

No.	A/I (1)	Document
1	A	Typical loading and unloading sequences, including conditions with uneven distribution (e.g. part loading conditions with empty cargo holds, as applicable)
2	I	Data regarding properties of cement (e.g. bulk density, angle of repose, humidity limits, etc.)
3	I	Loading and unloading systems manual
(1) A = to be submitted for approval in four copies I = to be submitted for information in duplicate		

2 Ship arrangement

2.1 General

2.1.1 (1/2/2005)

Cement carriers are to be fitted with a closed loading and unloading system.

2.1.2 (1/2/2005)

In general, the cement carrier holds are to be fitted with a double bottom, a single or double side and a single deck. Hatches to cargo holds are intended for access only or for arrangement of the loading and unloading system.

3 Corrosion additions

3.1 General

3.1.1 (1/2/2005)

In lieu of the values specified in Pt B, Ch 4, Sec 2, [3], the corrosion addition relevant to dry bulk cargo holds intended to carry cement only is to be taken equal to 1,0 mm.

4 Stability

4.1 Intact stability

4.1.1 (1/2/2005)

Ships carrying cement having an angle of repose $\Phi \leq 30^\circ$ are to comply with the stability requirements of Ch 4, Sec 3,

[2.2] relevant to grain loading. As an alternative, the cement is to be trimmed as indicated in [4.1.2] and the ship is to remain alongside for twelve hours to allow escape of entrained air and the settlement of the cargo.

4.1.2 (1/2/2005)

Ships carrying cement having an angle of repose $30^\circ < \Phi \leq 35^\circ$ may not comply with the requirements of [4.1.1] provided that the cargo is trimmed according to the following criteria:

- the unevenness of the cargo surface measured as the vertical distance (Δh) between the highest and lowest levels of the cargo surface is not to exceed $B/10$, where B , in m, is the beam of the ship with a maximum allowable $\Delta h = 1,5\text{m}$;
- where Δh cannot be measured, bulk shipment can also be accepted if loading is carried out with suitable trimming equipment.

4.1.3 (1/2/2005)

Ships carrying cement having an angle of repose $\Phi > 35^\circ$ are to be loaded in such a way that the cement is distributed in a manner which eliminates the formation of wide, steeply sloped voids beyond the trimmed surface within the boundaries of the cargo space. The cement is to be trimmed to an angle significantly less than the angle of repose..

4.1.4 (1/2/2005)

Suitable arrangements are to be provided to check that the cargo is properly trimmed and levelled as requested in [4.1.2] and [4.1.3].

5 Design loads

5.1 Internal pressures due to cement cargo

5.1.1 (1/2/2005)

The still water and inertial pressures induced by the cement cargo on the hold structures are to be calculated in accordance with Pt B, Ch 5, Sec 6, [3], on the basis of the cement cargo density and angle of repose.

5.2 Loading conditions to be considered in structural analyses of primary supporting members based on three dimensional models

5.2.1 (1/2/2005)

Where primary supporting members are analysed through three dimensional models, in accordance with Pt B, Ch 7, Sec 3, the following loading conditions are to be consid-

ered when defining the loads acting on the structural elements represented in the model:

- homogeneous loading conditions,
- ballast loading conditions,
- the most severe non-uniform loading conditions, in which the cargo is unevenly distributed in the cargo holds, at the relevant design draughts,
- the most severe harbour loading conditions, as they result from the various steps envisaged by the loading and unloading sequences.

SECTION 3

MACHINERY AND SYSTEMS

1 General

1.1 Documents to be submitted

1.1.1 (1/2/2005)

Tab 1 lists the plans or documents that are to be submitted to the Society, as applicable

2 Cement handling system

2.1 General

2.1.1 Mechanical strength (1/2/2005)

The systems intended for loading and unloading operations and their components (such as conveyors) are to be of sufficient mechanical strength based on the maximum loads expected in service, as specified by the Designer, and are not subject to specific class requirements.

2.1.2 Piping systems (1/2/2005)

The piping systems intended for cement handling and ancillary systems are to be designed, constructed and tested in accordance with the applicable provisions of Pt C, Ch 1, Sec 10.

2.1.3 Pressure vessels (1/2/2005)

Where provided, pressure vessels are to be designed, constructed and tested in accordance with the applicable provisions of Pt C, Ch 1, Sec 3.

3 Testing of cement handling equipment

3.1 Workshop testing

3.1.1 General (1/2/2005)

The cement handling equipment is to be tested in compliance with the following requirements, with the exception of prime movers and pressure vessels, which are to be tested in compliance with the applicable requirements of the relevant Sections of Part C.

3.1.2 Testing of materials and components of the machinery (1/2/2005)

- a) In general, testing is required for shafts, gearing, pressure parts of pumps and hydraulic motors, and plates of foundations of welded construction.
- b) As far as mechanical tests of materials are concerned, internal works' certificates submitted by the Manufacturer may be accepted by the Society at its discretion. In such cases, testing operations may be limited to visual external inspection associated, where necessary, with non-destructive examinations and hardness tests.

3.1.3 Hydrostatic tests (1/2/2005)

Pressure parts are to be subjected to hydrostatic tests in accordance with the relevant requirements of Pt C, Ch 1, Sec 3 or Pt C, Ch 1, Sec 10, as appropriate.

3.1.4 Tests on electrical components (1/2/2005)

The tests required in Part C, Chapter 2 are to be carried out as applicable.

3.1.5 Running tests (1/2/2005)

- a) Running tests are to be carried out whenever possible at the Manufacturer's works. As an alternative, the above tests may be performed on board during the trials required after installation of machinery.
- b) During the running tests, the suitability of all the arrangements concerned is to be checked in relation to the various expected service conditions.
- c) On completion and subject to the result of the above tests, the inspection of components may be required, with dismantling where deemed necessary by the Surveyor in charge of the testing.

3.2 On board testing

3.2.1 Equipment trials (1/2/2005)

As far as the cement handling system is concerned, tests are to be carried out to verify the proper operation of all relevant equipment.

Table 1 : Documents to be submitted (1/2/2005)

No.	A/I (1)	Document (2)
1	I	General arrangement of the cement handling equipment
2	I	Design loads on all components of the cement handling equipment
3	A	Plans of all components of the cement handling equipment, including pressure vessels, hydraulic systems, etc, as applicable
4	A	Diagram of the piping system intended for cement handling
<p>(1) A = to be submitted for approval in four copies I = to be submitted for information in duplicate</p> <p>(2) Diagrams are also to include, where applicable, the (local and remote) control and monitoring systems and automation systems</p>		

COMPRESSED NATURAL GAS (CNG) CARRIERS

SECTION 1	GENERAL
SECTION 2	SHIP ARRANGEMENT
SECTION 3	SHIP SURVIVAL CAPABILITIES
SECTION 4	CARGO CONTAINMENT
SECTION 5	PROCESS PRESSURE VESSELS AND PIPING SYSTEMS
SECTION 6	MATERIALS FOR CONSTRUCTION
SECTION 7	OVERPRESSURE PROTECTION FOR CARGO CONTAINMENT AND PIPING SYSTEM
SECTION 8	ENVIRONMENTAL CONTROL
SECTION 9	ELECTRICAL INSTALLATIONS
SECTION 10	FIRE PROTECTION AND FIRE EXTINCTION
SECTION 11	MECHANICAL VENTILATION IN THE CARGO AREA
SECTION 12	INSTRUMENTATION (GAUGING, GAS DETECTION)
SECTION 13	USE OF CARGO AS FUEL
SECTION 14	SPECIAL REQUIREMENTS
SECTION 15	ADDITIONAL INFORMATIONS ON PRODUCTS

SECTION 1 GENERAL

1 General

1.1 Application

1.1.1 (1/7/2012)

Ships complying with the requirements of this Chapter are eligible for the assignment of the service notation **Compressed Natural Gas Carrier**, as defined in Pt A, Ch 1, Sec 2, [4.2.11]. The reference CNG carrier is a double hull construction with double side and double bottom, with holds containing the CNG in separate pressure vessels, equipped with loading/unloading systems, without turret systems. Different ship arrangements may require ad-hoc considerations in addition to, or in lieu of the present Rules.

Ships dealt with in this Chapter are to comply with the requirements stipulated in Parts A, B, C and D of the Rules, as applicable, and with the requirements of this Chapter, which are specific to Compressed Natural Gas Carrier. These requirements are intended to apply ships regardless of their size, including those of less than 500 tons gross tonnage, engaged in carriage of Compressed Natural Gas.

1.1.2 IGC Code (1/7/2012)

In this Chapter, reference to the latest version of the International Code for the Construction and Equipment of Ships Carrying Liquefied Gases in Bulk, as amended, is made by the wording "IGC Code".

1.1.3 Compressed Natural Gas (CNG) (1/7/2012)

Is intended as a mixture typically composed of Methane, Natural Gas Liquids (ethane, propane, butane, pentane, etc), water, carbon dioxide, nitrogen and other non-hydrocarbon contaminants (e.g. H₂S). Cargo is the various compositions of natural gas that will be carried. For the carriage in bulk of products which are not listed in this Chapter, presenting more severe hazards than those covered by the Rules, the Society reserves the right to establish requirements and/or conditions additional to those contained in this Chapter.

1.1.4 Carriage of products not listed in Section 15 (1/7/2012)

The carriage of products not listed in Sec 15, Tab 1 will be considered on a case by case basis by the Society.

1.1.5 Gas contaminants (1/7/2012)

The requirements relating to the cargo tanks apply only to CNG. The cargo that comes into contact with the cargo tanks and loading/unloading system of the ship is to have water, carbon dioxide, nitrogen and other contaminants removed. If this is not feasible, and the cargo has a presence of contaminants, these must be evaluated and additional measures, not covered in this Chapter, will be required. In particular, at least the scantlings may need to be suitably

increased or an effective method of corrosion control is to be adopted and the design assessed for their effects.

1.1.6 Hazards (1/7/2012)

Hazards of Compressed Natural Gas considered in this Chapter include fire, toxicity, corrosibility, reactivity, temperature and pressure.

1.2 Fundamental safety requirements

1.2.1 (1/7/2012)

The overall safety and security is to be demonstrated to be equivalent or better than comparable liquefied gas carriers built and operated according to Chapter 9.

1.2.2 (1/7/2012)

For new concepts, it is recommended to follow the procedure for the Approval in Principle or for the Technology Qualification (see the "Guide for Technology Qualification Processes"). A significant role in such procedure is played by Risk Assessment is to be submitted. The Risk Assessment is to comply with the principles outlined in the "Guide for Risk Analysis". The choice of a qualitative or quantitative analysis depends on the problem to be studied, but it is likely that at least evaluations of consequences of fire and gas dispersion scenarios will be needed. Modifications to existing systems (e.g. cargo holds, cargo piping, process system, operational procedures etc.) are to be supported by at least a Hazard Identification (HAZID) or other appropriate studies. The whole documentation supporting the design, i.e. risk assessment, engineering studies, tests etc. is to be submitted to the Society for information, as a part of the classification documentation.

1.2.3 (1/7/2012)

The safety requirements are to be based on safety objectives for:

- life (crew and third party personnel)
- environment (oil pollution, gas release to the atmosphere).

Commercial requirements such as availability may be included, if agreed with the Interested Party.

2 Definitions

2.1 Terms

2.1.1 Blow down (1/7/2012)

Means the controlled depressurization of an inventory of pressurised gas.

2.1.2 Cargo area (1/7/2012)

Is that part of the ship which contains the cargo containment and cargo handling systems and includes deck areas over the full length and breadth of the part of the ship over the above-mentioned spaces.

2.1.3 Cargo hold (1/7/2012)

Is the space enclosed by the ship's structure in which cargo tanks are placed.

2.1.4 Cargo hold vent pipes (1/7/2012)

Are low pressure pipes for venting of cargo hold spaces.

2.1.5 Cargo load/unload valve (1/7/2012)

Is the valve isolating the cargo piping from external piping.

2.1.6 Cargo piping (1/7/2012)

Is the piping between the cargo tank valve and the cargo load and or unload valve.

2.1.7 Cargo tank (1/7/2012)

Is all pressurised equipment (e.g. cargo container, manifold piping etc.) of a cargo containment system up to the first isolating cargo tank valve.

2.1.8 Cargo tank valve (1/7/2012)

Is the valve isolating the cargo tank from the cargo piping.

2.1.9 Design pressure (1/7/2012)

Is the maximum gauge gas pressure at the top of the cargo tank which has been used in the calculation of the scantlings of the cargo tank and cargo piping, at the expected operating environmental conditions.

2.1.10 Maximum Allowable Working Pressure (1/7/2012)

Is the maximum pressure, corresponding to the relevant temperature, which is allowed during normal operations like storage, loading and unloading. It is 95% of the design

pressure. The normal working pressure is not to exceed the maximum allowable working pressure.

2.1.11 Design temperature (1/7/2012)

For the selection of materials in cargo tanks, piping, supporting structure and inner hull structure is the lowest or highest temperature which can occur in the respective components.

3 Additional requirements

3.1 Emergency towing arrangement

3.1.1 (1/7/2012)

Emergency towing arrangements are to be fitted in accordance with Pt B, Ch 10, Sec 4, [4], irrespective of the deadweight of the ship..

3.2 Steering gear

3.2.1 (1/7/2012)

Additional requirements for steering gear are given in Ch 7, Sec 4, [7].

4 Documentation to be submitted

4.1

4.1.1 (1/7/2012)

Tab 1 and Tab 2 list the plans, information, analysis, etc. which are to be submitted in addition to the information required in the other Parts of the Rules for the parts of the ship not affected by the cargo, as applicable.

Table 1 : Documents to be submitted: General (1/7/2012)

No	A/I (1)	Documents
1	I	List of products to be carried, gas technical specification and all design conditions
2	I	General arrangement plan, showing location of cargo tanks and fuel oil, ballast and other tanks
3	A	Gas-dangerous zones plan
4	A	Location of void spaces and dangerous zones
5	A	Air locks between safe and dangerous zones
6	A	Ventilation duct arrangement in gas-dangerous spaces and adjacent zones
7	A	Details of hull structure in way of cargo tanks, including support arrangement for tanks, saddles, anti-floating and anti-lifting devices, deck sealing arrangements, etc.
8	A	Hull stress analysis
9	A	Hull ship motion analysis, where a direct analysis is preferred to the methods indicated in Sec 4
10	A	Intact and damage stability calculations
11	A	Cargo tanks and cargo piping systems
12	A	Cargo control room
13	A	Details of ladders, fittings and towers in tanks and relative stress analysis, if any
14	A	Bilge and ballast system in cargo area
15	A	Gas freeing system in cargo tanks including inert gas system
16	A	Interbarrier space drainage, inerting and pressurisation systems
17	A	Ventilation system in cargo area
18	A	Hull structure heating system, if any
19	A	Refrigeration and reliquefaction plant system diagram, if any
20	A	Details of electrical equipment installed in cargo area, including the list of certified safe equipment and apparatus and electrical bonding of cargo tanks and piping
21	A	Schematic electrical wiring diagram in cargo area
22	A	Gas detection system
23	A	Cargo tank instrumentation, including cargo and hull temperature monitoring system
24	A	Emergency shutdown system
25	A	Details of fire-extinguishing appliances and systems in cargo area
26		For machinery using gas as fuel:
	I	a) General arrangement plan of the machinery plant
	I	b) Description of the entire plant
	A	c) Gas piping plans for the machinery plant
	A	d) Complete list of the safety, gas detection and warning equipment
	A	e) Drawings of the boilers
	I	f) Detailed drawings of the gas inlet and fuel inlet equipment
	I	g) Gas characteristics
	A	h) General arrangement plan of the gas treatment plant, including gas compressors, prime movers and gas preheaters
	A	i) Drawings of the gas compressors and preheaters
Note 1: A = to be submitted for approval in four copies		
I = to be submitted for information in duplicate		

Table 2 : Documents to be submitted: Cargo Tanks and piping (1/7/2012)

No	A/I (1)	Documents
1	A	Drawing of tanks, non-destructive testing of welds and strength and tightness testing of tanks
2	A	Design loads and structural analysis of cargo tanks
3	A	Calculation of maximum and minimum design temperature for materials in the cargo tank, supporting structure and inner hull due to loading/unloading/depressurizing
4	A	Prototype testing with full scale fatigue and burst test for cargo tank
5	A	Fatigue crack propagation calculations for the cargo tank piping
6	A	Drawings and calculation of stresses in the cargo tank piping including vibrations and fatigue analysis
7	A	Drawings and calculation of supports for cargo tank cylinders including collision loads
8	I	Operational and emergency procedures for possible incidents in the cargo tanks
9	A	Overpressure protection arrangements for cargo tanks including details of pressure relief devices
10	I	Arrangements and procedure for gas freeing and mechanical ventilation in cargo area
11	A	Scantlings, material and arrangement of the cargo tanks including the liner
12	A	Stress analysis of the cargo tanks, including fatigue analysis and crack propagation analysis for type "B" tanks. This analysis may be integrated with that indicated in item 10
13	A	Details of cargo handling and vapour system, including arrangements and details of piping and fitting
14	A	Details of process pressure vessels and relative valves arrangement
15	A	Details of cargo pumps and cargo compressors
16	A	Blow down system, if any
17	A	Emergency shutdown provisions and arrangements
18	A	Loading and unloading operation description, including cargo tank filling limits
19	A	Cargo tank testing and inspection procedures
20	A	Supporting documentation (risk assessment, engineering analyses, tests etc.)
Note 1: A = to be submitted for approval in four copies I = to be submitted for information in duplicate		

SECTION 2

SHIP ARRANGEMENT

1 Segregation of the cargo area

1.1 Segregation of hold spaces

1.1.1 (1/7/2012)

No accommodation space, service space or control station is to be located within the cargo area. The bulkheads of accommodation spaces, service spaces or control stations which face the cargo area are to be so located as to avoid the ingress of gas from the hold space to such spaces through a single failure of a deck or bulkhead.

1.2 Location of cargo holds

1.2.1 General (1/7/2012)

Cargo holds are to be segregated, by means of cofferdams, from machinery and boiler spaces, accommodation spaces, service spaces and control stations, chain lockers, drinking and domestic water tanks and from stores. For a conventional ship type, cargo holds are to be located forward of machinery spaces of category A. Bow thrusters, if fitted, may be located forward of the hold spaces. Further requirements may stem from the risk analysis.

Access and spaces for a safe visual and/or instrumental inspection of cargo tanks is to be provided, and the relevant inspection plan is to be sent to the Society for information.

2 Accommodation, service and machinery spaces and control stations

2.1 General

2.1.1 (1/7/2012)

If the ship is gas-fuelled, Pt C, Ch 1, App 7 applies.

2.1.2 Precautions against hazardous vapours (1/7/2012)

In order to guard against the danger of hazardous vapors, due consideration is to be given to the location of air intakes, air outlets and openings into accommodation, service and machinery spaces and control stations in relation to cargo piping, cargo vent systems and machinery space exhausts from gas burning arrangements. For this purpose, IGC Code 3.2.4, 3.8, 8.2.10 and 12.1.6 apply to the aforesaid air intakes, air outlets and openings.

2.1.3 Spaces located forward of the cargo area (1/7/2012)

IGC Code Ch 3, 3.2.6 applies, with the following additional requirements.

Entrances and openings to service spaces located forward of the cargo area may not face such area.

2.1.4 Doors facing cargo area (1/7/2012)

IGC Code Ch 3, 3.2.4 applies, with the following additional requirements.

Doors facing the cargo area or located in hazardous areas on the sides are to be restricted to stores for cargo-related and safety equipment, cargo control stations as well as decontamination showers and eye wash.

Where such doors are permitted, the space may not give access to other spaces covered in IGC Code 3.2.4 and the common boundaries with these spaces are to be insulated with A60 class bulkheads.

2.1.5 Exemptions, ventilation openings and type of closures (1/7/2012)

IGC Code Ch 3, 3.2.6 applies, with the following additional requirements.

The requirement for fitting air intakes and openings with closing devices operable from inside the space in ships intended to carry toxic products is to apply to spaces which are used for the ship's radio and main navigating equipment, cabins, mess rooms, toilets, hospitals, galleys, etc., but does not apply to spaces not normally manned such as deck stores, forecastle stores, engine room casings, steering gear compartments and workshops. The requirement does not apply to cargo control rooms located within the cargo area.

When internal closing is required, this is to include both ventilation intakes and outlets.

The closing devices are to give a reasonable degree of gas-tightness. Ordinary steel fire-flaps without gaskets/seals are normally not considered satisfactory.

2.1.6 Openings for removal of machinery (1/7/2012)

IGC Code Ch 3, 3.2.6 applies, with the following additional requirements.

Bolted plates of A60 class for removal of machinery may be accepted on bulkheads facing cargo areas, provided signboards are fitted to warn that these plates may only be opened when the ship is in gas-free condition.

SECTION 3

SHIP SURVIVAL CAPABILITIES

1 Freeboard and intact stability

1.1 Intact stability

1.1.1 (1/7/2012)

The stability of the ship for the loading conditions in Pt B, Ch 3, App 2, [1.2.3] is to be in compliance with the requirements in Pt B, Ch 3, Sec 2.

1.1.2 (1/7/2012)

The cargo holds are to be protected from penetration in the case of minor damage to the vessel (resulting, for example, from contact with a jetty or tug) and given a measure of protection from damage in the case of collision or stranding by locating them at specified minimum distances inboard from the vessel's shell plating.

1.1.3 (1/7/2012)

The Master of the ship is to be supplied with a Trim and Stability booklet as specified in Pt B, Ch 3, App 2.

1.2 Damaged stability

1.2.1 (1/7/2012)

A probabilistic approach to determining the effects of a collision or grounding is to be considered according to SOLAS Ch II-1 (MSC.Res. 216(82)).

2 Collisions and groundings

2.1 General

2.1.1 (1/7/2012)

For conventional double bottom designs the double bottom height is to be at least $B/15$ or 3,0 m whichever is less, but not less than 1,0 m.

For conventional double side designs the width of the double side shall at least be minimum $B/15$ or 2.0 m, whichever is the greater.

The above criteria are to be integrated, and possibly superseded, by the additional requirements that may stem from the collision/grounding analysis.

The collision/grounding analysis is to be carried out according to recognized standards and tools, and the Society is to be involved up front and kept informed on the development of the analysis.

The collision analysis is to take into account at least the following aspects:

- a) Sizes, types and speed of vessels that may strike the CNG ship, obtained from traffic data of the typical CNG ship trade;
- b) Assumptions on collision angles, speed and bow rigidity of the striking vessel.

The grounding analysis is to obtain the raking damage on the basis of an assumed navigating speed and an assumed rock shape.

Other assumptions may be made to the satisfaction of the Society.

Collision and grounding analyses, with the assumptions, calculations, results and conclusions clearly stated, are to be sent to the Society for information.

3 Pipes, ducts and trunks in damaged zones

3.1 Strength of internal structures

3.1.1 (1/7/2012)

Tunnels, ducts, pipes, doors, bulkheads and decks which might form watertight boundaries of intact spaces in the case of assumed conventional damage are to have minimum strength adequate to withstand the pressure height corresponding to the deepest equilibrium waterline in damaged conditions.

SECTION 4

CARGO CONTAINMENT

1 General

1.1 Application

1.1.1 (1/7/2012)

Cargo tank design is to be evaluated by the Society to determine the design criteria that are to be followed. Since large CNG tanks are a novel application on ships, it is recommended to follow the procedure for the Approval in Principle or for the Technology Qualification (see the "Guide for Technology Qualification Processes").

1.1.2 (1/7/2012)

Whatever the type (e.g. metal, composite, coiled etc.), cargo tanks are to be designed using recognized standards, model tests, refined analytical tools and analysis methods to determine stress levels, fatigue life and crack propagation characteristics, which are to be submitted by the Society for approval. The uncertainties of the design standards and codes are to be included in the establishment of the design pressure.

1.1.3 (1/7/2012)

The cargo tanks, along with their supports, clamps, piping and other fixtures are to be designed taking into account at least the following loads:

- internal pressure
- external pressure
- wave loads
- thermal loads
- still water loads
- tank and cargo weight with the corresponding reactions in way of supports
- insulation mass, if any
- vibrations.

1.1.4 (1/7/2012)

In particular, thermal loads are to be determined considering the lowest temperature to which the cargo tank will normally be exposed in service during loading, unloading and storage, along with any accidental cargo release causing jet impingement with cooldown effect to nearby tanks. Appropriate calculations or experimental results are to be submitted to the Society for information. Moreover, transient thermal loads and dynamic effect of pressure variations during loading and unloading are to be considered, taking into account the maximum values they will be exposed to during their lifetime.

1.1.5 (1/7/2012)

Cargo tank supports are to comply with the applicable criteria of Ch 9, Sec 4. The loads due to ship motions are to comply with Pt B, Ch 5, Sec 3, and are to be verified by adopting the criteria of Part B, Chapter 7 (in particular, Pt B, Ch 7, App 1 and Pt B, Ch 7, App 3), as applicable.

1.1.6 (1/7/2012)

Special considerations are to be given to loading rates for cargo tanks made of composites, since these materials have rate dependent properties.

1.1.7 (1/7/2012)

Changes to material properties with time due to action of long term still water loads and the environment is also to be considered for composites. The extent to which such loads are to be considered depends on the type of tank.

SECTION 5 PROCESS PRESSURE VESSELS AND PIPING SYSTEMS

1 Gas-fuelled ship

1.1 Application

1.1.1 (1/7/2012)

If the ship is gas-fuelled, Pt C, Ch 1, App 7 applies.

2 Process pressure vessels

2.1 General

2.1.1 (1/7/2012)

Process pressure vessels handling cargo are to be considered at least as class 1 pressure vessels, in accordance with Pt C, Ch 1, Sec 3, [1.4.1].

3 Cargo and process piping

3.1 General

3.1.1 (1/7/2012)

In general, the cargo piping system, as a minimum, is to meet the requirements given in Pt C, Ch 1, Sec 10, [1.3.2], Pt C, Ch 1, Sec 10, [2.5.4], Pt C, Ch 1, Sec 10, [2.9.1], or a standard acceptable to the Society with the following additional requirements.

- a) In general, cargo holds should not have piping in common. Otherwise, precautions are to be taken to avoid that a gas release from a pipe in a hold may leak into other holds.
- b) Considerations are to be made regarding the cooldown (i.e. Joule-Thomson) effect on nearby structural elements due to gas leaks from sources like joints and fittings.
- c) Enclosed spaces in which cargo piping may run are to be protected against overpressure due to high pressure leaks.
- d) The pipes are to be seamless or equivalent. Flange connections are to be limited as far as possible.
- e) Piping system materials (pipes, fittings and flanges) are to be tested at the presence of a surveyor of the Society.
- f) Only butt welded and flanged connections of the welding neck type are allowed.
- g) All butt welds are to be subject to 100% radiographic testing.
- h) Approval of the welding procedure specifications are required as specified in Part D.
- i) After assembly the piping system is to be hydrostatic pressure tested to at least 1.5 times design pressure prior to installation

- j) After assembly on board the complete cargo piping shall be subjected to a leak test using air, halides or other suitable medium according to an approved procedure.

Procedures for cargo transfer including emergency procedures are to be submitted for information. The procedures are to address potential accidents related cargo transfer, and information regarding emergency disconnection, emergency shutdown, communication with offshore/onshore terminals etc. are to be included.

3.1.2 Provisions for protection of piping against thermal stress (1/7/2012)

IGC Code Ch 5, 5.2.1.2 applies, with the following additional requirements.

Expansion joints are to be protected from extensions and compressions greater than the limits fixed for them and the connected piping is to be suitably supported and anchored. Bellow expansion joints are to be protected from mechanical damage.

3.1.3 Segregation of high temperature piping (1/7/2012)

IGC Code Ch 5, 5.2.1.3 applies, with the following additional requirements.

High temperature pipes are to be thermally isolated from the adjacent structures. In particular, the temperature of pipelines is not to exceed 220 °C in gas-dangerous zones.

3.1.4 Pressure relief valve setting (1/7/2012)

Pt C, Ch 1, Sec 3, [2.4.2] applies.

3.1.5 Means for detecting the presence of liquid cargo (if a liquid separation system is fitted) (1/7/2012)

IGC Code Ch 5, 5.2.1 applies as far as practicable, with the following additional requirements.

The means to detect the presence of liquid cargo may be constituted by electrical level switches whose circuit is intrinsically safe. The alarm signals given by the level switches are to be transmitted to the wheelhouse and to the cargo control station, if provided.

3.1.6 Connections of relief valve discharges to cargo tanks (1/7/2012)

If relief valves are fitted on the liquid phase piping, the connections from such relief valve discharges up to process tanks are not to be fitted with shut-off valves, but are to be provided with non-return valves in the proximity of the tanks.

3.2 Scantlings based on internal pressure

3.2.1 Piping subject to green seas (1/7/2012)

IGC Code Ch 5, 5.2.2 applies as far as practicable, with the following additional requirements.

For piping subject to green seas, the design pressure P , in bar, in the formula in 5.1.1 of the IGC CODE is to be replaced by an equivalent pressure P' given by the following formula:

$$P' = \frac{1}{2} \left(P + \sqrt{P^2 + 0,006 R' K \frac{D_c}{D}} \right)$$

where:

D_c : External diameter of the pipe taking into account the insulation (in mm), whose thickness is to be taken at least equal to:

40 mm if $D \leq 50$ mm

80 mm if $D \geq 150$ mm

Intermediate values are to be determined by interpolation.

R' : Drag corresponding to the effect of green seas, in da N/m², such as given in Tab 1 as a function of the location of the pipes and of their height H (in m) above the deepest loadline; intermediate values are to be determined by interpolation.

K : permissible stress, in N/mm²

3.2.2 Design pressure and temperature definition (1/7/2012)

The design temperature is to be the minimum temperature achieved during all normal and emergency procedures e.g. loading/unloading and pressure relieving are to be considered.

The design pressure is the maximum pressure to which the system may be subjected to in service e.g. the set point of the safety relief valve.

3.3 Permissible stress

3.3.1 Flanges not complying with standards (1/7/2012)

For flanges not complying with a standard, the dimensions and type of gaskets are to be to the satisfaction of the Society.

3.3.2 Stress analysis (1/7/2012)

If stresses due to particular conditions (e.g. thermal effects) are to be taken into account, ad-hoc analyses are to be examined by the Society on a case by case basis.

3.3.3 Stress intensity (1/7/2012)

The stress intensity is to be determined as specified in the formulae in Pt C, Ch 1, Sec 10, [2.3.2] for pipes intended for high temperatures:

- a) for primary stresses resulting from:
 - pressure
 - weight
 - green seas
- b) for primary stresses and secondary stresses resulting from contraction or linear dilatation.

3.3.4 Stress intensity limits (1/7/2012)

The stress intensity is to be determined as specified in the formulae in Pt C, Ch 1, Sec 10, [2.3.2] for pipes intended for high temperatures:

- a) For the first case, the stress intensity is to be limited to the lower of:
 - 0,8 R_e and 0,4 R_m
- b) For the second case, the stress intensity is to be limited to the lower of:
 - 1,6 R_e and 0,8 R_m .

3.3.5 Piping with expansion devices (1/7/2012)

For piping fitted with expansion devices, their characteristics are to be submitted to the Society. Where these characteristics are such that the forces and moments at the ends of the devices are negligible for the contraction they must absorb, the calculation of the loads due to contraction in the corresponding piping is not required. It is, however, to be checked that the stress intensity corresponding to the primary stresses does not exceed the limits given in [3.3.4].

Table 1 (1/7/2012)

External diameter of pipe (1)	Aft of the quarter of the ship's length			Forward of the quarter of the ship's length		
	H ≤ 8	H = 13	H ≥ 18	H ≤ 8	H = 13	H ≥ 18
≤ 25	1500	250	150	2200	350	150
50	1400	250	150	2000	350	150
75	1100	250	150	1600	350	150
100	700	250	150	700	350	150
≥ 150	500	250	150	700	350	150

(1) D_c if the pipe is insulated, D otherwise.

3.3.6 Flexibility coefficient (1/7/2012)

The flexibility coefficient of elbows is to be determined from the formulae given in Pt C, Ch 1, Sec 10, [2.3.2] for pipes intended for high temperatures.

3.3.7 Local stresses (1/7/2012)

Particular attention is to be paid to the calculation of local stresses in the assemblies subjected to axial forces and bending moments. The Society reserves the right to request additional justifications or local strengthening where considered necessary.

3.4 Aluminised pipes

3.4.1 (1/7/2012)

Aluminised pipes may be fitted in ballast tanks, in inerted cargo tanks and, provided the pipes are protected from accidental impact, in hazardous areas on open deck.

4 Tests of piping components and pumps prior to installation on board

4.1 Valves

4.1.1 Prototype Testing (1/7/2012)

IGC Code Ch 5, 5.3 applies as far as practicable, with the following additional requirements.

During the unloading phase, the cooldown due to the Joule-Thomson effect is to be taken into account. either through a heating system, (which is to be considered as essential) or through material selection. In the latter case, each size and type of valve intended to be used at a working temperature below -55°C is to be approved through design assessment and prototype testing. Prototype testing to the minimum design temperature or lower and to a pressure not lower than the maximum design pressure foreseen for the valves is to be witnessed in the presence of the Society's Surveyor. Prototype testing is to include a hydrostatic test of the valve body at a pressure equal to 1.5 times the design pressure, seat and stem leakage test at a pressure equal to 1.1 times the design pressure, and cryogenic testing consisting of valve operation and leakage verification.

For valves intended to be used at a working temperature above -55°C , prototype testing is not required.

5 Liquid transfer pumps

5.1 General

5.1.1 (1/7/2012)

This section applies in case a system for separation of the liquid fractions is fitted onboard.

5.2 Prototype Testing

5.2.1 (1/7/2012)

Each size and type of pump is to be approved through design assessment and prototype testing. Prototype testing is to be witnessed in the presence of the Society's Surveyor. In lieu of prototype testing, satisfactory in-service experience

of an existing pump design approved by a QSCS Classification Society submitted by the Manufacturer may be considered.

Prototype testing is to include a hydrostatic test of the pump body equal to 1.5 times the design pressure and a capacity test. For submerged electric motor driven pumps, the capacity test is to be carried out with the design medium or with a medium below the minimum working temperature.

5.3 Unit Production Testing

5.3.1 Pumps (1/7/2012)

All pumps are to be tested at the Manufacturer's plant in the presence of the Society's Surveyor. Testing is to include a hydrostatic test of the pump body equal to 1.5 times the design pressure and a capacity test. For submerged electric motor driven pumps, the capacity test is to be carried out with the design medium or with a medium below the minimum working temperature.

As an alternative to the above, if so requested by the relevant Manufacturer, the certification of a pump may be issued subject to the following:

- the pump has been approved as required by [3.3.1] and
- the Manufacturer has a recognised quality system that has been assessed and certified by the Society subject to periodical audits, and
- the quality control plan contains a provision to subject each pump to a hydrostatic test of the pump body equal to 1.5 times the design pressure and a capacity test. The Manufacturer is to maintain records of such tests.

5.3.2 Centrifugal pumps (1/7/2012)

Overpressure relief valves on cargo pumps may be omitted in the case of centrifugal pumps having a maximum delivery head, the delivery valve being completely closed, not greater than that permitted for the piping.

6 Cargo valves

6.1 General

6.1.1 (1/7/2012)

Cargo valves are to be so designed as to ensure a quick isolation in case of gas leak detection. For this purpose, the following specific requirements apply.

- a) All remotely operated valves are to be capable of local manual operation.
- b) Each cargo tank is to be isolated from the cargo piping by a manually operated stop valve and a remotely operated valve in series.
- c) The loading/unloading connection point is to be equipped with a manually operated stop valve and a remotely operated valve in series.
- d) The remotely operated isolation valves and are to be actuated by the emergency shutdown (ESD) system, in case of high pressure, sudden pressure drop during loading/unloading operations and fire. The ESD valves

are to be arranged to be operated manually from cargo control room and other suitable locations

- e) The valve sizing and operating time is to take into account surge phenomena.
- f) The cargo compressors are to shutdown automatically if the ESD system is activated.

6.1.2 Unit Production Testing (1/7/2012)

Valves intended to be used at a working temperature below -55°C are to be tested at the Manufacturer's plant in the presence of the Society's Surveyor.

Testing is to include a hydrostatic test of the valve body at a pressure equal to 1.5 times the design pressure, seat and stem leakage test at a pressure equal to 1.1 times the design pressure, as well as cryogenic testing consisting of valve operation and leakage verification for a minimum of 10% of each type and size of valve for valves intended to be used at a working temperature below -55°C.

As an alternative to the above, if so requested by the relevant Manufacturer, certification of a valve may be issued subject to the following:

- the valve has been approved as required by [3.1.1] for valves intended to be used at a working temperature below -55°C, and
- the Manufacturer has a recognised quality system that has been assessed and certified by the Society subject to periodical audits, and
- the quality control plan contains a provision to subject each valve to a hydrostatic test of the valve body at a pressure equal to 1.5 times the design pressure and seat and stem leakage test at a pressure equal to 1.1 times the design pressure. The Manufacturer is to maintain records of such tests, and
- cryogenic testing is performed, in the presence of the Society's representative, consisting of valve operation and leakage verification for a minimum of 10% of each type and size of valve for valves intended to be used at a working temperature below -55°C.

7 Emergency shutdown

7.1 Clarification on location of fusible elements

7.1.1 (1/7/2012)

The cargo stations in way of which the fusible elements mentioned in paragraph 5.6.4 of the IGC Code are to be fitted are to be intended as the loading and unloading manifolds.

8 Bonding

8.1 Static electricity

8.1.1 Acceptable resistance (1/7/2012)

To avoid the hazard of an incentive discharge due to the build-up of static electricity resulting from the flow of the liquid/gases/vapours, the resistance between any point on the surface of the cargo and slop tanks, piping systems and equipment, and the hull of the ship is not to be greater than $10^6 \Omega$.

8.1.2 Bonding straps (1/7/2012)

Bonding straps are required for cargo and slop tanks, piping systems and equipment which are not permanently connected to the hull of the ship, for example:

- a) independent cargo tanks
- b) cargo tank piping systems which are electrically separated from the hull of the ship
- c) pipe connections arranged for the removal of the spool pieces.

Where bonding straps are required, they are to be:

- a) clearly visible so that any shortcoming can be clearly detected
- b) designed and sited so that they are protected against mechanical damage and are not affected by high resistivity contamination, e.g. corrosive products or paint
- c) easy to install and replace.

SECTION 6

MATERIALS FOR CONSTRUCTION

1 General

1.1

1.1.1 (1/7/2012)

In general, the requirements of Part D apply. For particular cases, the acceptance of materials of construction will be considered by the Society on a case-by-case basis, taking into consideration the specific arrangements.

SECTION 7

OVERPRESSURE PROTECTION FOR CARGO CONTAINMENT AND PIPING SYSTEM

1 General

1.1

1.1.1 (1/7/2012)

Accident scenarios like fire and gas leak are to be subjected to risk assessment (refer to "Tasneef Guide for Risk Analysis" for guidance). In particular, it is strongly recommended to resort to consequence analysis (typically, gas dispersion, heat radiation, high-pressure leaks etc.) to support the design of protection systems, carried out by recognized methods and tools. The Society should be involved in the risk assessment activities early in the design process, and will retain the final documentation for information.

2 Cargo Tanks and piping

2.1 General

2.1.1 (1/7/2012)

In general, the requirements of IGC Code, 8.1 and 8.2 apply for pressure relieving systems.

Cargo tanks containing gas (i.e. fluid that remains in gaseous phases in all expected conditions of utilization) are not subjected to 8.2.2, 8.2.3, 8.2.16 and 8.2.17.

Tanks containing two-phase fluids (e.g. if liquid separation processes are fitted) are also to comply with the requirements of IGC Code 8.3, 8.2.3, 8.2.16 and 8.2.17.

Additional requirements are given in the following.

The pressure in the cargo tanks, after filling, is to be limited to 95% of the design pressure in any condition, including transportation.

- a) Every cargo tank is to be provided with safety systems to protect from overpressure. At least a purely mechanically-actuated safety valve of adequate capacity is to be fitted. A single failure of the safety system is not to hamper the overpressure protection of the cargo tank.
- b) Safety devices ensuring protection of pressure vessels in normal service are to be rated to operate before the pressure exceeds the maximum working pressure by more than 5%.
- c) Cargo tanks and associated piping are to be protected against low temperature effects arising from nearby high-pressure gas leaks.
- d) Cargo tanks and associated piping are to be protected against fire scenarios.
- e) Cargo holds are to be protected against overpressure and vacuum conditions, avoiding the ingress of air.

2.1.2 (1/7/2012)

In general, a venting system is to be provided, with the following characteristics:

- it is to ensure the possibility of relief from individual cargo tanks, or groups thereof, in case of leakage
- it is to be provided with remote control to vent individual cargo tanks, or groups thereof
- a detection system is to be fitted, to promptly detect leakages in individual cargo tanks, or groups thereof; the detection system is to follow the criteria laid down in Part C, Chapter 3 for automation systems intended for essential service
- the outlets of all venting systems are to be led to an area where heat radiation (for flares) or gases (for cold vents, relief valves etc.) does not cause hazard to the vessel, personnel and equipment
- if the cold venting option is selected, its size and height is to be supported by gas dispersion studies carried out by recognized methods and tools; as a minimum, the vent exits are to be arranged at a distance of at least 5 m from exhaust ducts and at least 10 m from intake ducts serving machinery spaces
- if the flare option is selected, its size, height and emitted radiation is to be supported by heat radiation studies in addition to gas dispersion.
- the failure to open of a single valve is not to hamper the overpressure protection of any item of the cargo system.
- vent piping are to be protected against cooldown due to Joule-Thomson effects
- it is to be designed to maintain its structural integrity in any operating and environmental condition of the ship.

Overpressure protection measures equivalent, in terms of safety and reliability, to venting systems may be considered by the Society on a case-by-case basis, if properly supported by risk assessment and other relevant studies carried out by recognized methods and tools.

3 Information to the Master

3.1 Requirements

3.1.1 (1/7/2012)

The requirements of IGC Code, 15.2 apply.

SECTION 8

ENVIRONMENTAL CONTROL

1 Precautions against fire

1.1

1.1.1 (1/7/2012)

IGC Code Ch 9, 9.4.1 applies, with the additional requirements provided in the following.

Precautions are to be taken to minimize the risk that static electricity generated by the inert gas system may become a source of ignition.

2 Environmental Control within Cargo Tanks and Cargo Piping Systems

2.1 General

2.1.1 (1/7/2012)

A piping system is to be provided to enable each cargo hold to be safely gas-freed or purged. The system is to be arranged to minimize the possibility of pockets of gas or air remaining after gas-freeing or purging.

2.1.2 (1/7/2012)

Gas sampling connections at the inlet and outlet above the main deck are to be provided for each cargo hold in order to adequately monitor the progress of purging and gas-freeing.

2.1.3 (1/7/2012)

The system is to be arranged to minimize the possibility of a flammable mixture existing in the cargo hold during any part of the gas-freeing operation by utilizing an inerting medium as an intermediate step.

2.1.4 (1/7/2012)

Piping systems which may contain cargo are to be capable of being gas-freed and purged, as provided in [2.1.1] and [2.1.3].

2.1.5 (1/7/2012)

Inert gas utilized in these procedures may be provided from the shore or from the ship.

3 Environmental Control within the Hold Spaces for Cargo Tanks

3.1 General

3.1.1 (1/7/2012)

Hold spaces associated with cargo containment systems are to be inerted with a suitable dry inert gas and kept inerted with make-up gas provided by a shipboard inert gas generation system or by shipboard storage, which is to be sufficient for normal consumption for at least 30 days.

4 Inerting

4.1

4.1.1 (1/7/2012)

IGC Code 9.4.1 to 9.4.5 applies.

5 Inert gas production on board

5.1 Exemptions

5.1.1 (1/7/2012)

Inert gas generating systems are to be considered as essential services and are to comply with the applicable Sections of the Rules.

Where, in addition to inert gas produced on board, it is possible to introduce inert gas from a supply existing on board, it is not necessary that standby or spare components for the inert gas system are kept on board.

SECTION 9

ELECTRICAL INSTALLATIONS

1 General

1.1 Application

1.1.1 (1/7/2012)

The requirements in this Section apply, in addition to those contained in Part C, Chapter 2, to ships with the service notation Compressed natural Gas carriers. If the ship is gas-fuelled, Pt C, Ch 1, App 7 applies.

1.2 Documentation to be submitted

1.2.1 (1/7/2012)

In addition to the documentation requested in Pt C, Ch 2, Sec 1, Tab 1, the following are to be submitted for approval:

- a) plan of hazardous areas
- b) document giving details of types of cables and safety characteristics of the equipment installed in hazardous areas
- c) diagrams of tank level indicator systems, high level alarm systems and overflow control systems where requested.

1.3 System of supply

1.3.1 (1/7/2012)

Earthed systems with hull return are not permitted, with the following exceptions to the satisfaction of the Society:

- a) impressed current cathodic protective systems
- b) limited and locally earthed systems, such as starting and ignition systems of internal combustion engines, provided that any possible resulting current does not flow directly through any hazardous area
- c) insulation level monitoring devices, provided that the circulation current of the device does not exceed 30 mA under the most unfavourable conditions
- d) intrinsically safe systems.

1.3.2 (1/7/2012)

In insulated distribution systems, no current carrying part is to be earthed, other than:

- a) through an insulation level monitoring device
- b) through components used for the suppression of interference in radio circuits.

1.3.3 (1/7/2012)

The additional limitations in the choice of the system of supply (type of distribution system) as per SOLAS Ch.II-1 Reg. 45.4.3 apply.

1.4 Earth detection

1.4.1 (1/7/2012)

For both insulated and earthed distribution systems a device, or devices, are to be installed to continuously monitor the insulation to earth and to give an audible and visual alarm at a manned position in the event of an abnormally low level of insulation resistance and/or high level of leakage current.

The above is not applicable to systems mentioned in [1.3.1].

1.5 Precautions against inlet of gases or vapours

1.5.1 (1/7/2012)

Suitable arrangements are to be provided, to the satisfaction of the Society, so as to prevent the possibility of gases or vapours passing from a gas-dangerous space to another space through runs of cables or their conduits.

1.6 Electrical equipment permitted in hazardous areas

1.6.1 (1/7/2012)

Electrical equipment permitted in hazardous areas is that indicated in Pt C, Ch 2, Sec 3, [10.1.4], Pt C, Ch 2, Sec 3, [10.1.5][and Pt C, Ch 2, Sec 3, [10.1.6].

1.6.2 (1/7/2012)

In addition to the requirements of [1.6.1], in Zone 1 and Zone 2 the installation of the following is permitted: hull fittings containing the terminals or shell plating penetrations for anodes or electrodes of an impressed current cathodic protection system, or transducers such as those for depth sounding or log systems, provided that such fittings are of gas-tight construction or housed within a gas-tight enclosure, and are not located adjacent to a cargo tank bulkhead. The design of such fittings or their enclosures and the means by which cables enter, as well as any testing to establish their gas-tightness, are to be to the satisfaction of the Society. The associated cables are to be protected by means of heavy gauge steel pipes with gas-tight joints.

1.6.3 (1/7/2012)

Enclosed or semi-enclosed spaces (not containing a source of hazard) having a direct opening, including those for ventilation, into any hazardous area, are to be designated as the same hazardous zone as the area in which the opening is located.

Electrical installations are to comply with the requirements for the space or area into which the opening leads.

Note 1: For openings, access and ventilation conditions affecting the extent of hazardous areas, see IEC Standard 60092-502.

2 Hazardous locations

2.1 Hazardous area classification

2.1.1 (1/7/2012)

The extension of the gas dangerous zones in this section is given for guidance only. It is to be confirmed by risk assessment, taking into account high pressure relief sources and onboard equipment.

2.1.2 (1/7/2012)

For hazardous area classification see Tab 1. Risk assessment activities, in particular the gas dispersion studies, are to

confirm the adequacy of such classification or provide additional or different criteria.

3 Product classification

3.1 Temperature class and explosion group

3.1.1 (1/7/2012)

Tab 2 specifies temperature class and explosion group data for the products eligible to be carried by CNG ships.

Table 1 : Classification of hazardous areas for CNG ships (1/7/2012)

Spaces		Hazardous area
No.	Description	
1	Cargo containment systems	Zone 0
2	Hold spaces where cargo is carried in a cargo containment system	Zone 1
3	Cargo pump (for liquid phase, if any) and cargo compressor rooms	Zone 1
4	Areas on open deck, or semi-enclosed spaces on open deck, within 3 m of any cargo tank outlet, gas or vapour outlet, cargo manifold valve, cargo valve, cargo pipe flange, cargo pump and cargo compressor room ventilation outlets	Zone 1
5	Areas on open deck, or semi-enclosed spaces on open deck above and in the vicinity of any cargo gas outlet intended for the passage of large volumes of gas or vapour mixture during cargo loading and ballasting or during discharging, within a vertical cylinder of unlimited height and 6 m radius centred upon the centre of the outlet, and within a hemisphere of 6 m radius below the outlet	Zone 1
6	Areas on open deck, or semi-enclosed spaces on open deck, within 1.5 m of cargo pump and cargo compressor room entrance, cargo pump and cargo compressor room ventilation inlet, openings into cofferdams or other zone 1 spaces	Zone 1
7	Areas on open deck over all cargo holds (including ballast tanks within the cargo hold area) where structure restricts natural ventilation and to the full breadth of the ship plus 3 m fore and aft of the forward-most and aft-most cargo tank bulkhead, up to a height of 2.4 m above the deck	Zone 1
8	Compartment for cargo hoses and equipment	Zone 1
9	Enclosed or semi-enclosed spaces in which pipes containing cargoes are located	Zone 1
10	Enclosed or semi-enclosed spaces in which pipes containing cargo products for boil-off gas fuel burning systems are located, unless special precautions approved by the Society are provided to prevent product gas escaping into such spaces	Zone 1
11	Areas of 1,5 m surrounding open or semi-enclosed spaces of Zone 1	Zone 2
12	Areas 4 m beyond the cylinder and 4 m beyond the sphere defined in item 5	Zone 2
13	Spaces forming an air-lock	Zone 2
14	Areas on open deck over all cargo holds (including all ballast tanks within the cargo holds or tank area) where unrestricted natural ventilation is guaranteed and to the full breadth of the ship plus 3 m fore and aft of the forward-most and aft-most cargo tank bulkhead, up to a height of 2.4 m above the deck surrounding open or semi-enclosed spaces of Zone 1	Zone 2

Spaces		Hazardous area
No.	Description	
15	Spaces forward of the open deck areas to which reference is made in item 10 and item 18, below the level of the main deck, and having an opening on the main deck or at a level less than 0,5 m above the main deck, unless: <ul style="list-style-type: none"> a) the entrances to such spaces do not face the cargo tank area and, together with all other openings to the spaces, including ventilation system inlets and exhausts, are situated at least 5 m from the foremost cargo tank and at least 10 m measured horizontally from any cargo tank outlet or gas or vapour outlet; and b) the spaces are mechanically ventilated 	Zone 2
16	Areas within 2,4 m of the outer surface of a cargo tank where such surface is exposed to the weather	Zone 2

Table 2 : Temperature class and explosion group of certain products (1/7/2012)

Product name	Temperature class	Explosion group
Butadiene	T2	II B
Butane	T2	II A
Butane/propane mixture	T2	II A
Butylenes	T3	II A
Ethane	T2	II A
Methane	T1	II A
Nitrogen	NF	NF
Propane	T2	II A
Propylene	T2	II B

SECTION 10

FIRE PROTECTION AND FIRE EXTINCTION

1 Application

1.1 General

1.1.1 (1/7/2012)

The requirements of this Section are not applicable for the purpose of classification, except where the Society carries out surveys relevant to fire protection statutory requirements on behalf of the Flag Administration. In such cases, unless otherwise provided by the Flag Administration, fire protection statutory requirements as contained in this Section are considered a matter of Class and their compliance is verified by the Society for classification purposes.

1.1.2 (1/7/2012)

The ship is to comply with SOLAS Ch II-2 and IGC Code as far as applicable, irrespective of tonnage, including ships of less than 500 tons gross tonnage. The cargo area is to comply with the additional requirements specified in this Section. If the ship is gas-fuelled, Pt C, Ch 1, App 7 applies. Risk Assessment activities are in any case mandatory, (in particular, consequence analysis of fire scenarios), which are expected to originate further, more specific criteria for passive and active fire protection.

2 Additional criteria

2.1 Structural fire protection

2.1.1 (1/7/2012)

If a process system with gas under high pressure, or any other potential source of gas release, is placed on the weather deck in way of the cargo holds, deck cargo system, accommodation and other essential areas or equipment which may be exposed to heat loads, additional means of protection are to be considered against events resulting from risk assessment studies. Examples of such events are jet fire and impingement of low temperature gas due to Joule-Thomson expansion effects.

In particular, cargo piping is to run in inerted ducts with means of detection of gas leakage, or is to be arranged in such a way as to provide an equivalent safety level.

2.1.2 (1/7/2012)

Hold spaces are to have the following characteristics:

- resistance to fire load in scenarios ascertained by risk assessment studies, taking into account the heat resistance properties of cargo tanks materials
- sufficient strength and tightness to ensure effective inert atmosphere within hold spaces during both normal and abnormal conditions as ascertained by risk assessment studies.

2.1.3 (1/7/2012)

Process area and cargo holds are to be separated from accommodations, service spaces and engine room below

the weather deck by means of cofferdams, having minimum distance between the bulkheads of 600 mm.

3 Means of escape

3.1

3.1.1 (1/7/2012)

Escape routes are to enable the crew to safely reach the assembly stations from any location during accident scenarios peculiar to CNG ships, e.g. the gas release and the heat radiation due to hydrocarbon fires. For this purpose, such routes are to be sheltered from cargo and process areas. Further criteria, such as the degree of protection from heat radiation of the escape routes and of the life-saving appliances, are expected to stem from risk assessment activities.

4 Fire Extinction

4.1

4.1.1 (1/7/2012)

The primary means of extinction of fires consequent to gas escape is the isolation of the leak by means of the ESD system.

4.1.2 (1/7/2012)

The fire fighting systems, in addition to SOLAS Ch II-2 are to comply with the following minimum requirements and criteria, which are to be integrated by the results of the risk assessment.

- a) The fire fighting system is to be specially sized to cool down the areas and the systems of the CNG ship containing pressurized gas, and the structures of manned areas and fire hazardous spaces which may be engulfed by hydrocarbon fires.
- b) The following items are typically to be protected by water spray:
 - 1) weather deck in way of cargo holds, and any exposed parts of cargo tanks;
 - 2) on-deck process systems;
 - 3) cargo discharge and loading manifolds with all the control, relief and isolation valves;
 - 4) ESD system
 - 5) boundaries of superstructures and deckhouses normally manned, cargo compressor rooms, cargo pump rooms, flare mast, storerooms containing high fire risk items and cargo control rooms, all facing the cargo area.
- c) The arrangement is to be such that at least two jets of water can reach any part of the weather deck in way of the cargo holds and any part of the process and safety systems on deck and above. For this purpose, the capac-

ity of fire pumps, fire mains and water service pipe diameters is not to be limited by requirements of SOLAS Ch II-2, Reg. 10.2.2.4.1 and 10.2.1.3. In particular, each fire pump is to have 100% capacity. Additional capacity is required if the main fire pumps are also used to supply water spray with the characteristics above indicated. In any case, a connection system with an isolating valve is to be provided between the water spray system and the water mains in a protected area, easily accessible by operators.

- d) One pump is to be located forward of the cargo area and one pump aft of the cargo area and both pumps are to be arranged with remote control from both the bridge and the engine room. Both main fire pumps are to be available at any time for start and delivery of water during operation. The fire pumps shall start automatically upon low pressure detection in the fire mains. The remote operation of fire pumps and valves is to be possible from suitable locations protected by fire and gas, outside the cargo areas.
- e) The number and position of hydrants is to be such that at least two jets of water not emanating from the same hydrant, one of which is to be from a single length of hose, may reach any part of the weather deck in way of the cargo holds and any part of the process and safety systems on deck and above.
- f) Considerations are to be given to the layout of the fire mains, to protect it from the possibility of jet fire impingement.

SECTION 11

MECHANICAL VENTILATION IN THE CARGO AREA

1 General

1.1 Safety

1.1.1 (1/7/2012)

The ventilation system is to discharge to outlets ensuring safe environment for crew during release of inert gas.

1.2 Shutdown philosophy

1.2.1 (1/7/2012)

Shut down philosophy for gas detection in cargo area, air ventilation intakes for accommodation and machinery spaces shall be evaluated.

2 Spaces required to be entered during normal cargo handling operations

2.1 Location of discharges from dangerous spaces

2.1.1 Ventilation duct arrangement (1/7/2012)

The ventilation duct arrangement is to comply with the applicable requirements of IGC Code, 12.1.1 to 12.1.6 .

- a) Ventilation ducts are to be arranged at a suitable height from the weather deck. This height is not to be less than 2,4 m for intake ducts.
- b) Ventilation ducts are to be fitted with metallic fire dampers provided with "open" and "closed" signs. These dampers are to be arranged in the open, in a readily accessible position.

2.2 Recirculation prevention

2.2.1 (1/7/2012)

The requirements of IGC Code, 12.1.7 and 12.1.8 apply.

2.3 Non-sparking fans

2.3.1 (1/7/2012)

IGC Code, 12.1.9 to 12.1.11 apply, with the following additional requirements.

- a) A fan is considered as non-sparking if in both normal or abnormal conditions it is unlikely to produce sparks.
- b) The air gap between the impeller and the casing is to be not less than 0,1 of the shaft diameter in way of the

impeller bearing and not less than 2 mm. It need not be more than 13 mm.

2.3.2 Materials (1/7/2012)

- a) The impeller and the housing in way of the impeller are to be made of alloys which are recognised as being spark proof by appropriate tests.
- b) Electrostatic charges both in the rotating body and the casing are to be prevented by the use of antistatic materials. Furthermore, the installation on board of the ventilation units is to be such as to ensure their safe bonding to the hull.
- c) Tests may not be required for fans having the following combinations:
 - impellers and/or housings of non-metallic material, due regard being paid to the elimination of static electricity
 - impellers and housings of non-ferrous materials
 - impellers of aluminium alloys or magnesium alloys and a ferrous (including austenitic stainless steel) housing on which a ring of suitable thickness of non-ferrous materials is fitted in way of the impeller
 - any combination of ferrous (including austenitic stainless steel) impellers and housings with not less than 13 mm design tip clearance.
- d) The following impellers and housings are considered as sparking and are not permitted:
 - impellers of an aluminium alloy or magnesium alloy and a ferrous housing, regardless of tip clearance
 - housing made of an aluminium alloy or a magnesium alloy and a ferrous impeller, regardless of tip clearance
 - any combination of ferrous impeller and housing with less than 13 mm design tip clearance.

2.3.3 Type test for non-sparking fans (1/7/2012)

Type tests on the finished product are to be carried out in accordance with the requirements of the Society or an equivalent national or international standard.

2.3.4 Motor shafting (1/7/2012)

The shafting penetration of motors driving fans through bulkheads and decks of dangerous spaces or through ventilation ducts is to be fitted with a gas-tight sealing device, of the oil-seal type or equivalent, deemed suitable by the Society.

3 Spaces not normally entered

3.1 General requirements

3.1.1 Minimum number of air changes (1/7/2012)

IGC Code, 12.2 applies, with the following additional requirements.

Both fixed and portable systems are to guarantee the efficient ventilation of such spaces in relation to the relative

density, in respect of the air, and to the toxicity of the gases transported. Such ventilation system is to be capable of effecting not less than 8 air changes per hour. The type of portable fans and their connection to the spaces served are to be approved by the Society. In no case are portable electrical fans acceptable.

SECTION 12

INSTRUMENTATION (GAUGING, GAS DETECTION)

1 General

1.1

1.1.1 (1/7/2012)

If the ship is gas-fuelled, Pt C, Ch 1, App 7 applies.

1.2 Cargo tank instrumentation

1.2.1 (1/7/2012)

The instrumentation is to be of a type approved by the Society.

1.3 Drainage

1.3.1 (1/7/2012)

Hold spaces are to be provided with a suitable drainage arrangement not connected with machinery spaces. Means for detecting leakage of water into the hold space are to be provided.

1.4 Indicator location

1.4.1 Monitoring list (1/7/2012)

IGC Code, 13.1.3 applies, with the following additional requirements.

The following information and alarms are to be concentrated in the positions specified in this paragraph.

- a) The following is to be located in the "cargo control room" and the "control stations" defined in 1.3 of the IGC Code :
 - 1) indication signalling the presence of water in holds or interbarrier spaces
 - 2) cargo heater (if fitted) low temperature alarm
 - 3) indication of the pressure with appropriate high pressure alarm in each cargo tank and in each hold space gas detection equipment alarm required in 13.6.4 of the IGC Code
 - 4) cargo compressor high temperature alarm
 - 5) the alarm for automatic shutdown of the cargo compressor for high pressure or high temperature
 - 6) **Indication of temperature and oxygen of each hold space**
 - 7) Monitoring of the temperature in the appropriate locations during pressure relief situations such as unloading or vent, to ensure that the temperature does not decrease below the minimum design temperature
 - 8) Detection of moisture and H₂S at the load/unload or shore connection.

When the cargo system is not remote controlled and therefore the aforesaid "control positions" are not required, the above-mentioned controls, information and alarms are to be located in a suitable, easily accessible location.

If this position is an enclosed space, it is to comply with the requirements of 13.6.7 of the IGC Code.

- b) Independently of the above, the following is to be transduced to the wheelhouse:
 - 1) the alarm signalling the presence of water in cargo holds
 - 2) the cargo heater (if fitted) low temperature alarm.

1.4.2 Indication of the pressure value in each cargo tank (1/7/2012)

Such indication is to give the setting pressure value of the relief valve and the maximum allowable pressure value in the cargo tank concerned. The audible and visual alarms for cargo tanks are to be located in such a position as to be clearly heard and identifiable by the personnel in charge of loading operation control.

1.4.3 Temperatures of the heating circuits (1/7/2012)

The temperatures of the heating circuits, if fitted to prevent hydrate formation or to prevent Joule-Thomson effects, are to be monitored, and low and high temperature alarms are to be provided, as appropriate.

2 Gas detection requirements

2.1

2.1.1 (1/7/2012)

In addition to the applicable requirements of IGC Code, 13.6, the following requirements are to be complied with.

2.2 Gas Measurements

2.2.1 (1/7/2012)

In addition to the provisions of [2.2] to [2.3], the fitting of gas measuring equipment is subject to those of Pt C, Ch 4, Sec 1, [5.2.4] b). An independent gas detection system is to be installed on the deck cargo area to monitor the presence of leaks, and activate the ESD in case of leak detection. As a minimum, the presence of gas is to be checked in the following spaces:

- a) every hold space
- b) deck piping
- c) ventilation inlets/outlets for gas dangerous spaces
- d) air inlets to machinery spaces
- e) manifold area.

2.3 Position of sampling heads

2.3.1 (1/7/2012)

In addition to the requirements of IGC Code 13.6.5, gas sampling lines are to be located outside accommodation spaces, unless they are fitted within gas-tight pipes.

3 Protected spaces

3.1

3.1.1 (1/7/2012)

In addition to the list in paragraph 13.6.7 of the IGC Code, the gas detection system is also to serve spaces adjacent to pump rooms and compressor rooms.

4 Portable gas detectors

4.1

4.1.1 (1/7/2012)

Every ship is to be provided with at least two sets of portable gas detection equipment acceptable to the Administration and suitable for the product to be carried.

If it is expected that the gases to be carried are both toxic and flammable, two sets for toxic gases and two sets for flammable gases are to be provided.

SECTION 13

USE OF CARGO AS FUEL

1 Application

1.1 General

1.1.1 (1/7/2012)

In general, Pt C, Ch 1, App 7 applies.

1.1.2 (1/7/2012)

Further requirements are as follows.

- a) Gas used for fuel is to be purified from entrained liquids and substances that may damage the users, according to the manufacturers' requirements.
- b) Gas containing H₂S is to be sweetened if it is conveyed to enclosed machinery spaces, which are to be equipped with H₂S gas detectors set to give an alarm at

10 ppm and to activate the shut-off of the master gas valve at 50 ppm.

- c) If gas-fired equipment is located in enclosed spaces on the cargo deck, such spaces are to have ventilation system providing at least 30 air changes per hour. These spaces are to be fitted with gas detection system to give an alarm at 20% LEL and to activate the shut-off of the master gas valve at 60% LEL.

1.2 Testing

1.2.1 (1/7/2012)

Piping, valves and fittings are to be hydrostatically tested, after assembly onboard, to 1.5 times the working pressure. Subsequently, they are to be pneumatically tested to ascertain that all the joints are perfectly tight.

SECTION 14**SPECIAL REQUIREMENTS****1 Materials for construction****1.1****1.1.1** (1/7/2012)

IGC Code 17.2.2 applies.

Materials "exposed to cargo" are those constituting systems, cargo appliances or arrangements which are in contact with cargo gas or vapor in normal operating conditions.

2 Independent tanks**2.1****2.1.1** (1/7/2012)

The gas is to be carried in independent pressure vessels only.

3 Deck cargo piping**3.1****3.1.1** (1/7/2012)

One hundred per cent radiography of all butt-welded joints in cargo piping is required, irrespective of the diameter.

4 Exclusion of air from vapor spaces**4.1****4.1.1** (1/7/2012)

Air is to be removed from the cargo tanks and associated piping before loading and then subsequently excluded by introducing inert gas.

5 Moisture control**5.1****5.1.1** (1/7/2012)

Moisture control is to be provided to ensure that cargo tanks are dry at all times.

6 Permanently installed toxic gas detectors**6.1****6.1.1** (1/7/2012)

IGC Code 17.9 applies.

7 Flame screens on vent outlets**7.1****7.1.1** (1/7/2012)

IGC Code 17.10 applies.

SECTION 15**ADDITIONAL INFORMATIONS ON PRODUCTS****1 General**

to be taken into account for the design of a ship might be altered considering the actual properties of the commercial product.

1.1**1.1.1 (1/7/2012)**

The list shown in Tab 1 gives properties for pure products, expected to be carried on CNG carriers. The specific gravity

Information on temperature classes and explosion groups for electrical equipment in connection with the products to be carried is indicated in Sec 9, Tab 2.

Table 1 (1/7/2012)

Product name	Boiling temperature (°C)	Specific gravity at boiling point (kg/m ³)	Ratio vapour/air density
Butadiene	- 4,5	650	1,87
Butane	-0,5/11,7	600	2,02
Butylenes	- 6,3/- 7	625	1,94
Ethane	- 88,6	549	1,04
Ethylene	- 104	570	0,97
Ethylene oxide	-10,7	870	1,52
Nitrogen	-196	808	0,97
Pentanes (all isomers)	36,1	610	2,6
Pentene (all isomers)	30,1/37	610	2,6
Propane	-42,3	580	1,56
Propylene	-47,7	610	1,50

OIL CARRIERS - ASSISTED PROPULSION

- SECTION 1 GENERAL**
- SECTION 2 SHIP ARRANGEMENT**
- SECTION 3 STABILITY**
- SECTION 4 MACHINERY AND CARGO SYSTEMS**
- SECTION 5 MACHINERY AND CARGO SYSTEMS FOR OIL CARRIER,
FLASHPOINT > 60°C**
- SECTION 6 ELECTRICAL INSTALLATIONS**

SECTION 1

GENERAL

1 General

1.1 Application

1.1.1 Service notation oil carrier (1/5/2013)

- a) The requirements of this Chapter apply to ships having the service notations oil tanker, as defined in Pt A, Ch 1, Sec 2, [4.5.2]

As indicated in Pt A, Ch 1, Sec 2, [4.5.11] these units are to be assigned with the additional service feature **assisted propulsion**.

Note 1: As recalled in Part A, Chapter 1, Sec 1, [3.1.1], the classification of a ship does not absolve the Interested Party from compliance with any requirements issued by Administrations and any other applicable international and national regulations for the safety of life at sea and protection of the marine environment.

- b) Departures are given for oil carriers that have the additional service feature **oil carriers, flashpoint > 60°C** and are intended only for the carriage of bulk cargoes:
- at a temperature below and not within 15°C of their flashpoint, or
 - having a flashpoint above 100°C.
- c) The list of substances the carriage in bulk of which is covered by the service notations
- **oil carrier**
 - **oil carrier, flashpoint > 60°C**
is the one in MARPOL 73/78 annex Convention, except "naphta solvent", the carriage of which is subject to compliance with Chapter 8.

1.2 Summary tables

1.2.1 (1/5/2013)

Tab 1 indicates, for easy reference, the Sections or Appendixes of this Chapter dealing with requirements applicable to ships having the following service notations:

- **oil carrier**
- **oil carrier, flashpoint > 60°C.**

1.3 Definitions

1.3.1 Cargo area (1/5/2013)

The cargo area is that part of the ship that contains cargo tanks as well as slop tanks, cargo pump rooms including pump rooms, cofferdams, ballast or void spaces adjacent to cargo tanks or slop tanks as well as deck areas throughout the entire length and breadth of the part of the ship above these spaces.

When independent tanks are installed in hold spaces, the cofferdams, ballast or void spaces at the after end of the aftermost hold space or at the forward end of the forwardmost hold space are excluded from the cargo area.

Table 1 : Sections or Appendixes with requirements applicable to ships having the Service Notations indicated in [1.2.1] (1/5/2013)

Main subject	Reference
Ship arrangement	Sec 2
Hull and stability	Sec 3
Machinery and cargo system	Sec 4 and Sec 5
Electrical installations	Sec 6
Automation	(1)
Fire protection, detection and extinction	(1)
Devices to prevent the passage of flames into cargo tanks	Ch 7, App 1
Crude oil washing system	Ch 7, App 2
(1) No specific requirements are given in this Chapter.	

1.3.2 Cargo pump room (1/5/2013)

Cargo pump room is a space containing pumps and their accessories for the handling of products covered by the service notation granted to the ship.

1.3.3 Cargo service spaces (1/5/2013)

Cargo service spaces are spaces within the cargo area used for workshops, lockers and storerooms of more than 2 m² in area, intended for cargo handling equipment.

1.3.4 Clean ballast (1/5/2013)

Clean ballast means the ballast in a tank which since oil was last carried therein, has been so cleaned that the effluent therefrom if it were discharged from a ship which is stationary into clean calm water on a clear day would not produce visible traces of oil on the surface of the water or on adjoining shorelines or cause a sludge or emulsion to be deposited beneath the surface of the water or upon adjoining shorelines. If the ballast is discharged through an oil discharge monitoring and control system approved by the Society, evidence based on such a system to the effect that the oil content of the effluent did not exceed 15 parts per million is to be determinative that the ballast was clean, notwithstanding the presence of visible traces.

1.3.5 Crude oil (1/5/2013)

Crude oil means any liquid hydrocarbon mixture occurring naturally in the earth whether or not treated to render it suitable for transportation and includes:

- a) crude oil from which certain distillate fractions have been removed, and
- b) crude oil to which certain distillate fractions may have been added.

1.3.6 Crude oil carrier (1/5/2013)

Crude oil carrier means an oil carrier engaged in the trade of carrying crude oil.

1.3.7 Hold space (1/5/2013)

Hold space is the space enclosed by the ship's structure in which an independent cargo tank is fitted

1.3.8 Fuel oil (1/5/2013)

Fuel oil means any oil used as fuel in connection with the propulsion and auxiliary machinery of the ship on which such oil is carried.

1.3.9 Integrated cargo and ballast system (1/5/2013)

Integrated cargo and ballast system means any integrated hydraulic and/or electric system used to drive both cargo and ballast pumps (including active control and safety systems and excluding passive components, e.g. piping).

1.3.10 Oil mixture (1/5/2013)

Oil mixture means a mixture with any oil content.

1.3.11 Product carrier (1/5/2013)

Product carrier means an oil carrier engaged in the trade of carrying oil other than crude oil.

1.3.12 Pump room (1/5/2013)

Pump room is a space, located in the cargo area, containing pumps and their accessories for the handling of ballast and fuel oil, or cargoes other than those covered by the service notation granted to the ship.

1.3.13 Segregated ballast (1/5/2013)

Segregated ballast means the ballast water introduced into a tank which is completely separated from the cargo oil and fuel oil system and which is permanently allocated to the carriage of ballast or to the carriage of ballast or cargoes other than oil or noxious substances as variously defined in Chapter 7 or Chapter 8.

1.3.14 Slop tank (1/5/2013)

Slop tank means a tank specifically designated for the collection of tank draining, tank washings and other oily mixtures.

1.3.15 Void space (1/5/2013)

Void space is an enclosed space in the cargo area external to a cargo tank, except for a hold space, ballast space, fuel oil tank, cargo pump room, pump room, or any space normally used by personnel.

SECTION 2

SHIP ARRANGEMENT

1 General

1.1 Application

1.1.1 (1/5/2013)

The requirements in Sec 2 apply to single deck ships, integral cargo tanks with machinery aft, double bottom throughout the cargo tank area, double side skin and possible longitudinal bulkheads, or single side skin and one or more longitudinal bulkheads throughout the cargo tank area. The deck may be single or double skin, with or without a trunk.

The application of these requirements to other ship types is to be considered by the Society on a case-by-case basis.

1.1.2 Deviations (1/5/2013)

The requirements in [2.1.2] and [2.1.3], apply only to ships with the service notations:

- oil carrier.

The requirements in [2.2], [3] and [4], apply only to ships with the service notations:

- oil carrier
- oil carrier, flashpoint > 60°C.

1.1.3 Exemptions (1/5/2013)

The requirements in Pt B, Ch 2, Sec 2, [3] b) and [5] do not apply.

2 General arrangement design

2.1 General

2.1.1 Cofferdams (1/5/2013)

A cofferdam or similar compartment of width not less than 760 mm is to be provided at the aft end of the cargo tank area. Its bulkheads are to extend from keel to deck across the full breadth of the ship.

For the purpose of this requirement, the term “cofferdam” is intended to mean an isolating compartment between two adjacent steel bulkheads or decks. The minimum distance between the two bulkheads or decks is to be sufficient for safe access and inspection.

In order to meet the single failure principle, in the particular case when a corner-to-corner situation occurs, this principle may be met by welding a diagonal plate across the corner.

The cofferdams are also to be constructed so as to enable adequate ventilation.

2.1.2 Cargo segregation (1/5/2013)

Unless expressly provided otherwise, in ships enabled to carry cargoes having a flashpoint below 60°C, tanks containing cargo or cargo residues are to be placed forward of and segregated from accommodation, service and machinery spaces, drinking water and stores for human consumption by means of a cofferdam, or any other similar compartment and arranged in such a way that a single failure of a deck or bulkhead will not permit the entry of gas or vapour from the cargo tank into control stations, accommodation and service spaces (see Fig 1 and Fig 2).

Figure 1 (1/5/2013)

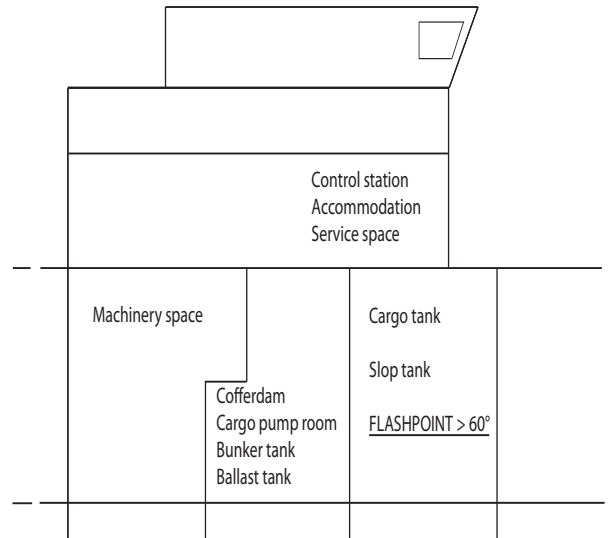
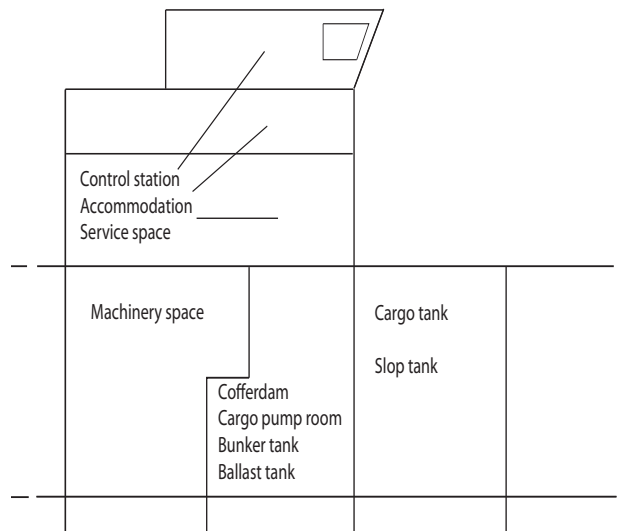

Figure 2 (1/5/2013)



2.1.3 Deck spills (1/5/2013)

Means are to be provided to keep deck spills away from the accommodation and service areas. This may be accomplished by providing a permanent continuous coaming of a suitable height extending from side to side.

Where gutter bars are installed on the weather decks of oil carriers in way of cargo manifolds and are extended aft as far as the aft bulkhead of superstructures for the purpose of containing cargo spills on deck during loading and discharge operations, the free surface effects caused by containment of a cargo spill during liquid transfer operations or of boarding seas while underway are to be considered with respect to the vessel's available margin of positive initial stability (GM_0).

Where the gutter bars installed are higher than 300 mm, they are to be treated as bulwarks with freeing ports arranged in accordance with Pt B, Ch 9, Sec 9, [5] and effective closures provided for use during loading and discharge operations. Attached closures are to be arranged in such a way that jamming cannot occur while at sea, ensuring that the freeing ports will remain fully effective.

On ships without deck camber, or where the height of the installed gutter bars exceeds the camber, and for oil carriers having cargo tanks exceeding 60% of the vessel's maximum

beam amidships regardless of gutter bar height, gutter bars may not be accepted without an assessment of the initial stability (GM_0) for compliance with the relevant intact stability requirements taking into account the free surface effect caused by liquids contained by the gutter bars.

2.2 Double bottom tanks or compartments

2.2.1 General (1/5/2013)

Double bottom tanks adjacent to cargo tanks may not be used as fuel oil tanks.

2.2.2 Oil carriers of 5000 t deadweight and above (1/5/2013)

At any cross-section, the depth of each double bottom tank or compartment is to be such that the distance h between the bottom of the cargo tanks and the moulded line of the bottom shell plating measured at right angles to the bottom shell is not less than $B/15$, in m, with a minimum value of 0,76 m.

In the turn of the bilge area and at locations without a clearly defined turn of the bilge, the cargo tank boundary line is to run parallel to the line of the midship flat bottom as shown in Fig 3.

Figure 3 : Cargo tank boundary lines (1/5/2013)

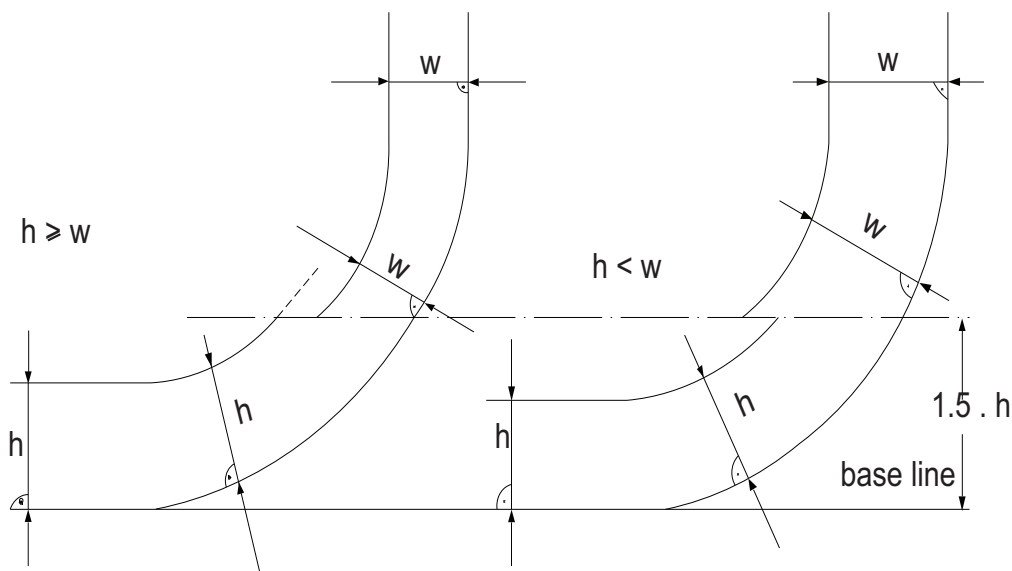
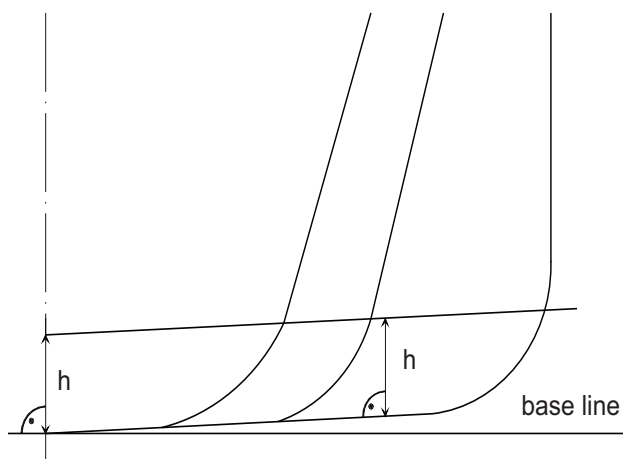

Figure 4 : Cargo tank boundary lines (1/5/2013)

2.3 Navigation position

2.3.1 (1/5/2013)

When it is proven necessary to provide a navigation station above the cargo area, such station is to be for navigation purposes only and is to be separated from the cargo tank deck by an open space of at least 2 m in height.

3 Size and arrangement of cargo tanks and slop tanks

3.1 Cargo tanks

3.1.1 General (1/5/2013)

Oil carriers of 600 t deadweight and above are not allowed to carry oil in any compartment extending forward of a collision bulkhead located in accordance with Pt B, Ch 2, Sec 1, [2].

3.1.2 Size of cargo tanks (1/5/2013)

The length of each cargo tank is not to exceed 10 metres or one of the values of Tab 1, as applicable, whichever is the greater.

Oil carriers are to be provided with cargo tanks so arranged that the capacity of each cargo tank does not exceed 700 m³ unless wing tanks or compartments are arranged, extending either for the full depth of the ship side or from the top of the double bottom to the uppermost deck, disregarding a rounded gunwale where fitted. They are to be arranged such that the cargo tanks are located inboard of the moulded line of the side shell plating, nowhere less than the distance w which, as shown in Fig 4, is measured at any cross-section at right angles to the side shell, as specified below:

$$w = 0,4 + \frac{2,4DW}{20000} \text{ with a minimum value of } 0,76 \text{ m}$$

DW is the deadweight, in t.

3.1.3 Piping through cargo tanks (1/5/2013)

Lines of piping which run through cargo tanks in a position less than $0,30 B_s$ from the ship's side or less than $0,30 D_s$

from the ship's bottom are to be fitted with valves or similar closing devices at the point at which they open into any cargo tank. These valves are to be kept closed at sea at any time when the tanks contain cargo oil, except that they may be opened only for cargo transfer needed for essential operations.

3.1.4 Suction wells in cargo tanks (1/5/2013)

Suction wells in cargo tanks may protrude into the double bottom below the boundary line defined by the distance h in [2.2.2] or, as applicable, provided that such wells are as small as practicable and the distance between the well bottom and bottom shell plating is not less than $0,5 h$.

3.2 Slop tanks

3.2.1 Oil carriers of 150 gross tonnage and above (1/5/2013)

The arrangements of the slop tank or combination of slop tanks are to have a capacity necessary to retain the slop generated by tank washings, oil residues and dirty ballast residues. The total capacity of the slop tank or tanks is to be not less than 3 per cent of the oil carrying capacity of the ships, except that the Society may accept:

- 2% for such oil carriers where the tank washing arrangements are such that once the slop tank or tanks are charged with washing water, this water is sufficient for tank washing and, where applicable, for providing the driving fluid for ejectors, without the introduction of additional water into the system
- 2% where segregated ballast tanks are provided. This capacity may be further reduced to 1,5% for such oil carriers where the tank washing arrangements are such that once the slop tank or tanks are charged with washing water, this water is sufficient for tank washing and, where applicable, for providing the driving fluid for ejectors, without the introduction of additional water into the system.

The society may accept slop tanks of any size, including absence of dedicated slop tanks, for units which:

- are dedicated to the same type of cargo for many consecutive voyages, and
- are arranged with segregated ballast tanks, and
- do not carry out tank washing on a regular basis, and
- retain on board (in cargo tanks) the total quantity of washing media, and discharge it ashore.

4 Access arrangement

4.1 General

4.1.1 (1/5/2013)

As far as practicable, permanent or movable means of access stored on board are to be provided to ensure proper survey and maintenance of cargo tanks and ballast compartments.

4.1.2 (1/5/2013)

Means of access to side and centre tanks may not be provided in the same transverse section.

Table 1 : Length of cargo tanks (1/5/2013)

Longitudinal bulkhead arrangement	Cargo tank	Condition (1)	Centreline bulkhead arrangement	Length of cargo tanks, in m	
No bulkhead	-	-	-	$(0,5 b_i / B + 0,1) L$ (2)	
Centreline bulkhead	-	-	-	$(0,25 b_i / B + 0,15) L$	
Two or more bulkheads	Wing cargo tank	-	-	0,2 L	
	Centre cargo tank	$b_i / B \geq 1/5$	-	0,2 L	
		$b_i / B < 1/5$	No		$(0,5 b_i / B + 0,1) L$
			Yes		$(0,25 b_i / B + 0,15) L$

(1) b_i is the minimum distance from the ship side to the outer longitudinal bulkhead of the i -th tank, measured inboard at right angles to the centreline at the level corresponding to the assigned summer freeboard.

(2) Not to exceed 0,2 L

4.2 Access to pipe tunnel and opening arrangement

4.2.1 Access to the pipe tunnel in the double bottom (1/5/2013)

The pipe tunnel in the double bottom is to comply with the following requirements:

- it may not communicate with the engine room
- provision is to be made for at least two exits to the open deck arranged at a maximum distance from each other. One of these exits fitted with a watertight closure may lead to the cargo pump room.

4.2.2 Doors between pipe tunnel and main pump room (1/5/2013)

Where there is a permanent access from a pipe tunnel to the main pump room, a watertight door is to be fitted complying with the requirements in Pt B, Ch 2, Sec 1, [6.2.1] for watertight doors open at sea and located below the freeboard deck. In addition the following is to be complied with:

- in addition to bridge operation, the watertight door is to be capable of being manually closed from outside the main pump room entrance
- the watertight door is to be kept closed during normal operations of the ship except when access to the pipe tunnel is required. A notice is to be affixed to the door to the effect that it may not be left open.

4.3 Access to compartments in the cargo area

4.3.1 General (1/5/2013)

Access to cofferdams, ballast tanks, cargo tanks and other compartments in the cargo area is to be direct from the open deck and such as to ensure their complete inspection. Access to double bottom compartments may be through a cargo pump room, pump room, deep cofferdam, pipe tunnel or similar compartments, subject to consideration of ventilation aspects.

4.3.2 Access to the fore peak tank (1/5/2013)

The access to the fore peak tank is to be direct from the open deck.

Alternatively, indirect access from the open deck to the fore peak tank through an enclosed space may be accepted provided that:

- The unit is only enabled to carry products having a flashpoint exceeding 60°C, or
- The unit is enabled to carry products having any flashpoint and:
 - the enclosed space is separated from the cargo tanks by cofferdams, the access is through a gas-tight bolted manhole located in the enclosed space and a warning sign is provided at the manhole stating that the fore peak tank may only be opened after:
 - it has been proven to be gas-free; or
 - any electrical equipment which is not electrically certified safe in the enclosed space is isolated

or
 - the enclosed space has a common boundary with the cargo tanks, is classified as a hazardous area (see Note 1), the equipment inside is suitable for the corresponding hazardous area and the enclosed space can be well ventilated.

Note 1: The hazardous area classification is to be defined in accordance with IEC 60092-502: Electrical installations in ships - Tankers - Special features.

4.3.3 Access through horizontal openings (1/5/2013)

For access through horizontal openings the dimensions are to be sufficient to allow a person wearing a self-contained, air-breathing apparatus and protective equipment to ascend or descend any ladder without obstruction and also to provide a clear opening to facilitate the hoisting of an injured person from the bottom of the compartment. The minimum clear opening is to be not less than 600 mm by 600 mm.

4.3.4 Access through vertical openings (1/5/2013)

For access through vertical openings the minimum clear opening is to be not less than 600 mm by 800 mm at a height of not more than 600 mm from the bottom shell plating unless gratings or other footholds are provided.

4.3.5 Oil carriers less than 5000 t deadweight (1/5/2013)

For oil carriers of less than 5000 t deadweight smaller dimensions may be approved by the Society in special circumstances, if the ability to traverse such openings or to remove an injured person can be proved to the satisfaction of the Society.

SECTION 3

STABILITY

1 Stability

1.1 Application

1.1.1 (1/5/2013)

The requirements in [1.2.2] apply to ships with the service notations:

- Oil carrier
- Oil carrier, flashpoint > 60°C.

1.2 Intact stability

1.2.1 General (1/5/2013)

The stability of the ship for the loading conditions in Pt B, Ch 3, App 2, [1.2.6] is to be in compliance with the requirements in Pt B, Ch 3, Sec 2. In addition, the requirements in [1.2.2] are to be complied with.

1.2.2 Liquid transfer operations (1/5/2013)

Ships with certain internal subdivision may be subjected to lolling during liquid transfer operations such as loading, unloading or ballasting. In order to prevent the effect of lolling, the design of oil carriers of 5000 t deadweight and

above is to be such that the following criteria are complied with:

- a) The intact stability criteria reported in b) is to be complied with for the worst possible condition of loading and ballasting as defined in c), consistent with good operational practice, including the intermediate stages of liquid transfer operations. Under all conditions the ballast tanks are to be assumed slack.
- b) The initial metacentric height GMO , in m, corrected for free surface measured at 0° heel, is to be not less than 0,15. For the purpose of calculating GMO , liquid surface corrections are to be based on the appropriate upright free surface inertia moment.
- c) The vessel is to be loaded with:
 - all cargo tanks filled to a level corresponding to the maximum combined total of vertical moment of volume plus free surface inertia moment at 0° heel, for each individual tank
 - cargo density corresponding to the available cargo deadweight at the displacement at which transverse KM reaches a minimum value
 - full departure consumable
 - 1% of the total water ballast capacity. The maximum free surface moment is to be assumed in all ballast tanks.

SECTION 4

MACHINERY AND CARGO SYSTEMS

1 General

1.1 Application

1.1.1 (1/5/2013)

The requirements of this Section apply to ships having the service notation:

- oil carrier

intended to carry products having any flashpoint.

Some departures from these requirements may be accepted for ships of less than 500 gross tonnage as indicated in Tab 1.

1.1.2 Exemptions (1/5/2013)

The requirements in Part C, Ch 1, Sec 10, [11.4.1] b) do not apply to service tanks.

1.2 Documents to be submitted

1.2.1 (1/5/2013)

The documents listed in Tab 2 are to be submitted for approval in four copies.

2 Piping systems other than cargo piping system

2.1 General

2.1.1 Materials (1/5/2013)

- Materials are to comply with the provisions of Pt C, Ch 1, Sec 10.
- Spheroidal graphite cast iron may be accepted for bilge and ballast piping.

2.1.2 Independence of piping systems (1/5/2013)

- Bilge, ballast and scupper systems serving spaces located within the cargo area:
 - are to be independent from any piping system serving spaces located outside the cargo area
 - are not to lead outside the cargo area.
- Fuel oil systems are to:
 - be independent from the cargo piping system
 - have no connections with pipelines serving cargo or slop tanks.

2.1.3 Passage through cargo tanks and slop tanks (1/5/2013)

- Unless otherwise specified, bilge, ballast and fuel oil systems serving spaces located outside the cargo area are not to pass through cargo tanks or slop tanks. They may pass through ballast tanks or void spaces located within the cargo area.
- Where expressly permitted, ballast pipes passing through cargo tanks are to fulfil the following provisions:
 - they are to have welded or heavy flanged joints the number of which is kept to a minimum
 - they are to be of extra-reinforced wall thickness as per Pt C, Ch 1, Sec 10, Tab 5
 - they are to be adequately supported and protected against mechanical damage.

2.1.4 Pumps (1/5/2013)

One or more driven pumps are to be fitted, in a suitable space forward of cargo tanks, for bilge, ballast and, where relevant, fuel oil services.

Note 1: On ships of less than 500 gross tonnage, such pumps may be omitted provided that the above services are ensured by means of equivalent arrangements, subject to the approval of the Society.

Table 1 (1/5/2013)

Subject	Reference to this Section	Feature of the ship to which departures apply	Departures
Driven pumps for bilge, ballast, etc.	[2.1.4]	< 500 GRT	equivalent arrangements accepted
Drainage of pump rooms	[2.2.3]	< 500 GRT	hand pumps permitted
Drainage of cofferdams	[2.2.5]	< 500 GRT	hand pumps permitted

Table 2 : Documents to be submitted (1/5/2013)

No.	Description of the document (1)
1	General layout of cargo pump room with details of: <ul style="list-style-type: none"> • bulkhead penetrations • gas detection system • other alarms and safety arrangements
2	Diagram of cargo piping system
3	Diagram of the cargo tank venting system with: <ul style="list-style-type: none"> • indication of the outlet position • details of the pressure/vacuum valves and flame arrestors • details of the draining arrangements, if any
4	Diagram of the cargo tank level gauging system with overfill safety arrangements
5	Diagram of the cargo tank cleaning system
6	Diagram of the bilge and ballast systems serving the spaces located in the cargo area
7	Diagram of the cargo heating systems
8	Diagram of inert gas system with details of the inert gas plant
9	Diagram of gas measurement system for double hull and double bottom spaces
(1) Diagrams are also to include, where applicable, the (local and remote) control and monitoring systems and automation systems.	

2.2 Bilge system

2.2.1 Bilge pumps (1/5/2013)

- At least one bilge pump is to be provided for draining the spaces located within the cargo area. Cargo pumps or stripping pumps may be used for this purpose.
- Bilge pumps serving spaces located within the cargo area are to be located in the cargo pump room or in another suitable space within the cargo area.

2.2.2 Draining of spaces located outside the cargo area (1/5/2013)

For bilge draining of spaces located outside the cargo area, refer to Pt C, Ch 1, Sec 10, [6].

2.2.3 Draining of pump rooms (1/5/2013)

- Arrangements are to be provided to drain the pump rooms by means of power pumps or bilge ejectors.

Note 1: On carriers of less than 500 gross tonnage, the pump rooms may be drained by means of hand pumps with a suction diameter of not less than 50 mm.

- Cargo pumps or stripping pumps may be used for draining cargo pump rooms provided that:
 - a screw-down non-return valve is fitted on the bilge suction, and
 - a remote control valve is fitted between the pump suction and the bilge distribution box.
- Bilge pipe internal diameter is not to be less than 50 mm.
- The bilge system of cargo pump rooms is to be capable of being controlled from outside.
- High liquid level in the bilges is to activate an audible and visual alarm in the cargo control room and on the navigation bridge.

2.2.4 Draining of tunnels and pump rooms other than cargo pump rooms (1/5/2013)

Arrangements are to be provided to drain tunnels and pump rooms other than cargo pump rooms. Cargo pumps may be used for this service under the provisions of [2.2.3], item b).

2.2.5 Draining of cofferdams located at the fore and aft ends of the cargo spaces (1/5/2013)

- When they are not intended to be filled with water ballast, cofferdams located at the fore and aft ends of the cargo spaces are to be fitted with drainage arrangements.
- Aft cofferdams adjacent to the cargo pump room may be drained by a cargo pump in accordance with the provisions of [2.2.3], items b) and c), or by bilge ejectors.
- Cofferdams located at the fore end of the cargo spaces may be drained by the bilge or ballast pumps required in [2.1.4], or by bilge ejectors.
- Drainage of the after cofferdam from the engine room bilge system is not permitted.

Note 1: On carriers of less than 500 gross tonnage, cofferdams may be drained by means of hand pumps with a suction diameter of not less than 50 mm.

2.2.6 Drainage of other cofferdams and void spaces located within the cargo area (1/5/2013)

Other cofferdams and void spaces located within the cargo area and not intended to be filled with water ballast are to be fitted with suitable means of drainage.

2.3 Ballast system

2.3.1 General (1/5/2013)

- a) Except where expressly permitted, ballast systems serving segregated ballast tanks are to be completely separated from the cargo oil and fuel oil systems.
- b) In oil carriers of 150 gross tonnage and above, no ballast water is normally to be carried in any fuel oil tank; see Pt C, Ch 1, Sec 10, [7.1.3].

2.3.2 Ballast pumps (1/5/2013)

- a) Ballast pumps are to be located in the cargo pump room, or a similar space within the cargo area not containing any source of ignition.
- b) Where installed in the cargo pump room, ballast pumps are to comply with the applicable provisions of [3.2.3] and [3.2.4].

2.3.3 Pumping arrangements for ballast tanks within the cargo area (1/5/2013)

- a) Ballast systems serving segregated ballast in the cargo area are to be entirely located within the cargo area and are not to be connected to other piping systems.
- b) Segregated ballast tanks located within the cargo area are to be served by two different means. At least one of these means is to be a pump or an eductor used exclusively for dealing with ballast.

2.3.4 Pumping arrangement for cofferdams located at the fore and aft ends of the cargo spaces (1/5/2013)

Where they are intended to be filled with water ballast, the cofferdams located at the fore and aft ends of the cargo spaces may be emptied by a ballast pump located inside the machinery compartment or the forward space mentioned in [2.1.4], whichever is the case, provided that:

- the suction is directly connected to the pump and not to a piping system serving machinery spaces
- the delivery is directly connected to the ship side.

2.3.5 Emergency discharge of segregated ballast (1/5/2013)

Provisions may be made for emergency discharge of the segregated ballast by means of a connection to a cargo pump through a detachable spool piece provided that:

- non-return valves are fitted on the segregated ballast connections to prevent the passage of oil to the ballast tank, and
- shut-off valves are fitted to shut off the cargo and ballast lines before the spool piece is removed.

The detachable spool piece is to be placed in a conspicuous position in the pump room and a permanent warning notice restricting its use is to be displayed in a conspicuous position adjacent to it.

2.3.6 Carriage of ballast water in cargo tanks (1/5/2013)

- a) Provisions may be made for filling cargo tanks with sea water, where permitted. Such ballast water is to be processed and discharged using the equipment referred to in [5].
- b) The sea water inlets and overboard discharges serving cargo tanks for the purpose of a) are not to have any connection with the ballast system of segregated ballast tanks.
- c) Cargo pumps may be used for pumping ballast water to or from the cargo tanks, provided two shut-off valves are fitted to isolate the cargo piping system from the sea inlets and overboard discharges. See also [5.3.4].
- d) Ballast pumps serving segregated ballast tanks may be used for filling the cargo tanks with sea water provided that the connection is made on the top of the tanks and consists of a detachable spool piece and a screw-down non-return valve to avoid siphon effects.

2.3.7 Ballast pipes passing through tanks (1/5/2013)

- a) In oil carriers of 600 tonnes deadweight and above, ballast piping is not to pass through cargo tanks except in the case of short lengths of piping complying with [2.1.3], item b).
- b) Sliding type couplings are not to be used for expansion purposes where ballast lines pass through cargo tanks. Expansion bends only are permitted.

2.3.8 Fore peak ballast system on oil carriers (1/5/2013)

The fore peak tank can be ballasted with the system serving ballast tanks within the cargo area, provided:

- a) the fore peak tank is considered a hazardous area (see Note 1)
- b) the vent pipe openings are located on open deck at an appropriate distance from sources of ignition. In this respect, the separation distances for hazardous zones are to be defined in accordance with IEC 60092-502: Electrical installations in ships - carriers - Special features;
- c) c)means are provided, on the open deck, to allow measurement of flammable gas concentrations within the fore peak tank by a suitable portable instrument;
- d) the sounding arrangements to the fore peak tank are direct from the open deck.

Note 1: The hazardous area classification is to be defined in accordance with IEC 60092-502: Electrical installations in ships - carriers - Special features.

2.3.9 Integrated cargo and ballast system (1/5/2013)

The requirements for integrated cargo and ballast systems are given in [3.5].

2.4 Air and sounding pipes of spaces other than cargo tanks

2.4.1 General (1/5/2013)

The air and sounding pipes fitted to the following spaces:

- cofferdams located at the fore and aft ends of the cargo spaces
- tanks and cofferdams located within the cargo area and not intended for cargo

are to be led to the open.

2.4.2 Air pipes (1/5/2013)

The air pipes referred to in [2.4.1] are to be arranged as per Pt C, Ch 1, Sec 10, [9] and are to be fitted with easily removable flame screens at their outlets.

2.4.3 Passage through cargo tanks (1/5/2013)

In oil carriers of 600 tonnes deadweight and above, the air and sounding pipes referred to in [2.4.1] are not to pass through cargo tanks except in the following cases:

- short lengths of piping serving ballast tanks
- lines serving double bottom tanks located within the cargo area, except in the case of oil carriers of 5000 tonnes deadweight and above

where the provisions of [2.1.3], item b) are complied with.

2.5 Scupper pipes

2.5.1 (1/5/2013)

Scupper pipes are not to pass through cargo tanks except, where this is impracticable, in the case of short lengths of piping complying with the following provisions:

- they are of steel
- they have only welded or heavy flanged joints the number of which is kept to a minimum
- they are of substantial wall thickness as per Pt C, Ch 1, Sec 10, Tab 22, column 1.

2.6 Heating systems intended for cargo

2.6.1 General (1/5/2013)

- a) Heating systems intended for cargo are to comply with the relevant requirements of Pt C, Ch 1, Sec 10.
- b) The steam and heating media temperature within the cargo area is not to exceed 220° C.
- c) Blind flanges or similar devices are to be provided on the heating circuits fitted to tanks carrying cargoes which are not to be heated.
- d) Heating systems are to be so designed that the pressure maintained in the heating circuits is higher than that exerted by the cargo oil. This need not be applied to heating circuits which are not in service provided they are drained and blanked-off.
- e) Isolating valves are to be provided at the inlet and outlet connections of the tank heating circuits. Arrangements are to be made to allow manual adjustment of the flow.
- f) Heating pipes and coils inside tanks are to be built of a material suitable for the heated fluid. They are to have welded connections only.

2.6.2 Steam heating (1/5/2013)

To reduce the risk of liquid or gaseous cargo returns inside the engine or boiler rooms, steam heating systems of cargo tanks are to satisfy either of the following provisions:

- they are to be independent of other ship services, except cargo heating or cooling systems, and are not to enter machinery spaces, or
- they are to be provided with an observation tank on the water return system located within the cargo area. However, this tank may be placed inside the engine room in a well-ventilated position remote from boilers and other sources of ignition. Its air pipe is to be led to the open and fitted with a flame arrester.

2.6.3 Hot water heating (1/5/2013)

Hot water systems serving cargo tanks are to be independent of other systems. They are not to enter machinery spaces unless the expansion tank is fitted with:

- means for detection of flammable vapours
- a vent pipe led to the open and provided with a flame arrester.

2.6.4 Thermal oil heating (1/5/2013)

Thermal oil heating systems serving cargo tanks are to be arranged by means of a separate secondary system, located completely within the cargo area. However, a single circuit system may be accepted provided that:

- the system is so arranged as to ensure a positive pressure in the coil of at least 3 m water column above the static head of the cargo when the circulating pump is not in operation
- means are provided in the expansion tank for detection of flammable cargo vapours. Portable equipment may be accepted.
- valves for the individual heating coils are provided with a locking arrangement to ensure that the coils are under static pressure at all times.

3 Cargo pumping systems

3.1 General

3.1.1 (1/5/2013)

A complete system of pumps and piping is to be fitted for handling the cargo.

3.1.2 (1/5/2013)

Except where expressly permitted, and namely for the bow and stern cargo loading and unloading stations, this system is not to extend outside the cargo area and is to be independent of any other piping system on board.

3.2 Cargo pumping system

3.2.1 Number and location of cargo pumps (1/5/2013)

- a) Each cargo tank is to be served by at least one fixed mean of discharging and stripping.

In addition, arrangements are to be adopted to make discharge by pumps in the oil terminal possible, taking

into account the NPSHD at the pumps, or a second separate fixed mean of discharging is to be fitted.

- b) Cargo pumps are to be located:
- in a dedicated pump room, or
 - on deck, or
 - when designed for this purpose, within the cargo tanks.

3.2.2 Use of cargo pumps (1/5/2013)

- a) Except where expressly permitted in [2.2] and [2.3], cargo pumps are to be used exclusively for handling the liquid cargo and are not to have any connections to compartments other than cargo tanks.
- b) Subject to their performance, cargo pumps may be used for tank stripping.
- c) Cargo pumps may be used, where necessary, for the washing of cargo tanks.

3.2.3 Cargo pumps drive (1/5/2013)

- a) Prime movers of cargo pumps are not to be located in the cargo area, except in the following cases:
- steam driven machine supplied with steam having a temperature not exceeding 220°C
 - hydraulic motors
 - electric motors of certified explosion proof type.
- b) Pumps with a submerged electric motor are not permitted in cargo tanks.
- c) Where cargo pumps are driven by a machine which is located outside the cargo pump room, the following arrangements are to be made:
- 1) drive shafts are to be fitted with flexible couplings or other means suitable to compensate for any misalignment
 - 2) the shaft bulkhead or deck penetration is to be fitted with a gas-tight gland of a type approved by the Society. The gland is to be efficiently lubricated from outside the pump room and so designed as to prevent overheating. The seal parts of the gland are to be of material that cannot initiate sparks.
 - 3) Temperature sensing devices are to be fitted for bulkhead shaft gland bearings; see [3.2.5].

Note 1: The provisions of this requirement also apply to stripping pumps and ballast pumps.

3.2.4 Design of cargo pumps (1/5/2013)

- a) Materials of cargo pumps are to be suitable for the products carried.
- b) The delivery side of cargo pumps is to be fitted with relief valves discharging back to the suction side of the

pumps (bypass) in closed circuit. Such relief valves may be omitted in the case of centrifugal pumps with a maximum delivery pressure not exceeding the design pressure of the piping, with the delivery valve closed.

- c) Pump casings are to be fitted with temperature sensing devices; see [3.2.5].

3.2.5 Monitoring of cargo pumps (1/5/2013)

Cargo pumps are to be monitored as required in Tab 3.

3.2.6 Control of cargo pumps (1/5/2013)

Cargo pumps are to be capable of being stopped from:

- a position outside the pump room, and
- a position next to the pumps.

3.3 Cargo piping design

3.3.1 General (1/5/2013)

- a) Unless otherwise specified, cargo piping is to be designed and constructed according to the requirements of Pt C, Ch 1, Sec 10 applicable to piping systems of class III.
- b) For tests, refer to [6].

3.3.2 Materials (1/5/2013)

- a) Cargo piping is, in general, to be made of steel or cast iron.
- b) Valves, couplings and other end fittings of cargo pipe lines for connection to hoses are to be of steel or other suitable ductile material.
- c) Spheroidal graphite cast iron may be used for cargo oil piping.
- d) Grey cast iron may be accepted for cargo oil lines:
- within cargo tanks, and
 - on the weather deck for pressure up to 1,6 Mpa.

It is not to be used for manifolds and their valves of fittings connected to cargo handling hoses.

- e) Plastic pipes may be used in the conditions specified in Pt C, Ch 1, App 3. Arrangements are to be made to avoid the generation of static electricity.

3.3.3 Connection of cargo pipe lengths (1/5/2013)

Cargo pipe lengths may be connected either by means of welded joints or, unless otherwise specified, by means of flange connections.

Table 3 : Monitoring of cargo pumps (1/5/2013)

Equipment, parameter	Alarm (1)	Indication (2)	Comments
pump, discharge pressure		L	<ul style="list-style-type: none"> • on the pump (3), or • next to the unloading control station
pump casing, temperature	H		visual and audible, in cargo control room or pump control station
bulkhead shaft gland bearing, temperature	H		visual and audible, in cargo control room or pump control station
(1) H = high (2) L = low (3) and next to the driving machine if located in a separate compartment			

3.3.4 Expansion joints (1/5/2013)

- Where necessary, cargo piping is to be fitted with expansion joints or bends.
- Expansion joints including bellows are to be of a type approved by the Society.
- Expansion joints made of non-metallic material may be accepted only inside tanks and provided they are:
 - of an approved type
 - designed to withstand the maximum internal and external pressure
 - electrically conductive.
- Sliding type couplings are not to be used for expansion purposes where lines for cargo oil pass through tanks for segregated ballast.

3.3.5 Valves with remote control (1/5/2013)

- Valves with remote control are to comply with Pt C, Ch 1, Sec 10, [2.7.3].
- Submerged valves are to be remote controlled. In the case of a hydraulic remote control system, control boxes are to be provided outside the tank, in order to permit the emergency control of valves.
- Valve actuators located inside cargo tanks are not to be operated by means of compressed air.

3.3.6 Cargo hoses (1/5/2013)

- Cargo hoses are to be of a type approved by the Society for the intended conditions of use.
- Hoses subject to tank pressure or pump discharge pressure are to be designed for a bursting pressure not less than 4 times the maximum pressure under cargo transfer conditions.
- The ohmic electrical resistance of cargo hoses is not to exceed $10^6 \Omega$.

3.4 Cargo piping arrangement and installation**3.4.1 Cargo pipes passing through tanks or compartments (1/5/2013)**

- Cargo piping is not to pass through tanks or compartments located outside the cargo area.
- Cargo piping and similar piping to cargo tanks is not to pass through ballast tanks except in the case of short lengths of piping complying with [2.1.3], item b).
- Cargo piping may pass through vertical fuel oil tanks adjacent to cargo tanks on condition that the provisions of [2.1.3], item b) are complied with.
- Piping through cargo tanks, see also Sec 2, [3.1.4].

3.4.2 Cargo piping passing through bulkheads (1/5/2013)

Cargo piping passing through bulkheads is to be so arranged as to preclude excessive stresses at the bulkhead. Bolted flanges are not to be used in the bulkhead.

3.4.3 Valves (1/5/2013)

- Stop valves are to be provided to isolate each tank.
- A stop valve is to be fitted at each end of the cargo manifold.
- When a cargo pump in the cargo pump room serves more than one cargo tank, a stop valve is to be fitted in the cargo pump room on the line leading to each tank.
- Main cargo oil valves located in the cargo pump room below the floor gratings are to be remote controlled from a position above the floor.

3.4.4 Prevention of the generation of static electricity (1/5/2013)

To avoid the hazard of an incendive discharge due to the build-up of static electricity resulting from the flow of the liquid/gases/vapours, the following requirements are to be complied with:

- the loading pipes are to be led as low as practicable in the tank
- the resistance between any point on the surface of the cargo and slop tanks, piping systems and equipment, and the hull of the ship is not to be greater than $10^6 \Omega$.

Bonding straps are required for cargo and slop tanks, piping systems and equipment which are not permanently connected to the hull of the ship, for example:

- independent cargo tanks
- cargo tank piping systems which are electrically separated from the hull of the ship
- pipe connections arranged for the removal of the spool pieces.

Where bonding straps are required, they are to be:

- clearly visible so that any shortcoming can be clearly detected
- designed and sited so that they are protected against mechanical damage and are not affected by high resistivity contamination, e.g. corrosive products or paint
- easy to install and replace.

3.4.5 Bow or stern cargo loading and unloading arrangements (1/5/2013)

Where the ship is arranged for loading and unloading outside the cargo area, the following provisions are to be complied with:

- the piping outside the cargo area is to be fitted with a shut-off valve at its connection with the piping system within the cargo area and separating means such as blank flanges or removable spool pieces or equivalent (see Note 1) are to be provided when the piping within the cargo area is not in use

Note 1: Those indicated in the IMO MSC/Circ. 474 are acceptable as equivalent

- the shore connection is to be fitted with a shut-off valve and a blank flange
- pipe connections outside the cargo area are to be of welded type only
- arrangements are made to allow the piping outside the cargo area to be efficiently drained and purged.

3.4.6 Draining of cargo pumps and oil lines (1/5/2013)

Every oil carrier required to be provided with segregated ballast tanks or fitted with a crude oil washing system is to comply with the following requirements:

- it is to be equipped with oil piping so designed and installed that oil retention in the lines is minimised, and
- means are to be provided to drain all cargo pumps and all oil lines at the completion of cargo discharge, where necessary by connection to a stripping device. The line and pump drainings are to be capable of being discharged both ashore and to a cargo tank or slop tank. For discharge ashore, a special small diameter line having a cross-sectional area not exceeding 10% of the main cargo discharge line is to be provided and is to be connected on the downstream side of the carrier's deck manifold valves, both port and starboard, when the cargo is being discharged; see Fig 1.

For oil carriers fitted with a crude oil washing system, refer also to Ch 7, App 2, [2.4.5].

Figure 1 : Connection of small diameter line to the manifold valve (1/5/2013)

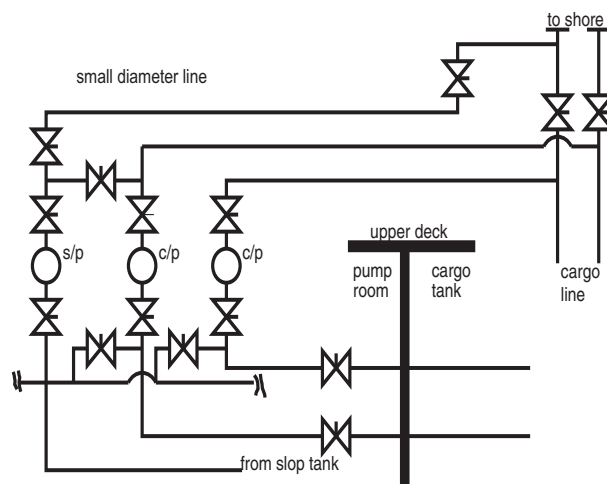

3.4.7 Cleaning and gas-freeing (1/5/2013)

- The cargo piping system is to be so designed and arranged as to permit its efficient cleaning and gas-freeing.
- Requirements for inert gas systems are given in Part C, Chapter 4.

3.5 Integrated cargo and ballast systems design

3.5.1 Functional requirements (1/5/2013)

The operation of cargo and/or ballast systems may be necessary, under certain emergency circumstances or during the course of navigation, to enhance the safety of carriers.

As such, measures are to be taken to prevent cargo and ballast pumps becoming inoperative simultaneously due to a single failure in the integrated cargo and ballast system, including its control and safety systems. The same criteria apply to control systems of cargo and ballast valves.

3.5.2 Design features (1/5/2013)

The following design features are, inter alia, to be fitted:

- the emergency stop circuits of the cargo and ballast systems are to be independent from the circuits for the control systems. A single failure in the control system circuits or the emergency stop circuits is not to render the integrated cargo and ballast system inoperative;
- manual emergency stops of the cargo pumps are to be arranged such that they do not cause the shutdown of the power pack making ballast pumps inoperative;
- the control systems are to be provided with backup power supply, which may be satisfied by a duplicate power supply from the main switchboard. The failure of any power supply is to provide audible and visible alarm activation at each location where the control panel is fitted.

- d) in the event of failure of the automatic or remote control systems, a secondary means of control is to be made available for the operation of the integrated cargo and ballast system. This is to be achieved by manual overriding and/or redundant arrangements within the control systems.

4 Cargo tanks and fittings

4.1 Application

4.1.1 (1/5/2013)

The provisions of [4] apply to cargo tanks and slop tanks.

4.2 Cargo tank venting

4.2.1 Principle (1/5/2013)

Cargo tanks are to be provided with venting systems entirely distinct from the air pipes of the other compartments of the ship. The arrangements and position of openings in the cargo tank deck from which emission of flammable vapours can occur are to be such as to minimise the possibility of flammable vapours being admitted to enclosed spaces containing a source of ignition, or collecting in the vicinity of deck machinery and equipment which may constitute an ignition hazard.

4.2.2 Design of venting arrangements (1/5/2013)

The venting arrangements are to be so designed and operated as to ensure that neither pressure nor vacuum in cargo tanks exceeds design parameters and be such as to provide for:

- the flow of the small volumes of vapour, air or inert gas mixtures caused by thermal variations in a cargo tank in all cases through pressure/vacuum valves, and
- the passage of large volumes of vapour, air or inert gas mixtures during cargo loading and ballasting, or during discharging,
- a secondary means of allowing full flow relief of vapour, air or inert gas mixtures to prevent overpressure or underpressure in the event of failure of the arrangements in b). Alternatively, pressure sensors may be fitted in each tank protected by the arrangement required in b), with a monitoring system in the ship's cargo control room or the position from which cargo operations are normally carried out. Such monitoring equipment is also to provide an alarm facility which is activated by detection of overpressure or underpressure conditions within a tank.

4.2.3 Combination of venting arrangements (1/5/2013)

- The venting arrangements in each cargo tank may be independent or combined with other cargo tanks and may be incorporated into the inert gas piping.
- Where the arrangements are combined with other cargo tanks, either stop valves or other acceptable means are to be provided to isolate each cargo tank. Where stop valves are fitted, they are to be provided with locking arrangements which are to be under the control of the responsible ship's officer. There is to be a clear visual

indication of the operational status of the valves or other acceptable means. Where tanks have been isolated, it is to be ensured that relevant isolating valves are opened before cargo loading or ballasting or discharging of those tanks is commenced. Any isolation must continue to permit the flow caused by thermal variations in a cargo tank in accordance with [4.2.2] a).

- If cargo loading or ballasting or discharging of a cargo tank or cargo tank group is intended, which is isolated from a common venting system, that cargo tank or cargo tank group is to be fitted with a means for overpressure or underpressure protection as required in [4.2.2] c).

4.2.4 Arrangement of vent lines (1/5/2013)

The venting arrangements are to be connected to the top of each cargo tank and are to be self-draining to the cargo tanks under all normal conditions of trim and list of the ship. Where it may not be possible to provide self-draining lines, permanent arrangements are to be provided to drain the vent lines to a cargo tank.

Plugs or equivalent means are to be provided on the lines after the safety relief valves.

4.2.5 Openings for pressure release (1/5/2013)

Openings for pressure release required by [4.2.2] a) are to:

- have as great a height as is practicable above the cargo tank deck to obtain maximum dispersal of flammable vapours but in no case less than 2 m above the cargo tank deck,
- be arranged at the furthest distance practicable but not less than 5 m from the nearest air intakes and openings to enclosed spaces containing a source of ignition and from deck machinery and equipment which may constitute an ignition hazard. Anchor windlass and chain locker openings constitute an ignition hazard.

4.2.6 Pressure/vacuum valves (1/5/2013)

- One or more pressure/vacuum-breaking devices are to be provided to prevent the cargo tanks from being subject to:
 - a positive pressure, in excess of the test pressure of the cargo tank, if the cargo were to be loaded at the maximum rated capacity and all other outlets were left shut; and
 - a negative pressure in excess of 700 mm water gauge if cargo were to be discharged at the maximum rated capacity of the cargo pumps and the inert gas blowers were to fail.

Such devices are to be installed on the inert gas main unless they are installed in the venting system required by this item [4.2] or on individual cargo tanks.

- Pressure/vacuum valves are to be set at a positive pressure not exceeding 0,021 MPa and at a negative pressure not exceeding 0,007 MPa. Higher setting values not exceeding 0,07 MPa may be accepted in positive pressure if the scantlings of the tanks are appropriate.
- Pressure/vacuum valves required by item a) of [4.2.2] may be provided with a bypass when they are located in a vent main or masthead riser. Where such an arrange-

ment is provided, there are to be suitable indicators to show whether the bypass is open or closed.

- d) Pressure/vacuum valves are to be of a type approved by the Society in accordance with Ch 7, App 1.
- e) Pressure/vacuum valves are to be readily accessible.
- f) Pressure/vacuum valves are to be provided with a manual opening device so that valves can be locked on open position. Locking means on closed position are not permitted.

4.2.7 Vent outlets (1/5/2013)

Vent outlets for cargo loading, discharging and ballasting required by [4.2.2] b) are to:

- a) permit:
 - the free flow of vapour mixtures, or
 - the throttling of the discharge of the vapour mixtures to achieve a velocity of not less than 30 m/s,
- b) be so arranged that the vapour mixture is discharged vertically upwards,
- c) where the method is by free flow of vapour mixtures, be such that the outlet is not less than 6 m above the cargo tank deck or fore and aft gangway if situated within 4 m of the gangway and located not less than 10 m measured horizontally from the nearest air intakes and openings to enclosed spaces containing a source of ignition and from deck machinery which may include anchor windlass and chain locker openings, and equipment which may constitute an ignition hazard,
- d) where the method is by high velocity discharge, be located at a height not less than 2 m above the cargo tank deck and not less than 10 m measured horizontally from the nearest air intakes and openings to enclosed spaces containing a source of ignition and from deck machinery which may include anchor windlass and chain locker openings, and equipment which may constitute an ignition hazard. These outlets are to be provided with high velocity devices of a type approved by the Society,
- e) be designed on the basis of the maximum designed loading rate multiplied by a factor of at least 1.25 to take account of gas evolution, in order to prevent the pressure in any cargo tank from exceeding the design pressure. The Master is to be provided with information regarding the maximum permissible loading rate for each cargo tank and in the case of combined venting systems, for each group of cargo tanks.

The arrangements for the venting of vapours displaced from the cargo tanks during loading and ballasting are to comply with this item [4.2] and are to consist of either one or more mast risers, or a number of high-velocity vents. The inert gas supply main may be used for such venting.

4.2.8 High velocity valves (1/5/2013)

- a) High velocity valves are to be readily accessible.
- b) High velocity valves not required to be fitted with flame arresters (see [4.2.9]) are not to be capable of being locked on open position.

4.2.9 Prevention of the passage of flame into the tanks (1/5/2013)

- a) The venting system is to be provided with devices to prevent the passage of flame into the cargo tanks. The design, testing and locating of these devices are to comply with Ch 7, App 1.

Ullage openings are not to be used for pressure equalisation. They are to be provided with self-closing and tightly sealing covers. Flame arresters and screens are not permitted in these openings.

- b) A flame arresting device integral to the venting system may be accepted.
- c) Flame screens and flame arresters are to be designed for easy overhauling and cleaning.

4.2.10 Prevention of liquid rising in the venting system (1/5/2013)

- a) Provisions are to be made to prevent liquid rising in the venting system; refer to [4.5].
- b) Cargo tanks gas venting systems are not to be used for overflow purposes.
- c) Spill valves are not considered equivalent to an overflow system.

4.3 Cargo tank purging and/or gas-freeing

4.3.1 General (1/5/2013)

- a) Arrangements are to be made for purging and/or gas-freeing of cargo tanks. The arrangements are to be such as to minimise the hazards due to the dispersal of flammable vapours in the atmosphere and to flammable mixtures in a cargo tank. Accordingly, the provisions of [4.3.2] and [4.3.3], as applicable, are to be complied with.
- b) In the case of fans installed in safe spaces, two non-return devices are to be fitted to avoid return of cargo vapours to safe spaces when the ventilation system is shut down. These non-return devices are to operate in all normal conditions of ship trim and list.
- c) Discharge outlets are to be located at least 10 m measured horizontally from the nearest air intake and openings to enclosed spaces with a source of ignition and from deck machinery equipment which may constitute an ignition hazard.

4.3.2 Ships provided with an inert gas system (1/5/2013)

When the ship is provided with an inert gas system, the cargo tanks are first to be purged in accordance with the provisions of Part C, Chapter 4 until the concentration of hydrocarbon vapours in the cargo tanks has been reduced to less than 2% by volume. Thereafter, gas-freeing may take place at the cargo tank deck level.

4.3.3 Ships not provided with an inert gas system (1/5/2013)

When the ship is not provided with an inert gas system, the operation is to be such that the flammable vapour is discharged initially:

- a) through the vent outlets as specified in [4.2.7], or
- b) through outlets at least 2 m above the cargo tank deck level with a vertical efflux velocity of at least 30 m/s maintained during the gas-freeing operation, or
- c) through outlets at least 2 m above the cargo tank deck level with a vertical efflux velocity of at least 20 m/s and which are protected by suitable devices to prevent the passage of flame.

The above outlets are to be located not less than 10 m measured horizontally from the nearest air intakes and openings to enclosed spaces containing a source of ignition and from deck machinery, which may include anchor windlass and chain locker openings, and equipment which may constitute an ignition hazard.

When the flammable vapour concentration at the outlet has been reduced to 30% of the lower flammable limit, gas-freeing may thereafter be continued at cargo tank deck level.

4.4 Cargo tank level gauging systems

4.4.1 General (1/5/2013)

- a) Each cargo or slop tank is to be fitted with a level gauging system indicating the liquid level along the entire height of the tank. Unless otherwise specified, the gauge may be portable or fixed with local reading.
- b) Gauging devices and their remote reading systems are to be type approved.
- c) Ullage openings and other gauging devices likely to release cargo vapour to the atmosphere are not to be arranged in enclosed spaces.

4.4.2 Definitions (1/5/2013)

- a) A "restricted gauging device" means a device which penetrates the tank and which, when in use, permits a small quantity of vapour or liquid to be exposed to the atmosphere. When not in use, the device is completely closed. Examples are sounding pipes.
- b) A "closed gauging device" means a device which is separated from the tank atmosphere and keeps tank contents from being released. It may:
 - penetrate the tank, such as float-type systems, electric probe, magnetic probe or protected sight glass,
 - not penetrate the tank, such as ultrasonic or radar devices.
- c) An "indirect gauging device" means a device which determines the level of liquid, for instance by means of weighing or pipe flow meter.

4.4.3 Oil carriers fitted with an inert gas system (1/5/2013)

- a) In carriers fitted with an inert gas system, the gauging devices are to be of the closed type.
- b) Use of indirect gauging devices will be given special consideration.

4.4.4 Oil carriers not fitted with an inert gas system (1/5/2013)

- a) In carriers not fitted with an inert gas system, the gauging devices are to be of the closed or restricted types. Ullage openings may be used only as a reserve sounding means and are to be fitted with a watertight closing appliance.
- b) Where restricted gauging devices are used, provisions are to be made to:
 - avoid dangerous escape of liquid or vapour under pressure when using the device
 - relieve the pressure in the tank before the device is operated.
- c) Where used, sounding pipes are to be fitted with a self-closing blanking device.

4.5 Protection against tank overload

4.5.1 General (1/5/2013)

- a) Provisions are to be made to guard against liquid rising in the venting system of cargo or slop tanks to a height which would exceed the design head of the tanks. This is to be accomplished by high level alarms or overflow control systems or other equivalent means, together with gauging devices and cargo tank filling procedures.
- b) Sufficient ullage is to be left at the end of tank filling to permit free expansion of liquid during carriage.
- c) High level alarms, overflow control systems and other means referred to in a) are to be independent of the gauging systems referred to in [4.4].

4.5.2 High level alarms (1/5/2013)

- a) High level alarms are to be type approved.
- b) High level alarms are to give an audible and visual signal at the control station, where provided.

4.5.3 Other protection systems (1/5/2013)

- a) Where the tank level gauging systems, cargo and ballast pump control systems and valve control systems are centralised in a single location, the provisions of [4.5.1] may be complied with by the fitting of a level gauge for the indication of the end of loading, in addition to that required for each tank under [4.4]. The readings of both gauges for each tank are to be as near as possible to each other and so arranged that any discrepancy between them can be easily detected.
- b) Where a tank can be filled only from other tanks, the provisions of [4.5.1] are considered as complied with.

4.6 Tank washing systems

4.6.1 General (1/5/2013)

- a) Adequate means are to be provided for cleaning the cargo tanks, except on units which:
- are dedicated to the same type of cargo for many consecutive voyages, and
 - are arranged with segregated ballast tanks according to Sec 2, [5], and
 - do not carry out tank washing on a regular basis, and
 - use shore services for tank washing and disposal of washing media and residues, when needed.
- b) Crude oil washing, when fitted, are to comply with the provisions of Ch 7, App 2 related to safety.

4.6.2 Washing machines (1/5/2013)

- a) Tank washing machines are to be of a type approved by the Society.
- b) Washing machines are to be made of steel or other electricity conducting materials with a limited propensity to produce sparks on contact.

4.6.3 Washing pipes (1/5/2013)

- a) Washing pipes are to be built, fitted, inspected and tested in accordance with the applicable requirements of Pt C, Ch 1, Sec 10, depending on the kind of washing fluid, water or crude oil.
- b) Crude oil washing pipes are also to satisfy the requirements of [3.3].

4.6.4 Use of crude oil washing machines for water washing operations (1/5/2013)

Crude oil washing machines may be connected to water washing pipes, provided that isolating arrangements, such as a valve and a detachable pipe section, are fitted to isolate water pipes.

4.6.5 Installation of washing systems (1/5/2013)

- a) Tank cleaning openings are not to be arranged in enclosed spaces.
- b) The complete installation is to be permanently earthed to the hull.

5 Prevention of pollution by cargo oil

5.1 General

5.1.1 Application (1/5/2013)

Unless otherwise specified, the provisions of [5.2] and [5.3] apply only to oil carriers of 150 gross tonnage and above.

5.1.2 Provisions for oil carriers of less than 150 gross tonnage (1/5/2013)

The control of discharge for **oil carriers** of less than 150 gross tonnage is to be effected by the retention of oil on board with subsequent discharge of all contaminated washings to reception facilities unless adequate arrangements are made to ensure that the discharge of any effluent into the sea, where allowed, is effectively monitored to ensure

that the total quantity of oil discharged into the sea does not exceed 1/30 000 of the total quantity of the particular cargo of which the residue formed a part.

5.1.3 Exemptions (1/5/2013)

The provisions of [5.2] and [5.3] may be waived in the following cases:

- oil carriers engaged exclusively on voyages within 50 miles from the nearest land and of 72 hours or less in duration and limited to trades between ports or terminals agreed by the Society, provided that oily mixtures are retained on board for subsequent discharge to reception facilities
- carrying products which through their physical properties inhibit effective product/water separation and monitoring, for which the control of discharge is to be effected by the retention of residues on board with discharge of all contaminated washings to reception facilities

5.2 Retention of oil on board

5.2.1 General (1/5/2013)

Adequate means are to be provided for transferring the dirty ballast residue and tank washings from the cargo tanks into a slop tank approved by the Society.

5.2.2 Capacity of slop tanks (1/5/2013)

The arrangement of the slop tank or combination of slop tanks is to have a capacity necessary to retain the slop generated by tank washings, oil residues and dirty ballast residues. The total capacity of the slop tank or tanks is not to be less than 3% of the oil carrying capacity of the ship, except that the Society may accept:

- a) 2% for oil carriers where the tank washing arrangements are such that once the slop tank or tanks are charged with washing water, this water is sufficient for tank washing and, where applicable, for providing the driving fluid for eductors, without the introduction of additional water into the system
- b) 2% where segregated ballast tanks are provided in accordance with Sec 2, [3], or where a cargo tank cleaning system using crude oil washing is fitted in accordance with [4.6]. This capacity may be further reduced to 1,5% for oil carriers where the tank washing arrangements are such that once the slop tank or tanks are charged with washing water, this water is sufficient for tank washing and, where applicable, for providing the driving fluid for eductors, without introduction of additional water into the system.
- c) slop tanks of any size, including absence of dedicated slop tanks, for units which:
- are dedicated to the same type of cargo for many consecutive voyages, and
 - are arranged with segregated ballast tanks according to [5], and
 - do not carry out tank washing on a regular basis.

Oil carriers of 70 000 tonnes deadweight and above are to be fitted with at least two slop tanks.

5.2.3 Design of slop tanks (1/5/2013)

Slop tanks are to be so designed particularly in respect of the position of inlets, outlets, baffles or weirs where fitted, as to avoid excessive turbulence and entrainment of oil or emulsion with the water.

5.3 Pumping, piping and discharge arrangements

5.3.1 Discharge manifold (1/5/2013)

In every oil carrier, a discharge manifold for connection to reception facilities for the discharge of dirty ballast water or oil contaminated water is to be located on the open deck on both sides of the ship.

5.3.2 Discharge pipelines (1/5/2013)

In every oil carrier, pipelines for the discharge of ballast water or oil contaminated water from cargo tank areas to the sea, where permitted, are to be led to the open deck or to the ship side above the waterline in the deepest ballast condition, except that:

- a) segregated ballast and clean ballast may be discharged below the waterline:
 - in ports or at offshore terminals, or
 - at sea by gravity,

provided that the surface of the ballast water has been examined immediately before the discharge to ensure that no contamination with oil has taken place.

- b) on every oil carrier at sea, dirty ballast water or oil contaminated water from tanks in the cargo area, other than slop tanks, may be discharged by gravity below the waterline, provided that sufficient time has elapsed in order to allow oil/water separation to have taken place and the water ballast has been examined immediately before the discharge with an oil/water interface detector, in order to ensure that the height of the interface is such that the discharge does not involve any increased risk of harm to the marine environment.

5.3.3 Discharge stopping (1/5/2013)

Means are to be provided for stopping the discharge into the sea of ballast water or oil contaminated water from cargo tank areas, other than those discharges below the waterline permitted under [5.3.2], from a position on the upper deck or above located so that the manifold in use referred to in [5.3.1] and the discharge to the sea from the pipelines referred to in [5.3.2] may be visually observed. Means for stopping the discharge need not be provided at the observation position if a positive communication system such as a telephone or radio system is provided between the observation position and the discharge control position.

5.3.4 Cargo piping connections to sea chests (1/5/2013)

On every oil carrier where a sea chest is permanently connected to the cargo pipeline system, it is to be equipped with both a sea chest valve and an inboard isolation valve. In addition to these valves, the sea chest is to be capable of

isolation from the cargo piping system whilst the carrier is loading, transporting or discharging cargo by use of a positive means that is to the satisfaction of the Society. Such a positive means is a facility that is installed in the pipeline system in order to prevent the section of pipeline between the sea chest valve and the inboard valve being filled with cargo under all circumstances.

Examples of positive means may take the form of blanks, spectacle blanks, pipeline blinds, evacuation or vacuum systems, or air or water pressure systems. In the event that evacuation or vacuum systems, or air or water pressure systems are used, then they are to be equipped with both a pressure gauge and alarm system to enable the continuous monitoring of the status of the pipeline section, and thereby the valve integrity, between the sea chest and inboard valves.

6 Certification, inspection and testing

6.1 Application

6.1.1 (1/5/2013)

The provisions of this Article are related to cargo piping and other equipment fitted in the cargo area. They supplement those given in Pt C, Ch 1, Sec 10, [21] for piping systems.

6.2 Workshop tests

6.2.1 Tests for materials (1/5/2013)

Where required in Tab 4, materials used for pipes, valves and fittings are to be subjected to the tests specified in Pt C, Ch 1, Sec 10, [21.3.2].

6.2.2 Hydrostatic testing (1/5/2013)

- a) Where required in Tab 4, cargo pipes, valves, fittings and pump casings are to be submitted to hydrostatic tests in accordance with the relevant provisions of Pt C, Ch 1, Sec 10, [21.4].
- b) Expansion joints and cargo hoses are to be submitted to hydrostatic tests in accordance with the relevant provisions of Pt C, Ch 1, Sec 10, [21.4].
- c) Where fitted, bellow pieces of gas-tight penetration glands are to be pressure tested.

6.2.3 Tightness tests (1/5/2013)

Tightness of the following devices is to be checked:

- gas-tight penetration glands
- cargo tank P/V and high velocity valves.

Note 1: These tests may be carried out in the workshops or on board.

6.2.4 Check of the safety valves setting (1/5/2013)

The setting pressure of the pressure/vacuum valves is to be checked in particular with regard to [4.2.6].

6.2.5 Summary table (1/5/2013)

Inspections and tests required for cargo piping and other equipment fitted in the cargo area are summarised in Tab 4.

6.3 Shipboard tests

6.3.1 Pressure test (1/5/2013)

- a) After installation on board, the cargo piping system is to be checked for leakage under operational conditions.
- b) The piping system used in crude oil washing systems is to be submitted to hydrostatic tests in accordance with Ch 7, App 2, [3.2.1].

6.3.2 Survey of pollution prevention equipment (1/5/2013)

Every oil carrier of 150 gross tonnage and above is to be subjected to an initial survey before the ship is put in service, to ensure that the equipment, systems, fittings, arrangements and materials fully comply with the relevant provisions of [4.6] and [5].

Table 4 : Inspection and testing at works (1/5/2013)

No.	Item	Tests for materials		Inspections and tests for the products			References
		Y/N (1)	Type of material certificate (2)	during manufacturing (1)	after completion (1) (3)	Type of product certificate (2)	
1	expansion joints and cargo hoses	Y (4)	W	N	Y	C	[6.2.1] [6.2.3]
2	cargo pumps	Y	W	Y (5)	Y	C	see note (5) [6.2.3]
3	gas-tight penetration glands	N		N	Y	C	[6.2.3], [6.2.4]
4	cargo tank P/V and high velocity valves	Y	C	Y	Y	C	[6.2.1] [6.2.2] [6.2.3], [6.2.4], [6.2.5]
5	flame arresters	N		N	Y	C	see note (3)

(1) Y = required, N = not required.
(2) C = class certificate, W = works' certificate.
(3) includes the checking of the rule characteristics according to the approved drawings.
(4) if metallic.
(5) inspection during manufacturing is to be carried out according to a program approved by the Society.

SECTION 5

MACHINERY AND CARGO SYSTEMS FOR OIL CARRIER, FLASHPOINT > 60°C

1 General

1.1 Application

1.1.1 (1/5/2013)

The requirements of this Section apply to ships having the service notation:

- oil carried, flashpoint > 60°C

intended to carry products having flashpoint > 60°C, at a temperature below and not within 15°C of their flashpoint.

1.2 Documents to be submitted

1.2.1 (1/5/2013)

The documents listed in Tab 1 are to be submitted for approval in four copies.

2 Piping systems other than cargo piping system

2.1 General

2.1.1 Materials (1/5/2013)

- Materials are to comply with the provisions of Pt C, Ch 1, Sec 10.
- Spheroidal graphite cast iron may be accepted for bilge and ballast piping.

2.1.2 Independence of piping systems (1/5/2013)

- Fuel oil systems are to:
 - be independent from the cargo piping system
 - have no connections with pipelines serving cargo or slop tanks.

2.1.3 Passage through cargo tanks and slop tanks (1/5/2013)

- Unless otherwise specified, bilge, ballast and fuel oil systems serving spaces located outside the cargo area are not to pass through cargo tanks or slop tanks. They may pass through ballast tanks or void spaces located within the cargo area.

- Where expressly permitted (see [2.3.5]), ballast pipes passing through cargo tanks are to fulfil the following provisions:

- they are to have welded or heavy flanged joints the number of which is kept to a minimum
- they are to be of extra-reinforced wall thickness as per Pt C, Ch 1, Sec 10, Tab 5
- they are to be adequately supported and protected against mechanical damage.

2.2 Bilge system

2.2.1 Draining of spaces located outside the cargo area (1/5/2013)

For bilge draining of spaces located outside the cargo area, refer to Pt C, Ch 1, Sec 10, [6].

2.2.2 Draining of pump rooms (1/5/2013)

- Arrangements are to be provided to drain the pump rooms by means of power pumps or bilge ejectors.

Note 1: On carriers of less than 500 gross tonnage, the pump rooms may be drained by means of hand pumps with a suction diameter of not less than 50 mm.

- Cargo pumps or stripping pumps may be used for draining cargo pump rooms provided that:
 - a screw-down non-return valve is fitted on the bilge suction.
- Bilge pipe internal diameter is not to be less than 50 mm.
- High liquid level in the bilges is to activate an audible and visual alarm in the cargo control room and on the navigation bridge.

2.2.3 Drainage of hold spaces, cofferdams and void spaces located within the cargo area (1/5/2013)

Hold spaces, cofferdams and void spaces located within the cargo area and not intended to be filled with water ballast are to be fitted with suitable means of drainage.

2.3 Ballast system

2.3.1 General (1/5/2013)

- Except where expressly permitted, ballast systems serving segregated ballast tanks are to be completely separated from the cargo oil and fuel oil systems.
- In oil carriers of 150 gross tonnage and above, no ballast water is normally to be carried in any fuel oil tank; see Pt C, Ch 1, Sec 10, [7.1.3].

Table 1 : Documents to be submitted (1/5/2013)

No.	Description of the document (1)
1	Diagram of cargo piping system
2	Diagram of the cargo tank venting system with indication of the outlet position
3	Diagram of the cargo tank level gauging system with overflow safety arrangements
4	Diagram of the cargo tank cleaning system
5	Diagram of the bilge and ballast systems serving the spaces located in the cargo area
6	Diagram of the cargo heating systems
(1) Diagrams are also to include, where applicable, the (local and remote) control and monitoring systems and automation systems.	

2.3.2 Pumping arrangements for ballast tanks within the cargo area (1/5/2013)

Segregated ballast tanks located within the cargo area are to be served by two different means. At least one of these means is to be a pump or an eductor used exclusively for dealing with ballast. The ballast system serving the spaces located outside the cargo area may be used for this purpose.

2.3.3 Emergency discharge of segregated ballast (1/5/2013)

Provisions may be made for emergency discharge of the segregated ballast by means of a connection to a cargo pump through a detachable spool piece provided that:

- non-return valves are fitted on the segregated ballast connections to prevent the passage of oil to the ballast tank, and
- shut-off valves are fitted to shut off the cargo and ballast lines before the spool piece is removed.

The detachable spool piece is to be placed in a conspicuous position in the pump room and a permanent warning notice restricting its use is to be displayed in a conspicuous position adjacent to it.

2.3.4 Carriage of ballast water in cargo tanks (1/5/2013)

- Provisions may be made for filling cargo tanks with sea water, where permitted. Such ballast water is to be processed and discharged using the equipment referred to in [5].
- The sea water inlets and overboard discharges serving cargo tanks for the purpose of a) are not to have any connection with the ballast system of segregated ballast tanks.
- Cargo pumps may be used for pumping ballast water to or from the cargo tanks, provided two shut-off valves are fitted to isolate the cargo piping system from the sea inlets and overboard discharges. See also [5.3.4].
- Ballast pumps serving segregated ballast tanks may be used for filling the cargo tanks with sea water provided that the connection is made on the top of the tanks and consists of a detachable spool piece and a screw-down non-return valve to avoid siphon effects.

2.3.5 Ballast pipes passing through tanks (1/5/2013)

- In oil carriers of 600 tonnes deadweight and above, ballast piping is not to pass through cargo tanks except in the case of short lengths of piping complying with [2.1.3], item b).
- Sliding type couplings are not to be used for expansion purposes where ballast lines pass through cargo tanks. Expansion bends only are permitted.

2.3.6 Integrated cargo and ballast system (1/5/2013)

The requirements for integrated cargo and ballast systems are given in [3.5].

2.4 Scupper pipes

2.4.1 (1/5/2013)

Scupper pipes are not to pass through cargo tanks except, where this is impracticable, in the case of short lengths of piping complying with the following provisions:

- they are of steel
- they have only welded or heavy flanged joints the number of which is kept to a minimum
- they are of substantial wall thickness as per Pt C, Ch 1, Sec 10, Tab 22, column 1.

2.5 Heating systems intended for cargo

2.5.1 General (1/5/2013)

Heating systems intended for cargo are to comply with the relevant requirements of Pt C, Ch 1, Sec 10.

3 Cargo pumping and piping systems

3.1 General

3.1.1 (1/5/2013)

A complete system of pumps and piping is to be fitted for handling the cargo.

3.2 Cargo pumping system

3.2.1 Number and location of cargo pumps (1/5/2013)

Each cargo tank is to be served by at least one fixed mean of discharging and stripping. In addition, arrangements are to

be adopted to make discharge by pumps in the oil terminal possible, taking into account the NPSHD at the pumps, or a second separate fixed mean of discharging is to be fitted.

3.2.2 Use of cargo pumps (1/5/2013)

- a) Except where expressly permitted in [2.2] and [2.3], cargo pumps are to be used exclusively for handling the liquid cargo.
- b) Subject to their performance, cargo pumps may be used for tank stripping.
- c) Cargo pumps may be used, where necessary, for the washing of cargo tanks.

3.2.3 Cargo pump drive (1/5/2013)

Pumps with a submerged electric motor are not permitted in cargo tanks.

Note 1: The provisions of this requirement also apply to stripping pumps and ballast pumps.

3.2.4 Design of cargo pumps (1/5/2013)

- a) Materials of cargo pumps are to be suitable for the products carried.
- b) The delivery side of cargo pumps is to be fitted with relief valves discharging back to the suction side of the pumps (bypass) in closed circuit. Such relief valves may be omitted in the case of centrifugal pumps with a maximum delivery pressure not exceeding the design pressure of the piping, with the delivery valve closed.

3.2.5 Monitoring of cargo pumps (1/5/2013)

Cargo pumps are to be monitored as required in Tab 2.

3.2.6 Control of cargo pumps (1/5/2013)

Cargo pumps are to be capable of being stopped from:

- a position outside the pump room, and
- a position next to the pumps.

3.3 Cargo piping design

3.3.1 General (1/5/2013)

- a) Unless otherwise specified, cargo piping is to be designed and constructed according to the requirements of Pt C, Ch 1, Sec 10 applicable to piping systems of Class III.
- b) For tests, refer to [6].

3.3.2 Materials (1/5/2013)

- a) Cargo piping is, in general, to be made of steel or cast iron.
- b) Valves, couplings and other end fittings of cargo pipe lines for connection to hoses are to be of steel or other suitable ductile material.
- c) Spheroidal graphite cast iron may be used for cargo oil piping.
- d) Grey cast iron may be accepted for cargo oil lines:
 - within cargo tanks, and
 - on the weather deck for pressure up to 1,6 MPa.
 It is not to be used for manifolds and their valves of fittings connected to cargo handling hoses.
- e) Plastic pipes may be used in the conditions specified in Pt C, Ch 1, App 3. Arrangements are to be made to avoid the generation of static electricity.

3.3.3 Connection of cargo pipe lengths (1/5/2013)

Cargo pipe lengths may be connected either by means of welded joints or, unless otherwise specified, by means of flange connections.

3.3.4 Expansion joints (1/5/2013)

- a) Where necessary, cargo piping is to be fitted with expansion joints or bends.
- b) Expansion joints including bellows are to be of a type approved by the Society.
- c) Expansion joints made of non-metallic material may be accepted only inside tanks and provided they are:
 - of an approved type
 - designed to withstand the maximum internal and external pressure
 - electrically conductive
 - sliding type couplings are not to be used for expansion purposes where lines for cargo oil pass through tanks for segregated ballast.

3.3.5 Valves with remote control (1/5/2013)

- a) Valves with remote control are to comply with Pt C, Ch 1, Sec 10, [2.7.3].
- b) Submerged valves are to be remote controlled. In the case of a hydraulic remote control system, control boxes are to be provided outside the tank, in order to permit the emergency control of valves.
- c) Valve actuators located inside cargo tanks are not to be operated by means of compressed air.

Table 2 : Monitoring of cargo pumps (1/5/2013)

Equipment, parameter	Alarm	Indication (1)	Comments
pump, discharge pressure		L	<ul style="list-style-type: none"> • on the pump (2), or • next to the unloading control station
(1) L = low (2) and next to the driving machine if located in a separate compartment			

3.3.6 Cargo hoses (1/5/2013)

- Cargo hoses are to be of a type approved by the Society for the intended conditions of use.
- Hoses subject to tank pressure or pump discharge pressure are to be designed for a bursting pressure not less than 4 times the maximum pressure under cargo transfer conditions.
- The ohmic electrical resistance of cargo hoses is not to exceed $10^6 \Omega$.

3.4 Cargo piping arrangement and installation

3.4.1 Cargo pipes passing through tanks or compartments (1/5/2013)

- Cargo piping and similar piping to cargo tanks is not to pass through ballast tanks except in the case of short lengths of piping complying with [2.1.3], item b).
- Cargo piping may pass through vertical fuel oil tanks adjacent to cargo tanks on condition that the provisions of [2.1.3], item b) are complied with.
- Piping through cargo tanks, see also Sec 2, [3.1.4].

3.4.2 Cargo piping passing through bulkheads (1/5/2013)

Cargo piping passing through bulkheads is to be so arranged as to preclude excessive stresses at the bulkhead. Bolted flanges are not to be used in the bulkhead.

3.4.3 Valves (1/5/2013)

- Stop valves are to be provided to isolate each tank.
- A stop valve is to be fitted at each end of the cargo manifold.
- When a cargo pump in the cargo pump room serves more than one cargo tank, a stop valve is to be fitted in the cargo pump room on the line leading to each tank.
- Main cargo oil valves located in the cargo pump room below the floor gratings are to be remote controlled from a position above the floor.

3.4.4 Draining of cargo pumps and oil lines (1/5/2013)

Every oil carrier and asphalt carrier required to be provided with segregated ballast tanks is to comply with the following requirements:

- it is to be equipped with oil piping so designed and installed that oil retention in the lines is minimised, and
- means are to be provided to drain all cargo pumps and all oil lines at the completion of cargo discharge, where necessary by connection to a stripping device. The line and pump drainings are to be capable of being discharged both ashore and to a cargo tank or slop tank. For discharge ashore, a special small diameter line having a cross-sectional area not exceeding 10% of the main cargo discharge line is to be provided and is to be connected on the downstream side of the carrier's deck

manifold valves, both port and starboard, when the cargo is being discharged; see Fig 1.

Figure 1 : Connection of small diameter line to the manifold valve

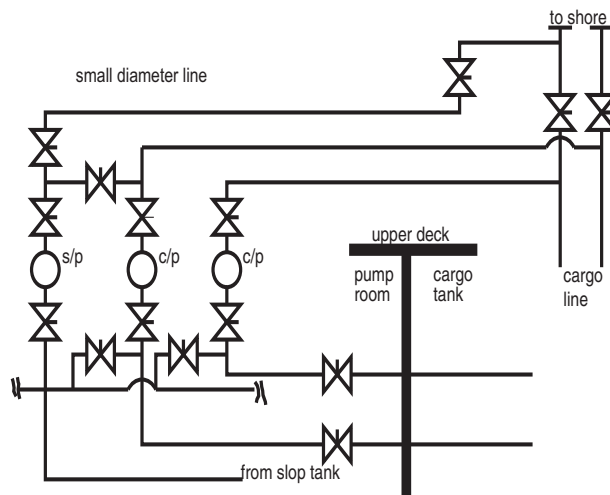

3.5 Integrated cargo and ballast systems design

3.5.1 Functional requirements (1/5/2013)

The operation of cargo and/or ballast systems may be necessary, under certain emergency circumstances or during the course of navigation, to enhance the safety of carriers.

As such, measures are to be taken to prevent cargo and ballast pumps becoming inoperative simultaneously due to a single failure in the integrated cargo and ballast system, including its control and safety systems. The same criteria apply to control systems of cargo and ballast valves.

3.5.2 Design features (1/5/2013)

The following design features are, inter alia, to be fitted:

- the emergency stop circuits of the cargo and ballast systems are to be independent from the circuits for the control systems. A single failure in the control system circuits or the emergency stop circuits is not to render the integrated cargo and ballast system inoperative;
- manual emergency stops of the cargo pumps are to be arranged such that they do not cause the shutdown of the power pack making ballast pumps inoperative;
- the control systems are to be provided with backup power supply, which may be satisfied by a duplicate power supply from the main switchboard. The failure of any power supply is to provide audible and visible alarm activation at each location where the control panel is fitted.
- in the event of failure of the automatic or remote control systems, a secondary means of control is to be made available for the operation of the integrated cargo and ballast system. This is to be achieved by manual overriding and/or redundant arrangements within the control systems.

4 Cargo tanks and fittings

4.1 Application

4.1.1 (1/5/2013)

The provisions of [4] apply to cargo tanks and slop tanks.

4.2 Cargo tank venting

4.2.1 (1/5/2013)

The relevant provisions of Pt C, Ch 1, Sec 10, [9] and Pt C, Ch 1, Sec 10, [11] are to be complied with.

Tank venting systems are to open to the atmosphere at a height of at least 760 mm above the weather deck.

Tanks may be fitted with venting systems of the open type provided with a flame screen. For ships carrying bulk cargoes with flashpoint > 100°C, the flame screen may be omitted.

4.3 Protection against tank overload

4.3.1 General (1/5/2013)

- a) Provisions are to be made to guard against liquid rising in the venting system of cargo or slop tanks to a height which would exceed the design head of the tanks. This is to be accomplished by high level alarms or overflow control systems or other equivalent means, together with gauging devices and cargo tank filling procedures.
- b) Sufficient ullage is to be left at the end of tank filling to permit free expansion of liquid during carriage.
- c) High level alarms, overflow control systems and other means referred to in a) are to be independent of the gauging systems.

4.3.2 High level alarms (1/5/2013)

- a) High level alarms are to be type approved.
- b) High level alarms are to give an audible and visual signal at the cargo control station, where provided.

4.3.3 Other protection systems (1/5/2013)

- a) Where the tank level gauging systems, cargo and ballast pump control systems and valve control systems are centralised in a single location, the provisions of [4.3.1] may be complied with by the fitting of a level gauge for the indication of the end of loading, in addition to that required for each tank. The readings of both gauges for each tank are to be as near as possible to each other and so arranged that any discrepancy between them can be easily detected.
- b) Where a tank can be filled only from other tanks, the provisions of [4.3.1] are considered as complied with.

4.4 Tank washing systems

4.4.1 General (1/5/2013)

- a) Adequate means are to be provided for cleaning the cargo tanks except on units which:
 - are dedicated to the same type of cargo for many consecutive voyages, and
 - are arranged with segregated ballast tanks, and
 - do not carry out tank washing on a regular basis, and
 - use shore services for tank washing and disposal of washing media and residues, when needed.

4.4.2 Washing machines (1/5/2013)

- a) Tank washing machines are to be of a type approved by the Society.
- b) Washing machines are to be made of steel or other electricity conducting materials with a limited propensity to produce sparks on contact.

4.4.3 Washing pipes (1/5/2013)

Washing pipes are to be built, fitted, inspected and tested in accordance with the applicable requirements of Pt C, Ch 1, Sec 10, depending on the kind of washing fluid or water.

4.4.4 Installation of washing systems (1/5/2013)

Tank cleaning openings are not to be arranged in enclosed spaces.

5 Prevention of pollution by cargo oil

5.1 General

5.1.1 Application (1/5/2013)

Unless otherwise specified, the provisions of [5.2] and [5.3] apply only to oil carriers of 150 gross tonnage and above.

5.1.2 Provisions for oil carriers of less than 150 gross tonnage (1/5/2013)

The control of discharge for **oil carriers** of less than 150 gross tonnage is to be effected by the retention of oil on board with subsequent discharge of all contaminated washings to reception facilities unless adequate arrangements are made to ensure that the discharge of any effluent into the sea, where allowed, is effectively monitored to ensure that the total quantity of oil discharged into the sea does not exceed 1/30 000 of the total quantity of the particular cargo of which the residue formed a part.

5.1.3 Exemptions (1/5/2013)

The provisions of [5.2] and [5.3] may be waived in the following cases:

- oil carriers engaged exclusively on voyages within 50 miles from the nearest land and of 72 hours or less in duration and limited to trades between ports or terminals agreed by the Society, provided that oily mixtures are retained on board for subsequent discharge to reception facilities
- oil carriers carrying products which through their physical properties inhibit effective product/water separation and monitoring, for which the control of discharge is to

be effected by the retention of residues on board with discharge of all contaminated washings to reception facilities

5.2 Retention of oil on board

5.2.1 General (1/5/2013)

Adequate means are to be provided for transferring the dirty ballast residue and tank washings from the cargo tanks into a slop tank approved by the Society.

5.2.2 Capacity of slop tanks (1/5/2013)

The arrangement of the slop tank or combination of slop tanks is to have a capacity necessary to retain the slop generated by tank washings, oil residues and dirty ballast residues. The total capacity of the slop tank or tanks is not to be less than 3% of the oil carrying capacity of the ship, except that the Society may accept:

- a) 2% for oil carriers where the tank washing arrangements are such that once the slop tank or tanks are charged with washing water, this water is sufficient for tank washing and, where applicable, for providing the driving fluid for eductors, without the introduction of additional water into the system
- b) 2% where segregated ballast tanks are provided. This capacity may be further reduced to 1,5% for oil tankers where the tank washing arrangements are such that once the slop tank or tanks are charged with washing water, this water is sufficient for tank washing and, where applicable, for providing the driving fluid for eductors, without introduction of additional water into the system.
- c) Slop tanks of any size, including absence of dedicated slop tanks, for units which:
 - are dedicated to the same type of cargo for many consecutive voyages, and
 - are arranged with segregated ballast tanks, and
 - do not carry out tank washing on a regular basis.

5.2.3 Design of slop tanks (1/5/2013)

Slop tanks are to be so designed particularly in respect of the position of inlets, outlets, baffles or weirs where fitted, as to avoid excessive turbulence and entrainment of oil or emulsion with the water.

5.3 Pumping, piping and discharge arrangements

5.3.1 Discharge manifold (1/5/2013)

In every oil carrier, a discharge manifold for connection to reception facilities for the discharge of dirty ballast water or oil contaminated water is to be located on the open deck on both sides of the ship.

5.3.2 Discharge pipelines (1/5/2013)

In every oil carrier, pipelines for the discharge of ballast water or oil contaminated water from cargo tank areas to

the sea, where permitted, are to be led to the open deck or to the ship side above the waterline in the deepest ballast condition, except that:

- a) segregated ballast and clean ballast may be discharged below the waterline:
 - in ports or at offshore terminals, or
 - at sea by gravity,

provided that the surface of the ballast water has been examined immediately before the discharge to ensure that no contamination with oil has taken place.

- b) on every oil carrier at sea, dirty ballast water or oil contaminated water from tanks in the cargo area, other than slop tanks, may be discharged by gravity below the waterline, provided that sufficient time has elapsed in order to allow oil/water separation to have taken place and the water ballast has been examined immediately before the discharge with an oil/water interface detector, in order to ensure that the height of the interface is such that the discharge does not involve any increased risk of harm to the marine environment.

5.3.3 Discharge stopping (1/5/2013)

Means are to be provided for stopping the discharge into the sea of ballast water or oil contaminated water from cargo tank areas, other than those discharges below the waterline permitted under [5.3.2], from a position on the upper deck or above located so that the manifold in use referred to in [5.3.1] and the discharge to the sea from the pipelines referred to in [5.3.1] may be visually observed. Means for stopping the discharge need not be provided at the observation position if a positive communication system such as a telephone or radio system is provided between the observation position and the discharge control position.

5.3.4 Cargo piping connections to sea chests (1/5/2013)

Where a sea chest is permanently connected to the cargo pipeline system, it is to be equipped with both a sea chest valve and an inboard isolation valve. In addition to these valves, the sea chest is to be capable of isolation from the cargo piping system whilst the carrier is loading, transporting or discharging cargo by use of a positive means that is to the satisfaction of the Society. Such a positive means is a facility that is installed in the pipeline system in order to prevent the section of pipeline between the sea chest valve and the inboard valve being filled with cargo under all circumstances.

Examples of positive means may take the form of blanks, spectacle blanks, pipeline blinds, evacuation or vacuum systems, or air or water pressure systems. In the event that evacuation or vacuum systems, or air or water pressure systems are used, then they are to be equipped with both a pressure gauge and alarm system to enable the continuous monitoring of the status of the pipeline section, and thereby the valve integrity, between the sea chest and inboard valves.

6 Certification, inspection and testing

6.1 Application

6.1.1 (1/5/2013)

The provisions of this Article are related to cargo piping and other equipment fitted in the cargo area. They supplement those given in Pt C, Ch 1, Sec 10, [21] for piping systems.

6.2 Workshop tests

6.2.1 Tests for materials (1/5/2013)

Where required in Tab 3, materials used for pipes, valves and fittings are to be subjected to the tests specified in Pt C, Ch 1, Sec 10, [21.3.2].

6.2.2 Hydrostatic testing (1/5/2013)

- Where required in Tab 3, cargo pipes, valves, fittings and pump casings are to be submitted to hydrostatic tests in accordance with the relevant provisions of Pt C, Ch 1, Sec 10, [21.4].
- Expansion joints and cargo hoses are to be submitted to hydrostatic tests in accordance with the relevant provisions of Pt C, Ch 1, Sec 10, [20.4]
- Where fitted, bellow pieces of gas-tight penetration glands are to be pressure tested

6.2.3 Tightness tests (1/5/2013)

Tightness of the following devices is to be checked:

- gas-tight penetration glands
- cargo tank P/V and high velocity valves.

Note 1: These tests may be carried out in the workshops or on board.

6.2.4 Check of the safety valves setting (1/5/2013)

The setting pressure of the pressure/vacuum valves is to be checked in particular with regard to Sec 4, [4.2.6].

6.2.5 Summary table (1/5/2013)

Inspections and tests required for cargo piping and other equipment fitted in the cargo area are summarised in Tab 3.

6.3 Shipboard tests

6.3.1 Pressure test (1/5/2013)

After installation on board, the cargo piping system is to be checked for leakage under operational conditions.

6.3.2 Survey of pollution prevention equipment (1/5/2013)

Every oil carriers of 150 gross tonnage and above is to be subjected to an initial survey before the ship is put in service, to ensure that the equipment, systems, fittings, arrangements and materials fully comply with the relevant provisions of [4.4] and [5].

Table 3 : Inspection and testing at works (1/5/2013)

No.	Item	Tests for materials		Inspections and tests for the products			References
		Y/N (1)	Type of material certificate (2)	during manufacturing (1)	after completion (1) (3)	Type of product certificate (2)	
1	expansion joints and cargo hoses	Y (5)	W	N	Y	C	[6.2.1] [6.2.2]
2	cargo pumps	Y	W	Y (6)	Y	C	see note (6) [6.2.2]
3	gas-tight penetration glands	N		N	Y	C	[6.2.1], [6.2.3]

(1) Y = required, N = not required.

(2) C = class certificate, W = works' certificate.

(3) includes the checking of the rule characteristics according to the approved drawings.

(4) only in the case of welded construction.

(5) if metallic.

(6) inspection during manufacturing is to be carried out according to a program approved by the Society.

No.	Item	Tests for materials		Inspections and tests for the products			References
		Y/N (1)	Type of material certificate (2)	during manufacturing (1)	after completion (1) (3)	Type of product certificate (2)	
4	cargo tank P/V and high velocity valves	Y	C	Y	Y	C	[6.2.1] [6.2.2] (4) [6.2.3] [6.2.4]
5	flame arresters	N		N	Y	C	see note (3)
<p>(1) Y = required, N = not required. (2) C = class certificate, W = works' certificate. (3) includes the checking of the rule characteristics according to the approved drawings. (4) only in the case of welded construction. (5) if metallic. (6) inspection during manufacturing is to be carried out according to a program approved by the Society.</p>							

SECTION 6

ELECTRICAL INSTALLATIONS

1 General

1.1 Application

1.1.1 (1/5/2013)

The requirements in this Section apply, in addition to those contained in Part C, Chapter 2, to ships with the service notation oil carrier.

1.2 Documentation to be submitted

1.2.1 (1/5/2013)

In addition to the documentation requested in Pt C, Ch 2, Sec 1, Tab 1, the following are to be submitted for approval:

- a) plan of hazardous areas
- b) document giving details of types of cables and safety characteristics of the equipment installed in hazardous areas
- c) diagrams of tank level indicator systems, high level alarm systems and overflow control systems where requested.

1.3 System of supply

1.3.1 (1/5/2013)

Earthed systems with hull return are not permitted, with the following exceptions to the satisfaction of the Society:

- a) impressed current cathodic protective systems
- b) limited and locally earthed systems, such as starting and ignition systems of internal combustion engines, provided that any possible resulting current does not flow directly through any hazardous area
- c) insulation level monitoring devices, provided that the circulation current of the device does not exceed 30 mA under the most unfavourable conditions
- d) intrinsically safe systems.

1.3.2 (1/5/2013)

In insulated distribution systems, no current carrying part is to be earthed, other than:

- a) through an insulation level monitoring device
- b) through components used for the suppression of interference in radio circuits.

1.3.3 (1/5/2013)

The additional limitations in the choice of the system of supply (type of distribution system) as per SOLAS Ch.II-1 Reg. 45.4.3 apply to ships subject to the SOLAS Convention.

1.4 Electrical equipment

1.4.1 (1/5/2013)

Electrical equipment, cables and wiring are not to be installed in hazardous locations unless they conform with standards not inferior to those given in IEC 60092-502 Standard.

However, for locations not covered by such standards, electrical equipment, cables and wiring which do not conform to the standards may be installed in hazardous locations based on a risk assessment to the satisfaction of the Society, to ensure that an equivalent level of safety is assured.

1.5 Earth detection

1.5.1 (1/5/2013)

For both insulated and earthed distribution systems a device, or devices, are to be installed to continuously monitor the insulation to earth and to give an audible and visual alarm at a manned position in the event of an abnormally low level of insulation resistance and/or high level of leakage current.

The above is not applicable to systems mentioned in [1.3.1].

1.6 Precautions against inlet of gases or vapours

1.6.1 (1/5/2013)

Suitable arrangements are to be provided, to the satisfaction of the Society, so as to prevent the possibility of gases or vapours passing from a gas-dangerous space to another space through runs of cables or their conduits.

1.7 Electrical equipment permitted in hazardous areas

1.7.1 (1/5/2013)

Electrical equipment permitted in hazardous areas is that indicated in Pt C, Ch 2, Sec 3, [10.1.4], Pt C, Ch 2, Sec 3, [10.1.5], and Pt C, Ch 2, Sec 3, [10.1.6].

1.7.2 In addition to the requirements of [1.7.1], in Zone 1 and Zone 2 the installation of the following is permitted:

hull fittings containing the terminals or shell plating penetrations for anodes or electrodes of an impressed current cathodic protection system, or transducers such as those for depth sounding or log systems, provided that such fittings are of gas-tight construction or housed within a gas-tight enclosure, and are not located adjacent to a cargo tank bulkhead. The design of such fittings or their enclosures and the means by which cables enter, as well as any testing to establish their gas-tightness, are to be to the satisfaction of the Society. The associated cables are to be protected by means of heavy gauge steel pipes with gas-tight joints.

1.7.3 (1/5/2013)

The explosion group and temperature class of electrical equipment of a certified safe type are to be at least IIA and T3 in the case of ships arranged for the carriage of crude oil or other petroleum products.

Other characteristics may be required for dangerous products other than those above.

1.7.4 (1/5/2013)

Enclosed or semi-enclosed spaces (not containing a source of hazard) having a direct opening, including those for ventilation, into any hazardous area, are to be designated as the same hazardous zone as the area in which the opening is located.

Electrical installations are to comply with the requirements for the space or area into which the opening leads.

Note 1: For openings, access and ventilation conditions affecting the extent of hazardous areas, see IEC Standard 60092-502.

2 Special requirements for oil carriers carrying flammable liquids having a flash point not exceeding 60°C**2.1 Hazardous area classification****2.1.1 (1/5/2013)**

For hazardous area classification see Tab 1.

3 Special requirements for oil carrier carrying flammable liquids having a flash point exceeding 60°C**3.1 Hazardous area classification****3.1.1 (1/5/2013)**

For hazardous area classification see Tab 2.

3.2 Cargoes heated to a temperature above their flash point and cargoes heated to a temperature within 15°C of their flash point**3.2.1 (1/5/2013)**

The requirements under [2] apply.

Table 1 : Classification of hazardous areas for oil carriers carrying flammable liquids having a flash point not exceeding 60°C (1/5/2013)

Spaces		Hazardous area
N.	Description	
1	Interior of cargo tanks, slop tanks, any pipework of pressure relief or other venting systems for cargo and slop tanks, pipes and equipment containing cargo or developing flammable gases or vapours.	Zone 0
2	Void spaces adjacent to, above or below integral cargo tanks.	Zone 1
3	Hold spaces containing independent cargo tanks.	Zone 1
4	Cofferdams and permanent (for example, segregated) ballast tanks adjacent to cargo tanks.	Zone 1
5	Cargo pump rooms.	Zone 1
6	Enclosed or semi-enclosed spaces immediately above cargo tanks (e.g. 'tweendecks) or having bulkheads above and in line with cargo tank bulkheads, unless protected by a diagonal plate acceptable to the Society.	Zone 1
7	Spaces other than cofferdams, adjacent to and below the top of a cargo tank (e.g. trunks, passageways and holds) as well as double bottoms and pipe tunnels below cargo tanks.	Zone 1
8	Areas on open deck, or semi-enclosed spaces on open deck, within 3 m of any cargo tank outlet, gas or vapour outlet, cargo manifold valve, cargo valve, cargo pipe flange, cargo pump room ventilation outlets and cargo tank openings for pressure release provided to permit the flow of small volumes of gas or vapour mixtures caused by thermal variation.	Zone 1
9	Areas on open deck, or semi-enclosed spaces on open deck above and in the vicinity of any cargo gas outlet intended for the passage of large volumes of gas or vapour mixture during cargo loading and ballasting or during discharging, within a vertical cylinder of unlimited height and 6m radius centred upon the centre of the outlet, and within a hemisphere of 6m radius below the outlet.	Zone 1
10	Areas on open deck, or semi-enclosed spaces on open deck, within 1,5m of cargo pump room entrances, cargo pump room ventilation inlets, openings into cofferdams or other Zone 1 spaces.	Zone 1
11	Areas on open deck within spillage coamings surrounding cargo manifold valves and 3 m beyond these, up to a height of 2,4 m above the deck.	Zone 1

Spaces		Hazardous area
N.	Description	
12	Areas on open deck over all cargo tanks (including all ballast tanks within the cargo tank area) where structures are restricting the natural ventilation and to the full breadth of the ship plus 3m fore and aft of the forward-most and aft-most cargo tank bulkhead, up to a height of 2,4m above the deck.	Zone 1
13	Compartments for cargo hoses.	Zone 1
14	Enclosed or semi-enclosed spaces in which pipes containing cargoes are located.	Zone 1
15	Areas 2m beyond the area defined in item 8.	Zone 2
16	Areas of 1,5 m surrounding open or semi-enclosed spaces of Zone 1.	Zone 2
17	Areas 4m beyond the cylinder and 4m beyond the sphere defined in item 9.	Zone 2
18	Areas on open deck extending to the coamings fitted to keep any spills on deck and away from the accommodation and service areas and 3m beyond these up to a height of 2,4m above the deck.	Zone 2
19	Areas on open deck over all cargo tanks (including all ballast tanks within the cargo tank area) where unrestricted natural ventilation is guaranteed and to the full breadth of the ship plus 3m fore and aft of the forward-most and aft-most cargo tank bulkhead, up to a height of 2,4m above the deck surrounding open or semi-enclosed spaces of Zone 1.	Zone 2
20	Spaces forward of the open deck areas to which reference is made in item 12 and item 18, below the level of the main deck, and having an opening on the main deck or at a level less than 0,5m above the main deck, unless: a) the entrances to such spaces do not face the cargo tank area and, together with all other openings to the spaces, including ventilation system inlets and exhausts, are situated at least 5m from the fore-most cargo tank and at least 10m measured horizontally from any cargo tank outlet or gas or vapour outlet; and b) the spaces are mechanically ventilated.	Zone 2

Table 2 : Hazardous areas classification for oil carriers carrying flammable liquids having a flash point exceeding 60°C unheated or heated to a temperature below and not within 15°C of their flash point (1/5/2013)

Spaces		Hazardous area
No.	Description	
1	Interior of cargo tanks, slop tanks, any pipework of pressure relief or other venting systems for cargo and slop tanks, pipes and equipment containing cargo.	Zone 2

PALM OIL CARRIERS - ASSISTED PROPULSION

- SECTION 1 GENERAL**
- SECTION 2 SHIP ARRANGEMENT**
- SECTION 3 STABILITY**
- SECTION 4 MACHINERY AND CARGO SYSTEMS**
- SECTION 5 ELECTRICAL INSTALLATIONS**

SECTION 1

GENERAL

1 General

1.1 Application

1.1.1 Service notation palm oil carrier (1/5/2013)

a) The requirements of this Chapter apply to ships having the service notations palm oil carrier, as defined in Pt A, Ch 1, Sec 2, [4.5.2]

As indicated in Pt A, Ch 1, Sec 2, [4.5.11] these units are to be assigned with the additional service feature **assisted propulsion**.

Note 1: As recalled in Part A, Chapter 1, Sec 1, [3.1.1], the classification of a ship does not absolve the Interested Party from compliance with any requirements issued by Administrations and any other applicable international and national regulations for the safety of life at sea and protection of the marine environment.

b) The substances the carriage in bulk of which is covered by the service notations

- **palm oil carrier**
are limited to Palm Oil, carried at a temperature below and not within 15°C of the flashpoint.

1.2 Summary tables

1.2.1 (1/5/2013)

Tab 1 indicates, for easy reference, the Sections or Appendixes of this Chapter dealing with requirements applicable to ships having the service notation:

- **Palm oil carrier**

Table 1 : Sections or Appendixes with requirements applicable to ships having the Service Notation Palm oil carrier (1/5/2013)

Main subject	Reference
Ship arrangement	Sec 2
Hull and stability	Sec 3
Machinery and cargo system	Sec 4
Electrical installations	Sec 5
Automation	(1)
Fire protection, detection and extinction	(1)
(1) No specific requirements are given in this Chapter.	

1.3 Definitions

1.3.1 Cargo area (1/5/2013)

The cargo area is that part of the ship that contains cargo tanks as well as slop tanks, cargo pump rooms including pump rooms, cofferdams, ballast or void spaces adjacent to

cargo tanks or slop tanks as well as deck areas throughout the entire length and breadth of the part of the ship above these spaces.

When independent tanks are installed in hold spaces, the cofferdams, ballast or void spaces at the after end of the aftermost hold space or at the forward end of the forwardmost hold space are excluded from the cargo area.

1.3.2 Cargo pump room (1/5/2013)

Cargo pump room is a space containing pumps and their accessories for the handling of products covered by the service notation granted to the ship.

1.3.3 Cargo service spaces (1/5/2013)

Cargo service spaces are spaces within the cargo area used for workshops, lockers and storerooms of more than 2 m² in area, intended for cargo handling equipment.

1.3.4 Clean ballast (1/5/2013)

Clean ballast means the ballast in a tank which since oil was last carried therein, has been so cleaned that the effluent therefrom if it were discharged from a ship which is stationary into clean calm water on a clear day would not produce visible traces of oil on the surface of the water or on adjoining shorelines or cause a sludge or emulsion to be deposited beneath the surface of the water or upon adjoining shorelines. If the ballast is discharged through an oil discharge monitoring and control system approved by the Society, evidence based on such a system to the effect that the oil content of the effluent did not exceed 15 parts per million is to be determinative that the ballast was clean, notwithstanding the presence of visible traces.

1.3.5 Hold space (1/5/2013)

Hold space is the space enclosed by the ship's structure in which an independent cargo tank is fitted

1.3.6 Fuel oil (1/5/2013)

Fuel oil means any oil used as fuel in connection with the propulsion and auxiliary machinery of the ship on which such oil is carried.

1.3.7 Integrated cargo and ballast system (1/5/2013)

Integrated cargo and ballast system means any integrated hydraulic and/or electric system used to drive both cargo and ballast pumps (including active control and safety systems and excluding passive components, e.g. piping).

1.3.8 Pump room (1/5/2013)

Pump room is a space, located in the cargo area, containing pumps and their accessories for the handling of ballast and fuel oil, or cargoes other than those covered by the service notation granted to the ship.

1.3.9 Segregated ballast (1/5/2013)

Segregated ballast means the ballast water introduced into a tank which is completely separated from the cargo oil and fuel oil system and which is permanently allocated to the carriage of ballast or to the carriage of ballast or cargoes other than oil or noxious substances as variously defined in Chapter 8.

1.3.10 Slop tank (1/5/2013)

Slop tank means a tank specifically designated for the collection of tank draining, tank washings and other oily mixtures.

1.3.11 Void space (1/5/2013)

Void space is an enclosed space in the cargo area external to a cargo tank, except for a hold space, ballast space, fuel oil tank, cargo pump room, pump room, or any space normally used by personnel.

SECTION 2

SHIP ARRANGEMENT

1 General

1.1 Application

1.1.1 (1/5/2013)

The requirements in Sec 2 apply to single deck ships, integral cargo tanks with machinery aft, double bottom throughout the cargo tank area, double side skin and possible longitudinal bulkheads, or single side skin and one or more longitudinal bulkheads throughout the cargo tank area. The deck may be single or double skin, with or without a trunk.

The application of these requirements to other ship types is to be considered by the Society on a case-by-case basis.

1.1.2 Exemptions (1/5/2013)

The requirements in Pt B, Ch 2, Sec 2, [3], b) and [5] do not apply.

2 General arrangement design

2.1 General

2.1.1 Cofferdams (1/5/2013)

A cofferdam or similar compartment of width not less than 760 mm is to be provided at the aft end of the cargo tank area. Its bulkheads are to extend from keel to deck across the full breadth of the ship.

For the purpose of this requirement, the term "cofferdam" is intended to mean an isolating compartment between two adjacent steel bulkheads or decks. The minimum distance between the two bulkheads or decks is to be sufficient for safe access and inspection.

In order to meet the single failure principle, in the particular case when a corner-to-corner situation occurs, this principle may be met by welding a diagonal plate across the corner.

The cofferdams are also to be constructed so as to enable adequate ventilation.

2.1.2 Cargo segregation (1/5/2013)

Unless expressly provided otherwise, tanks containing cargo or cargo residues are to be segregated from accommodation, service and machinery spaces, drinking water and stores for human consumption by means of a cofferdam, or any other similar compartment (see Fig 1).

Figure 1 (1/5/2013)

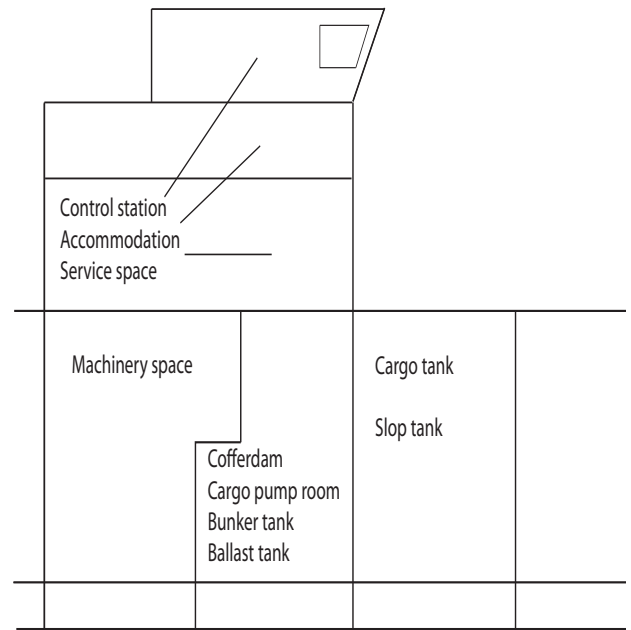

2.1.3 Deck spills (1/5/2013)

Means are to be provided to keep deck spills away from the accommodation and service areas. This may be accomplished by providing a permanent continuous coaming of a suitable height extending from side to side.

2.2 Double bottom tanks or compartments

2.2.1 General (1/5/2013)

Double bottom tanks adjacent to cargo tanks may not be used as fuel oil tanks.

2.2.2 Palm Oil carriers of 5000 t deadweight and above (1/5/2013)

- At any cross-section, the depth of each double bottom tank or compartment is to be such that the distance h between the bottom of the cargo tanks and the moulded line of the bottom shell plating measured at right angles to the bottom shell is not less than $B/15$, in m, with a minimum value of 0,76 m.
- In the turn of the bilge area and at locations without a clearly defined turn of the bilge, the cargo tank boundary line is to run parallel to the line of the midship flat bottom as shown in Fig 3.

3 Size and arrangement of cargo tanks and slop tanks

3.1 Cargo tanks

3.1.1 General (1/5/2013)

Palm oil carriers of 600 t deadweight and above are not allowed to carry cargo in any compartment extending forward of a collision bulkhead located in accordance with Pt B, Ch 2, Sec 1, [2].

3.1.2 Size of cargo tanks (1/5/2013)

The length of each cargo tank is not to exceed 10 metres or one of the values of Tab 1, as applicable, whichever is the greater.

Palm oil carriers are to be provided with cargo tanks so arranged that the capacity of each cargo tank does not exceed 700 m³ unless wing tanks or compartments are arranged, extending either for the full depth of the ship side or from the top of the double bottom to the uppermost deck, disregarding a rounded gunwale where fitted. They are to be arranged such that the cargo tanks are located inboard of the moulded line of the side shell plating,

nowhere less than the distance w which, as shown in Fig 2, is measured at any cross-section at right angles to the side shell, as specified below:

$$w = 0,4 + \frac{2,4DW}{20000} \text{ with a minimum value of } 0,76 \text{ m}$$

DW is the deadweight, in t.

3.1.3 Piping through cargo tanks (1/5/2013)

Lines of piping which run through cargo tanks in a position less than $0,30 B_s$ from the ship's side or less than $0,30 D_s$ from the ship's bottom are to be fitted with valves or similar closing devices at the point at which they open into any cargo tank. These valves are to be kept closed at sea at any time when the tanks contain cargo oil, except that they may be opened only for cargo transfer needed for essential operations.

3.1.4 Suction wells in cargo tanks (1/5/2013)

Suction wells in cargo tanks may protrude into the double bottom below the boundary line defined by the distance h in [2.2.2], provided that such wells are as small as practicable and the distance between the well bottom and bottom shell plating is not less than $0,5 h$.

Figure 2 : Cargo tank boundary lines (1/5/2013)

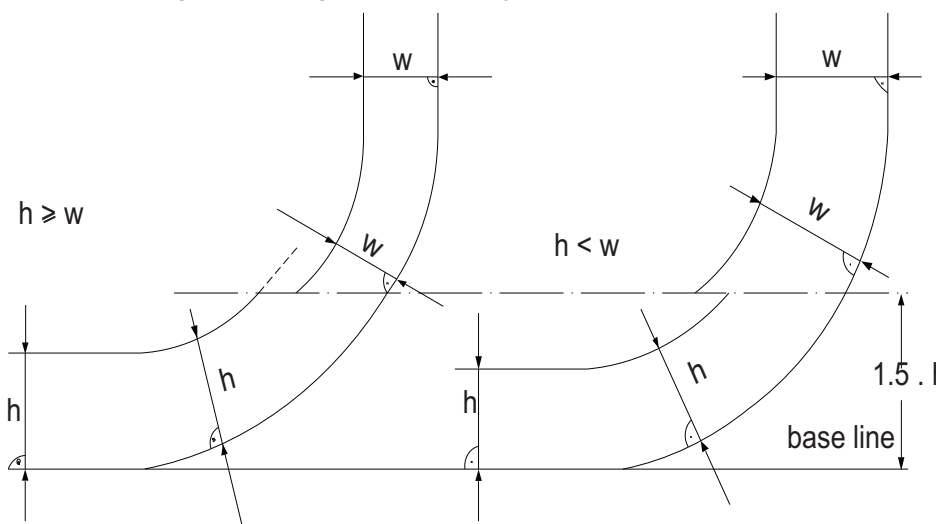
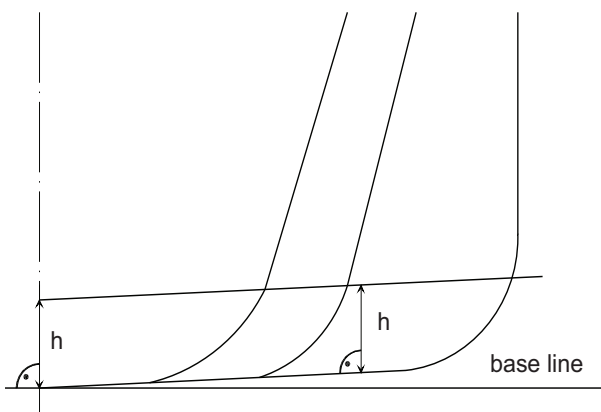

Figure 3 : Cargo tank boundary lines (1/5/2013)



4 Access arrangement

4.1 General

4.1.1 (1/5/2013)

As far as practicable, permanent or movable means of access stored on board are to be provided to ensure proper survey and maintenance of cargo tanks and ballast compartments.

4.1.2 (1/5/2013)

Means of access to side and centre tanks may not be provided in the same transverse section.

Table 1 : Length of cargo tanks (1/5/2013)

Longitudinal bulkhead arrangement	Cargo tank	Condition (1)	Centreline bulkhead arrangement	Length of cargo tanks, in m	
No bulkhead	-	-	-	$(0,5 b_i / B + 0,1) L$ (2)	
Centreline bulkhead	-	-	-	$(0,25 b_i / B + 0,15) L$	
Two or more bulkheads	Wing cargo tank	-	-	0,2 L	
	Centre cargo tank	$b_i / B \geq 1/5$	-	0,2 L	
		$b_i / B < 1/5$	No		$(0,5 b_i / B + 0,1) L$
			Yes		$(0,25 b_i / B + 0,15) L$
(1) b_i is the minimum distance from the ship side to the outer longitudinal bulkhead of the i-th tank, measured inboard at right angles to the centreline at the level corresponding to the assigned summer freeboard.					
(2) Not to exceed 0,2 L					

4.2 Access to pipe tunnel and opening arrangement

4.2.1 Access to the pipe tunnel in the double bottom (1/5/2013)

The pipe tunnel in the double bottom is to comply with the following requirements:

- it may not communicate with the engine room
- provision is to be made for at least two exits to the open deck arranged at a maximum distance from each other. One of these exits fitted with a watertight closure may lead to the cargo pump room.

4.2.2 Doors between pipe tunnel and main pump room (1/5/2013)

Where there is a permanent access from a pipe tunnel to the main pump room, a watertight door is to be fitted complying with the requirements in Pt B, Ch 2, Sec 1, [6.2.1] for watertight doors open at sea and located below the freeboard deck. In addition the following is to be complied with:

- in addition to bridge operation, the watertight door is to be capable of being manually closed from outside the main pump room entrance
- the watertight door is to be kept closed during normal operations of the ship except when access to the pipe tunnel is required. A notice is to be affixed to the door to the effect that it may not be left open.

4.3 Access to compartments in the cargo area

4.3.1 General (1/5/2013)

Access to cofferdams, ballast tanks, cargo tanks and other compartments in the cargo area is to be direct from the open deck and such as to ensure their complete inspection.

Access to double bottom compartments may be through a cargo pump room, pump room, deep cofferdam, pipe tunnel or similar compartments, subject to consideration of ventilation aspects.

4.3.2 Access to the fore peak tank (1/5/2013)

The access to the fore peak tank is to be direct from the open deck.

Alternatively, indirect access from the open deck to the fore peak tank through an enclosed space may be accepted provided that the enclosed space is separated from the cargo tanks by cofferdams or the enclosed space can be well ventilated.

4.3.3 Access through horizontal openings (1/5/2013)

For access through horizontal openings the dimensions are to be sufficient to allow a person wearing a self-contained, air-breathing apparatus and protective equipment to ascend or descend any ladder without obstruction and also to provide a clear opening to facilitate the hoisting of an injured person from the bottom of the compartment. The minimum clear opening is to be not less than 600 mm by 600 mm.

4.3.4 Access through vertical openings (1/5/2013)

For access through vertical openings the minimum clear opening is to be not less than 600 mm by 800 mm at a height of not more than 600 mm from the bottom shell plating unless gratings or other footholds are provided.

4.3.5 Palm oil carriers less than 5000 t deadweight (1/5/2013)

For palm oil carriers of less than 5000 t deadweight smaller dimensions may be approved by the Society in special circumstances, if the ability to traverse such openings or to remove an injured person can be proved to the satisfaction of the Society.

SECTION 3

STABILITY

1 Stability

1.1 Intact stability

1.1.1 General (1/5/2013)

The stability of the ship for the loading conditions in Pt B, Ch 3, App 2, [1.2.6] is to be in compliance with the requirements in Pt B, Ch 3, Sec 2. In addition, the requirements in [1.1.2] are to be complied with.

1.1.2 Liquid transfer operations (1/5/2013)

Ships with certain internal subdivision may be subjected to lolling during liquid transfer operations such as loading, unloading or ballasting. In order to prevent the effect of lolling, the design of oil carriers of 5000 t deadweight and above is to be such that the following criteria are complied with:

a) The intact stability criteria reported in b) is to be complied with for the worst possible condition of loading and ballasting as defined in c), consistent with good operational practice, including the intermediate stages

of liquid transfer operations. Under all conditions the ballast tanks are to be assumed slack.

- b) The initial metacentric height GMO , in m, corrected for free surface measured at 0° heel, is to be not less than 0,15. For the purpose of calculating GMO , liquid surface corrections are to be based on the appropriate upright free surface inertia moment.
- c) The vessel is to be loaded with:
- all cargo tanks filled to a level corresponding to the maximum combined total of vertical moment of volume plus free surface inertia moment at 0° heel, for each individual tank
 - cargo density corresponding to the available cargo deadweight at the displacement at which transverse KM reaches a minimum value
 - full departure consumable
 - 1% of the total water ballast capacity. The maximum free surface moment is to be assumed in all ballast tanks.

SECTION 4

MACHINERY AND CARGO SYSTEMS

1 General

1.1 Application

1.1.1 (1/5/2013)

The requirements of this Section apply to ships having the service notations:

- palm oil carrier

intended to carry palm oil at a temperature below and not within 15°C of the flashpoint.

1.2 Documents to be submitted

1.2.1 (1/5/2013)

The documents listed in Tab 1 are to be submitted for approval in four copies.

2 Piping systems other than cargo piping system

2.1 General

2.1.1 Materials (1/5/2013)

- Materials are to comply with the provisions of Pt C, Ch 1, Sec 10.
- Spheroidal graphite cast iron may be accepted for bilge and ballast piping.

2.1.2 Independence of piping systems (1/5/2013)

Fuel oil systems are to:

- be independent from the cargo piping system
- have no connections with pipelines serving cargo or slop tanks.

2.1.3 Passage through cargo tanks and slop tanks (1/5/2013)

- Unless otherwise specified, bilge, ballast and fuel oil systems serving spaces located outside the cargo area

are not to pass through cargo tanks or slop tanks. They may pass through ballast tanks or void spaces located within the cargo area.

- Where expressly permitted, ballast pipes passing through cargo tanks are to fulfil the following provisions:
 - they are to have welded or heavy flanged joints the number of which is kept to a minimum
 - they are to be of extra-reinforced wall thickness as per Pt C, Ch 1, Sec 10, Tab 5
 - they are to be adequately supported and protected against mechanical damage.

2.2 Bilge system

2.2.1 Draining of spaces located outside the cargo area (1/5/2013)

For bilge draining of spaces located outside the cargo area, refer to Pt C, Ch 1, Sec 10, [6].

2.2.2 Draining of pump rooms (1/5/2013)

- Arrangements are to be provided to drain the pump rooms by means of power pumps or bilge ejectors.

Note 1: On carriers of less than 500 gross tonnage, the pump rooms may be drained by means of hand pumps with a suction diameter of not less than 50 mm.

- Cargo pumps or stripping pumps may be used for draining cargo pump rooms provided that:
 - a screw-down non-return valve is fitted on the bilge suction, and
- Bilge pipe internal diameter is not to be less than 50 mm.
- High liquid level in the bilges is to activate an audible and visual alarm in the cargo control room and on the navigation bridge.

Table 1 : Documents to be submitted (1/5/2013)

No.	Description of the document (1)
1	Diagram of cargo piping system
2	Diagram of the cargo tank venting system with indication of the outlet position
3	Diagram of the cargo tank level gauging system with overfill safety arrangements
4	Diagram of the bilge and ballast systems serving the spaces located in the cargo area
5	Diagram of the cargo heating systems
(1) Diagrams are also to include, where applicable, the (local and remote) control and monitoring systems and automation systems.	

2.2.3 Drainage of hold spaces, cofferdams and void spaces located within the cargo area (1/5/2013)

Hold spaces, cofferdams and void spaces located within the cargo area and not intended to be filled with water ballast are to be fitted with suitable means of drainage.

2.3 Ballast system

2.3.1 General (1/5/2013)

- a) Every Palm oil carrier is to be provided with segregated ballast tanks
- b) The capacity of the segregated ballast tanks is to be considered by the Society on a case-by-case basis. In general, the capacity of segregated ballast tanks is to be at least such that, in any ballast condition at any part of the voyage, including the conditions consisting of light-weight plus segregated ballast only, the ship's draught and trim satisfy minimum and maximum values deemed reasonable by the Society
- c) Except where expressly permitted, ballast systems serving segregated ballast tanks are to be completely separated from the cargo and fuel oil systems.
- d) In palm oil carriers of 150 gross tonnage and above, no ballast water is normally to be carried in any fuel oil tank; see Pt C, Ch 1, Sec 10, [7.1.3].

2.3.2 Pumping arrangements for ballast tanks within the cargo area (1/5/2013)

Segregated ballast tanks located within the cargo area are to be served by two different means. At least one of these means is to be a pump or an eductor used exclusively for dealing with ballast. The ballast system serving the spaces located outside the cargo area may be used for this purpose.

2.3.3 Emergency discharge of segregated ballast (1/5/2013)

Provisions may be made for emergency discharge of the segregated ballast by means of a connection to a cargo pump through a detachable spool piece provided that:

- non-return valves are fitted on the segregated ballast connections to prevent the passage of palm oil to the ballast tank, and
- shut-off valves are fitted to shut off the cargo and ballast lines before the spool piece is removed.

The detachable spool piece is to be placed in a conspicuous position in the pump room and a permanent warning notice restricting its use is to be displayed in a conspicuous position adjacent to it.

2.3.4 Carriage of ballast water in cargo tanks (1/5/2013)

- a) Provisions may be made for filling cargo tanks with sea water, where permitted. Such ballast water is to be dealt with according to [5].
- b) The sea water inlets and overboard discharges serving cargo tanks for the purpose of a) are not to have any

connection with the ballast system of segregated ballast tanks.

- c) Cargo pumps may be used for pumping ballast water to or from the cargo tanks, provided two shut-off valves are fitted to isolate the cargo piping system from the sea inlets and overboard discharges.
- d) Ballast pumps serving segregated ballast tanks may be used for filling the cargo tanks with sea water provided that the connection is made on the top of the tanks and consists of a detachable spool piece and a screw-down non-return valve to avoid siphon effects.

2.3.5 Ballast pipes passing through tanks (1/5/2013)

- a) In palm oil carriers of 600 tonnes deadweight and above, ballast piping is not to pass through cargo tanks except in the case of short lengths of piping complying with [2.1.3], item b).
- b) Sliding type couplings are not to be used for expansion purposes where ballast lines pass through cargo tanks. Expansion bends only are permitted.

2.3.6 Integrated cargo and ballast system (1/5/2013)

The requirements for integrated cargo and ballast systems are given in [3.5].

2.4 Scupper pipes

2.4.1 (1/5/2013)

Scupper pipes are not to pass through cargo tanks except, where this is impracticable, in the case of short lengths of piping complying with the following provisions:

- they are of steel
- they have only welded or heavy flanged joints the number of which is kept to a minimum
- they are of substantial wall thickness as per Pt C, Ch 1, Sec 10, Tab 22, column 1.

2.5 Heating systems intended for cargo

2.5.1 General (1/5/2013)

Heating systems intended for cargo are to comply with the relevant requirements of Pt C, Ch 1, Sec 10.

2.5.2 (1/5/2013)

Heating or cooling media are to be of a type approved for use with the specific cargo.

The surface temperature of heating coils or ducts is to be limited so as to avoid dangerous reactions from localized overheating or overcooling of cargo.

2.5.3 (1/5/2013)

In any heating or cooling system, means shall be provided to ensure that, when in any condition other than empty, a higher pressure can be maintained within the system than the maximum pressure head that could be exerted by the cargo tank contents on the system.

3 Cargo pumping and piping systems

3.1 General

3.1.1 (1/5/2013)

A complete system of pumps and piping is to be fitted for handling the cargo.

3.2 Cargo pumping system

3.2.1 Number and location of cargo pumps (1/5/2013)

Each cargo tank is to be served by at least one fixed mean of discharging. In addition, arrangements are to be adopted to make discharge by pumps in the oil terminal possible, taking into account the NPSHD at the pumps, or a second separate fixed mean of discharging is to be fitted.

3.2.2 Use of cargo pumps (1/5/2013)

- Except where expressly permitted in [2.2] and [2.3], cargo pumps are to be used exclusively for handling the liquid cargo.
- Subject to their performance, cargo pumps may be used for tank stripping.
- Cargo pumps may be used, where necessary, for the washing of cargo tanks.

3.2.3 Cargo pump drive (1/5/2013)

Pumps with a submerged electric motor are not permitted in cargo tanks.

Note 1: The provisions of this requirement also apply to stripping pumps and ballast pumps.

3.2.4 Design of cargo pumps (1/5/2013)

- Materials of cargo pumps are to be suitable for the products carried.
- The delivery side of cargo pumps is to be fitted with relief valves discharging back to the suction side of the pumps (bypass) in closed circuit. Such relief valves may be omitted in the case of centrifugal pumps with a maximum delivery pressure not exceeding the design pressure of the piping, with the delivery valve closed.

3.2.5 Monitoring of cargo pumps (1/5/2013)

Cargo pumps are to be monitored as required in Tab 2.

3.2.6 Control of cargo pumps (1/5/2013)

Cargo pumps are to be capable of being stopped from:

- a position outside the pump room, and
- a position next to the pumps.

3.3 Cargo piping design

3.3.1 General (1/5/2013)

- Unless otherwise specified, cargo piping is to be designed and constructed according to the requirements

of Pt C, Ch 1, Sec 10 applicable to piping systems of class III.

- For tests, refer to Ch 7, Sec 4, [6].

3.3.2 Materials (1/5/2013)

- Cargo piping is, in general, to be made of steel or cast iron.
- Valves, couplings and other end fittings of cargo pipe lines for connection to hoses are to be of steel or other suitable ductile material.
- Spheroidal graphite cast iron may be used for cargo oil piping.
- Grey cast iron may be accepted for cargo oil lines:
 - within cargo tanks, and
 - on the weather deck for pressure up to 1,6 Mpa.

It is not to be used for manifolds and their valves of fittings connected to cargo handling hoses.

- Plastic pipes may be used in the conditions specified in Pt C, Ch 1, App 3. Arrangements are to be made to avoid the generation of static electricity.

3.3.3 Connection of cargo pipe lengths (1/5/2013)

Cargo pipe lengths may be connected either by means of welded joints or, unless otherwise specified, by means of flange connections.

3.3.4 Expansion joints (1/5/2013)

- Where necessary, cargo piping is to be fitted with expansion joints or bends.
- Expansion joints including bellows are to be of a type approved by the Society.
- Expansion joints made of non-metallic material may be accepted only inside tanks and provided they are:
 - of an approved type
 - designed to withstand the maximum internal and external pressure
 - electrically conductive
 - sliding type couplings are not to be used for expansion purposes where lines for cargo oil pass through tanks for segregated ballast.

3.3.5 Valves with remote control (1/5/2013)

- Valves with remote control are to comply with Pt C, Ch 1, Sec 10, [2.7.3].
- Submerged valves are to be remote controlled. In the case of a hydraulic remote control system, control boxes are to be provided outside the tank, in order to permit the emergency control of valves.
- Valve actuators located inside cargo tanks are not to be operated by means of compressed air.

Table 2 : Monitoring of cargo pumps (1/5/2013)

Equipment, parameter	Alarm	Indication (1)	Comments
pump, discharge pressure		L	<ul style="list-style-type: none"> on the pump (2), or next to the unloading control station
(1) L = low			
(2) and next to the driving machine if located in a separate compartment			

3.3.6 Cargo hoses (1/5/2013)

- Cargo hoses are to be of a type approved by the Society for the intended conditions of use.
- Hoses subject to tank pressure or pump discharge pressure are to be designed for a bursting pressure not less than 4 times the maximum pressure under cargo transfer conditions.
- The ohmic electrical resistance of cargo hoses is not to exceed $10^6 \Omega$.

3.4 Cargo piping arrangement and installation**3.4.1 Cargo pipes passing through tanks or compartments (1/5/2013)**

- Cargo piping and similar piping to cargo tanks is not to pass through ballast tanks except in the case of short lengths of piping complying with [2.1.3], item b).
- Cargo piping may pass through vertical fuel oil tanks adjacent to cargo tanks on condition that the provisions of [2.1.3], item b) are complied with.
- Piping through cargo tanks, see also Ch 25, Sec 2, [3.1.3].

3.4.2 Cargo piping passing through bulkheads (1/5/2013)

Cargo piping passing through bulkheads is to be so arranged as to preclude excessive stresses at the bulkhead. Bolted flanges are not to be used in the bulkhead.

3.4.3 Valves (1/5/2013)

- Stop valves are to be provided to isolate each tank.
- A stop valve is to be fitted at each end of the cargo manifold.
- When a cargo pump in the cargo pump room serves more than one cargo tank, a stop valve is to be fitted in the cargo pump room on the line leading to each tank.
- Main cargo valves located in the cargo pump room below the floor gratings are to be remote controlled from a position above the floor.

3.5 Integrated cargo and ballast systems design**3.5.1 Functional requirements (1/5/2013)**

The operation of cargo and/or ballast systems may be necessary, under certain emergency circumstances or during the course of navigation, to enhance the safety of carriers.

As such, measures are to be taken to prevent cargo and ballast pumps becoming inoperative simultaneously due to a

single failure in the integrated cargo and ballast system, including its control and safety systems. The same criteria apply to control systems of cargo and ballast valves.

3.5.2 Design features (1/5/2013)

The following design features are, inter alia, to be fitted:

- the emergency stop circuits of the cargo and ballast systems are to be independent from the circuits for the control systems. A single failure in the control system circuits or the emergency stop circuits is not to render the integrated cargo and ballast system inoperative;
- manual emergency stops of the cargo pumps are to be arranged such that they do not cause the shutdown of the power pack making ballast pumps inoperable;
- the control systems are to be provided with backup power supply, which may be satisfied by a duplicate power supply from the main switchboard. The failure of any power supply is to provide audible and visible alarm activation at each location where the control panel is fitted.
- in the event of failure of the automatic or remote control systems, a secondary means of control is to be made available for the operation of the integrated cargo and ballast system. This is to be achieved by manual overriding and/or redundant arrangements within the control systems.

4 Cargo tanks and fittings**4.1 Application****4.1.1 (1/5/2013)**

The provisions of [4] apply to cargo tanks and slop tanks.

4.2 Cargo tank venting**4.2.1 (1/5/2013)**

The relevant provisions of Pt C, Ch 1, Sec 10, [9] and Pt C, Ch 1, Sec 10, [11] are to be complied with.

Tank venting systems are to open to the atmosphere at a height of at least 760 mm above the weather deck.

Tanks may be fitted with venting systems of the open type.

4.3 Protection against tank overload**4.3.1 General (1/5/2013)**

- Provisions are to be made to guard against liquid rising in the venting system of cargo or slop tanks to a height which would exceed the design head of the tanks. This is to be accomplished by high level alarms or overflow

control systems or other equivalent means, together with gauging devices and cargo tank filling procedures.

- b) Sufficient ullage is to be left at the end of tank filling to permit free expansion of liquid during carriage.
- c) High level alarms, overflow control systems and other means referred to in a) are to be independent of the gauging system.

4.3.2 High level alarms (1/5/2013)

- a) High level alarms are to be type approved.
- b) High level alarms are to give an audible and visual signal at the control station, where provided.

4.3.3 Other protection systems (1/5/2013)

- a) Where the tank level gauging systems, cargo and ballast pump control systems and valve control systems are centralised in a single location, the provisions of [4.3.1] may be complied with by the fitting of a level gauge for the indication of the end of loading, in addition to that required for each tank. The readings of both gauges for each tank are to be as near as possible to each other and so arranged that any discrepancy between them can be easily detected.
- b) Where a tank can be filled only from other tanks, the provisions of [4.3.1] are considered as complied with.

5 Prevention of pollution by palm oil

5.1 General

5.1.1 (1/5/2013)

The control of discharge is to be effected by the retention of oil on board with subsequent discharge of all residues, including contaminated washings if any, to reception facilities.

6 Certification, inspection and testing

6.1 Application

6.1.1 (1/5/2013)

The provisions of this Article are related to cargo piping and other equipment fitted in the cargo area. They supplement those given in Pt C, Ch 1, Sec 10, [21] for piping systems.

6.2 Workshop tests

6.2.1 Tests for materials (1/5/2013)

Where required in Tab 3, materials used for pipes, valves and fittings are to be subjected to the tests specified in Pt C, Ch 1, Sec 10, [21.3.2].

6.2.2 Hydrostatic testing (1/5/2013)

- a) Where required in Tab 3, cargo pipes, valves, fittings and pump casings are to be submitted to hydrostatic tests in accordance with the relevant provisions of Pt C, Ch 1, Sec 10, [21.4].
- b) Expansion joints and cargo hoses are to be submitted to hydrostatic tests in accordance with the relevant provisions of Pt C, Ch 1, Sec 10, [21.4].
- c) Where fitted, bellow pieces of gas-tight penetration glands are to be pressure tested.

6.2.3 Tightness tests (1/5/2013)

Tightness of the following devices is to be checked:

- gas-tight penetration glands
- cargo tank P/V and high velocity valves.

Note 1: These tests may be carried out in the workshops or on board.

6.2.4 Check of the safety valves setting (1/5/2013)

The setting pressure of the pressure/vacuum valves is to be checked in particular with regard to Ch 25, Sec 4, [4.2.6].

6.2.5 Summary table (1/5/2013)

Inspections and tests required for cargo piping and other equipment fitted in the cargo area are summarised in Tab 3.

6.3 Shipboard tests

6.3.1 Pressure test (1/5/2013)

After installation on board, the cargo piping system is to be checked for leakage under operational conditions.

Table 3 : Inspection and testing at works (1/5/2013)

No.	Item	Tests for materials		Inspections and tests for the products			References
		Y/N (1)	Type of material certificate (2)	during manufacturing (1)	after completion (1) (3)	Type of product certificate (2)	
1	expansion joints and cargo hoses	Y (4)	W	N	Y	C	[6.2.1] [6.2.3]
2	cargo pumps	Y	W	Y (5)	Y	C	see note [6.2.3] (5)

(1) Y = required, N = not required.
(2) C = class certificate, W = works' certificate.
(3) includes the checking of the rule characteristics according to the approved drawings.
(4) if metallic
(5) inspection during manufacturing is to be carried out according to a program approved by the Society.

SECTION 5

ELECTRICAL INSTALLATIONS

1 General

1.1 Application

1.1.1 (1/5/2013)

The requirements in this Section apply, in addition to those contained in Part C, Chapter 2, to ships with the service notation **palm oil carrier**.

1.2 Documentation to be submitted

1.2.1 (1/5/2013)

In addition to the documentation requested in Pt C, Ch 2, Sec 1, Tab 1, the following are to be submitted for approval:

- a) plan of hazardous areas
- b) document giving details of types of cables and safety characteristics of the equipment installed in hazardous areas
- c) diagrams of tank level indicator systems, high level alarm systems and overflow control systems where requested.

1.3 System of supply

1.3.1 (1/5/2013)

Earthed systems with hull return are not permitted, with the following exceptions to the satisfaction of the Society:

- a) impressed current cathodic protective systems
- b) limited and locally earthed systems, such as starting and ignition systems of internal combustion engines, provided that any possible resulting current does not flow directly through any hazardous area
- c) insulation level monitoring devices, provided that the circulation current of the device does not exceed 30 mA under the most unfavourable conditions
- d) intrinsically safe systems.

1.3.2 (1/5/2013)

In insulated distribution systems, no current carrying part is to be earthed, other than:

- a) through an insulation level monitoring device
- b) through components used for the suppression of interference in radio circuits.

1.3.3 (1/5/2013)

The additional limitations in the choice of the system of supply (type of distribution system) as per SOLAS Ch.II-1 Reg. 45.4.3 apply to ships subject to the SOLAS Convention.

1.4 Electrical equipment

1.4.1 (1/5/2013)

Electrical equipment, cables and wiring are not to be installed in hazardous locations unless they conform with standards not inferior to those given in IEC 60092-502 Standard.

However, for locations not covered by such standards, electrical equipment, cables and wiring which do not conform to the standards may be installed in hazardous locations based on a risk assessment to the satisfaction of the Society, to ensure that an equivalent level of safety is assured.

1.5 Earth detection

1.5.1 (1/5/2013)

For both insulated and earthed distribution systems a device, or devices, are to be installed to continuously monitor the insulation to earth and to give an audible and visual alarm at a manned position in the event of an abnormally low level of insulation resistance and/or high level of leakage current.

The above is not applicable to systems mentioned in [1.3.1].

1.6 Precautions against inlet of gases or vapours

1.6.1 (1/5/2013)

Suitable arrangements are to be provided, to the satisfaction of the Society, so as to prevent the possibility of gases or vapours passing from a gas-dangerous space to another space through runs of cables or their conduits.

1.7 Electrical equipment permitted in hazardous areas

1.7.1 (1/5/2013)

Electrical equipment permitted in hazardous areas is that indicated in Pt C, Ch 2, Sec 3, [10.1.4], Pt C, Ch 2, Sec 3, [10.1.5], and Pt C, Ch 2, Sec 3, [10.1.6].

1.7.2 (1/5/2013)

In addition to the requirements of [1.7.1], in Zone 1 and Zone 2 the installation of the following is permitted:

hull fittings containing the terminals or shell plating penetrations for anodes or electrodes of an impressed current cathodic protection system, or transducers such as those for depth sounding or log systems, provided that such fittings are of gas-tight construction or housed within a gas-tight enclosure, and are not located adjacent to a cargo tank bulkhead. The design of such fittings or their enclosures and the means by which cables enter, as well as any testing to establish their gas-tightness, are to be to the satisfaction of the Society. The associated cables are to be protected by means of heavy gauge steel pipes with gas-tight joints.

1.7.3 (1/5/2013)

Enclosed or semi-enclosed spaces (not containing a source of hazard) having a direct opening, including those for ventilation, into any hazardous area, are to be designated as the same hazardous zone as the area in which the opening is located.

Electrical installations are to comply with the requirements for the space or area into which the opening leads.

Note 1: For openings, access and ventilation conditions affecting the extent of hazardous areas, see IEC Standard 60092-502.

1.8 Hazardous area classification

1.8.1 (1/5/2013)

For hazardous area classification see Tab 1.

Table 1 : Hazardous areas classification for palm oil carriers (carrying palm oil heated to a temperature below and not within 15°C of the flash point) (1/5/2013)

Spaces		Hazardous area
No.	Description	
1	Interior of cargo tanks, slop tanks, any pipework of pressure relief or other venting systems for cargo and slop tanks, pipes and equipment containing cargo.	Zone 2

UNITS FOR TRANSHIPMENT OF DRY CARGO IN BULK

SECTION 1	GENERAL
SECTION 2	UNIT ARRANGEMENT
SECTION 3	HULL AND STABILITY

SECTION 1

GENERAL

1 General

1.1 Application

1.1.1 (1/7/2014)

The requirements of this Section apply to units having one of the service notations **transhipping unit** or **transhipping floating terminal**, as defined in Pt A, Ch 1, Sec 2, [4.11].

1.1.2 (1/7/2014)

Units dealt with in this Chapter are to comply with the requirements stipulated in Parts A, B, C and D, as applicable, and with the requirements of this Chapter, which are specific to transhipping units or transhipping floating terminals.

1.1.3 (1/7/2014)

Units equipped with permanent mooring arrangements are to comply with the requirements for the assignment of the additional class notation **MOORING**, given in Pt F, Ch 13, Sec 21.

1.1.4 (1/7/2014)

Units provided with at least one crane, fitted with a grab or a bucket, are to comply with the requirements for the assignment of the additional class notation **CARGO HANDLING**, given in Pt A, Ch 1, Sec 2, [6.14.30].

1.2 Summary table

1.2.1 (1/7/2014)

Tab 1 indicates, for ready reference, the Sections of this Chapter containing specific requirements applicable to transhipping units or transhipping floating terminals.

Table 1 (1/7/2014)

Main subject	Reference
Unit arrangement	Sec 2
Hull and stability	Sec 3
Machinery and systems	(1)
Electrical installations	(1)
Automation	(1)
Fire protection, detection and extinction	(1)
(1) No specific requirements for transhipping units or transhipping floating terminals are given in this Chapter.	

SECTION 2

UNIT ARRANGEMENT

1 General

1.1 Application

1.1.1 (1/7/2014)

The requirements of this Section apply to units having one of the service notations **transshipping unit** or **transshipping floating terminal**, as defined in Pt A, Ch 1, Sec 2, [4.11].

1.2 Documents to be submitted

1.2.1 (1/7/2014)

Tab 1 lists the plans or documents that are to be submitted to the Society, as applicable.

Table 1 : Documents to be submitted (1/7/2014)

No.	A/I (1)	Document
1	A	Typical loading and unloading sequences, including conditions with uneven distribution (e.g. part loading conditions with empty cargo holds, as applicable)
2	I	Data regarding properties of cargo (e.g. bulk density, angle of repose, humidity limits, etc.)
3	I	Loading and unloading systems manual
(1) A = to be submitted for approval in four copies I = to be submitted for information in duplicate		

2 Cargo handling arrangements

2.1 General

2.1.1 (1/7/2014)

In compliance with Pt A, Ch 1, Sec 2, [4.11.1], the additional class notation **CARGO HANDLING** is assigned.

The lifting arrangements are to comply with the "Rules for loading and unloading arrangements and for other lifting appliances on board ships or other similar units".

2.1.2 (1/7/2014)

The minimum cargo handling piece of equipment to be fitted on a transshipping unit or a transshipping floating terminal is a crane fitted with a grab or bucket.

2.1.3 (1/7/2014)

The cargo handling cranes, when loaded with the maximum volume of cargo having the maximum allowed density, are to have a minimum outreach (i.e. the extension outboard of the bumper) not greater than 10 meters and a maximum outreach not less than 20 meters; these values may be considered on a case by case basis in the case of units intended for special operations, at the discretion of the Society.

2.1.4 (1/7/2014)

The designer is responsible for the scantlings of specific cargo handling gears like conveyors and similar equipment.

2.1.5 (1/7/2014)

Cargo handling cranes and gears are to be arranged such that cargo does not normally pass over or in close proximity to accommodation and control stations of the unit; the Society may consider alternative arrangements giving an equivalent level of safety in the case of unintentional release of lifted cargo.

2.1.6 (1/7/2014)

Units equipped with one or more cranes fitted with a grab or bucket are assigned the additional class notation **GRAB [X]** and are to comply with the requirements in Pt F, Ch 13, Sec 2, [3].

3 Ship-to-Unit Mooring arrangements

3.1 General

3.1.1 (1/7/2014)

Transshipping units and Transshipping floating terminals are to be fitted with suitable arrangements for mooring; this includes winches, cables, fairleads and mooring cleats but also bumpers, fenders and hull structures.

3.1.2 (1/7/2014)

The mooring analysis is to be carried out considering the range of ships that, according to the design, are intended to be moored with the unit in order to carry out ship-to-unit cargo transfer operations.

3.1.3 (1/7/2014)

A selected sample of representative ships is to be identified, and agreed with the Society, on the basis of which the mooring analysis is to be carried out and the mooring loads are to be calculated, by means of a direct analysis.

In any case, the overall methodology for the ship-to-unit mooring analysis (sample of ships to be considered, model tests, numerical calculations and software verification) is to be agreed with the Society at the first phase of the design.

3.2 Mooring analysis

3.2.1 (1/7/2014)

The following information is to be provided, as a minimum, in order to assess the ship-to-unit mooring analysis:

- description of the mooring system of the unit with the seabed,
- ship-to-unit mooring system:
 - mooring arrangements,
 - detailed description of mooring fittings, mooring lines, fenders (mechanical characteristics and geometrical description),

c) unit:

- loading conditions during ship-to-unit transfer operations,
- characteristics of weight distribution (moments of inertia) in the various loading conditions,

d) for each ship considered in the analysis:

- general characteristics,
- lines plans,
- loading conditions during ship-to-unit transfer operations,
- characteristics of weight distribution (moments of inertia) in the various loading conditions,
- mooring fitting arrangement.

3.2.2 (1/7/2014)

The design limit environmental conditions for ship-to-unit mooring operations are to be specified. The following information on the design marine weather conditions is to be provided for the specific location:

- wave height,
- wave period (range or maximum),
- wave spectrum,
- wind speed,
- current speed,
- directionality information for wind, wave and current.

The data assumed for the mooring analysis are to be consistent with the data provided in the marine weather analysis report. The design performance, in terms of allowable failures of the mooring system, is to be specified by the designer.

3.2.3 (1/7/2014)

The loads on the system caused by the following primary factors are to be taken into account for the mooring analysis:

- static loads (e.g. pretension in mooring lines),
- wind,
- current,
- waves (slow frequency and wave frequency motions).

The analysis is to cover all the most critical cases envisaged, according to the design marine weather conditions for ship-to-unit operations. The effects of wind, current and waves, considered as acting simultaneously, are to be considered, according to [3.2.2].

3.2.4 (1/7/2014)

The analysis is to reproduce, as closely as possible, the actual behaviour of the system during its operative life, considering mechanical and hydrodynamic issues. In general,

fully coupled, nonlinear, time domain simulations are required. Simplifications may be accepted by the Society, on a case by case basis.

Assumptions and simplifications are to be clearly indicated and explained.

A sensitivity analysis is to be performed in order to check the validity of the calculations.

Assessments and calculations considering the allowable failure of mooring fittings and mooring lines are to be carried out, when operations in such conditions are envisaged in the design conditions.

Additional analyses may be required by the Society, when deemed necessary on the basis of the system and unit characteristics.

3.2.5 (1/7/2014)

The Ship-to-unit Mooring Analysis report is to include, at least:

- a detailed description of the software for the calculation and the associated theory,
- a description of the hydrodynamic and mechanical models,
- a calibration and comparison with model tests (or with previous experience, when acceptable),
- RAO's of the vessels motions, with input parameters specification in the case of non-linear/linearized analysis, and Quadratic Transfer Function of the unit,
- environmental data and wind/current combination matrix,
- assumptions and simplifications,
- a description of additional viscous damping, if applicable,
- statistics of the results (motions, velocities, accelerations, tensions on the lines and loads on the fenders),
- spectral analyses of the results,
- time histories of the results.

4 Access on board arrangement

4.1

4.1.1 (1/7/2014)

Transshipping units and Transshipping floating terminals which are intended to be moored alongside, in between of two other ships (e.g. a barge being discharged and a bulk carrier being loaded), are to be fitted with means of access arranged so that they remain available in all operational conditions.

SECTION 3

HULL AND STABILITY

1 Application

1.1

1.1.1 (1/7/2014)

The requirements of this Section apply to units having one of the service notations transshipping unit or transshipping floating terminal, as defined in Pt A, Ch 1, Sec 2, [4.11].

2 Stability

2.1 Intact stability under navigating conditions

2.1.1 Application (1/7/2014)

The requirements of this item apply to units with the service notations **transshipping unit** or **transshipping floating terminal**, provided with the following characteristics:

- a navigation notation not exceeding the Coastal Area, and
- having a block coefficient not less than 0,9
- having a breadth/depth ratio greater than 3,0

The intact stability of units not complying with either one of the above characteristics is to comply with Pt B, Ch 3, Sec 2, unless otherwise decided by the Society, on a case by case basis, taking into account the unit's characteristics.

In this case, an appropriate entry is made in the classification files of the unit.

Items [2.1.2] and [2.1.3] do not apply to "Transshipping unit" or "Transshipping floating terminal" having no buffering capacity or having buffering capacity only within holds.

2.1.2 Trim and stability booklet (1/7/2014)

In addition to the information to be included in the trim and stability booklet specified in Pt B, Ch 3, App 2, [1.1], simplified stability guidance, such as a loading diagram, is to be submitted to the Society for approval, so that pontoons may be loaded in compliance with the stability criteria.

2.1.3 Stability calculations (1/7/2014)

Stability calculations may be carried out according to the following criteria:

- no account is to be taken of the buoyancy of deck cargo
- consideration is to be given to such factors as water absorption (e.g. timber), trapped water in cargo (e.g. pipes) and ice accretion
- in carrying out wind heel calculations:
 - the wind pressure is to be constant and for general operations considered to act on a solid mass extend-

ing over the length of the deck and to an assumed height above the deck

- the centre of gravity of the cargo is to be assumed at a point mid-height of the cargo
- the wind lever arm is to be taken from the centre of the deck cargo to a point at one half the draught
- calculations are to be carried out covering the full range of operating draughts
- the downflooding angle is to be taken as the angle at which an opening through which progressive flooding may take place is immersed. This would not be an opening closed by a watertight manhole cover or a vent fitted with an automatic closure.

2.1.4 Intact stability criteria (1/7/2014)

The following intact stability criteria are to be complied with, for the loading conditions specified in Pt B, Ch 3, App 2, [1.2.1] and Pt B, Ch 3, App 2, [1.2.2]:

- the area under the righting lever curve up to the angle of maximum righting lever is to be not less than 0,08 m.rad
- the static angle of heel due to a uniformly distributed wind load of 0,54 kPa (wind speed 30 m/s) may not exceed a heeling angle corresponding to half the freeboard for the relevant loading condition, where the lever of wind heeling moment is measured from the centroid of the windage area to half the draught
- the minimum range of stability is to be:
 - 20° for $L < 100$ m
 - 20° - 0,1° ($L - 100$) for $100 < L < 150$ m
 - 15° for $L > 150$ m.

2.2 Intact stability under operation

2.2.1 Application (1/7/2014)

The requirements of this item apply to units with the service notation "**transshipping unit**" or "**transshipping floating terminal**" and specify the criteria these units are to satisfy in addition to those in [2.1], during operation involving use of cargo lifting appliances.

2.2.2 Intact stability criteria during cargo lifting (1/7/2014)

The following intact stability criteria are to be complied with:

- $\theta_C \leq 15^\circ$
- $GZ_C \leq 0,6 GZ_{MAX}$
- $A_1 \geq 0,4 A_{TOT}$

where:

θ_C : Heeling angle of equilibrium, corresponding to the first intersection between heeling and righting arms (see Fig 1)

GZ_C, GZ_{MAX} : Defined in Fig 1

A_1 : Area, in m.rad, contained between the righting lever and the heeling arm curves, measured from the heeling angle C to the heeling angle equal to the lesser of:

- heeling angle θ_R of loss of stability, corresponding to the second intersection between heeling and righting arms (see Fig 1)
- heeling angle θ_F , corresponding to flooding of unprotected openings as defined in Pt F, Ch 13, Sec 11, [2.1.4] (see Fig 1)

A_{TOT} : Total area, in m.rad, below the righting lever curve.

In the above formula, the heeling arm, corresponding to the cargo lifting, is to be obtained, in m, from the following formula:

$$B_d = P_d - Z_z / \Delta$$

where:

- P : Cargo lifting mass, in t
- d : Transversal distance, in m, of cargo lifting to the longitudinal plane (see Fig 1)
- Z : Mass, in t, of ballast used to right the pontoon, if applicable (see Fig 1)
- z : Transversal distance, in m, of the centre of gravity of Z to the longitudinal plane (see Fig 1)
- Δ : Displacement, in t, at the loading condition considered.

The above check is to be carried out considering the most unfavourable situations of cargo lifting combined with the lesser initial metacentric height GM , corrected according to the requirements in Pt B, Ch 3, Sec 2, [4].

The residual freeboard of the unit during lifting operations in the most unfavourable stability condition is to be not less than 0,30 m. However, the heeling of the unit is not to produce higher loads in the lifting devices than those envisaged by the manufacturer, generally expected to be 5° in the boom plane and 2° transversally in the case of a crane.

The vertical position of the centre of gravity of cargo lifting is to be assumed in correspondence of the suspension point.

2.3 Intact stability for units carrying grain, cement and similar, IMSBC-A cargoes, nitrates, non-cohesive or other special cargo

2.3.1 Application (1/7/2014)

Units with the service notation "transhipping unit" or "transhipping floating terminal" having a buffer capacity in holds which are to be loaded with grain, cement and similar, IMSBC-A cargoes, nitrates, non-cohesive or other special cargo which may shift and affect the stability, are to comply with the specific additional criteria as indicated in Tab 1.

3 Design loads

3.1 Unit motions and accelerations

3.1.1 (1/7/2014)

In general, the values of unit motions and accelerations are to be derived from direct calculations, and justified on the basis of the unit's characteristics and intended areas of operation.

The values of unit motions and accelerations to be calculated are those which can be reached with a probability of 10-5 per cycle. In any case, the calculations, including the assumed sea scatter diagrams and spectra, are to be submitted to the Society for approval.

3.2 Additional requirements on local loads for units with the additional service feature heavycargo

3.2.1 (1/7/2014)

For units with a service notation completed by the additional service features **buffer** [x T, deck/holds] and **heavy-cargo** [HOLD*i*, X_i kN/m², ρ_i kN/m³ - DECK, Y_i kN/m²] (see Pt A, Ch 1, Sec 2, [4.11.1]), the values X_i and i , relevant to bulk cargoes carried in holds, and Y_i , relevant to uniform cargoes carried on deck, are to be taken according to [3.3.1].

3.3 Characteristics of bulk cargoes carried in holds

3.3.1 (1/7/2014)

ρ_i is, for each hold, the mass density of the cargo which fills the hold up to the upper deck level at centreline for the maximum mass which may be carried in that hold; ρ_i is to be defined by the designer and is to be greater than 1,0 t/m³.

X_i is the maximum allowable local pressure on the inner bottom of each hold and is to be specified by the designer. In any case, it is to be not less than the value obtained, for each hold, from the formula for p_s on the inner bottom in Pt B, Ch 5, Sec 6, [3.1.1], where the hold is to be considered as being completely filled and ρ_B is to be taken equal to i defined above.

4 Hull scantlings

4.1 General

4.1.1 (1/7/2014)

Foundations of cranes and conveyors are to be checked through direct calculations on the basis of:

- inertial loads in load cases "b" and "d" as defined in Pt B, Ch 5, Sec 4
- allowable stress as per Pt B, Ch 7, Sec 3.

Figure 1 : Cargo lifting (1/7/2014)

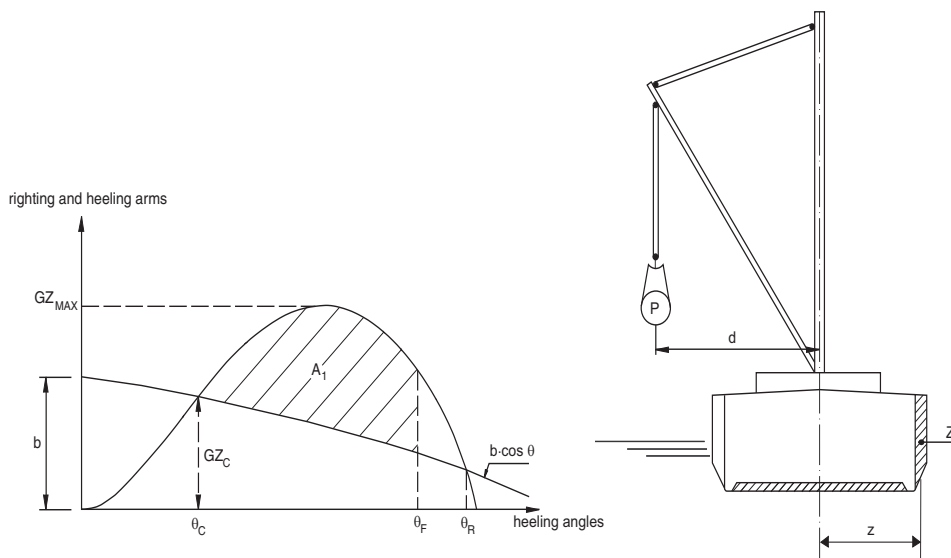

Table 1 : Documents to be submitted (1/7/2014)

No.	Cargo	Applicable criteria	Notes
1	Grain	Ch 4, Sec 3, [2]	
2	Cement and similar	Sec 2, [4]	
3	IMSBC-A cargoes	Pt F, Ch 13, Sec 18, [2]	The additional class notation "IMSBC-A" may be assigned
4	Nitrates	Pt F, Ch 13, Sec 18, [3]	The additional class notation "IMSBC-nitrate" may be assigned
5	Non-cohesive cargo	Pt F, Ch 13, Sec 18, [4]	The additional class notation "IMSBC-non cohesive" may be assigned
6	Other special cargo	The applicable criteria are to be established on a case by case basis, taking into account the properties of the proposed cargo	

CHEMICAL RECOVERY SHIPS

SECTION 1	GENERAL
SECTION 2	HULL AND STABILITY
SECTION 3	MACHINERY AND SYSTEMS
SECTION 4	ELECTRICAL INSTALLATIONS
SECTION 5	FIRE PROTECTION, DETECTION AND EXTINGUISHMENT

SECTION 1 GENERAL

1 General

1.1 Application

1.1.1 (15/2/2016)

Ships complying with the requirements of this Chapter are eligible for the assignment of the service notation **chemical recovery ship**, as defined in Pt A, Ch 1, Sec 2, [4.8.6].

Ships with this service notation are designed to:

- operate in hazardous atmosphere in case of an accident involving chemical products
- remove from the sea surface, retain, carry on board and unload chemical products.

1.1.2 (15/2/2016)

Ships dealt with in this Chapter are to comply with the requirements stipulated in Parts A, B, C and D, as applicable, and with the requirements of this Chapter, which are specific to chemical recovery ships for operations in hazardous atmosphere.

In addition, Ships dealt with in this Chapter are to comply with the requirements of the latest version of the International Code for the Construction and Equipment of Ships Carrying Dangerous Chemicals in Bulk (IBC Code), with the exception indicated in [1.1.3].

1.1.3 (15/2/2016)

For ships intended to collect and carry only the bulk liquids identified in Chapter 1, [1.2.2] of the IMO Resolution

A.673(16) and for which the aggregate quantity of cargo does not exceed the lesser of the following values:

- 800 m³
- 40% of ship DWT, in m³, calculated considering a cargo density of 1,0 t/m³

IMO Resolution A.673(16) applies in lieu of the IBC code.

1.2 Summary table

1.2.1 (15/2/2016)

Tab 1 indicates, for ready reference, the Sections of this Chapter containing specific requirements applicable to chemical recovery ships.

Table 1 (15/2/2016)

Main subject	Reference
Ship arrangement	(1)
Hull and stability	Sec 2
Machinery and systems	Sec 3
Electrical installations	Sec 4
Automation	(1)
Fire protection, detection and extinction	Sec 5
(1) No specific requirements for chemical recovery ships are given in this Chapter.	

SECTION 2

HULL AND STABILITY

1 General

1.1

1.1.1 (15/2/2016)

The requirements given in the IBC code or IMO Resolution A.673(16), as applicable according to Sec 1, [1.1], are to be considered for cargo tanks location, cargo segregation and any other relevant aspects.

2 Documentation to be submitted

2.1

2.1.1 (15/2/2016)

The following documentation is to be submitted:

- a) details of air locks
- b) details of accesses and openings which are to be closed gas-tight during operations in hazardous atmosphere
- c) windows plan drawings with information about materials used
- d) general arrangement, capacities and drawings of the cargo tanks/holds.

3 Operations in hazardous atmosphere

3.1 Citadel

3.1.1 (15/2/2016)

A citadel area protected against penetration by hazardous atmosphere is to comprise any enclosed space in the ship in continuous use during service. In this area, an overpressure is to be maintained in order to avoid entrance of hazardous substances from outside.

Accesses and openings into the citadel area are to be capable to be closed gas-tight.

3.1.2 Air locks (15/2/2016)

Air locks with two self-closing doors are to be fitted for the entrance into the citadel area in order to maintain the overpressure inside. Forced ventilation is to be fitted in order to avoid the entrance of hazardous substances and an alarm is to be provided to indicate if both doors are open.

3.2 Windows

3.2.1 (15/2/2016)

Design pressure, arrangement and composition of the windows are to be considered by the Society on a case by case basis.

SECTION 3

MACHINERY AND SYSTEMS

1 Machinery and systems installations

1.1

1.1.1 (15/2/2016)

The requirements given in the IBC code or IMO Resolution A.673(16), as applicable according to Sec 1, [1.1], are to be considered for recovered chemical products pumping and piping systems, cargo area equipment, ventilation and any other issue relevant to machinery and systems.

2 Documentation to be submitted

2.1

2.1.1 (15/2/2016)

The following documentation is to be submitted:

- general plan of the system for chemical products recovery and specification of all relevant apparatuses
- schematic arrangement of recovered chemical products pumping and piping systems
- tank venting arrangement
- plans, drawings and design calculation of the citadel ventilation system
- proof of suitability of the air filters material
- plan of closing appliance for operations in hazardous atmosphere
- details of the design of the gas detection equipment with proof of suitability
- operations and equipment manual for operations in hazardous atmosphere.

3 Operations in hazardous atmosphere

3.1 Citadel ventilation system

3.1.1 (15/2/2016)

For the ventilation of the citadel area during operation in hazardous atmosphere, specific systems such as filtration plant for cleaning the outside air or circulating-air regeneration plant is to be fitted.

The design parameters for the mentioned plants, the values of which are to be considered by the Society on a case by case basis, are:

- maximum CO₂ concentration of the air inside the citadel
- minimum value of the overpressure during service in hazardous atmosphere.

The overpressure and the CO₂ concentration are to be monitored and, in case of anomalous values, an alarm is to be activated.

3.1.2 Regeneration plant (15/2/2016)

The regeneration plant is to maintain the CO₂ concentrations and the overpressure in the citadel by means of a compressed air reservoir. Its pressure and the oxygen content in the air fed into the citadel are to be monitored and an alarm is to be activated in case of anomalous values.

3.1.3 Filtration plant (15/2/2016)

The filtration plant is to clean the outside air to be fed into the citadel area by means of filters. A monitoring system is to be fitted with an alarm to be activated in case of any penetration of hazardous substances. A redundancy of the system is to be provided. The air flow rate of the plant and the location of the intake of the plant are to be considered by the Society on a case by case basis.

3.2 Gas detection and alarm

3.2.1 (15/2/2016)

A gas detection and an alarm system are to be provided on board for the detection of flammable and toxic gases and vapours in the atmosphere. Measuring points are to be considered by the Society on a case by case basis.

3.3 Machinery intake air system

3.3.1 (15/2/2016)

The combustion air for engines, gas turbines, boilers and incinerators is to be monitored for the presence of flammable gases and vapours near the intakes. The location of the intake openings are to be considered by the Society on a case by case basis.

The air ducts are to be explosion-resistant and provided with flame arrestors.

The engines are to be either totally encased or totally gastight.

3.4 Machinery exhaust gas system

3.4.1 (15/2/2016)

Exhaust lines from engines, gas turbines, boilers and incinerators are to be led to a gas-safe position as high as practicable above the deck and are to be fitted with a spark and flame arrester.

The maximum exhaust gas temperature at the outlets is to be considered by the Society on a case by case basis and is to be monitored with an alarm system which is to be activated if the maximum permissible temperature is exceeded.

An air cooler is to be fitted in the machinery space to remove the heat.

3.5 Operations and Equipment Manual

3.5.1 (15/2/2016)

An Operations and Equipment Manual, approved by the Society, is to be carried on board.

It is to contain:

- safety measures to be adopted before starting the operations in hazardous atmosphere
- safety measures to be adopted during the operations in hazardous atmosphere
- documentation and descriptions of the technical installations present on board
- appropriate measures in case of alarms
- plans of spaces with overpressure, closing appliances, arrangement of equipment and appliances for operations in hazardous atmosphere.

SECTION 4

ELECTRICAL INSTALLATIONS

1 General

1.1 Application

1.1.1 (15/2/2016)

The electrical plants on board are to comply with the requirements in the IBC code or IMO Resolution A.673(16), as applicable according to Sec 1, [1.1].

2 Documentation to be submitted

2.1

2.1.1 (15/2/2016)

The following documentation is to be submitted:

- a) plan of dangerous areas subjected to explosion hazard during operations in hazardous atmosphere and of the areas with overpressure
- b) document giving details of types of cables and safety characteristics of the equipment installed in hazardous areas
- c) electric power balance for service in hazardous atmosphere.

SECTION 5

FIRE PROTECTION, DETECTION AND EXTINCTION

1 General

1.1 Application

1.1.1 (15/2/2016)

The requirements given in the IBC code or IMO Resolution A.673(16), as applicable according to Sec 1, [1.1], are to be considered for fire protection, detection and extinction.

2 Operations in hazardous atmosphere

2.1 General

2.1.1 (15/2/2016)

Machinery spaces which are not permanently manned or which are not accessible during service in hazardous atmosphere are to be provided with fire detection and alarm system.

WELL STIMULATION SHIPS

- SECTION 1 GENERAL**
- SECTION 2 HULL AND STABILITY**
- SECTION 3 MACHINERY AND SYSTEMS**
- SECTION 4 ELECTRICAL INSTALLATIONS**
- SECTION 5 FIRE PROTECTION, DETECTION AND EXTINGUISHION**
- SECTION 6 PERSONNEL PROTECTION**

SECTION 1

GENERAL

1 General

1.1 Application

1.1.1 (1/4/2016)

OSVs complying with the requirements of this Chapter are eligible for the assignment of the service notation **well stimulation**, as defined in Pt A, Ch 1, Sec 2, [4.8.10].

If the ship carries only product with flashpoint exceeding 60°C, this restriction will be reported on the ship operation manual and the additional service feature flash point > 60°C is assigned.

In the case of ships provided with tanks dedicated to the containment of product with flashpoint 60°C and others dedicated to the containment of product having flashpoint > 60°C, in the ship operation manual and in the ship documents it is to be clearly indicated for each tank which is the allowed flashpoint of the product contained therein.

1.1.2 (1/4/2016)

Ships dealt with in this Chapter are to comply with the requirements stipulated in Parts A, B, C and D, as applicable, and with the requirements of this Chapter, which are specific for the assignment of the service notation **well stimulation**.

1.2 Summary table

1.2.1 (1/4/2016)

Tab 1 indicates, for ready reference, the Sections of this Chapter containing specific requirements applicable to well stimulation ships.

Table 1 (1/4/2016)

Main subject	Reference
Ship arrangement	(1)
Hull and stability	Sec 2
Machinery and systems	Sec 3
Electrical installations	Sec 4
Automation	(1)
Fire protection, detection and extinction	Sec 5
Personnel protection	Sec 6
(1) No specific requirements for the assignment of the service well stimulation are given in this Chapter	

SECTION 2

HULL AND STABILITY

1 General

1.1 Tanks for storage of stimulating liquids

1.1.1 (1/4/2016)

Where it is intended to carry acids in bulk on well stimulation vessels, the arrangement is to comply with the requirements of Chapter 15 of the IBC Code.

Where it is intended to carry liquid nitrogen in bulk on well stimulation vessels, the arrangement is to comply with the applicable requirements of Chapter 17 of the IGC Code.

1.1.2 (1/4/2016)

Tanks for storage of stimulating liquid such as acids and nitrogen, are to be design and constructed in accordance with pertinent requirements for pressure vessel, IBC Code, LHNS Guidelines (Res. A.673(16) as amended) and ICG Code, as applicable.

1.2 Tanks material

1.2.1 (1/4/2016)

Material used for the construction of tanks intended for stimulating liquids is to be tested and certified according to Part D.

1.3 Documents to be submitted

1.3.1 (1/4/2016)

Tab 1 lists the plans or documents that are to be submitted to the Society, as applicable.

Table 1 : Documents to be submitted (1/4/2016)

No.	A/I (1)	Document
1	A	Operation manual for well stimulation procedures
2	I	Arrangement of tanks
3	I	Documentation for liquid nitrogen tanks as required by Chapter 9 for liquefied gas carriers
4	I	Drawing of support and staying of independent tanks
5	I	Drawing of acid tanks including information of non-destructive testing of welds, strength and tightness
6	I	Testing of tanks and specification of lining
(1)	A = to be submitted for approval in four copies I = to be submitted for information in duplicate	

1.4 Operational Manual

1.4.1 (1/4/2016)

An approved Operational Manual is to be readily available on board. The manual has to provide instructions and information on the safety aspects related to well stimulating processing.

1.4.2 (1/4/2016)

The approved Operational Manual has to cover particulars on:

- protective equipment
- storage and handling of fluids and dry additives
- transfer operations
- emergency shutdown and disconnection.

2 General arrangement design

2.1 Tank location and segregation of spaces

2.1.1 Tanks location (1/4/2016)

Tanks are to be located at a minimum distance from the side shell and bottom, i.e 760 mm measured inboard from the side of the vessel perpendicular to the centerline at the level of the summer load waterline.

2.1.2 Segregation (1/4/2016)

Tanks and pumping arrangements for the well stimulation plants are to be segregated from machinery spaces, propeller shaft tunnels (if provided), dry cargo spaces, accommodation and service spaces, as well as from drinking water tanks and provision stores by means of cofferdam, void space, cargo pump room, empty tank, oil fuel tank or other similar spaces.

2.2 Protection from liquid spill

2.2.1 (1/4/2016)

The following protections from acid spills are to be provided:

- Floors or decks protection: floors or decks under storage tanks, pumps and piping for acid are to have a lining or coating of corrosion-resistant materials extending up to a minimum height of 500 mm on the bounding bulkheads or coamings; hatches or similar openings in such floors or decks are to be raised to a minimum height of 500 mm and the coamings are to be protected by a lining or an acid resistant coating
- Spray shields and drip trays: spray shields are to be provided to cover flanges and other detachable pipe connections (portable shield covers are to be provided for connecting the flanges of the loading manifold) and drip

trays of corrosion-resistant material are to be provided under loading manifolds.

- c) Drainage arrangement: spaces for storage tanks, pumps and piping for acid are to be provided with drainage arrangement of corrosion-resistant materials separated from draining system of the other areas.

2.2.2 (1/4/2016)

Adequate protection from nitrogen spill is to be provided to prevent cold cracking of structure: for this purpose drip trays resistant to cryogenic temperatures are to be provided at manifolds transferring liquefied gases and at other flanged connections in the system.

2.2.3 (1/4/2016)

A permanent spill coaming of 150 mm in height is to be provided on deck to keep deck spill away from accommodation and service areas

2.3 Hazardous area

2.3.1 (1/4/2016)

Hazardous areas are to be defined in relation with the liquids and additives used for stimulation operation and the layout of relevant systems. Due consideration is to be given to the location of air intakes and openings into accommodation, service and machinery spaces and control station in relation to cargo piping and cargo vent system.

2.4 Accesses, Air intakes, windows and other openings to accommodation spaces

2.4.1 (1/4/2016)

Accommodation, service spaces and control stations are not to be located within the cargo area.

2.4.2 (1/4/2016)

Unless they are spaced at least 7 m away from the hazardous area, entrances, air intakes and openings to accommodation, service and machinery spaces and control stations are not to face the cargo area.

2.4.3 (1/4/2016)

When arranged within the 7 m zone specified in [2.4.2], windows and sidescuttles facing the cargo area are to be of a fixed type ensuring an efficient gas-tight closure; such sidescuttles in the first tier on the main deck are to be fitted with inside covers of steel or equivalent material.

2.4.4 (1/4/2016)

Doors to spaces not having access to accommodation, service and machinery space and control stations, such as cargo control station and store-rooms, may be accepted within the 7 m specified in [2.4.2] provided that the boundaries of the spaces are insulated to A-60 standard.

2.5 Access to spaces in the cargo area

2.5.1 (1/4/2016)

Access to spaces within the cargo area is to meet the requirements of Paragraph 3.4 of the IBC Code.

3 Stability

3.1 Intact stability

3.1.1 (1/4/2016)

The stability of the ship for the loading conditions reported in the trim and stability booklet is to be in compliance with the requirements in Pt B, Ch 3, Sec 2.

3.2 Damage stability

3.2.1 (1/4/2016)

Damage stability is to be suitable to cope with damage to be assumed to occur anywhere in the ship's length at any transverse watertight bulkhead whenever the ship carries hazardous and noxious liquid substances more than the lesser between 800 m³ or a volume in cubic m equal to 40% of ship's deadweight calculated at a cargo density of 1.0.

4 Hull scantlings

4.1 Local loads

4.1.1 (1/4/2016)

Stress analysis is to be carried out for supporting structure in way of flexible hose storage well(s) and possible other pieces of equipment of significant weight.

4.2 Movable tanks

4.2.1 (1/4/2016)

The net scantlings of movable tanks are considered by the Society on a case-by-case basis.

5 Seakeeping

5.1 General

5.1.1 (1/4/2016)

The ship is to be capable, within given environmental limit conditions, of maintaining the position during stimulation operation either by means of anchoring arrangement or dynamic positioning system.

5.2 Dynamic positioning

5.2.1 (1/4/2016)

Dynamic positioning system, when used to maintain the vessel's position during well stimulation operations, is to comply with the requirements for the additional class notation **DYNAPOS** (see Pt F, Ch 12, Sec 3).

5.3 Station keeping with anchors and cables

5.3.1 (1/4/2016)

Position mooring with anchors, cable and mooring winches are to fulfill the requirements for position mooring system of Part B, Chapter 9 of Rules for the Classification of Floating Offshore Units at Fixed Locations and Mobile Offshore Drilling Units. Safety precautions are to be considered to prevent damaging seabed equipment and installation by deployment, recovery and station keeping.

SECTION 3 MACHINERY AND SYSTEMS

1 General

1.1 Application

1.1.1 (1/4/2016)

This Section provides, for OSVs having the service **well stimulation**, specific requirements for:

- machinery systems
- tanks
- pumping and piping systems.

The requirements of this Section apply, in addition to those contained in Part C, Chapter 1, and:

- when acids are intended to be carried in bulk on well stimulation vessels, the arrangement is to comply with the requirements of Chapter 15 of the IBC Code;
- when liquid nitrogen in bulk is intended to be carried on well stimulation vessels, the arrangement is to com-

ply with the applicable requirements of Chapter 17 of the IGC Code.

1.2 Documents to be submitted

1.2.1 (1/4/2016)

The documents listed in Tab 1 are to be submitted.

1.3 Calculations

1.3.1 (1/4/2016)

The following calculations are to be submitted and documented:

- propulsion power required for the vessel to maintain position during well stimulation operations
- stress analysis of liquid nitrogen piping
- stress analysis of liquid nitrogen heat exchangers
- stress analysis of high pressure piping.

Table 1 : Documents to be submitted (1/4/2016)

No.	A/I (1)	Document
1	A	Cargo tank level measurement system
2	A	Cargo tank overflow protection system
3	A	Emergency shut-down system
4	A	Hydrogen indication equipment
5	A	Hydrogen chloride indication equipment
6	A	Oxygen indication equipment
7	I	Pumping arrangements
8	I	Arrangement of ventilation pipes from acid tanks
9	I	Mechanical ventilation arrangement of closed and semi-enclosed spaces containing acid tanks, pipes
10	I	Pumps and mixing units
11	I	Diagrams of piping for acid, nitrogen and liquid additives including details such as flange connections and securing of pipes
12	I	Drawings of pumps and mixers
13	I	Specification and information on high pressure flexible hoses with end connections
14	I	Drawings and particulars for nitrogen vaporiser
15	I	Drawings and particulars of nitrogen heat exchangers
<p>(1) A = to be submitted for approval in four copies I = to be submitted for information in duplicate</p> <p>(2) Diagrams are also to include, where applicable, the local and remote control, the monitoring and automation systems.</p>		

2 Machinery installations and piping systems not intended for well stimulation

2.1 Bilge system

2.1.1 (1/4/2016)

Bilge arrangements for pump rooms, void spaces, any slop tank, double bottom tanks and similar spaces related to the well stimulation process are to be situated entirely within the well stimulation processing area. The same applies to spaces directly adjacent to such spaces.

2.2 Exhaust gas systems

2.2.1 (1/4/2016)

Exhaust lines from engines, gas turbines, boilers and incinerators are to be led to a gas-safe position as high as practicable above the deck and are to be fitted with a spark arrester.

2.2.2 (1/4/2016)

Where the distance between the exhaust lines of engines and the gas-dangerous area is less than 3 m, the ducts are to be fitted in a position:

- near the waterline if cooled by water injection, or
- below the waterline in other cases.

2.3 Additional requirements for machinery installations in hazardous area

2.3.1 (1/4/2016)

Attention is drawn to the risk of ignition in hazardous area from sparking due to:

- formation of static electricity, or
- friction between moving parts.

2.3.2 (1/4/2016)

Surface temperature of equipment in hazardous area is not to exceed the allowable temperature depending on the type of hazard.

2.3.3 (1/4/2016)

The installation of certified safe type internal combustion engines may be permitted in zone 2 open gas-dangerous areas, subject to special consideration by the Society.

3 Pumping system, piping system and pump rooms intended for well stimulation

3.1 Design of piping systems

3.1.1 General (1/4/2016)

Piping is to be designed and constructed in accordance with pertinent requirement for pressure vessel, Chapter 5 of the IBC Code, Chapter 3 of the LHNS Guidelines (Res. A.673(16) as amended) and Chapter 5 of the ICG Code, as applicable.

Materials to be used in piping systems is to be tested and certified according to Pt C, Ch 1, Sec 9.

3.2 Arrangement

3.2.1 (1/4/2016)

Piping systems for the well stimulation plant is to be separated from other piping systems; they are not to pass through any accommodation, service or machinery space other than cargo pump rooms or pump rooms.

3.2.2 (1/4/2016)

Pumps, ballast lines, vent lines and other similar equipment serving permanent ballast tanks are to be independent of similar equipment serving cargo tanks.

3.2.3 (1/4/2016)

Piping for acids shall be in corrosion resistant material or coated by an approved lining.

3.2.4 (1/4/2016)

Piping for the handling of flammable or hazardous and noxious liquid substances for well stimulation is to comply with the pertinent provisions given in Chapter 7 or Chapter 8 or Chapter 9, as applicable for the intended liquid.

3.2.5 (1/4/2016)

Piping is to be permanently installed; however, the use of portable pumps may be permitted subject to special consideration by the Society.

3.3 Pump rooms

3.3.1 (1/4/2016)

Pump rooms containing the pumps for handling the liquids intended for well stimulation are to comply with the pertinent provisions given in Chapter 7 or Chapter 8 or Chapter 9, as applicable for the intended liquid.

3.4 Venting systems

3.4.1 (1/4/2016)

Tank venting systems are to be designed and fitted taking in account both safety and health hazard; due consideration is to be given to the location of safety valves and pressure/vacuum valves outlets with regard to source of ignition, source of heat, accommodation and service spaces.

Relevant provision of Chapter 8 of the IBC Code, Chapter 3 of the LHNS Guidelines (Res. A.673(16) as amended) and Chapter 8 of IGC Code are to be dealt with, as applicable.

3.5 Mechanical ventilation of spaces in the cargo area

3.5.1 (1/4/2016)

Mechanical ventilation for:

- spaces housing acid tanks has to ensure a capacity of 30 air changes per hour
- spaces containing installations for nitrogen have to ensure a capacity of 20 air changes per hour
- spaces for storage and handling of dry and liquid additives is to be case by case considered based on flammability, toxicity and reactivity criteria of the additives concerned
- mechanical ventilation of spaces in the cargo area classified as an hazardous area is to comply with the requirements in IBC Code Chapter 12.

3.6 Control and Monitoring

3.6.1 Vapour detection (1/4/2016)

Enclosed and semi-enclosed spaces containing installations for acids are to be provided with fixed vapour detection and alarm systems capable of giving an audible and visual alarm. The vapour detection system is to be capable of detecting hydrogen and hydrogen chloride gases.

3.6.2 Oxygen deficiency monitoring (1/4/2016)

Enclosed spaces containing tanks and piping for liquid nitrogen are to be equipped with a sensor continuously monitoring the oxygen content of the space; an alarm is to be provided in case of low oxygen concentration. For semi-enclosed spaces portable equipment may be accepted.

3.6.3 Tank level gauging and alarm system (1/4/2016)

Nitrogen tanks for liquefied nitrogen are to have gauging and level detection arrangements in accordance with Chapter 13 of IGC Code.

Tanks for hydrochloric acid are to have a closed gauging system. A high level alarm is to be provided to be activated by a level sensing device independent of the gauging system.

3.6.4 Emergency control (1/4/2016)

Emergency control is to be provided for:

- a) Stopping the cargo pumps and similar equipment and shutoff valves in nitrogen outlet lines from each tank;

these emergency controls are to be capable of being activated from a dedicated cargo control location which is manned at the time of the cargo transfer and from at least one other location outside the cargo area and at a safe distance from

- b) Emergency depressurizing and disconnection of the transfer hose; these control for activating emergency depressurization and disconnection are to be located in a dedicated cargo control location which is manned at the time of the cargo transfer and in another location outside the cargo area and at a safe distance from it

Where auxiliary electrical energy is required for functionality of emergency controls, a reliable power supply is to be provided as indicated in Sec 4, [2.1.1]; where hydraulic and/or pneumatic power is used for actuation of emergency control and shutdown, pumps or compressors are to be duplicated. Where hydraulic pumps and/or compressors used for emergency control are driven by an electric motor, one motor is to be supplied from the main source of electrical power and the other from the emergency sources of electrical power.

3.6.5 (1/4/2016)

Where applicable, well blowout preventer closing system and disconnection from the blowout preventer is to be provided from a position located at a safe and readily accessible location.

SECTION 4

ELECTRICAL INSTALLATIONS

1 General

1.1 Application

1.1.1 (1/4/2016)

The requirements in this Section apply, in addition to those contained in Part C, Chapter 2.

Pertinent provisions of IBC Code and IGC Code are to be dealt with, as far as applicable.

1.2 Documents to be submitted

1.2.1 (1/4/2016)

In addition to the documentation requested in Pt C, Ch 2, Sec 1, [2.1.1], the following is to be submitted:

- a) single line diagrams of the power supply to well stimulation equipment
- b) plan of hazardous area,
- c) drawing showing location of all electrical equipment installed in hazardous areas,
- d) list of electrical equipment installed in hazardous area, including type, manufacturer, safety characteristics and type of protection, together with the relevant safety certificates,
- e) single line diagram for intrinsically safe circuits.

2 Design requirements

2.1 Power supply for emergency controls

2.1.1 (1/4/2016)

Electrical power supply for emergency controls is to be taken from the ship's main supply and from an uninterruptible power supply (UPS) capable of continuously operating the systems for at least 30 minutes upon loss of the normal power supply. The UPS is to be powered by means of two

circuits, one from the main source of electrical power and the other from the emergency source of electrical power.

2.2 Earth detection

2.2.1 (1/4/2016)

For both insulated and earthed distribution systems a device, or devices, are to be installed to continuously monitor the insulation to earth and to give an audible and visual alarm at a manned position in the event of an abnormally low level of insulation resistance and/or high level of leakage current.

3 Hazardous area

3.1 Hazardous area classification

3.1.1 (1/4/2016)

Hazardous area classification is to be defined in relation with the liquids and additives used for stimulation operation and the layout of relevant systems. Reference is made also to pertinent requirement of Pt E, Ch 4, Sec 5 of Rules for the Classification of Floating Offshore Units at Fixed Locations and Mobile Offshore Drilling Units.

3.2 Electrical equipment permitted in hazardous area

3.2.1 (1/4/2016)

For the type of electrical equipment permitted in hazardous areas reference is to be made to Pt C, Ch 2, Sec 3, [10].

3.2.2 (1/4/2016)

The following control and monitoring systems shall be certified for the intended use.

- Cargo tank level measurement system
- Cargo tank overflow protection system
- Emergency shutdown system.

SECTION 5

FIRE PROTECTION, DETECTION AND EXTINCTION

1 General

1.1 Application

1.1.1 (1/4/2016)

The following provisions regarding fire protection, detection and extinction are not mandatory for the purpose of classification, except where the Society carries out surveys relevant to fire protection statutory requirements on behalf of the flag Administration. In such cases, fire protection statutory requirements are considered a matter of class and therefore compliance with these requirements is also verified by the Society for classification purposes at class surveys.

1.2 Fire Protection, Fire Fighting system and appliances

1.2.1 (1/4/2016)

In general pertinent requirement foreseen by:

- a) Rules for Fire Protection, Detection and Extinction for the Issue and Maintenance of the SOLAS Certificates
- b) Chapter 11 of IBC Code
- c) Chapter 3 of the LHNS Guidelines (Res. A.673(16) as amended)
- d) Chapter 11 of IGC Code

are enforced, as far as applicable, in consideration of the well stimulation system and relevant outfitting.

SECTION 6

PERSONNEL PROTECTION

1 General

1.1 Personnel protection

1.1.1 (1/4/2016)

The following personnel protective equipment is to be provided as appropriate decontamination showers and eyewashes: a suitably marked decontamination shower and eyewashes are to be available on deck in a convenient location. The shower and eyewash are to be operable in all ambient conditions.

Protective and safety equipment is to be kept on board in suitable locations as required by Chapter 14 of the IBC Code or Chapter 14 of the IGC Code.

MARINE MOBILE DESALINATION UNIT

SECTION 1	GENERAL
SECTION 2	HULL AND STABILITY
SECTION 3	MACHINERY AND CARGO SYSTEMS

SECTION 1

GENERAL

1 General

1.1 Application

1.1.1 (9/12/2019)

Ships complying with the requirements of this Chapter are eligible for the assignment of the service notation **marine mobile desalination unit**, as defined in Pt A, Ch 1, Sec 2, [4.5.13].

Ships with the service notation are:

- provided with a desalination plant capable of producing drinking water by removing salt and minerals from sea water adopting different recognized methods (e.g. electro-dialysis, reverse osmosis, distillation, etc.); and
- intended to carry the produced drinking water in their own cargo tanks.

1.1.2 (9/12/2019)

Ships dealt with in this Chapter are to comply with the requirements stipulated in Parts A, B, C and D of the Rules, as applicable, and with the requirements of Chapter 10, which are specific to tankers.

1.1.3 (9/12/2019)

Service notation **marine mobile desalination unit**, is assigned to tankers carrying water, only.

1.2 Summary table

1.2.1 (9/12/2019)

Tab 1 indicates, for ready reference, the Sections of this Chapter containing specific requirements applicable to desalination tanker ships.

Table 1 (9/12/2019)

Main subject	Reference
Ship arrangement	(1)
Hull and stability	Sec 2
Machinery and systems	Sec 3
Electrical installations	(1)
Automation	(1)
Fire protection, detection and extinction	(1)
(1) No specific requirements for marine mobile desalination unit are given in this Chapter.	

1.3 Definitions

1.3.1 Cargo area (9/12/2019)

The cargo area is that part of the ship that contains cargo tanks as well as slop tanks, cargo pump rooms including pump rooms, cofferdams, ballast or void spaces adjacent to cargo tanks or slop tanks as well as deck areas throughout the entire length and breadth of the part of the ship above these spaces.

When independent tanks are installed in hold spaces, the cofferdams, ballast or void spaces at the after end of the aftermost hold space or at the forward end of the forwardmost hold space are excluded from the cargo area.

1.3.2 Cargo pump room (9/12/2019)

Cargo pump room is a space containing pumps and their accessories for the handling of products covered by the service notation granted to the ship.

1.3.3 Cargo service spaces (9/12/2019)

Cargo service spaces are spaces within the cargo area used for workshops, lockers and storerooms of more than 2 m² in area, intended for cargo management equipment.

1.3.4 Slop tank (9/12/2019)

Slop tank means a tank specifically designated for the collection of tank draining, tank washings and other treatment mixtures.

1.3.5 Redundancy (9/12/2019)

Ability of a component or system to maintain or restore its function, when a single failure has occurred. Redundancy can be achieved, for instance, by installation of multiple components, systems or alternative means of performing a function. Different arrangement, may be permitted subject to special consideration by the Society. Loss of complete treatment capability, involves the loss of **marine mobile desalination unit** notation.

SECTION 2 HULL AND STABILITY

1 General arrangement design

1.1 Cargo Tanks

1.1.1 (9/12/2019)

Marine mobile desalination unit may be built with independent or integral cargo tanks. For carriage of drinking water it is assumed that cargo tanks are not used for any other purposes, except under emergency conditions. Specification of tank coating with certificate of acceptance for toxicity and tainting testing by recognized laboratory and health authority is to be submitted.

1.1.2 (9/12/2019)

Cargo tanks are not to be used for ballasting the ship; when it is not possible to do otherwise, a procedure is to be provided. Such procedure shall include that the cargo tanks and piping are washed using drinkable water.

1.1.3 (9/12/2019)

In case the ship is provided with integral cargo tanks, cofferdams are to be fitted between tanks and compartments intended for liquids likely to alter drinking water carried. Cargo tanks are to be separated from any compartment containing heat sources by cofferdams or duly heat-insulated bulkheads.

1.1.4 (9/12/2019)

In general, each cargo tank is to be fitted with:

- a graduated metal gauge rod or any other equivalent sounding device,
- an inspection door of adequate size fitted with a water-tight metal cover secured by wing bolts or any other device offering equivalent safety,
- sealing gaskets for all hatches providing access to cargo tanks, certified as having harmless properties to edible liquid.

1.2 Segregation of spaces intended for the water treatment system

1.2.1 (9/12/2019)

Spaces intended for the water treatment system are to be considered as machinery spaces and are to be separated from service and accommodation spaces.

1.3 Storage and handling of chemical products used for treatment

1.3.1 (9/12/2019)

Due consideration is to be given to the safety implications due to the storage and use of chemical products for the

treatment system. Such implications are to be documented in the operation and maintenance manual taking into account the properties of each product and relevant safety warning reported in its own safety datasheet. In addition suitable warning notices placed in the storage and handling areas are to be provided accordingly.

1.3.2 (9/12/2019)

Chemical products, in general, are to be stored in an ad hoc space. The storage area of chemical products can be allowed also within a machinery space others than machinery spaces of category A. In any case, the following requirements are to be complied with:

- the area identified for the storage is to be well ventilated;
- monitoring is to be frequently carried out by the crew to ascertain the absence of leaks, ruptures, etc.;
- in case of toxic products, storage is to be made at a safe distance from ventilation or access openings to other enclosed spaces;
- corrosive products are to be stored outside areas where equipment for navigation and safety are located;
- the storage area is to be at a safe distance from heat sources or in a position not easily exposed to open flames in case of fire;
- compliance with Sec 3, [4.2] is required;
- the products are properly stowed and secured so as to minimize the hazards to the marine environment without impairing the safety of the ship and persons on board;
- the tanks are to be made of materials resistant to the product intended to be stowed;
- the storage is always to be carried out in compliance with segregation criteria (see Fig 1).

2 Stability

2.1 Intact stability

2.1.1 General (9/12/2019)

The stability of the ship for the loading conditions in Pt B, Ch 3, App 2, [1.2.3] is to be in compliance with the requirements in Pt B, Ch 3, Sec 2.

In particular, a sufficient number of loading conditions representing the initial, intermediate and final stages of the filling or discharge operation using the free surface correction at the filling level in each tank at the considered stage shall be included in the stability booklet.

Figure 1 : Segregation Chart (9/12/2019)

DANGEROUS CLASS ID	2.1	2.2	2.3	3	4.1	4.2	4.3	5.1	5.2	6	7	8	9	Foods	Substances having risk of fire
	Y	Y	Y	Y	N	N	N	N	N	Y	N	Y	Y	Y	Y
	Y	Y	Y	Y	Y	N	Y	Y	N	Y	Y	Y	Y	Y	Y
	Y	Y	Y	N	Y	N	Y	N	N	Y	Y	Y	Y	N	Y
	Y	Y	N	Y	Y	N	Y	N	N	Y	N	Y	Y	Y	Y
	N	Y	Y	Y	Y	N	Y	N	N	Y	N	Y	Y	Y	Y
	N	N	N	N	N	Y	Y	N	N	Y	N	Y	Y	Y	Y
	N	Y	Y	Y	Y	Y	Y	N	N	Y	N	N	Y	Y	Y
	N	Y	N	N	N	N	N	Y	N	Y	N	N	Y	Y	N
	N	N	N	N	N	N	N	N	Y	Y	N	N	Y	Y	N
	Y	Y	Y	Y	Y	Y	Y	Y	Y	Y	Y	Y	Y	N _{exp}	Y
	N	Y	Y	N	N	N	N	N	N	Y	Y	N	Y	N _{exp}	Y
	Y	Y	Y	Y	Y	Y	N	N	N	Y	N	Y	Y	N _{exp}	Y
	Y	Y	Y	Y	Y	Y	Y	Y	Y	Y	Y	Y	Y	Y	Y

SECTION 3

MACHINERY AND CARGO SYSTEMS

1 General

1.1 Application

1.1.1 (9/12/2019)

This Section provides, for ships having the service notation **marine mobile desalination unit**, specific requirements for the desalination system.

1.2 Documents to be submitted

1.2.1 (9/12/2019)

The documents listed in Tab 1 are to be submitted.

2 Piping systems

2.1 General

2.1.1 Materials (9/12/2019)

- a) Materials used for piping systems are to comply with the provisions of Pt C, Ch 1, Sec 10, [2.1].
- b) Attention is drawn to any national standards or regulations which might restrict the use of materials in contact with edible substances.
- c) Valves and associated gasket of desalination piping system are to be suitable for use in contact with edible substances.

3 Desalination system: pumping and piping systems

3.1 Design of pumping and piping systems

3.1.1 General (9/12/2019)

- a) The relevant provisions of Pt C, Ch 1, Sec 10 are to be complied with.
- b) The pumping and piping systems intended for desalination system are to be independent from other pumping and piping systems of the ship from the operational and functional point of view. Exception can be done for the seachests with associated inlet pipes that can be common with other systems requiring sea water from seachest.
- c) Piping is to be permanently installed. However, the use of portable pumps may be permitted, subject to special consideration by the Society.
- d) Arrangements are to be made to avoid any inadvertent contamination of the cargo. In particular, the filling and discharge connections serving the cargo tanks are to be

located remote from those serving the machinery piping system.

- e) Inlet seachest is to be located as far away as possible from any eventual desalination system outlets.

3.1.2 Passage of pipes through tanks (9/12/2019)

- a) Apart pipes used for conveying treated water, cargo tanks are not to be passed through by pipes conveying other liquids. See also [3.2.1].
- b) When, for technical reasons, it is necessary that pipes pass through cargo tanks, they must be made in stainless steel and fulfil the following provisions:
 - they are to have welded or heavy flanged joints the number of which is kept to a minimum
 - they are to be of extra-reinforced wall thickness
 - they are to be adequately supported and protected against mechanical damage.

3.2 Pumping System

3.2.1 Cargo pumps (9/12/2019)

At least two cargo pumps are to be provided for transferring the cargo.

Submerged cargo pumps may be used provided that they are fitted with a double barrier between the driving oil and cargo; oil or cargo leakages into the double barrier are to be detectable. As alternative to double barrier, hydraulic oil harmless to the edible liquid can be used.

Hydraulically operated valves are not to be located inside cargo tanks unless the hydraulic fluid used is harmless to the edible liquid quality in case of a leakage of hydraulic fluid.

Pumps used for the treatment of water are to be made in stainless steel, or in other material suitable for edible water.

3.2.2 Desalination system pumps (9/12/2019)

All pumps asserving the desalination system are to be redundant.

3.2.3 Level gauging systems (9/12/2019)

Level gauging systems of tanks containing edible substances are to be so designed as to avoid any contamination of the cargo.

4 Bilge system

4.1 Draining of spaces located inside the cargo area

4.1.1 (9/12/2019)

Connection between the bilge system of engine room and the cargo area, are not permitted. This requirement is in

addition to those given in Pt C, Ch 1, Sec 10, [6] for bilge systems.

4.2 Drip trays in the spaces containing chemical products

4.2.1 (9/12/2019)

Drip trays with adequate drainage to contain possible leakages from chemical products are to be fitted.

Where drain pipes are provided for collecting leakages, they are to be led to an appropriate drain tank.

5 Air pipes

5.1

5.1.1 (9/12/2019)

- a) Air pipes of cargo tanks are to be fitted with automatic closing appliances. Refer to Pt C, Ch 1, Sec 10, [9.1].
- b) Air pipes of tanks containing edible substances are to be located as far away as possible from:
 - air pipes of sewage or flammable oil tanks
 - machinery ventilation outlets.
- c) Air pipes of tanks containing edible substances are to be arranged with mosquito net.

6 Refrigerating installations

6.1

6.1.1 (9/12/2019)

- a) Where the cargo needs to be kept refrigerated for conservation purposes, the refrigerating installation is to comply with the applicable provisions of Part F, Chapter 8.
- b) Provisions are to be made to avoid any contamination of the cargo by the refrigeration fluid.

7 Cargo tanks

7.1 Cargo tank cleaning systems

7.1.1 (9/12/2019)

Adequate means are to be provided for cleaning and sanitization the cargo tanks. In particular when tanks are filled

with sea water before being used for storage of edible substances, procedure are to be provided.

7.1.2 (9/12/2019)

Adequate means are to be provided for preventing stagnation of the cleaning water.

7.2 Cargo tank coating

7.2.1 (9/12/2019)

Cargo tanks coating is to be certified non toxic and suitable for drinking water, according to International Sanitary Rules.

Drip trays with adequate drainage to contain possible leakage from flammable fluid systems are to be fitted.

Where drain pipes are provided for collecting leakages, they are to be led to an appropriate drain tank.

8 Certification, inspection and testing

8.1 Application

8.1.1 (9/12/2019)

The provisions of this Article are related to cargo piping and other equipment fitted in the cargo area. They are additional to those given in Pt C, Ch 1, Sec 10, [21] for piping systems.

8.2 Workshop tests

8.2.1 Tests for materials (9/12/2019)

Where required in Tab 2, materials used for pipes, valves and fittings are to be subjected to the tests specified in Pt C, Ch 1, Sec 10, [21.3.2].

8.2.2 Hydrostatic testing (9/12/2019)

- a) Where required in Tab 2, cargo pipes, valves, fittings and pump casings are to be submitted to hydrostatic tests in accordance with the relevant provisions of Pt C, Ch 1, Sec 10, [21.4].
- b) Expansion joints and cargo hoses are to be submitted to hydrostatic tests in accordance with the relevant provisions off Pt C, Ch 1, Sec 10, [21.4].

8.3 Shipboard tests

8.3.1 Pressure test (9/12/2019)

After installation on board, the cargo piping system is to be checked for leakage under operational conditions.

Table 1 : Documents to be submitted (9/12/2019)

Item No.	A/I	Description of the document (1)
1	I	General plan of the desalination system and specification of all relevant apparatuses
2	A	Schematic arrangement of cargo and desalination system
3	I	Procedure and limiting conditions for desalination treatment, cargo transfer, tank cleaning, gas freeing and ballasting (operation and maintenance manual)
4	A	Diagram of the cargo tank venting system with indication of the outlet position
5	A	Diagram of the bilge and ballast systems serving the spaces located in the cargo area
6	A	Diagram of the cargo refrigerating systems (if any)

Note 1: A = to be submitted for approval in four copies
I = to be submitted for information in duplicate

(1) Documents are also to include, where applicable:

- the (local and remote) control and monitoring systems and automation systems
- the instructions for the operation and maintenance of the piping system concerned (for information).

Table 2 : Inspection and testing at works (9/12/2019)

No.	Item	Tests for materials		Inspections and tests for the products			References
		Y/N (1)	Type of material certificate (2)	during manufacturing (1)	after completion (1) (3)	Type of product certificate (2)	
1	expansion joints and cargo hoses	Y (4)	W	N	Y	C	[8.2.1] [8.2.2]
2	cargo pumps	Y	W	Y	Y (5)	C	[8.2.1] [8.2.2]

(1) Y = required, N = not required.
(2) C = class certificate, W = works' certificate.
(3) includes the checking of the rule characteristics according to the approved drawings.
(4) if metallic.
(5) inspection during manufacturing is to be carried out according to a program approved by the Society.

Part E
Service Notations

Chapter 31

CHEMICAL TANKER - ASSISTED PROPULSION

SECTION 1 GENERAL

SECTION 1 GENERAL

1 General

1.1 Application

1.1.1 (1/1/2021)

For the assignment of the service notation "chemical tanker - assisted propulsion", as defined in Pt A, Ch 1, Sec 2, [4.5.14], the requirements in Chapter 8 are to be applied, reading "chemical tanker" as "chemical tanker assisted propulsion", with the following differences due to the limited navigation and propulsion capabilities:

- a) the following requirements are not applicable:
 - Ch 8, Sec 1, [2]
 - Ch 8, Sec 3, [8]
 - Ch 8, Sec 4, [2]
 - Ch 8, Sec 4, [3.3.2]
 - Ch 8, Sec 4, [4.3.1]
- b) the following additional requirements to be added to Ch 8, Sec 10, [1.4.1] are applicable:
 - However, for locations not covered by such standards, electrical equipment, cables and wiring which do not conform to the standards may be installed in hazardous locations based on a risk assessment to the satisfaction of the Society, to ensure that an equivalent level of safety is assured.

OFFSHORE SUPPORT VESSEL (OSV)

SECTION 1	GENERAL
SECTION 2	HULL AND STABILITY
SECTION 3	MACHINERY AND SYSTEMS
SECTION 4	ELECTRICAL INSTALLATIONS
APPENDIX 1	CERTIFICATION OF THE W2W SYSTEM

SECTION 1

GENERAL

1 General

1.1 Application

1.1.1 (1/1/2022)

Ships complying with the requirements of this Chapter are eligible for the assignment of the service notation **offshore support vessel**, as defined in Pt A, Ch 1, Sec 2, [4.8.11].

1.1.2 (1/1/2022)

Ships dealt with in this Chapter are to comply with the requirements stipulated in Parts A, B, C and D of the Rules, as applicable, and with the requirements of Chapter 15, which are specific to supply vessels.

1.2 Summary table

1.2.1 (1/1/2022)

Tab 1 indicates, for ready reference, the Sections of this Chapter containing specific requirements applicable to offshore support vessel.

Table 1 (1/1/2022)

Main subject	Reference
Ship arrangement	(1)
Hull and stability	Sec 2
Machinery and systems	Sec 3
Electrical installations	Sec 4
Automation	(1)
Fire protection, detection and extinction	(1)
(1) No specific requirements for offshore support vessel are given in this Chapter.	

2 Offshore support vessel with additional service feature W2W

2.1 General

2.1.1 (1/1/2022)

This service feature covers the OSVs equipped with a Walk-to-work (W2W) system such as a motion compensated gangway used for personnel transfer from a mobile unit to an offshore facility (e.g. a wind farm) or to another mobile unit.

The selection of the W2W system depends on several factors, such as the OSV characteristics, the envisaged utilization of the W2W, the expected worst environmental conditions, the design technology, etc.

IMCA Marine Renewable Energy Walk to Work (W2W) Decision Support Tool (IMCA Information Note M01/18) is an example of the decisional process that should be followed when undertaking a new W2W project. It shows that the OSVs and W2W systems may be of various nature, thus in the following some basic requirements are provided, leaving the more specific issues to the ad-hoc process of Technology Qualification (TQ) according to the "Tasneef "Guide for Technology Qualification Processes".

This process is to cover the W2W system in the context of the specific OSV, with special attention to the interfaces between OSV and W2W and to the type of service the W2W is designed for, in the operating conditions that are to be specified up front.

Guidance for the operational aspects of personnel transfer , which can be taken into account during the design phase, can be found in publications like the "Guidance on the Transfer of Personnel to and from OffshoreVessels and Structures" (IMCA HSSE 025, IMCA LR 012, IMCA M 202 - Rev. 2.1).

2.2 Application

2.2.1 (1/1/2022)

OSVs complying with the requirement of this Chapter and equipped with a W2W system certified by the Society according to the "Guide for Technology Qualification Processes" (see App 1) are eligible for the assignment of the service feature **W2W**, as defined in Pt A, Ch 1, Sec 2, [4.8.11].

Note 1: QSCS Classification Society means a Classification Society which is subject to verification of compliance with the IACS Quality System Certification Scheme (QSCS).

2.2.2 (1/1/2022)

Ships dealt with in this Article are to comply with the requirements stipulated in Parts A, B, C and D, as applicable and with the specific requirements in this Chapter for the assignment of the service feature **W2W**.

2.2.3 (1/1/2022)

The **W2W** system is intended as the whole system and equipment.

The service feature covers the following issues:

- the ship's ability to maintain its position during W2W operations,
- the ship's stability during W2W,
- the hull structural arrangements related to the W2W system and relevant lifting appliances,
- the electrical system, the auxiliary systems (pneumatic, hydraulic etc., as applicable) and control system to operate the W2W system.

2.3 Position keeping

2.3.1 (1/1/2022)

The ship is to be able to maintain its position safely during W2W, whatever the means for position keeping (Dynamic Positioning, anchor mooring etc.).

2.4 General safety criteria

2.4.1 (1/1/2022)

The following criteria are additional to those set forth by the Tasneef rules for the classification of ships and take into account the specific arrangement of the W2W gangway.

2.4.2 (1/1/2022)

Any single failure on a critical structural, mechanical (active and passive), electrical, hydraulic, pneumatic, control, hardware or software item of the W2W and on any of its auxiliary systems, including the interfaces with the OSV, is not to lead to a hazardous situation for the personnel, the OSV or the facility connected to it.

Any incipient failure is to rise a timely alarm at the W2W control station. Control systems are to be self-monitoring with relevant timely alarms in case of detected failures.

W2W is not to lose control of its motions in case of loss of any kind of power of the W2W or any of its auxiliaries. Before emergency disconnection (e.g. in case of worsening environmental conditions) an alarm is to alert personnel in

time to allow for the safe evacuation from the gangway to a safe position.

The fulfilment of such safety criteria is to be demonstrated through a FMEA or equivalent method, which also constitutes a part of the risk assessment required by the TQ. Additional availability criteria may be set forth by stakeholders in the TQ process.

2.5 Documents to be submitted

2.5.1 (1/1/2022)

The documents listed in Tab 2 are to be submitted in addition to the documentation requested for the assignment of the additional class notation DP2 or DP3, if applicable (see Pt F, Ch 13, Sec 6).

3 Offshore support vessel with additional service feature WIND TURBINE MAINTENANCE

3.1 Offshore transfer system

3.1.1 (1/1/2022)

Offshore support vessels with additional service feature WIND TURBINE MAINTENANCE equipped with an offshore transfer system to transfer technicians from the ship to the wind turbine are to be assigned with the additional service feature W2W.

Table 2 : Documents to be submitted (1/1/2022)

No.	A/I (1)	Document
1	I	General arrangement of the W2W system
2	A	Hull structures related to the arrangement of the W2W system, showing the interfaces with the ship
3	A	Electrical load analysis of main and emergency source, showing W2W system related loads
4	A	Drawings of electrical equipment arrangement, including single line diagram and its interface with the ship
5	A	Drawings of auxiliary systems necessary for the W2W system operations, as applicable (hydraulic, pneumatic, etc.)
6	A	General philosophy, technical specification and drawings of the control, monitoring and alarm system and of the relevant control stations
7	A	Communication systems
(1) A = to be submitted for approval in four copies I = to be submitted for information in duplicate		

SECTION 2

HULL AND STABILITY

1 Offshore support vessel with additional service feature Walk-to-Work (W2W)

1.1 Intact stability criteria during lifting of W2W equipment

1.1.1 (1/1/2022)

The following intact stability criteria are to be complied with:

- $\theta_c \leq 15^\circ$
- $GZ_C \leq 0,6 GZ_{MAX}$
- $A_1 \geq 0,4 A_{TOT}$

where:

θ_c : Heeling angle of equilibrium, corresponding to the first intersection between heeling and righting arms (see Fig 1)

GZ_C, GZ_{MAX} : Defined in Fig 1

A_1 : Area, in m-rad, contained between the righting lever and the heeling arm curves, measured from the heeling angle θ_c to the heeling angle equal to the lesser of:

- heeling angle θ_R of loss of stability, corresponding to the second intersection between heeling and righting arms (see Fig 1)
- heeling angle θ_F , corresponding to flooding of unprotected openings which may lead to progressive flooding if they are situated

within the range of the positive righting lever curve. Unprotected openings are openings which are not fitted with at least weathertight means of closure (see Fig 1)

A_{TOT} : Total area, in m rad, below the righting lever curve.

In the above formula, the heeling arm, corresponding to equipment lifting, is to be obtained, in m, from the following formula:

$$b = (P_d - Z_z) / \Delta$$

where:

P : Equipment lifting mass, in t

d : Transverse distance, in m, from W2W equipment to the longitudinal plane (see Fig 1)

Z : Mass, in t, of ballast used to right the ship, if applicable (see Fig 1)

z : Transverse distance, in m, of the centre of gravity of Z to the longitudinal plane (see Fig 1)

Δ : Displacement, in t, in the loading condition considered.

The above check is to be carried out considering the most unfavourable situations of equipment lifting combined with the lesser initial metacentric height GM, corrected according to the requirements in Pt B, Ch 3, Sec 2, [4].

The heeling of the unit is not to produce in the lifting devices higher loads than those envisaged by the Manufacturer, generally expected to be 5° in the boom plane and 2° transversally in the case of a crane.

Table 1 : Documents to be submitted (1/1/2022)

No.	I/A (1)	Document
1	I	General arrangement of the W2W system
2	A	Hull structures related to the arrangement of the W2W system, showing the interfaces with the ship
3	A	Electrical load analysis of main and emergency source, showing W2W system related loads
4	I	Plans showing electrical equipment arrangement
5	A	Single line diagrams of communication systems
(1) A = to be submitted for approval, in quadruplicate I = to be submitted for information, in duplicate		

Figure 1 : W2W system stability equipment lifting (1/1/2022)

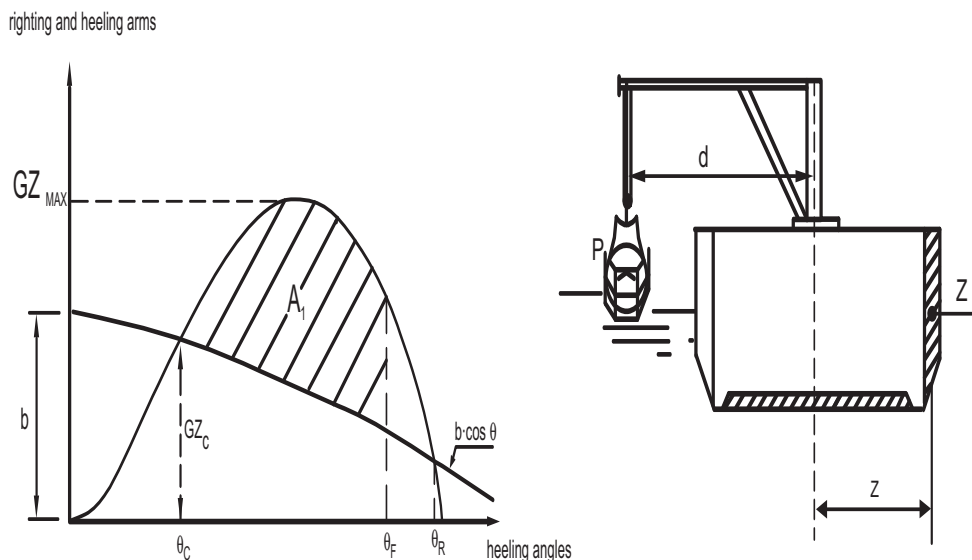

1.2 Hull structural arrangements related to the W2W system

1.2.1 General (1/1/2022)

The hull structures related to the arrangement of the W2W system on the ship are to be designed with adequate strength and stiffness to sustain the loads induced by the system during rest and operation, in accordance with the general load criteria in Part B, Chapter 5 and the strength criteria in Part B, Chapter 8 (or, for ships of $L > 90$ m, Part B, Chapter 7).

Pedestals and foundations also concern the ship's hull and are to comply with the above structural strength requirements.

1.3 Arrangement and installation of the W2W system

1.3.1 Location (1/1/2022)

The W2W is not to be located in spaces containing other machinery or in spaces where explosive gas-air mixtures may be present.

2 Offshore support vessel with additional service feature WIND TURBINE MAINTENANCE

2.1

2.1.1 (1/1/2022)

The hull structural strength is to be as required for the main class taking into account necessary strengthening of supporting structures for equipment applied during the maintenance and service of offshore wind farms.

2.1.2 (1/1/2022)

All load effects caused by deck cargo and heavy equipment are to be accounted for in the design calculations for all operational phases.

SECTION 3

MACHINERY AND SYSTEMS

1 Offshore support vessel with additional service feature WIND TURBINE MAINTENANCE

1.1 Seakeeping

1.1.1 General (1/1/2022)

The ship is to be capable, within given environmental limit conditions, of maintaining the position during operation, either by means of anchoring arrangement or dynamic positioning system.

1.1.2 Dynamic positioning (1/1/2022)

Dynamic positioning system, when used to maintain the vessel's position during operations, is to comply with the requirements for the additional class notation **DYNAPOS** (see Pt F, Ch 13, Sec 6).

1.1.3 Station keeping with anchors and cables (1/1/2022)

Position mooring with anchors, cable and mooring winches are to fulfill the requirements for position mooring system of Part B, Chapter 9 of Rules for the Classification of Floating Offshore Units at Fixed Locations and Mobile Offshore Drilling Units. Safety precautions are to be considered to prevent damaging seabed equipment and installation by deployment, recovery and station keeping.

SECTION 4 ELECTRICAL INSTALLATIONS

1 Offshore support vessel with additional service feature Walk-to-Work (W2W)

1.1 General

1.1.1 (1/1/2022)

For the purpose of W2W, the essential electrical services that need to be in continuous operation to ensure the safe operation of the system at all times are to be taken into account.

A non-exhaustive list of such services is as follows, as applicable.

- Power driven motion compensation system (e.g. dynamic ballast)
- lighting along the W2W system (gangway, platform etc.)
- control, monitoring and alarms
- control stations
- systems that support the W2W motions (hydraulic, pneumatic etc.)
- power driven connection/disconnection systems.

1.2 Main source and emergency source

1.2.1 (1/1/2022)

The essential services mentioned above for the period required to the safe completion of the mission both in normal and emergency conditions are to be supplied from both main and emergency sources of electrical power.

1.3 Distribution systems

1.3.1 (1/1/2022)

Only insulated (IT) electrical distribution systems are permitted to supply a W2W system. Being insulated, they are to be provided with a device capable of automatic insulation monitoring and, in the case of insulation failure, actuating switch-off and giving an alarm.

Alarm only may be used if a sudden switch-off of the equipment may cause danger to the divers.

Systems using double insulated apparatus or earth fault circuit-breakers will be considered on a case-by-case basis.

When the main power to the W2W system is supplied via a distribution board, this board is to be supplied by two separate feeders from different sections of the main switchboard.

When the emergency power to the W2W system is supplied by the ship, the supply is to be from the ship's emergency switchboard.

1.4 Installation

1.4.1 (1/1/2022)

Tensile loads are not to be applied to electrical cables or wiring.

1.5 Communication systems

1.5.1 (1/1/2022)

A communication system is to be arranged for direct two-way communication between the bridge and/or control stations and the W2W system.

APPENDIX 1

CERTIFICATION OF THE W2W SYSTEM

1 General

1.1

1.1.1 (1/1/2022)

As explained in Sec 1, the W2W system is to be certified for fitness of service according to the Tasneef "Guide for Technology Qualification Processes", which is to be applied to the system. Salient points of TQ are the establishment of a team with stakeholders, the agreed definition of qualification basis for the fitness of service, the normative gap analysis, the risk assessment and the engineering activities (analysis and tests) to demonstrate the qualification criteria have been fulfilled.

Some generic guidance is provided in the following, but the actual process is to be developed in full according to the aforesaid Guide for TQ Processes.

- a) To define the qualification basis, first of all the actual design, mission and safety criteria of the W2W need to be appraised, bearing in mind that the first and foremost goal is the safety of the personnel in all operating conditions.

In this regulation, the W2W is assumed to be a gangway to transfer personnel from the OSV to offshore facilities such as wind farms, offshore platforms and the like, built using steel and/or aluminum alloys. It may be fitted on an OSV during her construction, or on an existing vessel, which obviously poses different problems.

Other systems than a gangway may be employed, and this is to be appraised up front.

- b) The OSV, gangway and facility are to be viewed as closely interrelated aspects and particular care is to be given to the physical and operational interfaces; the TQ of a gangway is valid on a specific combinations of such aspects (unless it is demonstrated that the same qualified gangway is used in more benign conditions). The aspects of integration onboard of the supporting OSV are to be appraised, e.g.:

- physical layout of the W2W and its supporting structures and foundations;
- the OSV motions and accelerations in the most severe environmental conditions;
- stability issues during W2W operations in the most severe environmental conditions;
- the station keeping system;
- the power supply, which is at least to be sized to feed simultaneously the station keeping system, the

W2W and its auxiliaries in the worst defined environmental conditions

- the W2W auxiliaries fitted onboard
- the actions on the W2W, in its various operating phases, initiated by the control and automation system in case of emergency scenarios affecting the OSV, the facility, or both.
- the actions on the W2W in a transit loading condition, when W2W is stowed but subject to the most severe wind and ship motion loads.

The studies need to include aspects like the OSV motion response characteristics in the operational sea area, the location of the gangway system on the OSV structures, the W2W system's ability to compensate for motions imposed on it by the OSV, the means of connection to the facility, the OSV station keeping system, the facility motions if it is not a fixed structures, etc.

- c) The gangway scantlings are to consider the maximum number of personnel onboard expected to be involved in the gangway operation for their work, and whether their work includes the transfer of loads through it. Of course, this personnel will be additional to the OSV crew and this number will have to be consistent with the regulatory framework of the OSV.
- d) Careful consideration is to be given to the combination of environmental forces affecting the OSV, the W2W and the facility, to find out the worst case and the maximum operational envelope that still allows safety of operations through the gangway.
- e) Power supply, auxiliary systems, control/monitoring/ alarm and communication system is to be designed taking into account all the scenarios that may affect safety in relation to the W2W mission, e.g. the environmental conditions, single failures, contingency scenarios among OSV, W2W and facility, transfer of stretched personnel etc. according to the basic philosophy of the applicable sections of Part C, Chapter 3.
- f) Particular care needs to be applied to the means of connection to the facility and to the failure modes of its active components or to structural problems e.g. due to excessive motions of the W2W. This latter characteristic is to be taken into account when setting the alarms and the emergency disconnection.
- g) Control stations are to be designed so as to avoid that a single realistic operator error causes the loss of control of the W2W or the unwanted disconnection of the gangway.
- h) Since the W2W system and the OSV are to be seen as a whole, the risk assessment studies required for the TQ, among others, are to cover power supply and auxiliary

systems; in this framework, particular care is to be taken to cover:

- Command systems (mechanical - electromechanical - electrohydraulic - electrical)
- Control systems (electrical/electronic/hydraulic)
- Safety systems (passive and active)
- Interfaces with other OSV systems (ESD - position reference system...)
- emergency scenarios (blackout, fire, flooding etc.)

The results of the risk assessment will then be used to complete the commissioning phase, to set up onboard verification tests to demonstrate that the W2W system is safe in the envisaged normal and abnormal operating conditions.

WIND TURBINE INSTALLATION VESSEL

- SECTION 1 GENERAL**
- SECTION 2 HULL AND STABILITY**
- SECTION 3 MACHINERY AND SYSTEMS**

SECTION 1

GENERAL

1 General

1.1 Application

1.1.1 (1/1/2022)

Ships complying with the requirements of this Chapter are eligible for the assignment of the service notation **wind turbine installation vessel**, as defined in Pt A, Ch 1, Sec 2, [4.8.12].

Wind turbine installation vessel are specially intended for installation and/or maintenance of fixed and floating wind power equipment such as:

- foundations
- columns
- generator house
- blades.

1.1.2 (1/1/2022)

Ships dealt with in this Chapter are to comply with the requirements stipulated in Parts A, B, C and D of the Rules, as applicable, and with the requirements of this Chapter, which are specific for the assignment of the service feature **wind turbine installation vessel**.

1.2 Summary table

1.2.1 (1/1/2022)

Tab 1 indicates, for ready reference, the Sections of this Chapter containing specific requirements applicable to wind turbine Installation vessel.

Table 1 (1/1/2022)

Main subject	Reference
Ship arrangement	(1)
Hull and stability	Sec 2
Machinery and systems	Sec 3
Electrical installations	(1)
Automation	(1)
Fire protection, detection and extinction	(1)
(1) No specific requirements for wind turbine Installation vessel are given in this Chapter.	

2 Wind turbine installation vessel with additional service feature W2W

2.1 General

2.1.1 (1/1/2022)

Wind turbine installation vessels with the additional service feature **W2W** are to comply with applicable requirements in Chapter 32.

SECTION 2

HULL AND STABILITY

1 Special design principles applied to self-elevating units

1.1

1.1.1 (1/1/2022)

For **wind turbine installation vessel** equipped with a self-elevating system, the special design principles of Pt E, Ch 4, Sec 2, [1] and [7] of Tasneef Rules for the Classification of Floating Offshore Units at Fixed Locations and Mobile Off-shore Drilling Units are to be applied.

2 Intact stability criteria

2.1

2.1.1 (1/1/2022)

Intact stability criteria are to be in compliance with Pt E, Ch 4, Sec 3, [4] of Tasneef Rules for the Classification of Floating Offshore Units at Fixed Locations and Mobile Offshore Drilling Units.

3 Subdivision and damage stability

3.1

3.1.1 (1/1/2022)

Subdivision and damage stability are to be in compliance with Pt E, Ch 4, Sec 3, [5.1] of Tasneef Rules for the Classification of Floating Offshore Units at Fixed Locations and Mobile Offshore Drilling Units.

4 Stability and watertight integrity

4.1

4.1.1 (1/1/2022)

Stability and watertight integrity are to be in compliance with Pt E, Ch 4, Sec 3, [6.2] and [7.1.6] of Tasneef Rules for the Classification of Floating Offshore Units at Fixed Locations and Mobile Offshore Drilling Units.

5 Freeboard

5.1

5.1.1 (1/1/2022)

Freeboard is to be in compliance with Pt E, Ch 4, Sec 3, [9.3] of Tasneef Rules for the Classification of Floating Off-shore Units at Fixed Locations and Mobile Offshore Drilling Units.

SECTION 3

MACHINERY AND SYSTEMS

1 Machinery installations for self-elevating units

1.1 General

1.1.1 (1/1/2022)

The requirements of this item apply in lieu of those in Pt C, Ch 1, Sec 1, [2.4].

All machinery, components and systems essential to the safe operation of a unit are to be designed to operate under the following static condition of inclination: when self-elevating units are upright and inclined to an angle up to 10° in any direction.

The Society may permit or require deviations from these angles, taking into consideration the type, size and service conditions of the unit.

1.1.2 (1/1/2022)

Jacking mechanisms for self-elevating units are in general to be arranged with redundancy so that a single failure of any component does not cause an uncontrolled descent of the unit.

1.1.3 (1/1/2022)

Means are to be provided whereby normal operation of vital systems, such as ballast systems in semisubmersible units, jacking systems in self-elevating units or control of blow-out preventers, can be sustained or restored even though one of the essential auxiliaries becomes inoperable.

2 Cranes

2.1

2.1.1 (1/1/2022)

For **wind turbine installation vessel** equipped with cranes intended to be operated offshore, the service notation **lifting unit** is to be complied with, as defined in Pt A, Ch 1, Sec 2.

3 Seakeeping

3.1 General

3.1.1 (1/1/2022)

The ship is to be capable, within given environmental limit conditions, of maintaining the position during operation, either by means of anchoring arrangement or dynamic positioning system.

3.2 Dynamic positioning

3.2.1 (1/1/2022)

Dynamic positioning system, when used to maintain the vessel's position during operations, is to comply with the requirements for the additional class notation **DYNAPOS** (see Pt F, Ch 13, Sec 6).