

# Rules for the Classification of Ships

*Effective from 1 July 2024*

## Part E

Service Notations



## GENERAL CONDITIONS

### Definitions:

**Administration** means the Government of the State whose flag the ship is entitled to fly or under whose authority the ship is authorized to operate in the specific case.

**“IACS”** means the International Association of Classification Societies.

**“Interested Party”** means the party, other than the Society, having an interest in or responsibility for the Ship, product, plant or system subject to classification or certification (such as the owner of the Ship and his representatives, the shipbuilder, the engine builder or the supplier of parts to be tested) who requests the Services or on whose behalf the Services are requested.

**“Owner”** means the registered owner, the shipowner, the manager or any other party with the responsibility, legally or contractually, to keep the ship seaworthy or in service, having particular regard to the provisions relating to the maintenance of class laid down in Part A, Chapter 2 of the Rules for the Classification of Ships or in the corresponding rules indicated in the Specific Rules.

**“Rules”** in these General Conditions means the documents below issued by the Society:

- (i) Rules for the Classification of Ships or other special units.
- (ii) Complementary Rules containing the requirements for product, plant, system and other certification or containing the requirements for the assignment of additional class notations;
- (iii) Rules for the application of statutory rules, containing the rules to perform the duties delegated by Administrations.
- (iv) Guides to carry out particular activities connected with Services;
- (v) Any other technical document, for example, rule variations or interpretations.

**“Services”** means the activities described in paragraph 1 below, rendered by the Society upon request made by or on behalf of the Interested Party.

**“Ship”** means ships, boats, craft and other special units, for example, offshore structures, floating units and underwater craft.

**“Society”** or **“TASNEEF”** means TASNEEF Maritime

**“Surveyor”** means technical staff acting on behalf of the Society in performing the Services.

**“Force Majeure”** means damage to the ship; unforeseen inability of the Society to attend the ship due to government restrictions on right of access or movement of personnel; unforeseeable delays in port or inability to discharge cargo due to unusually lengthy periods of severe weather, strikes or civil strife; acts of war; or other force majeure.

### 1. Society Roles

1.1. The purpose of the Society is, among others, the classification and certification of ships and the certification of their parts and components. In particular, the Society:

- (i) sets forth and develops Rules.
- (ii) publishes the Register of Ships.
- (iii) Issues certificates, statements and reports based on its survey activities.

1.2. The Society also takes part in the implementation of national and international rules and standards as delegated by various Governments.

1.3. The Society carries out technical assistance activities on request and provides special services outside the scope of classification, which is regulated by these general conditions unless expressly excluded in the particular contract.





## 2. Rule Development, Implementation and Selection of Surveyor

2.1. The Rules developed by the Society reflect the level of its technical knowledge at the time they are published therefore, the Society, although also committed through its research and development services to continuous updating of the Rules, does not guarantee the Rules meet state-of-the-art science and technology at the time of publication or that they meet the Society's or others' subsequent technical developments.

2.2. The Interested Party is required to know the Rules based on which the Services are provided. With particular reference to Classification Services, special attention is to be given to the Rules concerning class suspension, withdrawal and reinstatement. In case of doubt or inaccuracy, the Interested Party is to promptly contact the Society for clarification. The Rules for Classification of Ships are published on the Society's website: [www.tasneef.ae](http://www.tasneef.ae).

2.3. Society exercises due care and skill:

(i) In the selection of its Surveyors

(ii) In the performance of its Services, taking into account the level of its technical knowledge at the time the Services are performed.

2.4. Surveys conducted by the Society include, but are not limited to, visual inspection and non-destructive testing. Unless otherwise required, surveys are conducted through sampling techniques and do not consist of comprehensive verification or monitoring of the Ship or the items subject to certification. The surveys and checks made by the Society on board ship do not necessarily require the constant and continuous presence of the Surveyor. The Society may also commission laboratory testing, underwater inspection and other checks carried out by and under the responsibility of qualified service suppliers. Survey practices and procedures are selected by the Society based on its experience and knowledge and according to generally accepted technical standards in the sector.

## 3. Class Report & Interested Parties Obligation

3.1. The class assigned to a Ship, like the reports, statements, certificates or any other document or information issued by the Society, reflects the opinion of the Society concerning compliance, at the time the Service is provided, of the Ship or product subject to certification, with the applicable Rules (given the intended use and within the relevant time frame). The Society is under no obligation to make statements or provide information about elements or facts which are not part of the specific scope of the Service requested by the Interested Party or on its behalf.

3.2. No report, statement, notation on a plan, review, Certificate of Classification, document or information issued or given as part of the Services provided by the Society shall have any legal effect or implication other than a representation that, on the basis of the checks made by the Society, the Ship, structure, materials, equipment, machinery or any other item covered by such document or information meet the Rules. Any such document is issued solely for the use of the Society, its committees and clients or other duly authorized bodies and no other purpose. Therefore, the Society cannot be held liable for any act made or document issued by other parties based on the statements or information given by the Society. The validity, application, meaning and interpretation of a Certificate of Classification, or any other document or information issued by the Society in connection with its Services, is governed by the Rules of the Society, which is the sole subject entitled to make such interpretation. Any disagreement on technical matters between the Interested Party and the Surveyor in the carrying out of his functions shall be raised in writing as soon as possible with the Society, which will settle any divergence of opinion or dispute.

3.3. The classification of a Ship or the issuance of a certificate or other document connected with classification or certification and in general with the performance of Services by the Society shall have the validity conferred upon it by the Rules of the Society at the time of the assignment of class or issuance of the certificate; in no case shall it amount to a statement or warranty of seaworthiness, structural integrity, quality or fitness for a particular purpose or service of any Ship, structure, material, equipment or machinery inspected or tested by the Society.

3.4. Any document issued by the Society about its activities reflects the condition of the Ship or the subject of certification or other activity at the time of the check.

3.5. The Rules, surveys and activities performed by the Society, reports, certificates and other documents issued by the Society are in no way intended to replace the duties and responsibilities of other parties such as Governments, designers, shipbuilders, manufacturers, repairers, suppliers, contractors or sub-contractors, Owners, operators, charterers, underwriters, sellers or intended buyers of a Ship or other product or system surveyed.





These documents and activities do not relieve such parties from any fulfilment, warranty, responsibility, duty or obligation (also of a contractual nature) expressed or implied or in any case incumbent on them, nor do they confer on such parties any right, claim or cause of action against the Society. With particular regard to the duties of the ship Owner, the Services undertaken by the Society do not relieve the Owner of his duty to ensure proper maintenance of the Ship and ensure seaworthiness at all times. Likewise, the Rules, surveys performed, reports, certificates and other documents issued by the Society are intended neither to guarantee the buyers of the Ship, its components or any other surveyed or certified item, nor to relieve the seller of the duties arising out of the law or the contract, regarding the quality, commercial value or characteristics of the item which is the subject of transaction.

In no case, therefore, shall the Society assume the obligations incumbent upon the above-mentioned parties, even when it is consulted in connection with matters not covered by its Rules or other documents.

In consideration of the above, the Interested Party undertakes to relieve and hold harmless the Society from any third-party claim, as well as from any liability about the latter concerning the Services rendered.

Insofar as they are not expressly provided for in these General Conditions, the duties and responsibilities of the Owner and Interested Parties concerning the services rendered by the Society are described in the Rules applicable to the specific service rendered.

#### 4. Service Request & Contract Management

4.1. Any request for the Society's Services shall be submitted in writing and signed by or on behalf of the Interested Party. Such a request will be considered irrevocable as soon as received by the Society and shall entail acceptance by the applicant of all relevant requirements of the Rules, including these General Conditions. Upon acceptance of the written request by the Society, a contract between the Society and the Interested Party is entered into, which is regulated by the present General Conditions.

4.2 In consideration of the Services rendered by the Society, the Interested Party and the person requesting the service shall be jointly liable for the payment of the relevant fees, even if the service is not concluded for any cause not pertaining to the Society. In the latter case, the Society shall not be held liable for non-fulfilment or partial fulfilment of the Services requested.

4.3 The contractor for the classification of a ship or for the services may be terminated and any certificates revoked at the request of one of the parties, subject to at least 30/60/90 days' notice, to be given in writing. Failure to pay, even in part, the fees due for services carried out by the society will entitle the society to immediately terminate the contract and suspend the service.

For every termination of the contract, the fees for the activities performed until the time of the termination shall be owned to the society as well as the expenses incurred in view of activities already programmed, this is without prejudice to the right to compensation due to the society as a consequence of the termination.

With particular reference to ship classification and certification, unless decided otherwise by the society, termination of the contract implies that the assignment of class to a ship is withheld or, if already assigned, that it is suspended or withdrawn, any statutory certificates issued by society will be withdrawn in those cases where provided for by agreements between the society and the flag state.

#### 5. Service Accuracy

5.1. In providing the Services, as well as other correlated information or advice, the Society, its Surveyors, servants or agents operate with due diligence for the proper execution of the activity. However, considering the nature of the activities performed (see **Rule Development, Implementation and Selection of Surveyor 2.4**), it is not possible to guarantee absolute accuracy, correctness and completeness of any information or advice supplied. Express and implied warranties are specifically disclaimed.







## 6. Confidentiality & Document sharing

6.1. All plans, specifications, documents and information provided by, issued by, or made known to the Society, in connection with the performance of its Services, will be treated as confidential and will not be made available to any other party other than the Owner without authorization of the Interested Party, except as provided for or required by any applicable international, European or domestic legislation, Charter or other IACS resolutions, or order from a competent authority. Information about the status and validity of class and statutory certificates, including transfers, changes, suspensions, withdrawals of class, recommendations/conditions of class, operating conditions or restrictions issued against classed ships and other related information, as may be required, may be published on the website or released by other means, without the prior consent of the Interested Party.

Information about the status and validity of other certificates and statements may also be published on the website or released by other means, without the prior consent of the Interested Party.

6.2. Notwithstanding the general duty of confidentiality owed by the Society to its clients in clause 7.1 below, the Society's clients hereby accept that the Society may participate in the IACS Early Warning System which requires each Classification Society to provide other involved Classification Societies with relevant technical information on serious hull structural and engineering systems failures, as defined in the IACS Early Warning System (but not including any drawings relating to the ship which may be the specific property of another party), to enable such useful information to be shared and used to facilitate the proper working of the IACS Early Warning System. The Society will provide its clients with written details of such information sent to the involved Classification Societies.

6.3. In the event of transfer of class, addition of a second class or withdrawal from a double/dual-class, the Interested Party undertakes to provide or to permit the Society to provide the other Classification Society with all building plans and drawings, certificates, documents and information relevant to the classed unit, including its history file, as the other Classification Society may require for classification in compliance with the applicable legislation and relative IACS Procedure. It is the Owner's duty to ensure that, whenever required, the consent of the builder is obtained about the provision of plans and drawings to the new Society, either by way of the appropriate stipulation in the building contract or by other agreement.

In the event that the ownership of the ship, product or system subject to certification is transferred to a new subject, the latter shall have the right to access all pertinent drawings, specifications, documents or information issued by the Society or which has come to the knowledge of the Society while carrying out its Services, even if related to a period prior to transfer of ownership.

## 7. Health, Safety & Environment

7.1. The clients such as the designers, shipbuilders, manufacturers, repairers, suppliers, contractors or sub-contractors, or other product or system surveyed who have a registered office in ABU Dhabi; should have an approved OSHAD as per Abu Dhabi OHS Centre, or, if they do not need to have an approved OSHAD, they shall comply with TASNEEF standards and have procedures in place to manage the risks from their undertakings.

7.2. For the survey, audit and inspection activities onboard the ship, the ship's owner, the owner representative or the shipyard must follow TASNEEF rules regarding the safety aspects.

## 8. Validity of General Conditions

8.1. Should any part of these General Conditions be declared invalid, this will not affect the validity of the remaining provisions.





## 9. Force Majeure

9.1 Neither Party shall be responsible to the other party for any delay or failure to carry out their respective obligations insofar as such delay and failure derives, directly or indirectly, and at any time, from force majeure of any type whatsoever that lies outside the control of either Party.

9.2 The Party that is unable to fulfil the agreement due to Force Majeure shall inform the other party without delay and in all cases within 7 days from when such force majeure arose.

9.3 It is understood that if such force majeure continues for more than 30 days, the Party not affected by the event may terminate this agreement by registered letter. The rights matured until the day in which the force majeure occurred remain unaffected.

## 10. Governing Law and Jurisdiction

This Agreement shall be governed by and construed in accordance with the laws of Abu Dhabi and the applicable Federal Laws of the UAE.

Any dispute arising out of or in accordance with this Agreement shall be subject to the exclusive jurisdiction of the Abu Dhabi courts.

## 11. Code of Business conduct

The **CLIENT** declares to be aware of the laws in force about the responsibility of the legal persons for crimes committed in their interest or to their own advantage by persons who act on their behalf or cooperate with them, such as directors, employees or agents.

In this respect, the **CLIENT** declares to have read and fully understood the "**Ethical Code**" published by **TASNEEF** and available in the **TASNEEF** Web site.

The **CLIENT**, in the relationships with **TASNEEF**, guarantees to refrain from any behaviour that may incur risk of entry in legal proceedings for crimes or offences, whose commission may lead to the enforcement of the laws above.

The **CLIENT** also acknowledges, in case of non-fulfilment of the previous, the right of **TASNEEF** to unilaterally withdraw from the contract/agreement even if there would be a work in progress situation or too early terminate the contract/agreement. It's up to **TASNEEF** to choose between the two above mentioned alternatives, and in both cases a registered letter will be sent with a brief sum-up of the circumstances or of the legal procedures proving the failure in following the requirements of the above-mentioned legislation.

In light of the above, it is forbidden to all employees and co-operators to:

- receive any commission, percentage or benefits of any possible kind;
- Start and maintaining any business relationship with **Clients** that could cause conflict of interests with their task and function covered on behalf of **TASNEEF**.
- Receive gifts, travel tickets or any other kind of benefits different from monetary compensation, that could exceed the ordinary business politeness.

Violation of the above-mentioned principles allows **TASNEEF** to early terminate the contract and to be entitled to claim compensation for losses if any.



## EXPLANATORY NOTE TO PART E

### 1. Reference edition

The reference edition for Part E is the Tasneef Rules 2000 edition, which is effective from 1 June 2000.

### 2. Amendments after the reference edition

2.1 Tasneef Rules 2000 has been completely rewritten and reorganised.

2.2 Except in particular cases, the Rules are updated and published annually.

### 3. Effective date of the requirements

3.1 All requirements in which new or amended provisions with respect to those contained in the reference edition have been introduced are followed by a date shown in brackets.

The date shown in brackets is the effective date of entry into force of the requirements as amended by the last updating. The effective date of all those requirements not followed by any date shown in brackets is that of the reference edition.

3.2 Item 6 below provides a summary of the technical changes from the preceding edition. In general, this list does not include those items to which only editorial changes have been made not affecting the effective date of the requirements contained therein.

### 4. Rule Variations and Corrigenda

Until the next edition of the Rules is published, Rule Variations and/or corrigenda, as necessary, will be published on the Tasneef web site ([www.Tasneef.ae](http://www.Tasneef.ae)). Except in particular cases, paper copies of Rule Variations or corrigenda are not issued.

### 5. Rule subdivision and cross-references

#### 5.1 Rule subdivision

The Rules are subdivided into six parts, from A to F.

Part A: Classification and Surveys

Part B: Hull and Stability

Part C: Machinery, Systems and Fire Protection

Part D: Materials and Welding

Part E: Service Notations

Part F: Additional Class Notations

Each Part consists of:

- Chapters
- Sections and possible Appendices
- Articles
- Sub-articles
- Requirements

Figures (abbr. Fig) and Tables (abbr. Tab) are numbered in ascending order within each Section or Appendix.

#### 5.2 Cross-references

Examples: Pt A, Ch 1, Sec 1, [3.2.1] or Pt A, Ch 1, App 1, [3.2.1]

- Pt A means Part A

The part is indicated when it is different from the part in which the cross-reference appears. Otherwise, it is not indicated.

- Ch 1 means Chapter 1

The Chapter is indicated when it is different from the chapter in which the cross-reference appears. Otherwise, it is not indicated.

- Sec 1 means Section 1 (or App 1 means Appendix 1)

The Section (or Appendix) is indicated when it is different from the Section (or Appendix) in which the cross-reference appears. Otherwise, it is not indicated.

- [3.2.1] refers to requirement 1, within sub-article 2 of article 3.

Cross-references to an entire Part or Chapter are not abbreviated as indicated in the following examples:

- Part A for a cross-reference to Part A
- Part A, Chapter 1 for a cross-reference to Chapter 1 of Part A.

**6. Summary of amendments introduced in the edition effective from 1 July 2024**

**Foreword**

This edition of Part E contains amendments whose effective date is **1 July 2024**.

The date of entry into force of each new or amended item is shown in brackets after the number of the item concerned.



## Part E Service Notations

Chapters 1 2 3 4 5 6 7 **8 9 10 11 12 13 14 15** 16 17 18 19 20 21 22 23 24 25 26 27 28 29 30 31 32 33

---

Chapter 1	RO-RO CARGO SHIPS
Chapter 2	CONTAINER SHIPS
Chapter 3	LIVESTOCK CARRIERS
Chapter 4	BULK CARRIERS
Chapter 5	ORE CARRIERS
Chapter 6	COMBINATION CARRIERS
Chapter 7	OIL TANKERS AND FLS TANKERS
<b>Chapter 8</b>	<b>CHEMICAL TANKERS</b>
<b>Chapter 9</b>	<b>LIQUEFIED GAS CARRIERS</b>
<b>Chapter 10</b>	<b>TANKERS</b>
<b>Chapter 11</b>	<b>PASSENGER SHIPS</b>
<b>Chapter 12</b>	<b>RO-RO PASSENGER SHIPS</b>
<b>Chapter 13</b>	<b>SHIPS FOR DREDGING ACTIVITY</b>
<b>Chapter 14</b>	<b>TUGS</b>
<b>Chapter 15</b>	<b>SUPPLY VESSELS</b>
Chapter 16	FIRE FIGHTING VESSELS
Chapter 17	OIL RECOVERY SHIPS
Chapter 18	CABLE-LAYING UNITS
Chapter 19	NON-PROPELLED UNITS
Chapter 20	FISHING VESSELS
Chapter 21	RESEARCH SHIPS
Chapter 22	PIPE LAYING UNITS
Chapter 23	CEMENT CARRIERS
Chapter 24	COMPRESSED NATURAL GAS (CNG) CARRIERS
Chapter 25	OIL CARRIERS - ASSISTED PROPULSION
Chapter 26	PALM OIL CARRIERS - ASSISTED PROPULSION
Chapter 27	UNITS FOR TRANSHIPMENT OF DRY CARGO IN BULK
Chapter 28	CHEMICAL RECOVERY SHIPS
Chapter 29	WELL STIMULATION SHIPS
Chapter 30	MARINE MOBILE DESALINATION UNIT
Chapter 31	CHEMICAL TANKER - ASSISTED PROPULSION
Chapter 32	OFFSHORE SUPPORT VESSEL (OSV)
Chapter 33	WIND TURBINE INSTALLATION VESSEL



# CHAPTER 8

## CHEMICAL TANKERS

### Section 1 General

1	Scope	33
1.1	Application	
2	Additional requirements	34
2.1	Emergency towing arrangement	
2.2	Steering gear	
3	Documentation to be submitted	34
3.1		

### Section 2 Ship Survival Capability and Location of Cargo Tanks

1	Freeboard and intact stability	36
1.1	Intact stability	
2	Location of cargo tanks	36
2.1	Minimum distance of cargo tanks from shell	
2.2	Suction wells	
3	Flooding assumptions	36
3.1	Tunnels, ducts and pipes in the damaged zone	

### Section 3 Ship Arrangement

1	Cargo segregation	37
1.1	Segregation of cargoes mutually reacting	
1.2	Cargo piping arrangement	
2	Accommodation, service and machinery spaces and control stations	37
2.1	Air intakes and other openings to accommodation spaces	
2.2	Windows, sidescuttles and doors	
3	Cargo pump rooms	37
3.1	General requirement	
3.2	Machinery driven by shafting passing through pump room bulkheads	
4	Fuel tanks in cargo area	38
4.1	Definition	
4.2	Location of fuel tanks in cargo area	
5	Access arrangement	38
5.1	Access to compartments in the cargo area	
5.2	Access to the bow	
6	Bilge and ballast arrangements	39
6.1	Ballast segregation	

6.2	Ballast filling arrangement	
6.3	Bilge	
<b>7</b>	<b>Bow or stern loading and unloading arrangements</b>	<b>40</b>
7.1	Coamings	
<b>8</b>	<b>Hull outfitting</b>	<b>40</b>
8.1	Equipment	

## Section 4 Cargo Containment

<b>1</b>	<b>Structure design principles</b>	<b>41</b>
1.1	Materials	
1.2	Hull structure	
1.3	Bulkhead structure	
<b>2</b>	<b>Hull girder loads</b>	<b>41</b>
2.1	Still water loads	
<b>3</b>	<b>Scantlings of integral tanks</b>	<b>42</b>
3.1	Plating	
3.2	Ordinary stiffeners	
3.3	Primary supporting members	
<b>4</b>	<b>Scantlings of independent tank structures</b>	<b>43</b>
4.1	Plating	
4.2	Ordinary stiffeners	
4.3	Primary supporting members	
<b>5</b>	<b>Supports of independent tanks</b>	<b>43</b>
5.1	Structural arrangement	
5.2	Calculation of reaction forces in way of tank supports	
5.3	Scantlings of independent tank supports and hull structures in way	
<b>6</b>	<b>Other structures</b>	<b>44</b>
6.1	Machinery space	
<b>7</b>	<b>Protection of hull metallic structures</b>	<b>44</b>
7.1	Aluminium coatings	
7.2	Passivation treatment	
<b>8</b>	<b>Construction and testing</b>	<b>44</b>
8.1	Welding and weld connections	
8.2	Special structural details	
8.3	Testing	

## Section 5 Cargo Transfer

<b>1</b>	<b>Piping scantlings</b>	<b>45</b>
1.1	Pipe wall thickness calculation	
<b>2</b>	<b>Piping fabrication and joining details</b>	<b>45</b>
2.1	Pipes not required to be joined by welding	
2.2	Expansion joints	
2.3	Non-destructive testing of welding	



	2.4 Certification, inspection and testing of piping system	
<b>3</b>	<b>Piping arrangements</b>	<b>46</b>
	3.1 Arrangement of cargo piping	
	3.2 Removable piping systems	
<b>4</b>	<b>Cargo transfer control systems</b>	<b>46</b>
	4.1 General	
	4.2 Control, monitoring and alarm devices and cargo control room	
<b>5</b>	<b>Ship's cargo hoses</b>	<b>47</b>
	5.1 Compatibility	
<b>6</b>	<b>Bonding</b>	<b>47</b>
	6.1 Static electricity	
<b>7</b>	<b>Integrated cargo and ballast system</b>	<b>47</b>
	7.1 General	

## **Section 6 Materials for Construction**

<b>1</b>	<b>General</b>	<b>48</b>
	1.1 Material and coating characteristics	

## **Section 7 Cargo Temperature Control**

<b>1</b>	<b>General</b>	<b>49</b>
	1.1 Cargo heating and cooling systems	
	1.2 Valves and other fittings	
	1.3 Cargo temperature measuring system	
	1.4 Requirements for special products	

## **Section 8 Cargo Tank Venting and Gas-Freeing Arrangements**

<b>1</b>	<b>Cargo tank venting</b>	<b>51</b>
	1.1 Venting system drainage	
<b>2</b>	<b>Types of tank venting system</b>	<b>51</b>
	2.1 Position of vent outlets	
<b>3</b>	<b>Cargo tank gas-freeing</b>	<b>51</b>
	3.1 Fans	

## **Section 9 Environmental Control**

<b>1</b>	<b>General</b>	<b>52</b>
	1.1 Control by inerting or padding	
	1.2 Control by drying	
	1.3 Special requirements for inert gas systems on chemical carriers	
	1.4 Ventilation	

## **Section 10 Electrical Installations**

<b>1</b>	<b>General</b>	<b>54</b>
1.1	Application	
1.2	Documentation to be submitted	
1.3	System of supply	
1.4	Electrical equipment	
1.5	Earth detection	
1.6	Precautions against inlet of gases or vapours	
1.7	Electrical equipment permitted in hazardous areas	
<b>2</b>	<b>Special requirements for chemical tankers carrying flammable liquids having a flashpoint not exceeding 60°C</b>	<b>55</b>
2.1	Hazardous area classification	
<b>3</b>	<b>Special requirements for chemical tankers carrying flammable liquids having a flashpoint exceeding 60°C</b>	<b>55</b>
3.1	Hazardous area classification	
3.2	Cargoes heated to a temperature above their flashpoint and cargoes heated to a temperature within 15°C of their flashpoint	

## **Section 11 Fire Protection and Fire Extinction**

<b>1</b>	<b>General</b>	<b>56</b>
1.1		

## **Section 12 Mechanical Ventilation in the Cargo Area**

<b>1</b>	<b>Spaces normally entered during cargo handling operations</b>	<b>57</b>
1.1	Miscellaneous requirements	
1.2	Additional requirements for non-sparking fans	
<b>2</b>	<b>Pump rooms and other enclosed spaces normally entered</b>	<b>58</b>
2.1	Clarification of general requirement	
<b>3</b>	<b>Spaces not normally entered</b>	<b>58</b>
3.1	Portable fans	

## **Section 13 Instrumentation**

<b>1</b>	<b>Gauging</b>	<b>59</b>
1.1	Types of gauging devices	
<b>2</b>	<b>Vapour detection</b>	<b>59</b>
2.1	Vapour detection instruments	
2.2	Gas Measurements	

## **Section 14 Protection of Personnel**

1	General	60
	1.1	

## **Section 15 Special Requirements**

1	Ammonium nitrate solution (93% or less)	61
	1.1 Ammonia injection	
	1.2 Cargo pumps	
2	Hydrogen peroxide solutions	61
	2.1 Hydrogen peroxide solutions over 60% but not over 70%	
3	Propylene oxide and mixtures of ethylene oxide/propylene oxide with an ethylene oxide content of not more than 30% by mass	61
	3.1 Tank cleaning	
	3.2 Joints in cargo lines	
	3.3 Oxygen content in tank vapour spaces	
	3.4 Valves at cargo hose connections	
4	Sulphur (molten)	62
	4.1 Fire-fighting system	
5	Acids	62
	5.1 Lining	
	5.2 Electrical arrangements	
	5.3 Leak detection system	
6	Toxic products	62
	6.1 Return line to shore installation	
7	Cargoes protected by additives	62
	7.1 Prevention of blockage by polymerisation	
8	Cargoes with a vapour pressure greater than 0,1013 MPa (1,013 bar) absolute at 37,8°C	62
	8.1 General	
	8.2 Return of expelled gases	
9	Special cargo pump room requirements	62
	9.1 Clarification	
10	Overflow control	63
	10.1 Independence of systems	

## **Section 16 Operational Requirements and Additional Measures for the Protection of the Marine Environment**

1	General	64
	1.1	

<b>Section 17</b>	<b>Summary of Minimum Requirements</b>	
1	General	65
	1.1	
<b>Section 18</b>	<b>List of Chemicals to Which This Chapter Does Not Apply</b>	
1	General	66
	1.1	
<b>Section 19</b>	<b>Index of Products Carried in Bulk</b>	
1	General	67
	1.1	
<b>Section 20</b>	<b>Transport of Liquid Chemical Wastes</b>	
1	General	68
	1.1	
<b>Section 21</b>	<b>Criteria for Assigning Carriage Requirements for Products Subject to the IBC Code</b>	
1	General	69
	1.1	



# CHAPTER 9

## LIQUEFIED GAS CARRIERS

### Section 1 General

1	Scope	73
1.1	Applicability	
2	Additional requirements	74
2.1	Emergency towing arrangement	
2.2	Steering gear	
3	Documentation to be submitted	74
3.1		
4	Cargo equipment trials	74
4.1	Scope	
4.2	Extent of the tests	
5	Construction and testing	76
5.1		

### Section 2 Ship Survival Capabilities and Location of Cargo Tanks

1	Freeboard and intact stability	77
1.1	Intact stability	

### Section 3 Ship Arrangement

1	Segregation of the cargo area	78
1.1	Segregation of hold spaces	
2	Accommodation, service and machinery spaces and control stations	78
2.1	General	
3	Cargo pump rooms and cargo compressor rooms	78
3.1	Location of cargo pump rooms and cargo compressor rooms	
4	Access arrangement	78
4.1	Access to compartments in the cargo area	
4.2	Access to the bow	
5	Air-locks	79
5.1	Arrangement	
5.2	Alarm	
5.3	Electrical equipment	
5.4	Ventilation	
6	Bilge, ballast and fuel oil arrangements	80
6.1	Drainage arrangement	

	6.2	Additional requirements relative to the bilge system	
<b>7</b>		<b>Bow or stern loading and unloading arrangements</b>	<b>80</b>
	7.1	Locations of stopping devices for cargo pumps and compressors	
<b>8</b>		<b>Hull outfitting</b>	<b>80</b>
	8.1	Equipment	

## **Section 4 Cargo Containment**

<b>1</b>		<b>Definitions</b>	<b>81</b>
	1.1	Design pressure in harbour conditions	
	1.2	Design temperature	
<b>2</b>		<b>Design loads</b>	<b>81</b>
	2.1	Internal pressure for integral tanks, membrane tanks and type A independent tanks	
	2.2	Internal pressure for type B and C independent tanks	
<b>3</b>		<b>Hull scantlings</b>	<b>82</b>
	3.1	Plating	
	3.2	Ordinary stiffeners	
	3.3	Primary supporting members	
<b>4</b>		<b>Structural analysis of integral tanks</b>	<b>83</b>
	4.1	Scantlings	
<b>5</b>		<b>Structural analysis of membrane tanks</b>	<b>83</b>
	5.1	General	
	5.2	Scantlings	
<b>6</b>		<b>Structural analysis of type A independent tanks</b>	<b>84</b>
	6.1	Scantlings	
<b>7</b>		<b>Structural analysis of type B independent tanks</b>	<b>84</b>
	7.1	Plating and ordinary stiffeners	
	7.2	Primary supporting members	
	7.3	Fatigue analysis	
	7.4	Crack propagation analysis	
<b>8</b>		<b>Structural analysis of type C independent tanks</b>	<b>87</b>
	8.1	Stiffening rings in way of tank supports	
<b>9</b>		<b>Supports</b>	<b>88</b>
	9.1	Structural arrangement	
	9.2	Calculation of reaction forces in way of tank supports	
	9.3	Keys	
	9.4	Scantlings of type C independent tank supports and hull structures in way	
<b>10</b>		<b>Secondary barrier</b>	<b>89</b>
	10.1	Secondary barrier extent	
<b>11</b>		<b>Insulation</b>	<b>89</b>
	11.1	Heating of structures	

12	<b>Materials</b>	89
	12.1 Insulation material characteristics	
13	<b>Construction and testing</b>	89
	13.1 Weld joint design	
	13.2 Integral tank testing	
	13.3 Membrane and semi-membrane tanks testing	
	13.4 Independent tank testing	
	13.5 Final tests	
14	<b>Structural details</b>	90
	14.1 Special structural details	
	14.2 Connections of the inner hull plating with intermediate plating	
	14.3 Connections of inner bottom with transverse cofferdam bulkheads	
	14.4 Cut-outs and connections	

## **Section 5 Process Pressure Vessels and Liquid, Vapour and Pressure Piping Systems**

1	<b>General</b>	92
	1.1 Process pressure vessels	
2	<b>Cargo and process piping</b>	92
	2.1 General	
	2.2 Scantlings based on internal pressure	
	2.3 Design pressure	
	2.4 Permissible stress	
	2.5 Stress analysis	
	2.6 Materials	
	2.7 Piping fabrication and joining details	
	2.8 Welding, post-weld heat treatment and non-destructive testing	
3	<b>Tests of piping components and pumps prior to installation on board</b>	94
	3.1 Valves	
	3.2 Cargo Pumps	
4	<b>Cargo system valving requirements</b>	95
	4.1 Cargo tank connections for gauging	
	4.2 Emergency shutdown	
5	<b>Cargo transfer methods</b>	96
	5.1 Discharge into common header	
6	<b>Bonding</b>	96
	6.1 Static electricity	
7	<b>Integrated cargo and ballast system</b>	96
	7.1 General	

## **Section 6 Materials for Construction**

1	<b>Material requirements</b>	97
	1.1 Tubes, forgings and castings for cargo and process piping	

	1.2	Aluminium coatings	
<b>2</b>		<b>Welding and non-destructive testing</b>	<b>97</b>
	2.1	Welding consumables	
	2.2	Test requirements	
<b>3</b>		<b>Steels for hull structure</b>	<b>97</b>
	3.1	Grades of steel	

## **Section 7 Cargo Pressure/Temperature Control**

<b>1</b>		<b>General</b>	<b>99</b>
	1.1		

## **Section 8 Cargo Tank Venting System**

<b>1</b>		<b>Pressure relief systems</b>	<b>100</b>
	1.1	Cargo tank	
	1.2	Interbarrier spaces	
	1.3	Vents	
	1.4	Segregation of vents	
<b>2</b>		<b>Additional pressure relieving system for liquid level control</b>	<b>101</b>
	2.1	General	

## **Section 9 Environmental Control**

<b>1</b>		<b>Inerting</b>	<b>102</b>
	1.1	General	
<b>2</b>		<b>Inert gas production on board</b>	<b>102</b>
	2.1	Exemptions	

## **Section 10 Electrical Installations**

<b>1</b>		<b>General</b>	<b>103</b>
	1.1	Application	
	1.2	Documentation to be submitted	
	1.3	System of supply	
	1.4	Earth detection	
	1.5	Precautions against inlet of gases or vapours	
	1.6	Electrical equipment permitted in hazardous areas	
<b>2</b>		<b>Hazardous locations</b>	<b>103</b>
	2.1	Hazardous area classification	
	2.2	Submerged cargo pumps	
<b>3</b>		<b>Product classification</b>	<b>104</b>
	3.1	Temperature class and explosion group	



## **Section 11 Fire Protection and Fire Extinction**

1	General	107
	1.1	

## **Section 12 Mechanical Ventilation in the Cargo Area**

1	Spaces required to be entered during normal cargo handling operations	108
	1.1	Location of discharges from dangerous spaces
	1.2	Recirculation prevention
	1.3	Additional requirements for non-sparking fans
2	Spaces not normally entered	108
	2.1	General requirements

## **Section 13 Instrumentation (Gauging, Gas Detection)**

1	General	109
	1.1	Cargo tank instrumentation
	1.2	Detection of leak through secondary barrier
	1.3	Indicator location
2	Level indicators for cargo tanks	110
	2.1	General
3	Overflow control	110
	3.1	Overflow alarm and shutdown
4	Pressure gauges	110
	4.1	Pressure gauges in cargo tanks
5	Temperature indicating devices	110
	5.1	General
6	Gas detection requirements	110
	6.1	Gas Measurements
	6.2	Position of sampling heads
	6.3	Gas sampling lines
	6.4	Protected spaces
	6.5	Portable gas detectors

## **Section 14 Protection of Personnel**

1	Personnel protection requirements for individual products	111
	1.1	Showers and eye wash

## **Section 15 Filling Limits for Cargo Tanks**

<b>1</b>	<b>General</b>	<b>112</b>
	1.1	

## **Section 16 Use of Cargo as Fuel**

<b>1</b>	<b>Gas fuel supply</b>	<b>113</b>
	1.1 Piping	
	1.2 Valves	
<b>2</b>	<b>Gas fuel plant and related storage tanks</b>	<b>113</b>
	2.1 General	
	2.2 Compressors	
	2.3 Heaters	
<b>3</b>	<b>Special requirements for main boilers</b>	<b>114</b>
	3.1 Boiler arrangement	
	3.2 Combustion chamber	
	3.3 Burner system	
<b>4</b>	<b>Special requirements for gas fired internal combustion engines and gas fired turbines</b>	<b>114</b>
	4.1 Gas fuel supply to engine	
	4.2 Gas fuel supply piping systems	
	4.3 Shut-off of gas fuel supply	
	4.4 Emergency stop of dual fuel engines	
	4.5 Requirements on dual fuel engines	

## **Section 17 Special Requirements**

<b>1</b>	<b>Materials for construction</b>	<b>116</b>
	1.1 Materials exposed to cargo	
<b>2</b>	<b>Inhibition</b>	<b>116</b>
	2.1 Polymerisation prevention - Alternative requirement	
<b>3</b>	<b>Chlorine</b>	<b>116</b>
	3.1 Cargo containment system	
	3.2 Cargo piping system	
	3.3 Instrumentation - Safety devices	
	3.4 Protection of personnel	
	3.5 Filling limits for cargo tanks	

## **Section 18 Operating Requirements**

<b>1</b>	<b>General</b>	<b>117</b>
	1.1	

## Section 19 Summary of Minimum Requirements

1	Additional information on products	118
---	------------------------------------	-----

---

1.1

## Appendix 1 LNG Bunker Ships

1	General	119
---	---------	-----

---

1.1 Application

1.2 Scope

2	Definitions	119
---	-------------	-----

---

2.1 Bunker emergency shut-down system (ESD)

2.2 Bunkering connections

2.3 Custody Transfer Measuring system

2.4 Emergency release coupling (ERC) or breakaway coupling (BRC)

2.5 ESD link system or Ship-ship link (SSL)

2.6 LNG bunkering station

2.7 LNG transfer system

2.8 MID

2.9 OIML R117-1

2.10 Pendant

2.11 Quick connect and disconnect coupling (QCDC)

2.12 Safety zone

2.13 Transfer arm

3	Document to be submitted	120
---	--------------------------	-----

---

3.1 General

4	General design requirements	121
---	-----------------------------	-----

---

4.1 Risk Assessment

4.2 Hazardous area

4.3 Materials

4.4 Arrangement of bunkering system

4.5 Mooring and fendering

5	Hoses and pumps	123
---	-----------------	-----

---

5.1 Hose design requirements

5.2 Type approval, testing and certification of LNG bunkering hoses

5.3 Testing of Hoses at workshop

5.4 Hoses documentation

5.5 Marking of products

5.6 Transfer pumps

6	Quick connect disconnect coupler (QCDC)	124
---	---	-----

---

6.1 Type approval, testing and certification of QCDC

6.2 Type testing

6.3 Workshop testing

7	Emergency release coupling (ERC)	125
---	----------------------------------	-----

---

7.1 Type approval, testing and certification of QCDC

7.2 Type approval, testing and certification of ERC

7.3 Type testing

7.4 Workshop testing

<b>8</b>	<b>Electrical insulation flanges</b>	<b>125</b>
	8.1 General	
<b>9</b>	<b>Hose Supports and transfer arms</b>	<b>125</b>
	9.1 General	
	9.2 Transfer arms	
<b>10</b>	<b>Inert Gas System</b>	<b>126</b>
	10.1	
<b>11</b>	<b>Gas detection</b>	<b>126</b>
	11.1 Gas detection in enclosed spaces	
	11.2 Gas detection in open spaces	
<b>12</b>	<b>Control and safety systems</b>	<b>126</b>
	12.1 General	
	12.2 Emergency shut-down systems (ESD)	
	12.3 Alarms and safety actions	
	12.4 Communication systems	
<b>13</b>	<b>Testing of the LNG transfer system at workshop</b>	<b>128</b>
	13.1 Pressure test	
	13.2 Inspection of welds	
<b>14</b>	<b>Testing and trials of the LNG transfer system at yard</b>	<b>128</b>
	14.1	
	14.2 Piping leak test	
	14.3 Inerting	
<b>15</b>	<b>Implementation survey</b>	<b>129</b>
	15.1	
<b>16</b>	<b>Additional features</b>	<b>129</b>
	16.1 IG-Bunker (Inert Gas Bunker)	
	16.2 BT (Bunker Trust)	
	16.3 VCS-Bunker (Vapour Control System Bunker)	
	16.4 NH3 Tank Ready and NH3 Tank	

## **Appendix 2 Regasification Systems, Process Pressure Vessels and Liquid, Vapour and Pressure Piping Systems**

<b>1</b>	<b>Regasification systems</b>	<b>131</b>
	1.1 General	
	1.2 Design and construction	
	1.3 Documentation to be submitted	
<b>2</b>	<b>Process pressure vessels</b>	<b>131</b>
	2.1	
<b>3</b>	<b>Regasification process piping</b>	<b>131</b>
	3.1	
	3.2 Design pressure	
	3.3 Flanges	

	3.4	Stress analysis	
	3.5	Aluminised pipes	
<b>4</b>		<b>Cargo system valving requirements</b>	<b>133</b>
	4.1	Cargo tank connections for gauging	
	4.2	Emergency shutdown	
<b>5</b>		<b>Cargo transfer methods</b>	<b>133</b>
	5.1	Discharge into common header	
<b>6</b>		<b>Bonding</b>	<b>133</b>
	6.1	Static electricity	
<b>7</b>		<b>MATERIALS FOR CONSTRUCTION</b>	<b>134</b>
	7.1	Material requirements	
	7.2	Welding and non-destructive testing	
<b>8</b>		<b>Electrical installations</b>	<b>134</b>
	8.1	General	
	8.2	Hazardous location classification and permitted electrical equipment	
	8.3	Process plant location classification and permitted electrical equipment	
<b>9</b>		<b>Safety system and fire protection</b>	<b>134</b>
	9.1	General requirements and definitions	
	9.2	Basic design principles	
<b>10</b>		<b>Instrumentation (gauging, gas detection)</b>	<b>135</b>
	10.1	Indicator location	
	10.2	Protected spaces	

# CHAPTER 10

## TANKERS

### Section 1 General

1	General	139
1.1	Application	
1.2	Summary table	

### Section 2 Hull and Stability

1	General arrangement design	140
1.1	Compartment arrangement	
2	Stability	140
2.1	Intact stability	
3	Structure design principles	140
3.1	Materials	
4	Design loads	140
4.1	Hull girder loads	
5	Hull scantlings	140
5.1	Plating	
5.2	Ordinary stiffeners	
5.3	Primary supporting members	
5.4	Scantlings of independent tank structure	
5.5	Strength check with respect to stresses due to the temperature gradient	
6	Other structures	141
6.1	Machinery space	
7	Protection of hull metallic structures	141
7.1	Coating of tank shells	

### Section 3 Machinery and Cargo Systems

1	General	142
1.1	Documents to be submitted	
2	Piping systems	142
2.1	General	
2.2	Cargo piping and pumping	
2.3	Air pipes	
2.4	Refrigerating installations	
2.5	Cargo tank cleaning systems	
2.6	Additional requirements for ships carrying category Z substances	
2.7	Integrated cargo and ballast system	

# CHAPTER 11

## PASSENGER SHIPS

### Section 1 General

1	General	147
1.1	Application	
1.2	Summary table	

### Section 2 Ship Arrangement

1	General	148
1.1	Definitions	
2	General arrangement design	148
2.1	Arrangement of the collision bulkhead	
2.2	After peak bulkhead, machinery space bulkheads and sterntubes	
2.3	Openings in watertight bulkheads below the bulkhead deck	
2.4	Openings in bulkheads above the bulkhead deck	
2.5	Doors	
2.6	Compartment arrangement	

### Section 3 Hull and Stability

1	Stability	154
1.1	Intact stability	
2	Structure design principles	155
2.1	Hull structure	
3	Hull girder strength	155
3.1	Basic criteria	
4	Hull scantlings	156
4.1	Plating	
5	Other structures	156
5.1	Side doors and stern doors	
6	Hull outfitting	158
6.1	Equipment	
7	Windows and sidescuttles	158
7.1	Application	
7.2	Thickness of glasses	
7.3	Alternative to deadlights/storm covers	
8	External glass balustrades	160
8.1	Application	
8.2	Design considerations	

- 8.3 Balustrade glasses
- 8.4 Balustrade stanchions minimum requirements
- 8.5 Balustrade top rail minimum requirements
- 8.6 Glass supporting structures yielding check
- 8.7 Impact Resistance and Containment

## Section 4 Machinery and Systems

<b>1</b>	<b>Bilge system</b>	<b>162</b>
	1.1 General	
	1.2 Bilge pumps	
	1.3 Direct bilge suction	
	1.4 Control location	
	1.5 Provision against bilge system damage	
	1.6 Bilge system for small ships	
<b>2</b>	<b>Ballast system</b>	<b>163</b>
	2.1	
<b>3</b>	<b>Miscellaneous requirements</b>	<b>163</b>
	3.1 Steering gear	
	3.2 Oil-level gauges	
	3.3 Watertight doors	

## Section 5 Electrical Installations

<b>1</b>	<b>General</b>	<b>164</b>
	1.1 Application	
	1.2 Documentation to be submitted	
	1.3 Electrical distribution and protection	
<b>2</b>	<b>Emergency source of electrical power and emergency installations</b>	<b>164</b>
	2.1 General	
	2.2 Distribution of electrical power	
<b>3</b>	<b>General emergency alarm and public address systems</b>	<b>167</b>
	3.1 Application	
	3.2 General emergency alarm system	
	3.3 Public address system	
	3.4 Combined general emergency alarm - Public address system	
<b>4</b>	<b>Installation</b>	<b>168</b>
	4.1 Section and distribution boards	
<b>5</b>	<b>Type approved components</b>	<b>168</b>
	5.1	



# CHAPTER 12

## RO-RO PASSENGER SHIPS

### Section 1 General

1	General	171
1.1	Application	
1.2	Summary table	

### Section 2 Ship Arrangement

1	General	172
1.1	Application	
1.2	Definitions	
2	General arrangement design	172
2.1	Number and disposition of transverse watertight bulkheads	
2.2	Arrangement of the collision bulkhead	
2.3	After peak bulkhead, machinery space bulkheads and sterntubes	
2.4	Openings in watertight bulkheads below the bulkhead deck	
2.5	Openings in bulkheads above the bulkhead deck	
2.6	Doors	
2.7	Integrity of the hull and superstructure, damage prevention and control	
2.8	Compartment arrangement	
3	Patrolling and monitoring	178
3.1	Ro-ro spaces and special category spaces	

### Section 3 Hull and Stability

1	Stability	179
1.1	Intact stability	
2	Structure design principles	179
2.1	General	
2.2	Hull structure	
3	Design loads	179
3.1	Wheeled loads	
3.2	Accommodation	
4	Hull girder strength	180
4.1	Basic criteria	
5	Hull scantlings	180
5.1	Plating	
5.2	Ordinary stiffeners	
5.3	Primary supporting members	

<b>6</b>	<b>Other structures</b>	<b>181</b>
6.1	Superstructures and deckhouses	
6.2	Bow doors and inner doors	
6.3	Side doors and stern doors	
6.4	Movable decks and inner ramps	
6.5	External ramps	
<b>7</b>	<b>Hull outfitting</b>	<b>183</b>
7.1	Equipment	

## **Section 4 Machinery and Systems**

<b>1</b>	<b>Application</b>	<b>184</b>
1.1		
<b>2</b>	<b>Bilge system</b>	<b>184</b>
2.1	General	
<b>3</b>	<b>Scuppers and sanitary discharges</b>	<b>184</b>
3.1	Drainage of vehicle, ro-ro spaces and special category spaces intended for the carriage of motor vehicles with fuel in their tanks for their own propulsion	
3.2	Scupper draining	
<b>4</b>	<b>Sounding pipes</b>	<b>184</b>
4.1	General	

## **Section 5 Electrical Installations**

<b>1</b>	<b>General</b>	<b>185</b>
1.1	Documentation to be submitted	
1.2	Safety characteristics	
<b>2</b>	<b>Supplementary emergency lighting</b>	<b>185</b>
2.1		
<b>3</b>	<b>Installation</b>	<b>185</b>
3.1	Installations in special category spaces situated above the bulkhead deck	
3.2	Installations in special category spaces situated below the bulkhead deck	
3.3	Installations in cargo spaces other than special category spaces intended for the carriage of motor vehicles	
<b>4</b>	<b>Type approved components</b>	<b>186</b>
4.1		

# CHAPTER 13

## SHIPS FOR DREDGING ACTIVITY

### Section 1 General

1	General	191
1.1	Application	
1.2	Summary table	

### Section 2 Hull and Stability

1	Stability	192
1.1	Intact stability	
2	Structure design principles	195
2.1	General	
2.2	Longitudinal members in the area of the hopper well	
2.3	Transverse members in the area of the hopper well	
2.4	Arrangements relating to suction pipes	
2.5	Chafing areas	
2.6	Reinforcements for grounding	
2.7	Bolted structures	
3	Design loads	198
3.1	General	
3.2	Still water hull girder loads	
3.3	Wave hull girder loads	
3.4	Additional hull girder loads for split hopper dredgers and split hopper units	
3.5	Internal pressures for hopper well in dredging situation	
4	Hull girder strength	202
4.1	General	
4.2	Section modulus	
5	Additional requirements for hull girder strength of split hopper dredgers and split hopper units	203
5.1	General	
5.2	Definitions	
5.3	Hull girder stress	
5.4	Checking criteria	
6	Hull scantlings	204
6.1	General	
6.2	Minimum net thicknesses of plating	
6.3	Bottom plating	
6.4	Well bulkhead and cellular keel platings	
6.5	Transversely framed bottoms	
6.6	Buckling check of plating and ordinary stiffeners for split hopper dredgers and split hopper units	
7	Hopper dredgers and hopper units: checking of hopper well structure	204
7.1	General	

7.2	Floors	
7.3	Strong beams at deck level	
7.4	Brackets for trunks	
7.5	Girders supporting the hydraulic cylinder in the hopper spaces (bottom door types 1, 2 and 3)	
<b>8</b>	<b>Split hopper dredgers and split hopper units: superstructure hinges</b>	<b>210</b>
8.1	General	
8.2	Arrangements	
8.3	Materials used for the hinges	
8.4	Forces	
8.5	Scantlings of the hinges	
<b>9</b>	<b>Split hopper dredgers and split hopper units: decks hinges, hydraulic jack connections and chocks</b>	<b>214</b>
9.1	General	
9.2	Arrangements	
9.3	Static forces	
9.4	Dynamic forces	
9.5	Scantlings	
<b>10</b>	<b>Split hopper dredgers and split hopper units: hydraulic jacks and associated piping systems</b>	<b>216</b>
10.1	General	
10.2	Definitions	
10.3	Arrangements	
10.4	Scantling of jacks	
10.5	Inspection and testing	
10.6	Relief valve setting	
<b>11</b>	<b>Rudders</b>	<b>217</b>
11.1	General	
11.2	Additional requirements for split hopper dredgers and split hopper units	
<b>12</b>	<b>Equipment</b>	<b>217</b>
12.1	General	
12.2	Additional requirements for split hopper dredgers and split hopper units	
12.3	Towlines and mooring lines	

### **Section 3 Machinery and Dredging Systems**

<b>1</b>	<b>General</b>	<b>221</b>
1.1	Application	
1.2	Documents to be submitted	
<b>2</b>	<b>Dredging system</b>	<b>221</b>
2.1	General	
2.2	Design of the dredging system components	
2.3	Attachment of dredging equipment to the hull	
<b>3</b>	<b>Steering gear of split hopper dredgers and split hopper units</b>	<b>222</b>
3.1	General	
3.2	Design of the steering gear	
3.3	Synchronisation	

- 4.1 Workshop testing
- 4.2 On board testing

# CHAPTER 14

## TUGS

### Section 1 General

1	General	225
1.1	Application	
1.2	Summary table	

### Section 2 Hull and Stability

1	General	226
1.1	Application	
2	Tugs, salvage tugs and escort tugs	226
2.1	General	
2.2	Stability	
2.3	Structure design principles	
2.4	Hull scantlings	
2.5	Other structures	
2.6	Rudder and bulwarks	
2.7	Equipment	
2.8	Towing arrangements	
2.9	Test requirements	
2.10	Construction and testing	
2.11	Additional arrangements and equipment for tugs with additional service feature "rescue"	
2.12	Additional arrangements and equipment for tugs with additional service feature "standby vessel"	
3	Additional requirements for salvage tugs	234
3.1	General	
3.2	Equipment	
4	Additional requirements for escort tugs	234
4.1	General	
4.2	Stability	
4.3	Structural design principles	
4.4	Equipment	
4.5	Full-scale tests	
4.6	Alternative to full-scale tests	
4.7	Inclinometer	

### Section 3 Integrated Tug/Barge Combination

1	General	239
1.1	Application	
1.2	Permanent connections	
1.3	Removable connections	

<b>2</b>	<b>General arrangement design</b>	<b>239</b>
2.1	Bulkhead arrangement	
<b>3</b>	<b>Integrated tug/barge combinations with permanent connection: stability, freeboard, design loads, hull scantlings and equipment</b>	<b>240</b>
3.1	Stability calculations	
3.2	Freeboard calculation	
3.3	Still water hull girder loads	
3.4	Wave hull girder loads	
3.5	Still water local loads	
3.6	Wave local loads	
3.7	Hull girder strength	
3.8	Scantlings of plating, ordinary stiffeners and primary supporting members	
3.9	Equipment	
<b>4</b>	<b>Integrated tug/barge combination with removable connection: stability, freeboard, design loads, hull scantlings and equipment</b>	<b>241</b>
4.1	Stability calculations	
4.2	Freeboard calculation	
4.3	Still water hull girder loads	
4.4	Wave hull girder loads	
4.5	Still water local loads	
4.6	Wave local loads	
4.7	Hull girder strength	
4.8	Scantlings of plating, ordinary stiffeners and primary supporting members	
4.9	Equipment	
<b>5</b>	<b>Connection</b>	<b>242</b>
5.1	General	
5.2	Scantlings	
<b>6</b>	<b>Other structures</b>	<b>242</b>
6.1	Tug fore part	
6.2	Tug aft part	
6.3	Barge fore part	
6.4	Barge aft part	
<b>7</b>	<b>Hull outfitting</b>	<b>243</b>
7.1	Rudder and steering gear	
<b>8</b>	<b>Construction and testing</b>	<b>243</b>
8.1	Test of the disconnection procedure of removable connection	

# CHAPTER 15

## SUPPLY VESSELS

### Section 1 General

<b>1</b>	<b>General</b>	<b>247</b>
1.1	Application	
1.2	Summary table	

### Section 2 Hull and Stability

<b>1</b>	<b>General</b>	<b>248</b>
1.1	Definitions	
<b>2</b>	<b>General arrangement design</b>	<b>249</b>
2.1	Compartment arrangement for all ships	
2.2	Compartment arrangement for ships with additional service feature "oil product"	
2.3	Compartment arrangement for ships with additional service feature "chemical product"	
2.4	Compartment arrangement for ships with additional service feature "standby vessel "	
2.5	Access arrangement for all ships	
2.6	Access arrangement for ships with additional service feature "oil product"	
2.7	Access arrangement for ships with additional service feature "chemical product"	
2.8	Access arrangement for ships with additional service feature "standby vessel"	
2.9	Additional arrangements and equipment for supply vessels with additional service feature "rescue"	
2.10	Additional requirements for supply vessels with additional service feature "anchor handling" and "anchor handling stab"	
<b>3</b>	<b>Stability</b>	<b>254</b>
3.1	General	
3.2	Intact stability for all ships	
3.3	Intact stability for ships with additional service feature "oil product"	
3.4	Intact stability for ships with additional service feature "anchor handling stab"	
<b>4</b>	<b>Structure design principles</b>	<b>256</b>
4.1	General	
4.2	Side structure exposed to bumping	
4.3	Deck structure	
4.4	Structure of cement tanks and mud compartments	
<b>5</b>	<b>Design loads</b>	<b>257</b>
5.1	Dry uniform cargoes	
<b>6</b>	<b>Hull scantlings</b>	<b>257</b>
6.1	Plating	
6.2	Ordinary stiffeners	
6.3	Primary supporting members	



<b>7</b>	<b>Other structure</b>	<b>257</b>
	7.1 Aft part	
	7.2 Superstructures and deckhouses	
	7.3 Arrangement for hull and superstructure openings	
<b>8</b>	<b>Hull outfitting</b>	<b>259</b>
	8.1 Rudders	
	8.2 Bulwarks	
	8.3 Strength of rollers and their supporting structures for ships with additional service feature "anchor handling" and "anchor handling stab"	
	8.4 Equipment	
	8.5 Arrangement of winches used for anchor handling operations for ships with additional service feature "anchor handling"	
	8.6 Arrangement of winches used for anchor handling operations for ships with additional service feature "anchor handling stab"	

### **Section 3 Machinery and Cargo Systems**

<b>1</b>	<b>General</b>	<b>261</b>
	1.1 Application	
	1.2 Documents to be submitted	
<b>2</b>	<b>Machinery systems</b>	<b>261</b>
	2.1 Bilge system	
	2.2 Other piping systems not intended for cargo	
	2.3 Cargo heating systems	
	2.4 Exhaust pipes	
	2.5 Steering gear	
<b>3</b>	<b>Cargo systems - Requirements applicable to oil and chemical products</b>	<b>262</b>
	3.1 Cargo segregation	
	3.2 Materials	
	3.3 Installation of independent portable tanks	
<b>4</b>	<b>Cargo systems of ships having the service feature "oil product"</b>	<b>262</b>
	4.1 Cargo pumping system, piping system and pump rooms	
	4.2 Cargo tanks and cargo storage vessels	
	4.3 Prevention of pollution	
<b>5</b>	<b>Cargo systems of ships having the service feature "chemical product"</b>	<b>263</b>
	5.1 General	
	5.2 Cargo pumping and piping systems	
	5.3 Cargo tanks	
	5.4 Prevention of pollution	
	5.5 Personnel protection	
<b>6</b>	<b>Requirements for windlass</b>	<b>265</b>
	6.1 Assumptions for the calculation of the continuous duty pull	
	6.2 Calculation of the continuous duty pull	



<b>SECTION 1</b>	<b>GENERAL</b>
<b>SECTION 2</b>	<b>SHIP SURVIVAL CAPABILITY AND LOCATION OF CARGO TANKS</b>
<b>SECTION 3</b>	<b>SHIP ARRANGEMENT</b>
<b>SECTION 4</b>	<b>CARGO CONTAINMENT</b>
<b>SECTION 5</b>	<b>CARGO TRANSFER</b>
<b>SECTION 6</b>	<b>MATERIALS FOR CONSTRUCTION</b>
<b>SECTION 7</b>	<b>CARGO TEMPERATURE CONTROL</b>
<b>SECTION 8</b>	<b>CARGO TANK VENTING AND GAS-FREEING ARRANGEMENTS</b>
<b>SECTION 9</b>	<b>ENVIRONMENTAL CONTROL</b>
<b>SECTION 10</b>	<b>ELECTRICAL INSTALLATIONS</b>
<b>SECTION 11</b>	<b>FIRE PROTECTION AND FIRE EXTINCTION</b>
<b>SECTION 12</b>	<b>MECHANICAL VENTILATION IN THE CARGO AREA</b>
<b>SECTION 13</b>	<b>INSTRUMENTATION</b>
<b>SECTION 14</b>	<b>PROTECTION OF PERSONNEL</b>
<b>SECTION 15</b>	<b>SPECIAL REQUIREMENTS</b>
<b>SECTION 16</b>	<b>OPERATIONAL REQUIREMENTS AND ADDITIONAL MEASURES FOR THE PROTECTION OF THE MARINE ENVIRONMENT</b>
<b>SECTION 17</b>	<b>SUMMARY OF MINIMUM REQUIREMENTS</b>
<b>SECTION 18</b>	<b>LIST OF CHEMICALS TO WHICH THIS CHAPTER DOES NOT APPLY</b>
<b>SECTION 19</b>	<b>INDEX OF PRODUCTS CARRIED IN BULK</b>
<b>SECTION 20</b>	<b>TRANSPORT OF LIQUID CHEMICAL WASTES</b>
<b>SECTION 21</b>	<b>CRITERIA FOR ASSIGNING CARRIAGE REQUIREMENTS FOR PRODUCTS SUBJECT TO THE IBC CODE</b>



# SECTION 1 GENERAL

## 1 Scope

### 1.1 Application

#### 1.1.1 Chemical tankers (1/8/2022)

The **chemical tanker** service notation, in accordance with Pt A, Ch 1, Sec 2, [4.5.4], may be granted to ships which are intended for the carriage of products listed in the table in Chapter 17 of the IBC Code. These ships are to comply with the requirements of the latest version of the International Code for the Construction and Equipment of Ships Carrying Dangerous Chemicals in Bulk (IBC Code), as amended. In these Rules reference to this Code and its amendments is made by the wording "IBC Code".

The **chemical tanker** service notation may be completed by the additional feature **IMO 1**, **IMO 2** or **IMO 3** when the ship complies with the requirements for the assignment of type 1, type 2 or type 3, respectively, according to Chapter 2 of the IBC Code.

Ships assigned with the service notation **chemical tanker** and the additional service feature **IMO 2** or **IMO 3** may be completed by the additional service feature **IMO 1 (tank name)**, when the ship complies with the requirements for the assignment of type 1, according to Chapter 2 paragraphs 2.5, 2.7, 2.8 and 2.9 of the IBC Code, and the location of the named tank complies with the requirements for a type 1 ship in paragraph 2.6 of the IBC Code.

Ships assigned with the service notation **chemical tanker** and the additional service feature **IMO 3** may be completed by the additional service feature **IMO 2 (tank name)**, when the ship complies with the requirements for the assignment of type 2, according to Chapter 2 paragraphs 2.5, 2.7, 2.8 and 2.9 of the IBC Code, and the location of the named tank complies with the requirements for a type 2 ship in paragraph 2.6 of the IBC Code.

#### 1.1.2 IBC Code requirements and the Society's rules

- a) For ships with the service notation **chemical tanker**, the IBC Code requirements are to be considered as rule requirements, with the exception indicated in [1.1.3].
- b) The requirements of this Chapter supplement those of the IBC Code. These requirements include additional mandatory class requirements, as well as the Society's interpretations of the IBC Code, which are also to be considered mandatory for class.
- c) In general, this Chapter applies to cargo containment and handling systems and to the interfaces between

these systems and the other parts of the ship, which are to comply with the applicable Sections of the hull and machinery Rules.

#### 1.1.3 IBC Code requirements not within the scope of classification (1/1/2007)

The following requirements of the IBC Code are not within the scope of classification:

- Chapter 1, Section 1.4 - Equivalents
- Chapter 1, Section 1.5 - Surveys and certification
- Chapter 2, Section 2.4 - Condition of loading
- Chapter 2, Section 2.5 - Damage assumption
- Chapter 2, Section 2.7 - Flooding assumption
- Chapter 2, Section 2.8 - Standard of damage
- Chapter 2, Section 2.9 - Survival requirements
- Chapter 11 - Fire protection and fire extinction
- Chapter 14 - Personnel protection
- Chapter 16 - Operating requirements
- Chapter 16A - Additional measures for the protection of the marine environment.

These requirements are applied by the Society when acting on behalf of the flag Administration, within the scope of delegation (see [1.1.8]).

#### 1.1.4 Carriage of products not listed in the Code

The requirements of the IBC Code and the additional requirements of this Chapter are also applicable to new products, which may be considered to come within the scope of these Rules, but are not at present listed in either of the tables in Chapter 17 or Chapter 18 of the IBC Code.

#### 1.1.5 Particularly hazardous products

For the carriage in bulk of products which are not listed in either of the tables in Chapter 17 or Chapter 18 of the IBC Code, presenting more severe hazards than those covered by the IBC Code, the Society reserves the right to establish requirements and/or conditions additional to those contained in these Rules.

#### 1.1.6 Correspondence of the IBC Code with Part E Chapter 8 of the Rules

All the requirements of this Chapter are cross referenced to the applicable Chapters, Sections or paragraphs of the IBC Code, as appropriate.

#### 1.1.7 Equivalence

As far as the requirements for class are concerned, the following wording in the IBC Code is to be given the meanings indicated in Tab 1.

**Table 1**

IBC Code wording	Meaning for Classification only
Administration	Society
IGC Code or Gas Code	Part E Chapter 9 of the Rules
Recognised Standard	Rules
should be	is to be or are to be (as appropriate)

**1.1.8 Certificate of Fitness**

- a) The responsibility for interpretation of the IBC Code requirements for the purpose of issuing an International Certificate of Fitness for the Carriage of Dangerous Chemicals in Bulk lies with the Administration of the state whose flag the ship is entitled to fly.
- b) Whenever the Society is authorised by an Administration to issue on its behalf the "Certificate of Fitness for the Carriage of Dangerous Chemicals in Bulk", or where the Society is authorised to carry out investigations and surveys on behalf of an Administration on the basis of which the "Certificate of Fitness for the Carriage of Dangerous Chemicals in Bulk" will be issued by the Administration, or where the Society is requested to certify compliance with the IBC Code, the full compliance

with the requirements of the IBC Code, including the operative requirements mentioned in [1.1.3], is to be granted by the Society.

**2 Additional requirements****2.1 Emergency towing arrangement**

**2.1.1** Emergency towing arrangements are to be fitted on chemical tankers of 20.000  $d_{wt}$  and above in accordance with Pt B, Ch 10, Sec 4, [4].

**2.2 Steering gear**

**2.2.1** Additional requirements for steering gear of chemical tankers of 10000  $d_{wt}$  and above are given in Ch 7, Sec 4, [7].

**3 Documentation to be submitted****3.1**

**3.1.1** Tab 2 lists the plans, information, analysis, etc. which are to be submitted in addition to the information required in the other Parts of the Rules for the parts of the ship not affected by the cargo, as applicable.

**Table 2 : Documents to be submitted**

No.	A/I	Document
1	I	List of products to be carried, including maximum vapour pressure, maximum liquid cargo temperature and other important design conditions
2	I	General arrangement plan, showing location of cargo tanks and fuel oil, ballast and other tanks
3	A	Gas-dangerous zones plan
4	A	Location of void spaces and accesses to dangerous zones
5	A	Ventilation duct arrangement in gas-dangerous spaces and adjacent zones
6	A	Details of hull structure in way of cargo tanks, including support arrangement for tanks, saddles, anti-floating and anti-lifting devices, deck sealing arrangements, independent cargo tanks, etc.
7	A	Hull stress analysis
8	A	Hull ship-motion analysis, where a direct analysis is preferred to the methods indicated in Section 4
9	A	Intact and damage stability calculations
10	A	Scantlings, material and arrangement of the cargo containment system
11	A	Details of steel cladding or lining
12	A	Plans and calculations of safety relief valves
13	A	Details of cargo handling, including arrangements and details of piping and fittings
14	A	Details of cargo pumps
15	A	Details of process pressure vessels and relative valving arrangement
16	A	Bilge and ballast system in cargo area
17	A	Gas freeing system in cargo tanks including inert gas system
18	A	Ventilation system in cargo area
19	A	Details of electrical equipment installed in cargo area, including the list of certified safe equipment and apparatus and electrical bonding of cargo tanks and piping

No.	A/I	Document
20	A	Schematic electrical wiring diagram
21	A	Gas detection system
22	A	Cargo tank instrumentation
23	A	Details of fire-extinguishing appliances and systems in cargo area
24	I	Loading and unloading operation description, including cargo tank filling limits, where applicable

**Note 1:** A = to be submitted for approval in four copies  
I = to be submitted for information in duplicate

## SECTION 2

# SHIP SURVIVAL CAPABILITY AND LOCATION OF CARGO TANKS

### 1 Freeboard and intact stability

#### 1.1 Intact stability

##### 1.1.1 General

IBC CODE REFERENCE : Ch 2, 2.2

The stability of the ship for the loading conditions in Pt B, Ch 3, App 2, [1.2.7] is to be in compliance with the requirements in Pt B, Ch 3, Sec 2.

##### 1.1.2 Information to be supplied

IBC CODE REFERENCE : Ch 2, 2.5

The Master of the ship is to be supplied with a Loading Manual as specified in Pt B, Ch 11, Sec 2, [3] and a Trim and Stability booklet as specified in Pt B, Ch 3, App 2.

### 2 Location of cargo tanks

#### 2.1 Minimum distance of cargo tanks from shell

##### 2.1.1 Exceptions

IBC CODE REFERENCE : Ch 2, 2.6.1

Any cargo tank, irrespective of its location, may be used for collecting contaminated cargo pump room bilge water or

tank washings, as an exception to the requirements in IBC Code 2.6.1.1.

#### 2.2 Suction wells

##### 2.2.1

IBC CODE REFERENCE : Ch 2, 2.6.2

In general, the area of suction wells is not to be greater than that required to accommodate cargo pumps, suction pipes, valves, heating coils etc., and to ensure efficient flow and the necessary access for cleaning and maintenance.

### 3 Flooding assumptions

#### 3.1 Tunnels, ducts and pipes in the damaged zone

##### 3.1.1 Strength of internal structures

Tunnels, ducts, pipes, doors, bulkheads and decks which might form watertight boundaries of intact spaces in the case of assumed conventional damage are to have minimum strength adequate to withstand the pressure height corresponding to the deepest equilibrium waterline in damaged conditions.



## SECTION 3

## SHIP ARRANGEMENT

### 1 Cargo segregation

#### 1.1 Segregation of cargoes mutually reacting

##### 1.1.1 Common edges

IBC CODE REFERENCE : Ch 3, 3.1.2

The common edge in a cruciform joint, either vertically or horizontally, may be considered a "double barrier" for the purpose of segregation:

- between mutually reactive products (see Fig 1)
- between water reactive products and water (see Fig 1).

##### 1.1.2 Chain lockers

IBC CODE REFERENCE : Ch 3, 3.1.2

The chain locker is to be arranged outside the cargo area.

#### 1.2 Cargo piping arrangement

##### 1.2.1 Bow or stern loading arrangement

IBC CODE REFERENCE : Ch 3, 3.1.3

The requirement in IBC Code 3.1.3 is considered to be satisfied if the requirements in IBC Code 3.7, relevant to bow or stern loading and unloading arrangements, are complied with.

### 2 Accommodation, service and machinery spaces and control stations

#### 2.1 Air intakes and other openings to accommodation spaces

##### 2.1.1

IBC CODE REFERENCE : Ch 3, 3.2.2

The requirements relevant to air intakes in IBC Code 3.2.2 are also intended to be applicable to air outlets. This interpretation also applies to the requirements in IBC Code 3.2.3, 3.7.4, 8.3, 15.12.1.3 and 19.3.8.

#### 2.2 Windows, sidescuttles and doors

##### 2.2.1 General requirements

IBC CODE REFERENCE : Ch 3, 3.2.3

- a) Access facing the cargo area or other prohibited zones is to be restricted to stores for cargo-related and safety equipment, cargo control stations and emergency shower spaces.
- b) Entrances and openings to service spaces located forward of the cargo area may not face such area. How-

ever, for small ships alternative arrangements may be specially considered by the Society.

- c) The bolt spacing for bolted plates mentioned in the paragraph in the reference is to be such as to guarantee a suitable gas-tightness.

#### 2.2.2 Ships fitted with deckhouses originating from main deck

IBC CODE REFERENCE : Ch 3, 3.2.3

On all chemical tankers, regardless of the type of products to be carried, where a deckhouse is substituted for a superstructure and liquid products could flow along the sides of the house, the house front is to be continued to the sides of the ship in the form of a sill, or a permanent spillage barrier is to be arranged as described in Regulation II-2/56.6 of SOLAS 74(83).

### 3 Cargo pump rooms

#### 3.1 General requirement

##### 3.1.1 Means of escape

IBC CODE REFERENCE : Ch 3, 3.3.1

In general, a cargo pump room is to be provided with one set of access/escape ladders. Where it is envisaged that personnel are normally employed in a pump room or the pump room is unusually large, an additional means of escape may be required.

##### 3.1.2 Segregation

IBC CODE REFERENCE : Ch 3, 3.3.1

Cargo pump rooms and pump rooms may not give direct access to other ship spaces and are to be separated from adjacent spaces by means of gas-tight bulkheads and/or decks.

#### 3.2 Machinery driven by shafting passing through pump room bulkheads

##### 3.2.1

IBC CODE REFERENCE : Ch 3, 3.3.7

- a) Bulkhead or deck penetrations of cargo pump rooms, or of pump rooms intended for runs of shafts driving pumps and/or fans, are to be provided with gas-tight sealing devices to the satisfaction of the Society.
- b) Lubrication or other means of ensuring permanence of gas-tightness of the above-mentioned sealing devices is to be arranged in such a way that it can be checked from outside the cargo pump room.

Figure 1 : Segregation of mutually hazardous reactive cargoes

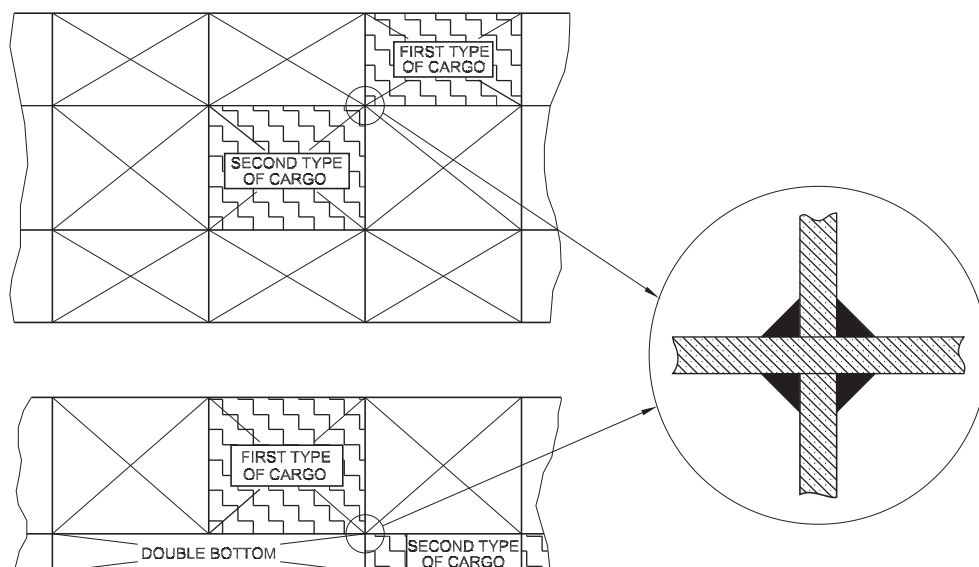

## 4 Fuel tanks in cargo area

### 4.1 Definition

#### 4.1.1 (1/7/2017)

Cargo tank block is the part of the ship as indicated in Fig 2 extending from the aft bulkhead of the aftmost cargo or slop tank to the forward bulkhead of the forward most cargo or slop tank, extending to the full depth and beam of the ship, but not including the area above the deck of the cargo or slop tank.

### 4.2 Location of fuel tanks in cargo area

#### 4.2.1 (1/7/2019)

- These requirements apply to chemical tankers carrying toxic (see Note 1) liquid cargoes.
- Fuel tanks located with a common boundary to cargo or slop tanks shall not be situated within nor extend partly into the cargo tank block. Such tanks may, however, be situated aft and/or forward of the cargo tank block.
- They may be accepted when located as independent tanks on open deck in the cargo area subject to spill and fire safety considerations.
- The arrangement of independent fuel tanks and associated fuel piping systems, including the pumps, can be as for fuel tanks and associated fuel piping systems located in the machinery spaces. For electrical equipment,

requirements to hazardous area classification must however be met.

Note 1: toxic liquid cargoes include those for which toxic vapour detection is specified in column "k" of the table of chapter 17 of the IBC Code.

## 5 Access arrangement

### 5.1 Access to compartments in the cargo area

#### 5.1.1 Access to fuel oil tanks

IBC CODE REFERENCE : Ch 3, 3.4.1

The requirements in IBC Code 3.4.1 apply to fuel oil tanks adjacent to cargo tanks even if such fuel oil tanks are not included in the "cargo area" as defined in IBC Code 1.3.5.

#### 5.1.2 Accesses and escapes from double bottom tanks and similar spaces

IBC CODE REFERENCE : Ch 3, 3.4.1

To cater for restrictions in the movement of personnel and to limit the time needed for a possible emergency escape, two separate means of access are generally to be fitted in double bottom tanks and similar spaces where obstructions impede movement. The two accesses are to be as widely separated as practicable. Only one access may be approved in special circumstances if, it being understood that the escapes have the required dimensions, the ability to readily traverse the space and to remove an injured person can be proved to the satisfaction of the Society.

Figure 2 (1/7/2017)

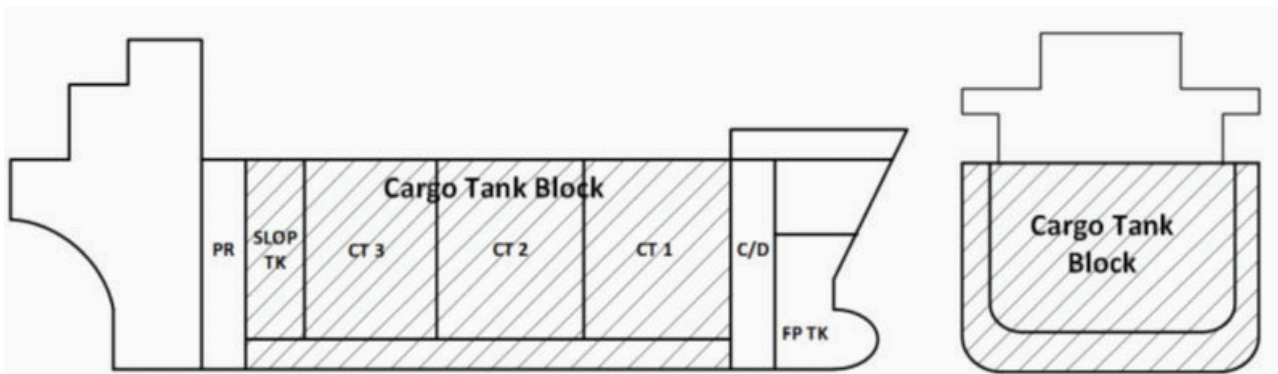

**5.1.3 Access through horizontal openings**

IBC CODE REFERENCE : Ch 3, 3.4.2

The shape of the minimum acceptable clear opening of 600 mm by 600 mm is indicated in Fig 3.

**Figure 3 : Shape of minimum acceptable clear opening of 600 mm by 600 mm**

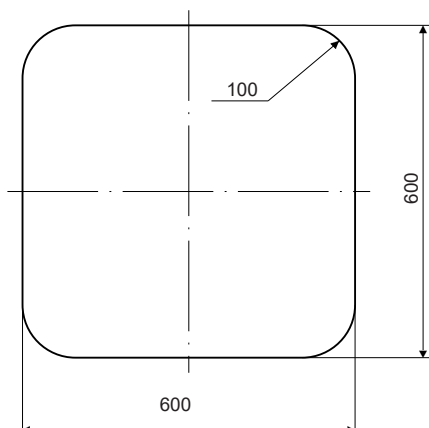

**5.1.4 Access through vertical openings**

IBC CODE REFERENCE : Ch 3, 3.4.3

For pressure cargo tanks only, access openings may be circular openings having a diameter not less than 600 mm.

The minimum size of vertical oval openings is defined in Fig 4.

**Figure 4 : Minimum size of vertical oval openings**

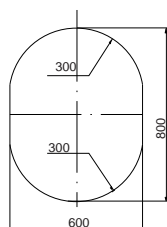

**5.2 Access to the bow**

**5.2.1 (1/7/2008)**

This item [5.2] applies to ships subject to the International Load Line Convention 1966, as amended.

**5.2.2 (1/7/2006)**

Chemical tankers are to be provided either with a gangway between the superstructure or deckhouse aft and the fore-castle, or with equivalent arrangements in accordance with the International Load Line Convention 1966, as amended.

**5.2.3 (1/7/2006)**

Chemical tankers are to be provided with the means to enable the crew to gain safe access to the bow even in severe weather conditions. Such means are to be accepted by the Society.

Note 1: The Society considers means in compliance with the Guidelines adopted by the Maritime Safety Committee of IMO with Resolution MSC.62(67) on 5/12/1996 as being acceptable.

**6 Bilge and ballast arrangements**

**6.1 Ballast segregation**

**6.1.1 Eductors**

IBC CODE REFERENCE : Ch 3, 3.5.1

An eductor situated in the cargo area using water power from pumps in the machinery spaces may be accepted as a means to discharge permanent ballast from tanks and/or double bottoms adjacent to cargo tanks, provided the supply line is above deck level and a non-return valve and removable spool piece are fitted in the supply line outside the machinery space (see Fig 5).

**Figure 5 : Discharge arrangement**

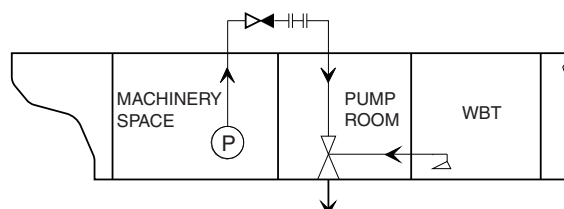

## 6.2 Ballast filling arrangement

### 6.2.1 Clarification

IBC CODE REFERENCE : Ch 3, 3.5.2

The filling of cargo tanks with ballast may be performed at deck level by means of pumps serving permanent ballast tanks, as specified in IBC Code 3.5.2, provided that a removable spool piece or flexible hose plus a shut-off valve are fitted on the inlet to the cargo tank. The shut-off valve is in addition to the required non-return valve. Consideration is to be given to the arrangement of the in-tank piping and the possible creation of static electricity (see Fig 5).

## 6.3 Bilge

### 6.3.1 Arrangement

IBC CODE REFERENCE : Ch 3, 3.5.3

The relaxation relevant to the bilge system for spaces which are separated from cargo tanks by a double bulkhead is to be understood as limited to spaces not enclosing piping which may contain cargo.

### 6.3.2 Use of cargo pumps as bilge pumps

IBC CODE REFERENCE : Ch 3, 3.5.3

- a) Cargo pumps may also be used as bilge pumps provided they are connected to the bilge piping through a shut-off valve and a non-return valve arranged in series.
- b) In the case of carriage of corrosive liquids, one of the cargo pumps, as specified in IBC Code 3.5.3, may be used for bilge service provided it is connected to the

bilge piping through two shut-off valves plus a non-return valve arranged in series.

- c) In cargo pump rooms of ships carrying toxic or corrosive products, suitable means for conveying spills from cargo pumps and valves to collecting trays are to be fitted. Trays may also consist of part of the pump room bottom, suitably bounded and protected against the corrosive action of products. Spills may be disposed of by means of suitable pumps or eductors. In the case of carriage of mutually incompatible products, the above-mentioned means for collecting and disposing of spills are to be different and separated from each other.

## 7 Bow or stern loading and unloading arrangements

### 7.1 Coamings

#### 7.1.1

IBC CODE REFERENCE : Ch 3, 3.7.7

In general, the height of the coaming is to be not less than 150 mm. In any case, it is to be not less than 50 mm above the upper edge of the sheerstrake.

## 8 Hull outfitting

### 8.1 Equipment

#### 8.1.1 Emergency towing arrangements

The specific requirements in Pt B, Ch 10, Sec 4, [4] for ships with the service notation **chemical tanker** and not less than 20000 t deadweight are to be complied with.

## SECTION 4

## CARGO CONTAINMENT

### Symbols

$k$  : Material factor for steel, defined in Pt B, Ch 4, Sec 1, [2.3]

## 1 Structure design principles

### 1.1 Materials

#### 1.1.1 Steels for hull structure

IBC CODE REFERENCE: Ch 4

In addition to the requirements of Pt B, Ch 4, Sec 1, [2], materials of cargo tanks are to be considered by the Society on a case-by-case basis for all the products intended to be carried.

#### 1.1.2 Rolled plates

IBC CODE REFERENCE: Ch 4

Rolled plates of non-alloyed steel or stainless steel may be used for the construction of tanks. Mechanical characteristics, approval procedure and testing of these plates are to comply with the applicable requirements in Part D.

#### 1.1.3 Young's modulus for stainless steels

IBC CODE REFERENCE: Ch 4

For stainless steels, Young's modulus is to be taken equal to 193000 N/mm<sup>2</sup>.

#### 1.1.4 Rubber and synthetic material liner

IBC CODE REFERENCE: Ch 4

The suitability of rubber or synthetic material lining is to be considered by the Society on a case-by-case basis.

### 1.2 Hull structure

#### 1.2.1 Framing arrangement

IBC CODE REFERENCE: Ch 4

In general, within the cargo tank region of chemical tankers of more than 90 m in length, the bottom, the inner bottom and the deck are to be longitudinally framed.

Different framing arrangements are considered by the Society on a case-by-case basis, provided that they are supported by direct calculations.

### 1.3 Bulkhead structure

#### 1.3.1 Corrugated bulkhead connections

IBC CODE REFERENCE: Ch 4

For ships with  $L < 120$  m, vertically corrugated transverse or longitudinal bulkheads may be connected to the double bottom and deck plating (see Fig 1).

For ships with  $L \geq 120$  m, a lower and an upper stool are generally to be fitted (see Fig 2). Different arrangements may be considered by the Society on a case-by-case basis, provided that they are supported by direct calculations carried out according to Pt B, Ch 7, Sec 3. These calculations are to investigate, in particular, the zones of connection of the bulkhead with bottom and deck plating and are to be submitted to the Society for review.

**Figure 1 : Corrugated bulkhead connections without stool**

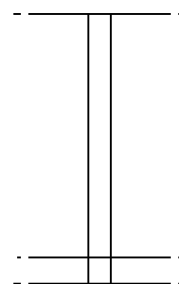

**Figure 2 : Corrugated bulkhead connections with lower and upper stools**

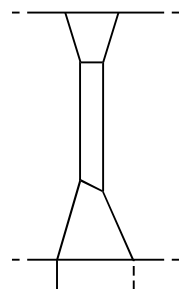

## 2 Hull girder loads

### 2.1 Still water loads

#### 2.1.1 Loading conditions

IBC CODE REFERENCE: Ch 4

In addition to the requirements in Pt B, Ch 5, Sec 2, [2.1], still water loads are to be calculated for the following loading conditions:

- homogeneous loading conditions (excluding tanks intended exclusively for segregated ballast tanks) at maximum draught
- partial loading conditions
- high density cargo, heated cargo and segregated cargo loading conditions

- any specified non-homogeneous loading condition
- light and heavy ballast conditions
- mid-voyage conditions related to tank cleaning or other operations where these differ significantly from the ballast conditions.

### 3 Scantlings of integral tanks

#### 3.1 Plating

##### 3.1.1 Minimum net thicknesses (1/7/2002)

IBC CODE REFERENCE: Ch 4

The net thickness of the strength deck and bulkhead plating within or bounding the longitudinal extension of the cargo area is to be not less than the values given in Tab 1.

**Table 1 : Minimum net thickness of the strength deck and bulkhead plating**

Plating	Minimum net thickness, in mm
Strength deck	$(5,5 + 0,02 L) k^{1/2}$ for $L < 200$ $(8 + 0,0085 L) k^{1/2}$ for $L \geq 200$
Tank bulkhead	$L^{1/3} k^{1/6} + 4,5 s$
Watertight bulkhead	$0,85 L^{1/3} k^{1/6} + 4,5 s$
Wash bulkhead	$0,8 + 0,013 L k^{1/2} + 4,5 s$
<b>Note 1:</b>	
s	: Length, in m, of the shorter side of the plate panel.

##### 3.1.2 Calculation of equivalent thickness for clad plates made of non-alloyed steel - stainless steel

IBC CODE REFERENCE: Ch 4

The clad plate thickness is to be not less than that obtained from the following formula:

$$t_p = t + t_s \left( 1 - \frac{E_i}{206000} \right)$$

where:

t : Thickness, in mm, of the clad plate, to be obtained from the applicable formulae in Pt B, Ch 7, Sec 1, as if it were made of homogeneous material with the following properties:

- elastic modulus, in N/mm<sup>2</sup>, to be taken equal to:

$$E = 206000$$

- material factor, to be obtained from the following formula:

$$k_0 = k \frac{E_i}{206000}$$

k : Material factor of the rolled stainless steel plate, defined in Pt B, Ch 4, Sec 1, [2.3]

$E_i$  : Elastic modulus, in N/mm<sup>2</sup>, of the rolled stainless steel plate

$t_s$  : Thickness, in mm, of the stainless steel cladding, to be taken not less than 2,0 mm.

Stainless steel cladding thicknesses other than those above are to be considered by the Society on a case-by-case basis.

#### 3.2 Ordinary stiffeners

##### 3.2.1 Minimum net thicknesses

IBC CODE REFERENCE: Ch 4

The net thickness of the web of ordinary stiffeners is to be not less than the value obtained, in mm, from the following formula:

$$t_{\text{MIN}} = 0,75 L^{1/3} k^{1/6} + 4,5 s$$

where s is the spacing, in m, of ordinary stiffeners.

#### 3.3 Primary supporting members

##### 3.3.1 Minimum net thicknesses

IBC CODE REFERENCE: Ch 4

The net thickness of plating which forms the webs of primary supporting members is to be not less than the value obtained, in mm, from the following formula:

$$t_{\text{MIN}} = 1,45 L^{1/3} k^{1/6}$$

##### 3.3.2 Loading conditions

IBC CODE REFERENCE: Ch 4

The still water and wave loads are to be calculated for the most severe of the loading conditions specified in [2.1.1], with a view to maximising the stresses in the longitudinal structure and primary supporting members.

##### 3.3.3 Cargo tank structure with hopper tank analysed through a three dimensional beam model

IBC CODE REFERENCE: Ch 4

Where the cargo tank structure with hopper tank is analysed through a three dimensional beam model, to be carried out in accordance with the requirements in Pt B, Ch 7, App 1, the net shear sectional area of floors within 0,1  $\ell$  from the floor ends (see Fig 3 for the definition of  $\ell$ ) is to be not less than the value obtained, in cm<sup>2</sup>, from the following formula:

$$A_{\text{Sh}} = 2 \frac{Q}{\gamma_R \gamma_m R_y}$$

where:

Q : Maximum shear force, in kN, obtained from the direct calculations

$\gamma_R$  : Resistance partial safety factor:

$$\gamma_R = 1,2$$

$\gamma_m$  : Material partial safety factor:

$$\gamma_m = 1,02$$

Figure 3 : End area of floors

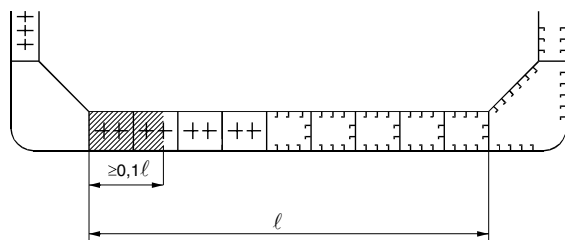

## 4 Scantlings of independent tank structures

### 4.1 Plating

#### 4.1.1 Strength checks

IBC CODE REFERENCE: Ch 4

In general, the net thickness of plating of independent tanks is to be not less than those obtained from the applicable formulae in Pt B, Ch 7, Sec 1, where the lateral pressures are to be calculated according to Part B, Chapter 5 and the hull girder stresses may be taken equal to zero.

Where, due to the tank arrangement, the above approximation is deemed unacceptable by the Society, the stresses in the tank due to the hull girder loads are to be taken into account. These stresses are, in general, to be calculated by means of direct calculations based on a finite element model of the hull and the tank with its supporting and keying system.

#### 4.1.2 Calculation of equivalent thickness of clad plates made of non-alloyed steel - stainless steel

IBC CODE REFERENCE: Ch 4

The requirements in [3.1.2] apply.

### 4.2 Ordinary stiffeners

#### 4.2.1 Strength check

IBC CODE REFERENCE: Ch 4

In general, the net scantlings of ordinary stiffeners of independent tanks are to be not less than those obtained from the applicable formulae in Pt B, Ch 7, Sec 2, where the lateral pressures are to be calculated according to Part B, Chapter 5 and the hull girder stresses may be taken equal to zero.

Where, due to the tank arrangement, the above approximation is deemed unacceptable by the Society, the stresses in the tank due to the hull girder loads are to be taken into account. These stresses are generally to be calculated as specified in [4.1.1].

### 4.3 Primary supporting members

#### 4.3.1 Loading conditions

IBC CODE REFERENCE: Ch 4

The still water and wave loads are to be calculated for the most severe of the loading conditions specified in [2.1.1],

with a view to maximising the stresses in the longitudinal structure and primary supporting members.

#### 4.3.2 Strength checks

IBC CODE REFERENCE: Ch 4

The net scantlings of primary supporting members of both the hull and independent tanks are to be obtained by means of direct calculations based on criteria to be agreed by the Society on a case-by-case basis.

## 5 Supports of independent tanks

### 5.1 Structural arrangement

#### 5.1.1 General

IBC CODE REFERENCE: Ch 4

The reaction forces in way of tank supports are to be transmitted as directly as possible to the hull primary supporting members, minimising stress concentrations.

Where the reaction forces are not in the plane of primary members, web plates and brackets are to be provided in order to transmit these loads by means of shear stresses.

#### 5.1.2 Openings

IBC CODE REFERENCE: Ch 4

In tank supports and hull structures in way, openings are to be reduced as much as possible and local strengthening may be necessary.

### 5.2 Calculation of reaction forces in way of tank supports

#### 5.2.1

IBC CODE REFERENCE: Ch 4

The reaction forces in way of tank supports are to be obtained from the structural analysis of the tank, considering the loads specified in Part B, Chapter 5.

If the tank supports are not able to react in tension, the final distribution of the reaction forces at the supports may not show any tensile forces.

### 5.3 Scantlings of independent tank supports and hull structures in way

#### 5.3.1 Scantlings

IBC CODE REFERENCE: Ch 4

The net scantlings of plating, ordinary stiffeners and primary supporting members of tank supports and hull structures in way are to be not less than those obtained by applying the criteria in Part B, Chapter 7, where the hull girder loads and the lateral pressure are to be calculated according to Part B, Chapter 5.

The values of reaction forces in way of tank supports to be considered for the scantlings of these structural elements are defined in [5.2].

## 6 Other structures

### 6.1 Machinery space

#### 6.1.1 Extension of the hull structures within the machinery space

IBC CODE REFERENCE: Ch 4

Longitudinal bulkheads carried through cofferdams are to continue within the machinery space and be used preferably as longitudinal bulkheads for liquid cargo tanks. This extension is to be compatible with the shape of the structures of the double bottom, of the deck and of platforms in the machinery space.

## 7 Protection of hull metallic structures

### 7.1 Aluminium coatings

#### 7.1.1 (1/1/2014)

IBC CODE REFERENCE: Ch 4

The use of aluminium coatings containing more than 10% aluminium by weight in the dry film is prohibited in the cargo tanks, cargo tank deck area, pump rooms, cofferdams or any other area where cargo vapour may accumulate.

### 7.2 Passivation treatment

#### 7.2.1

IBC CODE REFERENCE: Ch 4

For a stainless steel structure, a passivation treatment is to be made carefully on the whole area of the tanks for a new ship, and on the whole repaired area in the case of repairs. This applies in particular to the passivation treatment of the welds.

## 8 Construction and testing

### 8.1 Welding and weld connections

#### 8.1.1 Welding of bulkheads of cargo tanks of type 1 chemical carriers

IBC CODE REFERENCE: Ch 4

The boundaries of bulkheads of cargo tanks of type 1 chemical carriers are to be connected, for their whole length, to the hull structures by means of full penetration welding, as defined in the "Guide for welding".

#### 8.1.2 Welding of bulkheads of cargo tanks of type 2 chemical carriers (1/7/2003)

IBC CODE REFERENCE: Ch 4

The lower part of the boundaries of bulkheads of cargo tanks, i.e. the connection with the bottom (or double bot-

tom, if any) and the connection with the lower part of the sloping plates, of type 2 chemical carriers are to be connected, for their whole length, to the hull structures by means of full penetration welding, as defined in Pt B, Ch 12, Sec 1, [2.4.1].

The other part of the tank boundaries may be connected by means of fillet welding, as defined in Pt B, Ch 12, Sec 1, [2.4.1]. In addition, partial penetration welding, as defined in Pt B, Ch 12, Sec 1, [2.4.1], may be considered on the basis of the results of strength analyses.

However, any more stringent requirement defined for specific connection types in Pt B, Ch 12, Sec 1 and Pt B, Ch 12, Sec 2, as the case may be, is to be complied with.

#### 8.1.3 Welding of stiffeners made of non-alloyed steel to stainless steel plates

IBC CODE REFERENCE: Ch 4

In general, stiffeners made of non-alloyed steel may not be directly welded to thin stainless steel plates.

However, where the welding of stiffeners and hull components made of normal strength steel to stainless steel plates is deemed acceptable by the Society, such welding is to be performed using austenitic-ferritic electrodes with high-grade nickel and chromium, such as the electrode type with 24% Cr, 14% Ni and 3% Mo.

#### 8.1.4 Welding on clad plates

IBC CODE REFERENCE: Ch 4

Welds carried out on clad plates are to be considered by the Society on a case-by-case basis.

In particular, when fillet welding is carried out directly on the rolled plate, the ultrasonic inspection of the plating bond is to be performed on a strip bond 100 mm wide, centred on the plate perpendicular to the plating. This ultrasonic inspection is to be carried out in accordance with Pt D, Ch 2, Sec 1, [8.9].

### 8.2 Special structural details

#### 8.2.1

IBC CODE REFERENCE: Ch 4

The specific requirements in Pt B, Ch 12, Sec 2, [2.3] for ships with the service notation **chemical tanker** are to be complied with.

### 8.3 Testing

#### 8.3.1 Tank testing

IBC CODE REFERENCE: Ch 4

In addition to the requirements in Pt B, Ch 12, Sec 3, [2.2], the tank testing is to comply with Tab 2.

**Table 2 : Additional requirements for chemical carrier tank testing**

Structure to be tested	Testing requirements	Structural test pressure
Integral or independent tanks.	Structural testing of cargo tank boundaries from at least one side, as defined in Pt B, Ch 12, Sec 3, [2.2].	The greater of the following: <ul style="list-style-type: none"> <li>• 2,4 m head of water above the highest point of the tank,</li> <li>• setting pressure of the safety relief valves, where relevant.</li> </ul>



## SECTION 5

## CARGO TRANSFER

### 1 Piping scantlings

#### 1.1 Pipe wall thickness calculation

##### 1.1.1 Piping subjected to green seas

IBC CODE REFERENCE : Ch 5, 5.1.1

For piping subjected to green seas, the design pressure P, in bar, in the formula in paragraph 5.1.1 of the IBC Code is to be replaced by an equivalent pressure P' given by the following formula:

$$P' = \frac{1}{2} \left( P + \sqrt{P^2 + 0,006 R' K \frac{D_c}{D}} \right)$$

where:

$D_c$  : External diameter of the pipe taking into account the insulation (in mm), whose thickness is to be taken at least equal to:

40 mm if  $D \leq 50$  mm

80 mm if  $D \geq 150$  mm

Intermediate values are to be determined by interpolation.

$R'$  : Drag corresponding to the effect of green seas, in da N/m<sup>2</sup>, such as given in Tab 1 as a function of the location of the pipes and of their height H (in m) above the deepest loadline; intermediate values are to be determined by interpolation.

$K$  : permissible stress, in N/mm<sup>2</sup>

##### 1.1.2 Corrosion allowance

IBC CODE REFERENCE : Ch 5, 5.1.1

The coefficient c (added corrosion thickness) for the formula in paragraph 5.1.1 of the IBC Code is normally to be equal to at least 3 mm. The Society may accept a lesser value for pipes made of austenitic or austenitic-ferritic stainless steel,

pipes with internal lining or, if applicable, pipes with acceptable external protective lining or painting.

### 2 Piping fabrication and joining details

#### 2.1 Pipes not required to be joined by welding

##### 2.1.1

IBC CODE REFERENCE : Ch 5, 5.2.2

Cargo piping is to be welded except for necessary flanged connections to valves, expansion joints (as permitted in paragraph 5.2.2.1 of the IBC Code), spool pieces and similar fittings or where required for coating, lining, fabrication, inspection or maintenance.

##### 2.1.2 Flanged connections (1/7/2011)

IBC CODE REFERENCE: Ch 5, 5.3.1

Flange types A and B in Pt C, Ch 1, Sec 10, Fig 1 are acceptable in piping systems with design pressure  $p > 1,6$  MPa.

Flange types A, B, C1, C2 and C3 are acceptable in piping systems with design pressure  $p \leq 1,6$  MPa.

The type of flanges on open-ended cargo piping or cargo piping placed inside cargo tanks may be considered by the Society on a case-by-case basis.

#### 2.2 Expansion joints

##### 2.2.1

IBC CODE REFERENCE : Ch 5, 5.2.4

The use of bellows is not permitted for corrosive and polymerising products, except if provision is made to prevent stagnation of liquids.

Table 1

External diameter of pipe (1)	Aft of the quarter of the ship's length			Forward of the quarter of the ship's length		
	H≤8	H=13	H≥18	H≤8	H=13	H≥18
≤25	1500	250	150	2200	350	150
50	1400	250	150	2000	350	150
75	1100	250	150	1600	350	150
100	700	250	150	700	350	150
≥150	500	250	150	700	350	150

(1)  $D_c$  if the pipe is insulated, D otherwise.

## 2.3 Non-destructive testing of welding

### 2.3.1

IBC CODE REFERENCE : Ch 5, 5.2.5

- Butt welded pipes and accessories are to be radiographic at random and entirely checked by means of a dye-penetrant test or an equivalent method.
- radiographic examinations are to cover at least 10% of the connections and may be extended, at the request of the Surveyor depending on the results of the inspection.
- Relaxation of the above requirements may be considered by the Society on a case-by-case basis for pipes welded at workshops. However, this only applies to ships exclusively intended to carry cargoes with minor fire risk.

## 2.4 Certification, inspection and testing of piping system

### 2.4.1 (1/7/2011)

Pipes, valves, fittings and other components are to be tested according to Tab 2.

## 3 Piping arrangements

### 3.1 Arrangement of cargo piping

#### 3.1.1 Arrangement of cargo piping under deck

IBC CODE REFERENCE : Ch 5, 5.5.2

The intent of the provisions in paragraph 5.5.2 of the IBC Code is to preclude the hazard of cargo leaking past a shut-off valve gland into the space where the valve is located.

### 3.1.2 Arrangement of cargo piping on deck

IBC CODE REFERENCE : Ch 5, 5.5.2

Cargo piping on cargo tanks is to be extended down to the bottom of each tank.

### 3.1.3 Aluminised pipes

IBC CODE REFERENCE : Ch 5, 5.5

Aluminised pipes may be permitted in ballast tanks, in inerted cargo tanks and, provided the pipes are protected from accidental impact, in hazardous areas on open deck.

## 3.2 Removable piping systems

### 3.2.1

IBC CODE REFERENCE : Ch 5, 5.5

Pumps, piping and associated fittings are to constitute a permanently fitted system; in general, removable parts are not allowed, except for specific cases for which it can be proved, to the satisfaction of the Society, that no effective alternative solutions are available. In such circumstances, the safety measures deemed necessary will be considered by the Society on a case-by-case basis.

## 4 Cargo transfer control systems

### 4.1 General

#### 4.1.1

IBC CODE REFERENCE : Ch 5, 5.6.1

- One blank flange is to be provided in addition to the stop valve required in paragraph 5.6.1.2 of the IBC Code at each cargo hose connection.
- The requirements of paragraph 5.6.1 of the IBC Code are not intended to be additional to those for piping below deck in 5.5.2 and 5.5.3 of the IBC Code.

**Table 2 (1/7/2011)**

No.	Item	Tests for materials (1)		Inspections and tests for the products (1)		
		Tests required	Type of material certificate (2) (3)	During manufacturing (NDT)	After completion	Type of product certificate (2)
1	pipes, flanges and fittings	X	C (4)		X	C
2	valves	X	C (4)	X (5)	X	C
3	pumps	X	W		X	C
4	cargo tank P/V and high velocity valves	X	C	X	X	C

(1) X = test required.

(2) C = class certificate, W = works' certificate.

(3) W is requested for pipes of open-ended piping and piping within cargo tanks.

(4) W is accepted for  $d < 100$  mm

(5) if of welded construction

## 4.2 Control, monitoring and alarm devices and cargo control room

### 4.2.1

IBC CODE REFERENCE : Ch 5, 5.6

- a) The cargo pump control is to be fitted in a position which is readily accessible, even in the event that the cargo piping or hoses break. This position is to be clearly indicated.
- b) Where a cargo control room is fitted, the following controls, monitoring and alarms are to be connected to this room:
  - cargo pump control
  - control of loading/unloading valves
  - level gauges
  - temperature indicators
  - high level alarms
  - very high level alarms
  - high/low temperature alarms
  - high/low pressure alarms
  - fixed gas detecting system alarms.
- c) In general, high/low temperature alarms are also to be transduced to the navigating bridge.
- d) The cargo control room is to be located above the weather deck and may be considered as a dangerous space or a safe space, depending on its location and on the possible presence of a product or of its vapours. If it is considered a dangerous space, it is to be provided with a ventilation system capable of supplying at least 20 air changes per hour, it is not to be located in the accommodation area and only safe type electrical equipment is allowed.
- e) A cargo control room without cargo pump and valve control is defined as a "cargo control station".

## 5 Ship's cargo hoses

### 5.1 Compatibility

#### 5.1.1

IBC CODE REFERENCE : Ch 5, 5.7.1

The requirement of paragraph 5.7.1 of the IBC Code applies to cargo hoses carried on board the vessel and "compatibility with the cargo" means that:

- a) the cargo hose does not lose its mechanical strength or deteriorate unduly when in contact with the cargo, and
- b) the cargo hose material does not affect the cargo in a hazardous way.

Consideration is to be given to internal and external surfaces with respect to the above where hoses may be used as

an integral part of, or connected to, emergency cargo pumps and submerged in the cargo tank.

## 6 Bonding

### 6.1 Static electricity

#### 6.1.1 Acceptable resistance

IBC CODE REFERENCE : Ch 10, 10.3

To avoid the hazard of an incentive discharge due to the build-up of static electricity resulting from the flow of the liquid/gases/vapours, the resistance between any point on the surface of the cargo and slop tanks, piping systems and equipment, and the hull of the ship is not to be greater than  $10^6 \Omega$ .

#### 6.1.2 Bonding straps (1/1/2014)

IBC CODE REFERENCE : Ch 10, 10.3

Bonding straps are required for cargo and slop tanks, piping systems and equipment which are not permanently connected to the hull of the ship, for example:

- a) independent cargo tanks
- b) cargo tank piping systems which are electrically separated from the hull of the ship
- c) pipe connections arranged for the removal of the spool pieces.
- d) wafer-style valves with non-conductive (e.g. PTFE) gaskets or seals.

Where bonding straps are required, they are to be:

- clearly visible so that any shortcoming can be clearly detected
- designed and sited so that they are protected against mechanical damage and are not affected by high resistivity contamination, e.g. corrosive products or paint
- easy to install and replace.

## 7 Integrated cargo and ballast system

### 7.1 General

#### 7.1.1 (1/1/2004)

The requirements for integrated cargo and ballast systems are given in Ch 7, Sec 4, [3.5].

## SECTION 6

## MATERIALS FOR CONSTRUCTION

### 1 General

#### 1.1 Material and coating characteristics

##### 1.1.1 (1/1/2007)

IBC CODE REFERENCE : Ch 6, 6.1

- a) As a general requirement, the provisions under Part D of the Rules apply. Materials for tanks are, in any case, to have properties which are not lower than those of hull steels used according to Part D of the Rules; if of quality other than required, their use will be considered by the Society on a case-by-case basis.
- b) In the construction of cargo tanks intended to carry cargo and sea water ballast alternately, the utmost care is to be given to the selection of structural material (in general austenitic stainless steel) with particular attention to its resistance to different types of isolated corrosion:
- pitting
  - stress corrosion
  - interstice corrosion.

In addition, these structures are to be constructed with the same type of material to avoid galvanic corrosion, which would arise if dissimilar materials were present. In addition to the structures, the above is also intended to apply to the materials of systems, devices and apparatuses fitted in the tanks.

- c) Sea water ballast tank structures may be partly of stainless steel and partly of hull steel, provided suitable measures are taken against hull steel corrosion. The use of appropriate protective coatings is subject to the positive outcome of the previous checks and tests, to the satisfaction of the Society, which may also require surveys to be performed at shorter intervals than for normal surveys. In estimating the suitability of the protective system, the Society may also require that the cathodic area is drastically reduced (for example, by also suitably protecting stainless steel structures) for the purpose of avoiding extremely isolated corrosion in hull steel structures which could possibly turn out, for various reasons, not to be protected by coating.
- d) The use of aluminium coatings is prohibited in the cargo tanks, cargo tank deck area, pump rooms, cofferdams or any other area where cargo gas may accumulate.

## SECTION 7

## CARGO TEMPERATURE CONTROL

### 1 General

#### 1.1 Cargo heating and cooling systems

##### 1.1.1 Cargo temperature control systems

IBC CODE REFERENCE : Ch 7, 7.1.1

Wherever a particular temperature (higher or lower than the ambient temperature) is required to be maintained for the preservation of the cargo, one of the following systems is to be adopted:

- thermally insulated tanks capable of maintaining the temperature of the cargo within acceptable limits for the time of the voyage.
- a heating or cooling plant or refrigerating plant.
- a combination of a) and b) above.

##### 1.1.2 Additional requirements for heating and cooling plants (1/7/2007)

IBC CODE REFERENCE : Ch 7, 7.1.1

- Manifolds for the delivery and backflow of heating media are to be fitted on the weather deck; connections to cargo tanks for inlet and outlet are to be in way of the cargo tank top.
- Where the heat exchanger room is located in the accommodation area and considered as gas-safe, it is to be treated as a machinery space (not a category A machinery space) and provided with independent mechanical extraction ventilation as well as with scuppers discharging directly into the machinery space.
- The maximum temperature of steam and heating media within the cargo area is to be adjusted to take into account the temperature class of the cargoes.

##### 1.1.3 Reference temperature

IBC CODE REFERENCE : Ch 7, 7.1.1

Wherever the cargo temperature is maintained by a heating or refrigerating plant, unless otherwise indicated in the contract specification, the system is to be designed taking into account the reference temperatures indicated in Tab 1.

Table 1

Reference temperature (°C)		
	Heating system	Cooling system
Sea	0	32
Air	5	45

##### 1.1.4 Redundancy (1/7/2002)

IBC CODE REFERENCE : Ch 7, 7.1.1

Wherever the heating or cooling system is essential for the preservation of the cargo, the following components are to be duplicated:

- heating or cooling sources; in cargo heating systems, the Society may permit only one fired boiler capable of supplying the requested heating capacity to be installed, provided that sufficient spares for the burner and relevant auxiliaries are carried on board to enable any failure of the burner to be rectified by the ship's crew
- circulating pumps for cargo and heating or cooling media; if suitable for the use, cargo pumps may be employed for the circulation of the heating or cooling media
- refrigeration plant.

#### 1.2 Valves and other fittings

##### 1.2.1 Means for purging

IBC CODE REFERENCE : Ch 7, 7.1.3

Cargo heating or cooling systems are to be fitted with the necessary connections to purge, by inert gas or compressed air, the heating or cooling circuit of each cargo tank and to perform the pressure testing of the system.

#### 1.3 Cargo temperature measuring system

##### 1.3.1 Alarm

IBC CODE REFERENCE : Ch 7, 7.1.5

- An alarm system is required for those products which are carried in a heated condition (see paragraph 15.13.6 of the IBC Code) and for which, in column "o" of the tables in Chapter 17 of the IBC Code, reference is made to the requirements of paragraph 15.13 of the IBC Code.
- An alarm system is required for those products for which a carrying temperature not greater than certain limits is required by Chapter 15 of the IBC Code, such as elementary phosphorus and molten sulphur.
- An alarm connection to the navigating bridge and to the cargo control station, if fitted, is to be provided.

#### 1.4 Requirements for special products

##### 1.4.1 Products which may damage the cargo heating or cooling system

IBC CODE REFERENCE : Ch 7, 7.1.6

- The provisions of paragraph 7.1.6 of the IBC Code also apply to products which may damage the cargo heating or cooling system.

b) If the sampling equipment mentioned in paragraph 7.1.6.3 of the IBC Code consists of an observation tank for drains, this tank is generally to comply with the following requirements:

- it is to be located in the cargo area and provided with an air pipe with the end fitted with a flame screen, as per the Rules, and arranged at not less

than 3 m from openings of accommodation spaces and from sources of ignition

- it is to be fitted with a connection for discharge into the slop tanks with associated shut-off valves and sight glass and equipped with a sampling cock for backflowing medium analysis.

## SECTION 8

# CARGO TANK VENTING AND GAS-FREEING ARRANGEMENTS

### 1 Cargo tank venting

#### 1.1 Venting system drainage

##### 1.1.1 Large amounts of drainage

IBC CODE REFERENCE: Ch 8, 8.2.2

When large amounts of drainage from vent lines of the cargo tanks are envisaged, a hose connection to the drain line of the slop tank is to be provided.

### 2 Types of tank venting system

#### 2.1 Position of vent outlets

##### 2.1.1 Outlets from tanks intended for flammable and toxic products

IBC CODE REFERENCE: Ch 8, 8.3.3

Vent outlets of cargo tanks intended for the carriage of flammable or toxic products are to be arranged at a distance of

not less than 3 m from exhaust ducts and as far as possible from inlet ducts to pump rooms and cargo pump rooms.

### 3 Cargo tank gas-freeing

#### 3.1 Fans

##### 3.1.1

IBC CODE REFERENCE : Ch 8, 8.5

- a) The impellers and housing of either fixed or portable fans fitted in dangerous spaces are to be of non-sparking materials according to paragraph 12.1.8 of the IBC Code.
- b) In the case of fans installed in safe spaces, two non-return devices are to be fitted to avoid return of flammable and/or toxic cargo vapours to safe spaces when the ventilation system is shut down. These non-return devices are to operate in all normal conditions of ship trim and list.

## SECTION 9

## ENVIRONMENTAL CONTROL

### 1 General

#### 1.1 Control by inerting or padding

##### 1.1.1 Padding medium

IBC CODE REFERENCE : Ch 9, 9.1.3

The padding medium is to be compatible from the point of view of safety with the products to be carried, it is not to react with them and with air and it is to have chemical and physical properties deemed suitable by the Society. The system is to comply with the requirements for inert gas systems, as applicable.

#### 1.2 Control by drying

##### 1.2.1 Simultaneous carriage of incompatible products

IBC CODE REFERENCE : Ch 9, 9.1.4

In the case of simultaneous carriage of mutually incompatible products, dry gas supply piping systems to each cargo space are to be separate from each other.

#### 1.3 Special requirements for inert gas systems on chemical carriers

##### 1.3.1 Applicability (1/1/2007)

IBC CODE REFERENCE : Ch 9, 9.1

See Pt C, Ch 4, Sec 1, [8.2].

##### 1.3.2 Simultaneous carriage of incompatible products

IBC CODE REFERENCE : Ch 9, 9.1

The inert gas system is to comply with the requirements of paragraph 9.1.5.1 of the IBC Code, adapted, to the satisfaction of the Society, to the individual characteristics of the products to be carried. In the case of simultaneous carriage of mutually incompatible products, inert gas supply piping systems to each cargo space are to be separate from each other.

##### 1.3.3 Ships with no fixed inert gas system

IBC CODE REFERENCE : Ch 9, 9.1

Where no fixed installation for inert gas and/or dry gas production is provided for on board, the minimum quantity to be kept on board is established by the Master, based on the duration of the voyage, the anticipated daily temperature variations, gas leakage through cargo tank seals and experience of previous similar cases.

##### 1.3.4 Additional requirements

IBC CODE REFERENCE : Ch 9, 9.1

a) These requirements apply where an inert gas system based on oil fired inert gas generators is fitted on board

chemical tankers. Any proposal to use other sources of inert gas will be specially considered.

- b) In addition to the provisions in paragraph 9.1.5.1 of the IBC Code, the inert gas system is to comply with the requirements of IMO Resolution A 567(14). Any use of the word "Administration" in the Resolution is to be considered as meaning the Society.
- c) As an alternative to the water seal in the inert gas line on deck, an arrangement consisting of two shut-off valves in series with a venting valve in between may be accepted. The following conditions apply:
  - The operation of the valve is to be automatically executed. Signals for opening/closing are to be taken from the process directly, e.g. inert gas flow or differential pressure.
  - An alarm for faulty operation of the valves is to be provided, e.g. the operation status of "blower stop" and "supply valve(s) open" is an alarm condition.
- d) In addition to the requirements detailed in Resolution A567(14), the followings are to be complied with:
  - 1) Plans in diagrammatic form are to be submitted for appraisal and are to include the following:
    - details and arrangement of inert gas generating plant including all control monitoring devices
    - arrangement of piping system for distribution of the inert gas.
  - 2) In all cases, automatic combustion control, capable of producing suitable inert gas under all service conditions, is to be fitted.
  - 3) When two blowers are provided, the total required capacity of the inert gas system is preferably to be divided equally between the two and in no case is one blower to have a capacity less than 1/3 of the total required.
  - 4) Materials used in inert gas systems are to be suitable for their intended purpose in accordance with the Rules. In particular those parts of scrubbers, blowers, non-return devices, scrubber effluent and other drain pipes which may be subjected to corrosive action of the gases and/or liquids are to be either constructed of corrosion-resistant material or lined with rubber, glass fibre, epoxy resin or other equivalent coating material.
  - 5) A compartment in which any oil fired inert gas generator is situated is to be treated as a machinery space of category A in respect of fire protection.
  - 6) All of the equipment is to be installed on board and tried under working conditions to the satisfaction of the Surveyor.



## **1.4 Ventilation**

### **1.4.1**

IBC CODE REFERENCE : Ch 9, 9.1

When a cargo space ventilation system other than the venting system mentioned under paragraph 8.2 of the IBC Code

is required by these provisions, such system is to comply with the requirements established by the Society in each case.

## SECTION 10

## ELECTRICAL INSTALLATIONS

### 1 General

#### 1.1 Application

**1.1.1** The requirements in this Section apply, in addition to those contained in Part C, Chapter 2, to chemical tankers.

#### 1.2 Documentation to be submitted

**1.2.1** In addition to the documentation requested in Pt C, Ch 2, Sec 1, Tab 1, the following are to be submitted for approval:

- a) plan of hazardous areas
- b) document giving details of types of cables and safety characteristics of the equipment installed in hazardous areas
- c) diagrams of tank level indicator systems, high level alarm systems and overflow control systems where requested.

#### 1.3 System of supply

##### 1.3.1 (1/1/2007)

Earthed systems with hull return are not permitted, with the following exceptions to the satisfaction of the Society:

- a) impressed current cathodic protective systems
- b) limited and locally earthed systems, such as starting and ignition systems of internal combustion engines, provided that any possible resulting current does not flow directly through any hazardous area
- c) insulation level monitoring devices, provided that the circulation current of the device does not exceed 30 mA under the most unfavourable conditions
- d) intrinsically safe systems.

##### 1.3.2 (1/1/2007)

In insulated distribution systems, no current carrying part is to be earthed, other than:

- a) through an insulation level monitoring device
- b) through components used for the suppression of interference in radio circuits.

##### 1.3.3 (1/7/2009)

The additional limitations in the choice of the system of supply (type of distribution system) as per SOLAS Ch.II-1 Reg. 45.4.3 apply to ships subject to the SOLAS Convention.

#### 1.4 Electrical equipment

##### 1.4.1 (1/1/2007)

Electrical equipment, cables and wiring are not to be installed in hazardous locations unless they conform with standards not inferior to those given in IEC 60092-502 Standard.

#### 1.5 Earth detection

##### 1.5.1 (1/1/2007)

For both insulated and earthed distribution systems a device, or devices, are to be installed to continuously monitor the insulation to earth and to give an audible and visual alarm at a manned position in the event of an abnormally low level of insulation resistance and/or high level of leakage current.

The above is not applicable to systems mentioned in [1.3.1].

#### 1.6 Precautions against inlet of gases or vapours

##### 1.6.1 (1/1/2007)

Suitable arrangements are to be provided, to the satisfaction of the Society, so as to prevent the possibility of gases or vapours passing from a gas-dangerous space to another space through runs of cables or their conduits.

#### 1.7 Electrical equipment permitted in hazardous areas

##### 1.7.1 (1/1/2007)

Electrical equipment permitted in hazardous areas is that indicated in Pt C, Ch 2, Sec 3, [10.1.4], Pt C, Ch 2, Sec 3, [10.1.5] and Pt C, Ch 2, Sec 3, [10.1.6].

##### 1.7.2 (1/1/2007)

In addition to the requirements of [1.7.1], in Zone 1 and Zone 2 the installation of the following is permitted: hull fittings containing the terminals or shell plating penetrations for anodes or electrodes of an impressed current cathodic protection system, or transducers such as those for depth sounding or log systems, provided that such fittings are of gas-tight construction or housed within a gas-tight enclosure, and are not located adjacent to a cargo tank bulkhead. The design of such fittings or their enclosures and the means by which cables enter, as well as any testing to establish their gas-tightness, are to be to the satisfaction of the Society. The associated cables are to be protected by means of heavy gauge steel pipes with gas-tight joints.

**1.7.3 (1/1/2007)**

Enclosed or semi-enclosed spaces (not containing a source of hazard) having a direct opening, including those for ventilation, into any hazardous area, are to be designated as the same hazardous zone as the area in which the opening is located.

Electrical installations are to comply with the requirements for the space or area into which the opening leads.

Note 1: For openings, access and ventilation conditions affecting the extent of hazardous areas, see IEC Standard 60092-502.

**2 Special requirements for chemical tankers carrying flammable liquids having a flashpoint not exceeding 60°C****2.1 Hazardous area classification****2.1.1 (1/1/2007)**

For hazardous area classification see Ch 7, Sec 6, Tab 1.

**3 Special requirements for chemical tankers carrying flammable liquids having a flashpoint exceeding 60°C****3.1 Hazardous area classification****3.1.1 (1/1/2007)**

For hazardous area classification see Ch 7, Sec 5, Tab 2.

**3.2 Cargoes heated to a temperature above their flashpoint and cargoes heated to a temperature within 15°C of their flashpoint****3.2.1 (1/1/2007)**

The requirements under [2] apply.

## SECTION 11

## FIRE PROTECTION AND FIRE EXTINCTION

### 1 General

#### 1.1

##### 1.1.1 (1/1/2007)

This Section is void, as the provisions of Chapter 11 of the IBC Code are not mandatory for the class.

## SECTION 12

# MECHANICAL VENTILATION IN THE CARGO AREA

### 1 Spaces normally entered during cargo handling operations

#### 1.1 Miscellaneous requirements

##### 1.1.1 Ventilation system stopping

IBC CODE REFERENCE : Ch 12, 12.1

All required ventilation systems are to be capable of being stopped from a position located outside the served spaces and above the weather deck.

##### 1.1.2 Warning notices

IBC CODE REFERENCE : Ch 12, 12.1

In the proximity of entrances to all spaces served by the required mechanical ventilation systems, a clearly visible warning is to be posted requiring such spaces to be adequately ventilated prior to entering and relevant ventilation systems to be kept in operation all the time persons are present in the spaces themselves.

##### 1.1.3 Prevention of dangerous operation of electric motors

IBC CODE REFERENCE : Ch 12, 12.1

A suitable automatic device is to be fitted to prevent operation of electric motors driving cargo pumps and operation of other electrical equipment not of a certified safe type prior to ventilating the spaces where such motors or equipment are located, in order to render them gas-safe (to this end it is pointed out that IEC provisions require at least 10 changes of air based on the volume of the served space).

##### 1.1.4 Prevention of dangerous operation of cargo pumps

IBC CODE REFERENCE : Ch 12, 12.1

An automatic device is to be fitted capable of stopping motors driving cargo pumps and de-energising any other electrical equipment not of a certified safe type in the case of stoppage of ventilation in spaces where such motors and equipment are fitted. This provisions does not apply to motors and other electrical equipment fitted in the engine room.

##### 1.1.5 Alternative to extraction type ventilation systems

IBC CODE REFERENCE : Ch 12, 12.1

As an alternative to ventilation systems of the extraction type, required in [1.1.4], a ventilation system of the positive pressure type may be accepted:

- in the case of cargo pump rooms adjacent to cargo tanks or to other gas-dangerous spaces, or
- where, in adjacent gas-safe spaces, inclusive of spaces containing motors of cargo pumps, an adequate over-pressure is kept in relation to the cargo pump rooms themselves.

##### 1.1.6 Location of upper end of inlet ducts

IBC CODE REFERENCE : Ch 12, 12.1

With reference to the requirements of [1.1.5], the upper ends of inlet ducts are generally to be located at a distance not less than 3 m from ventilation ducts and air intakes serving the safe spaces mentioned therein.

##### 1.1.7 Minimum distance between inlet and extraction ducts

IBC CODE REFERENCE : Ch 12, 12.1

With reference to 12.1.6 of IBC Code, the upper ends of (inlet and extraction) ventilation ducts serving the same space are to be located at a distance from each other, measured horizontally, of not less than 3 m and, in general, at an adequate height above the weather deck, but in any case not less than 2,4 m. Greater heights are required in paragraph 15.17 of the IBC Code.

##### 1.1.8 Upper ends of ventilation ducts in ships carrying materials producing flammable vapours

IBC CODE REFERENCE : Ch 12, 12.1

For flammable products, or for products which may react with the ship's materials producing flammable vapours (such as strong acids), the upper ends of ventilation ducts are to be located at a distance of not less than 3 m from any source of ignition, as per the provisions of Sec 8, [2.1].

##### 1.1.9 Dampers

IBC CODE REFERENCE : Ch 12, 12.1

Ventilation ducts are to be provided with metallic dampers, fitted with the indication "open" and "closed". The dampers are to be located above the weather deck, in a readily accessible position.

##### 1.1.10 Location of electric motors of fans

IBC CODE REFERENCE : Ch 12,12.1

Electric motors driving fans are to be placed outside the served spaces and outside the ventilation ducts, in a suitable position with respect to the presence of flammable vapours.

##### 1.1.11 Penetration of motor shafts through bulkheads

IBC CODE REFERENCE : Ch 12, 12.1

Runs of shafts of electric motors driving fans through bulkheads or decks of gas-dangerous spaces or through ventilation ducts are to be provided with gas-tight seals, with oil glands or equivalent means, deemed suitable by the Society.

## 1.2 Additional requirements for non-sparking fans

### 1.2.1 Non-sparking fans

IBC CODE REFERENCE : Ch 12, 12.1

- a) A fan is considered as non-sparking if in both normal and abnormal conditions it is unlikely to produce sparks.
- b) The air gap between the impeller and the casing is to be not less than 0,1 of the shaft diameter in way of the impeller bearing and not less than 2 mm. It need not be more than 13 mm.

### 1.2.2 Materials for non-sparking fans

IBC CODE REFERENCE : Ch 12, 12.1

- a) The impeller and the housing in way of the impeller are to be made of alloys which are recognised as being spark proof by appropriate tests.
- b) Electrostatic charges in both the rotating body and the casing are to be prevented by the use of antistatic materials. Furthermore, the installation on board of the ventilation units is to be such as to ensure their safe bonding to the hull.
- c) Tests may not be required for fans having the following combinations:
  - impellers and/or housings of non-metallic material, due regard being paid to the elimination of static electricity
  - impellers and housings of non-ferrous materials
  - impellers of aluminium alloys or magnesium alloys and a ferrous (including austenitic stainless steel) housing on which a ring of suitable thickness of non-ferrous materials is fitted in way of the impeller
  - any combination of ferrous (including austenitic stainless steel) impellers and housings with not less than 13 mm design tip clearance.
- d) The following impellers and housings are considered as sparking and are not permitted:
  - impellers of an aluminium alloy or magnesium alloy and a ferrous housing, regardless of tip clearance
  - housing made of an aluminium alloy or a magnesium alloy and a ferrous impeller, regardless of tip clearance
  - any combination of ferrous impeller and housing with less than 13 mm design tip clearance.

### 1.2.3 Type test for non-sparking fans

IBC CODE REFERENCE : Ch 12, 12.1

Type tests on the finished product are to be carried out in accordance with the requirements of the Society or an equivalent national or international standard.

## 2 Pump rooms and other enclosed spaces normally entered

### 2.1 Clarification of general requirement

#### 2.1.1 (1/1/2001)

IBC CODE REFERENCE : Ch 12, 12.2

- a) The arrangements for the ventilation system of spaces to which paragraph 12.2 of the IBC Code applies are to comply, in general, with the provisions set out in the previous item 1, as applicable.
- b) The provisions of paragraph 12.2 of the IBC Code apply to all pump rooms, whether or not the control for pumps and valves which are installed in such rooms is fitted externally.
- c) The distance of the upper ends of extraction and inlet ducts from air intakes and other openings of spaces mentioned in paragraph 12.1.5 of the IBC Code is not to be less than 3 m measured horizontally. These systems are to be capable of being controlled from outside the spaces they serve and, in the proximity of the entrances to such spaces, the warning notice mentioned in [1.1.2] is to be posted.

## 3 Spaces not normally entered

### 3.1 Portable fans

#### 3.1.1 (1/1/2001)

IBC CODE REFERENCE : Ch 12, 12.3

- a) The type of portable fans and their connections to spaces to be ventilated are to be deemed suitable by the Society. Portable fans driven by electric or internal combustion motors are not acceptable.
- b) The arrangements for the ventilation of these spaces are to comply, in general, with the provisions set out in the previous item 1, as applicable.

## SECTION 13

## INSTRUMENTATION

### 1 Gauging

#### 1.1 Types of gauging devices

##### 1.1.1 Arrangement

IBC CODE REFERENCE : Ch 13, 13.1.1

- a) In almost all cases a cargo code which requires a high level alarm and overflow control also requires a closed gauging device. A cargo tank containing such a product therefore requires three sensors:
  - 1) one level gauging
  - 2) one high level alarm
  - 3) one overflow control
- b) The sensing elements for 1), 2) and 3) are to be separated, although sensors for 2) and 3) (reed switches, float chambers, electronic devices, etc.) may be contained in the same tube.
- c) Electronic, pneumatic and hydraulic circuits required for sensors 1), 2) and 3) are to be independent of each other such that a fault on any one will not render either of the others inoperative.
- d) Where processing units are used to give digital or visual indication, such as in a bridge space, the independence of circuitry is to be maintained at least beyond this point.
- e) The power is to be supplied from distribution boards.
- f) Where a control room or a bridge space containing a modular unit is envisaged, separate level indication and visual alarms are to be provided for each of the functions 1), 2) and 3). An audible alarm is also to be provided but since this is not directional it need not be separate.
- g) An audible alarm is also to be arranged in the cargo area.
- h) Where there is no control room, an audible and visual alarm is to be arranged at the cargo control station.
- i) Testing of sensors is to be arranged from outside the tanks, although entry into product clean tanks is not precluded.
- j) Simulation testing of electronic circuits or circuits which are self-monitored is acceptable.

##### 1.1.2 Example of restricted gauging device

IBC CODE REFERENCE : Ch 13, 13.1.1

A restricted gauging device may consist of a sounding pipe with an inside diameter not greater than 200 mm, fitted with a gas-tight plug. The pipe is to have holes in order to make its internal pressure equal to that of the tank. Therefore the holes are to be located inside the cargo tank in the proximity of the top.

### 2 Vapour detection

#### 2.1 Vapour detection instruments

##### 2.1.1 Spaces to be monitored

IBC CODE REFERENCE : Ch 13, 13.2.1

Vapour detection instruments, either fixed or portable, are to be of a type recognised suitable by the Society for the products to be carried. The spaces to be monitored are:

- cargo pump rooms
- spaces containing motors driving cargo pumps, except for the machinery space
- enclosed spaces containing cargo piping, equipment connected with cargo handling, cofferdams, enclosed spaces and double bottoms adjacent to cargo tanks
- pipe tunnels
- other spaces, in the opinion of the Society, depending on the ship type.

Where a fixed system is installed, it is to serve the spaces among those listed above which are normally entered by the crew.

#### 2.2 Gas Measurements

##### 2.2.1 (1/1/2007)

The fitting of gas measuring equipment is subject to the provisions of Pt C, Ch 4, Sec 1, [5.2.4] b)1).

## SECTION 14

## PROTECTION OF PERSONNEL

### 1 General

#### 1.1

##### 1.1.1 (1/7/2012)

This Section is void, as the provisions of Chapter 14 of the IBC Code are not mandatory for the class.



## SECTION 15

## SPECIAL REQUIREMENTS

### 1 Ammonium nitrate solution (93% or less)

#### 1.1 Ammonia injection

##### 1.1.1 Injection procedure

IBC CODE REFERENCE: Ch 15, 15.2.6

Gaseous ammonia may be injected into the cargo while the latter is circulated by the cargo pump.

#### 1.2 Cargo pumps

##### 1.2.1 Seal

IBC CODE REFERENCE: Ch 15, 15.2.7

The seal for the centrifugal pump is to be a stuffing box provided with a lantern ring. Fresh water under pressure is to be injected into the stuffing box at the location of the lantern ring (see Fig 1).

### 2 Hydrogen peroxide solutions

#### 2.1 Hydrogen peroxide solutions over 60% but not over 70%

##### 2.1.1 Water spray system

IBC CODE REFERENCE: Ch 15, 15.5.10

It is specified that, for the purpose of evaluating the estimated size of the cargo spill in the case of failure, cargo piping/hose failure is to be assumed to be total.

### 3 Propylene oxide and mixtures of ethylene oxide/propylene oxide with an ethylene oxide content of not more than 30% by mass

#### 3.1 Tank cleaning

##### 3.1.1

IBC CODE REFERENCE: Ch 15, 15.8.3

Until an amendment in this respect is prepared at IMO, it is specified that the initial wording of the text of paragraph 15.8.3 of the IBC Code "Before loading, ....." is to be intended as follows: "Before initial loading of these products and before each loading of these products subsequent to loading of other products....."

#### 3.2 Joints in cargo lines

##### 3.2.1

IBC CODE REFERENCE: Ch 15, 15.8.12

Screwed connections are only allowed for accessory and instrumental lines with an external diameter of 25 mm or less.

#### 3.3 Oxygen content in tank vapour spaces

##### 3.3.1 Analysing equipment

IBC CODE REFERENCE: Ch 15, 15.8.28

Analysing equipment to determine oxygen and propylene oxide contents is to be of a type recognised as suitable by the Society. When portable analysers are used, there are to be at least two. When a fixed system is installed, a portable analyser is also to be provided.

Figure 1 : Seal

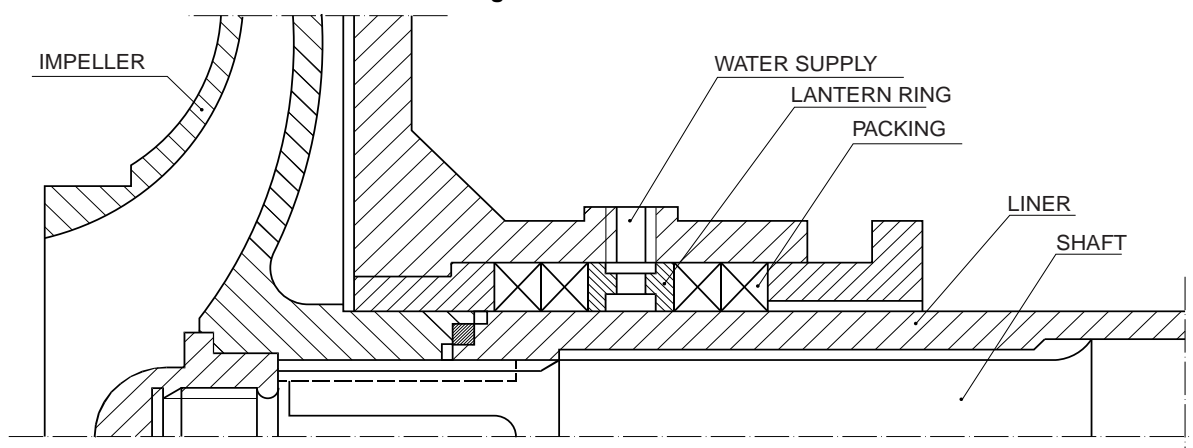

### 3.4 Valves at cargo hose connections

#### 3.4.1 Shut-off valve closing time

IBC CODE REFERENCE: Ch 15, 15.8.30

The closing time of shut-off valves provided at each cargo hose connection is to take account of the loading/unloading rate and is to be such as to avoid dangerous overpressure in cargo piping and hoses.

## 4 Sulphur (molten)

### 4.1 Fire-fighting system

#### 4.1.1 Cargo tank protection

IBC CODE REFERENCE: Ch 15, 15.10

Cargo tanks are to be protected by a fixed CO<sub>2</sub> extinguishing system in accordance with Part C, Chapter 4, or a steam extinguishing system. In the latter case, tank drying arrangements are to be provided to prevent corrosion after use of steam.

#### 4.1.2 CO<sub>2</sub> nozzles

IBC CODE REFERENCE: Ch 15, 15.10

Under normal service conditions, CO<sub>2</sub> tank feed nozzles are to be blanked off by means of a breaking disk to prevent pipes from being choked by sulphur. Nozzles are to be located at the upper part of the tank, above liquid level.

## 5 Acids

### 5.1 Lining

#### 5.1.1 (1/7/2011)

IBC CODE REFERENCE: Ch 15, 15.11.2

"Lining" is an acid-resistant material that is applied to the tank or piping system in a solid state with a defined elasticity property.

### 5.2 Electrical arrangements

#### 5.2.1

IBC CODE REFERENCE: Ch 15, 15.11.15

In enclosed spaces adjacent to cargo tanks, electrical materials and equipment complying with the provisions of paragraph 10.1.2 of the IBC Code are allowed.

### 5.3 Leak detection system

#### 5.3.1 Leak detectors

IBC CODE REFERENCE: Ch 15, 15.11.7

There are to be at least two leak detection apparatuses designed and calibrated to detect leakage of cargo into spaces adjacent to cargo tanks. The apparatuses may consist of a pH-meter, a gas detector suitable for the detection of hydrogen/air mixtures, of a type deemed suitable by the Society, or of other suitable systems. These apparatuses may be fixed or portable; if a fixed system is installed, a portable apparatus is also to be provided.

## 6 Toxic products

### 6.1 Return line to shore installation

#### 6.1.1 Valving on connection to shore installation

IBC CODE REFERENCE: Ch 15, 15.12.2

The above-mentioned systems are to be fitted with a shut-off valve and a blank flange in way of the vapour return line to the shore installation.

## 7 Cargoes protected by additives

### 7.1 Prevention of blockage by polymerisation

#### 7.1.1 Arrangements

IBC CODE REFERENCE: Ch 15, 15.13.6

In addition to being designed so as to avoid internal obstructions due to polymer formation, the above-mentioned systems are to be fitted with pressure/vacuum valves and devices to prevent the passage of flame which are accessible for inspection and maintenance.

## 8 Cargoes with a vapour pressure greater than 0,1013 MPa (1,013 bar) absolute at 37,8°C

### 8.1 General

#### 8.1.1 System for maintaining cargo temperature below boiling point (1/7/2021)

IBC CODE REFERENCE: Ch 15, 15.14.1

Any system installed for the purpose of keeping the cargo temperature below its boiling point is to be constructed to the satisfaction of the Society.

### 8.2 Return of expelled gases

#### 8.2.1 Valving of shore connection

IBC CODE REFERENCE: Ch 15, 15.14.4

The above-mentioned systems are to be fitted with a shut-off valve and a blank flange in way of the vapour return line to the shore installation.

## 9 Special cargo pump room requirements

### 9.1 Clarification

#### 9.1.1

IBC CODE REFERENCE: Ch 15, 15.18

As far as concerns the possibility of allowing the arrangement of cargo pump rooms below deck in specific cases, it is specified that, in practice, no circumstance can be foreseen where such an arrangement may be permitted.

## 10 Overflow control

### 10.1 Independence of systems

#### 10.1.1 Gauging devices

IBC CODE REFERENCE: Ch 15, 15.19

In almost all cases where, for the carriage of a product, a cargo high level alarm or cargo overflow control is required, a closed gauging device is also required.

#### 10.1.2 Separation of device sensing elements

IBC CODE REFERENCE: Ch 15, 15.19

A cargo tank intended to carry such a product therefore requires:

- a) level gauging
- b) high level alarm
- c) overflow control.

The sensing elements for the devices under a), b) and c) are to be separated, although sensors for b) and c) (micro-switches, float chambers, electronic devices, etc.) may be contained in the same metal tube sections.

#### 10.1.3 Electronic and hydraulic circuits for sensors

IBC CODE REFERENCE: Ch 15, 15.19

Electronic, pneumatic and hydraulic circuits required for sensors for a), b) and c) are to be independent of each other such that a fault on any one of them will not render either of the others inoperative. Where processing units are used to give digital or visual indication such as in a bridge space, the independence of circuitry is to be maintained at least up to such units. The power is to be supplied from distribution boards.

#### 10.1.4 Alarms in cargo control room

IBC CODE REFERENCE: Ch 15, 15.19

Where a cargo control room or a bridge space containing a modular unit is envisaged, separate level indications and visual alarms are to be provided for each of the functions a), b) and c). An audible alarm is also to be provided; there need not be a separate alarm for each function since separate alarms could not be distinguished. An audible alarm is also to be arranged in the cargo area.

#### 10.1.5 Alarms where cargo control room is not provided

IBC CODE REFERENCE: Ch 15, 15.19

- a) Where no cargo control room is provided, an audible and visual alarm is to be arranged at the cargo control station, which generally coincides with the navigating bridge.
- b) The audible and visual high level and cargo overflow alarms are to be located so as to be easily heard and noticed by the personnel in charge of loading/unloading operations. Attention is drawn to the fact that such alarms are generally grouped together into two independent signals; therefore it is not possible to single out directly the cargo tank from which the alarm signal is coming. In such cases, the Master is to arrange for a person to be present at the cargo control station, in order to be able to warn the personnel in charge of loading operations on deck.

#### 10.1.6 Testing of sensors

IBC CODE REFERENCE: Ch 15, 15.19

Testing of sensors is to be arranged from outside the tanks, although entry into product clean tanks is not prohibited. Simulation testing of electronic circuits or circuits which are self-monitoring is acceptable.

## **SECTION 16**

## **OPERATIONAL REQUIREMENTS AND ADDITIONAL MEASURES FOR THE PROTECTION OF THE MARINE ENVIRONMENT**

### **1 General**

#### **1.1**

**1.1.1** This Section is void, as the provisions of Chapter 16 and 16A of the IBC Code are operating requirements which are not mandatory for the class.

## SECTION 17

## SUMMARY OF MINIMUM REQUIREMENTS

### 1 General

#### 1.1

##### 1.1.1 (1/1/2007)

This Section is void, as there are no additional or alternative requirements to those indicated in Chapter 17 of the IBC Code.

## **SECTION 18**

## **LIST OF CHEMICALS TO WHICH THIS CHAPTER DOES NOT APPLY**

### **1 General**

#### **1.1**

**1.1.1** This Section is void, as there are no additional or alternative requirements to those indicated in Chapter 18 of the IBC Code.

## **SECTION 19**

## **INDEX OF PRODUCTS CARRIED IN BULK**

### **1 General**

#### **1.1**

**1.1.1** This Section is void, as there are no additional or alternative requirements to those indicated in Chapter 19 of the IBC Code.

## SECTION 20

## TRANSPORT OF LIQUID CHEMICAL WASTES

### 1 General

#### 1.1

**1.1.1** This Section is void, as there are no additional or alternative requirements to those indicated in Chapter 20 of the IBC Code.



## **SECTION 21**

## **CRITERIA FOR ASSIGNING CARRIAGE REQUIREMENTS FOR PRODUCTS SUBJECT TO THE IBC CODE**

### **1 General**

#### **1.1**

##### **1.1.1 (1/1/2007)**

This Section is void, as there are no additional or alternative requirements to those indicated in Chapter 21 of the IBC Code.



## LIQUEFIED GAS CARRIERS

---

<b>SECTION 1</b>	<b>GENERAL</b>
<b>SECTION 2</b>	<b>SHIP SURVIVAL CAPABILITIES AND LOCATION OF CARGO TANKS</b>
<b>SECTION 3</b>	<b>SHIP ARRANGEMENT</b>
<b>SECTION 4</b>	<b>CARGO CONTAINMENT</b>
<b>SECTION 5</b>	<b>PROCESS PRESSURE VESSELS AND LIQUID, VAPOUR AND PRESSURE PIPING SYSTEMS</b>
<b>SECTION 6</b>	<b>MATERIALS FOR CONSTRUCTION</b>
<b>SECTION 7</b>	<b>CARGO PRESSURE/TEMPERATURE CONTROL</b>
<b>SECTION 8</b>	<b>CARGO TANK VENTING SYSTEM</b>
<b>SECTION 9</b>	<b>ENVIRONMENTAL CONTROL</b>
<b>SECTION 10</b>	<b>ELECTRICAL INSTALLATIONS</b>
<b>SECTION 11</b>	<b>FIRE PROTECTION AND FIRE EXTINCTION</b>
<b>SECTION 12</b>	<b>MECHANICAL VENTILATION IN THE CARGO AREA</b>
<b>SECTION 13</b>	<b>INSTRUMENTATION (GAUGING, GAS DETECTION)</b>
<b>SECTION 14</b>	<b>PROTECTION OF PERSONNEL</b>
<b>SECTION 15</b>	<b>FILLING LIMITS FOR CARGO TANKS</b>
<b>SECTION 16</b>	<b>USE OF CARGO AS FUEL</b>
<b>SECTION 17</b>	<b>SPECIAL REQUIREMENTS</b>
<b>SECTION 18</b>	<b>OPERATING REQUIREMENTS</b>
<b>SECTION 19</b>	<b>SUMMARY OF MINIMUM REQUIREMENTS</b>
<b>APPENDIX 1</b>	<b>LNG BUNKER SHIPS</b>
<b>APPENDIX 2</b>	<b>REGASIFICATION SYSTEMS, PROCESS PRESSURE VESSELS AND LIQUID, VAPOUR AND PRESSURE PIPING SYSTEMS</b>



# SECTION 1

# GENERAL

## 1 Scope

### 1.1 Applicability

#### 1.1.1 IGC Code requirements and the Society's Rules (1/7/2021)

- a) Ships which are intended for the carriage of liquefied gases are to comply with the requirements of the latest version of the International Code for the Construction and Equipment of Ships Carrying Liquefied Gases in Bulk, as amended. In these Rules reference to this Code and its amendments is made by the wording "IGC Code".

Accordingly, for ships for which the service notation **liquefied gas carrier**, in accordance with Pt A, Ch 1, Sec 2, [4.5.5], is requested, the IGC Code requirements are to be considered as rule requirements, with the exception indicated in [1.1.2].

When the additional service feature **LNG BUNKER** is requested, the ship is to be in compliance with the requirements in App 1.

When the additional service feature **REGASIFICATION SYSTEM** is requested, the ship is to be fitted with a regasification system in compliance with the requirements in App 2.

- b) The requirements of this Chapter supplement those of the IGC Code, as amended. These requirements include additional mandatory class requirements, as well as the Society's interpretations of the IGC Code, which are also to be considered mandatory for class.
- c) This Chapter and the IGC Code refer to ships carrying those products which are listed in the table in Chapter 19 of the IGC Code and in Section 19 of this Chapter.
- d) This Chapter and the IGC Code include requirements for the carriage of cargo in containment systems incorporating integral, membrane or independent tank types as detailed in Chapter 4 of the IGC Code and in Sec 4.
- e) In general, this Chapter applies to cargo containment and handling systems and to the interfaces between these systems and the remainder of the ship, which is to comply with the applicable Sections of the hull and machinery Rules.

#### 1.1.2 IGC Code requirements not within the scope of classification (1/1/2021)

The following requirements of the IGC Code are not within the scope of classification:

- Chapter 1, Section 1.3 - Equivalents

- Chapter 1, Section 1.4 - Surveys and certification
- Chapter 2, Section 2.2.8 - Conditions of loading
- Chapter 2, Section 2.3 - Damage assumptions
- Chapter 2, Section 2.5 - Flood assumptions
- Chapter 2, Section 2.6 - Standard of damage
- Chapter 2, Section 2.7 - Survival requirements
- Chapter 11 - Fire protection and extinction
- Chapter 14 - Personnel protection
- Chapter 18 - Operating requirements (apart for few exceptions stated in Sec 18).

These requirements are applied by the Society when acting on behalf of the flag Administration, within the scope of delegation (see [1.1.7]).

#### 1.1.3 Carriage of products not listed in the Code

The requirements of the IGC Code and the additional requirements of this Chapter are also applicable to new products, which may be considered to come within the scope of these rules, but are not at present listed in the table in Chapter 19 of the IGC Code.

#### 1.1.4 Particularly hazardous products

For the carriage in bulk of products which are not listed in the table in Chapter 19 of the IGC Code, presenting more severe hazards than those covered by the IGC Code, the Society reserves the right to establish requirements and/or conditions additional to those contained in these rules.

#### 1.1.5 Correspondence of the IGC Code with Part E Chapter 9 of the Rules

All the requirements of this Chapter are cross referenced to the applicable Chapters, Sections or paragraphs of the IGC Code, as appropriate.

#### 1.1.6 Equivalencies

As far as the requirements for class are concerned, the following wording in the IGC Code is to be given the meanings indicated in Tab 1.

**Table 1**

IGC Code word	Meaning for Classification only
Administration	Society
IBC Code or Chemical Code	Part E Chapter 8 of the Rules
Recognised Standard	Rules
should be	is to be or are to be (as applicable)

### 1.1.7 Certificate of fitness

- a) The responsibility for interpretation of the IGC Code requirements for the purpose of issuing an International Certificate of Fitness for the Carriage of Liquefied Gases in Bulk lies with the Administration of the state whose flag the ship is entitled to fly.
- b) Whenever the Society is authorised by an Administration to issue on its behalf the "Certificate of Fitness for the Carriage of Liquefied Gases in Bulk", or where the Society is authorised to carry out investigations and surveys on behalf of an Administration on the basis of which the "Certificate of Fitness for the Carriage of Liquefied Gases in Bulk" will be issued by the Administration, or where the Society is requested to certify compliance with the IGC Code, the full compliance with the requirements of the IGC Code, including the operative requirements mentioned in [1.1.2], is to be granted by the Society.

## 2 Additional requirements

### 2.1 Emergency towing arrangement

**2.1.1** Emergency towing arrangements are to be fitted on liquefied gas tankers of 20.000 dwt and above in accordance with Pt B, Ch 10, Sec 4, [4].

### 2.2 Steering gear

**2.2.1** Additional requirements for steering gear of liquefied gas carriers of 10.000 dwt and above are given in Ch 7, Sec 4, [7].

## 3 Documentation to be submitted

### 3.1

**3.1.1** Tab 2 lists the plans, information, analysis, etc. which are to be submitted in addition to the information required in the other Parts of the Rules for the parts of the ship not affected by the cargo, as applicable.

## 4 Cargo equipment trials

### 4.1 Scope

#### 4.1.1 Trials in working conditions

All the equipment to which this Chapter is applicable is to be tested in actual working conditions.

#### 4.1.2 Trials to be carried out when the ship is loaded

Those trials which may only be carried out when the ship is loaded are to be held at the first loading of the ship.

### 4.2 Extent of the tests

#### 4.2.1 Cargo equipment testing procedure

The cargo equipment testing procedure is to be submitted to the Society for review.

#### 4.2.2 Ships with mechanical refrigeration units

Ships fitted with a mechanical refrigeration unit are to be subjected to an initial testing procedure in order to check the suitability of the plant in respect of the applicable requirements. The recording of the data of the reliquefaction system, such as working duration and ambient conditions, may be carried out during the first loaded voyage.

#### 4.2.3 Use of cargo as fuel

The arrangements for using cargo as fuel are to be subjected to a special testing procedure.

**Table 2 : Documents to be submitted (1/7/2020)**

No	A/I	Documents
1	I	List of products to be carried, including maximum vapour pressure, maximum liquid temperature and other important design conditions
2	I	General arrangement plan, showing location of cargo tanks and fuel oil, ballast and other tanks
3	I	P&A manual, when applicable
4	A	Gas-dangerous zones plan
5	A	Location of void spaces and accesses to dangerous zones
6	A	Air locks between safe and dangerous zones
7	A	Ventilation duct arrangement in gas-dangerous spaces and adjacent zones
8	A	Details of hull structure in way of cargo tanks, including support arrangement for tanks, saddles, anti-floating and anti-lifting devices, deck sealing arrangements, etc.
9	A	Calculation of the hull temperature in all the design cargo conditions
10	A	Distribution of quality and steel grades in relation to the contemplated actual temperature obtained by the calculation in item 9
11	A	Hull stress analysis
12	A	Hull ship motion analysis, where a direct analysis is preferred to the methods indicated in Sec 4
13	A	Intact and damage stability calculations
14	A	Scantlings, material and arrangement of the cargo containment system, including the secondary barrier, if any.
15	A	Stress analysis of the cargo tanks, including fatigue analysis and crack propagation analysis for type "B" tanks. This analysis may be integrated with that indicated in item 11
16	I	Calculation of the thermal insulation suitability, including boil-off rate and refrigeration plant capability, if any, cooling down and temperature gradients during loading and unloading operations
17	A	Details of insulation
18	A	Details of ladders, fittings and towers in tanks and relative stress analysis, if any
19	A	Details of tank domes and deck sealings
20	A	Plans, arrangement and calculations of safety relief valves
21	A	Details of cargo handling and vapour system, including arrangements and details of piping and fitting
22	A	Details of cargo pumps and cargo compressors
23	A	Details of process pressure vessels and relative valving arrangement
24	A	Piping stress analysis when $T < -110^{\circ}\text{C}$
25	A	Control cargo tank pressure philosophy (description)
26	A	Cargo operating manual
27	A	Bilge and ballast system in cargo area
28	A	Gas freeing system in cargo tanks including inert gas system
29	A	Interbarrier space drainage, inerting and pressurisation systems
30	A	Ventilation system in cargo area
31	A	Hull structure heating system, if any
32	A	Refrigeration and reliquefaction plant system diagram, if any
33	A	Details of electrical equipment installed in cargo area, including the list of certified safe equipment and apparatus and electrical bonding of cargo tanks and piping
<b>Note 1:</b> A = to be submitted for approval in four copies I = to be submitted for information in duplicate		

No	A/I	Documents
34	A	Schematic electrical wiring diagram in cargo area
35	A	Gas detection system
36	A	Cargo tank instrumentation, including cargo and hull temperature monitoring system
37	A	Emergency shutdown system
38	A	Jettison system, if any
39	A	Details of fire-extinguishing appliances and systems in cargo area
40	A	Loading and unloading operation description, including cargo tank filling limits
41	A	Cargo tank testing and inspection procedures
42		For machinery using gas as fuel
	I	a) General arrangement plan of the machinery plant
	I	b) Description of the entire plant
	A	c) Gas piping plans for the machinery plant
	A	d) Complete list of the safety, gas detection and warning equipment
	A	e) Drawings of the boilers
	I	f) Detailed drawings of the gas inlet and fuel inlet equipment
	I	g) Gas characteristics
	A	h) General arrangement plan of the gas treatment plant, including gas compressors, prime movers and gas preheaters
	A	i) Drawings of the gas storage tanks
	A	j) Drawings of the gas compressors and preheaters
<b>Note 1:</b> A = to be submitted for approval in four copies I = to be submitted for information in duplicate		

## 5 Construction and testing

### 5.1

#### 5.1.1 (1/1/2021)

In case any of the following equipment is fitted:

- regasification, reliquefaction and inert gas production system,
- equipment for use of gas as fuel for boilers and internal combustion engines

is also to be tested to the satisfaction of the Surveyor.



## SECTION 2

## SHIP SURVIVAL CAPABILITIES AND LOCATION OF CARGO TANKS

### 1 Freeboard and intact stability

#### 1.1 Intact stability

##### 1.1.1 General

IGC CODE REFERENCE : Ch 2, 2.2.2

The stability of the ship for the loading conditions in Pt B, Ch 3, App 2, [1.2.8] is to be in compliance with the requirements in Pt B, Ch 3, Sec 2.

##### 1.1.2 Free surface effect of liquids

IGC CODE REFERENCE : Ch 2, 2.2.3

The free surface effect is to be calculated in accordance with Pt B, Ch 3, Sec 2, [4].

##### 1.1.3 Information to be supplied

IGC CODE REFERENCE : Ch 2, 2.2.5

The Master of the ship is to be supplied with a Loading Manual as specified in Pt B, Ch 11, Sec 2, [3] and a Trim and Stability booklet as specified in Pt B, Ch 3, App 2.

## SECTION 3 SHIP ARRANGEMENT

### 1 Segregation of the cargo area

#### 1.1 Segregation of hold spaces

##### 1.1.1 Bow thruster location

IGC CODE REFERENCE : Ch 3, 3.1.1

Bow thrusters are allowed to be fitted forward of the hold spaces.

### 2 Accommodation, service and machinery spaces and control stations

#### 2.1 General

##### 2.1.1 Precautions against hazardous vapours

IGC CODE REFERENCE : Ch 3, 3.2.2

Compliance with the relevant requirements of the IGC Code, in particular with 3.2.4, 3.8, 8.2.10 and 12.1.6, as applicable, also ensures compliance with the requirements in IGC Code 3.2.2, relevant to precautions against hazardous vapours.

##### 2.1.2 Air outlets

IGC CODE REFERENCE : Ch 3, 3.2.4

The requirements in IGC Code 3.2.4, relevant to air intakes, are also intended to be applicable to air outlets. This interpretation also applies to the requirements in IGC Code 3.8.4

##### 2.1.3 Doors facing cargo area

IGC CODE REFERENCE : Ch 3, 3.2.4

Doors facing the cargo area or located in prohibited zones in the sides are to be restricted to stores for cargo-related and safety equipment, cargo control stations as well as decontamination showers and eye wash.

Where such doors are permitted, the space may not give access to other spaces covered in IGC Code 3.2.4 and the common boundaries with these spaces are to be insulated with A60 class bulkheads.

##### 2.1.4 Exemptions, ventilation openings and type of closures

IGC CODE REFERENCE : Ch 3, 3.2.6

The requirement for fitting air intakes and openings with closing devices operable from inside the space in ships

intended to carry toxic products is to apply to spaces which are used for the ship's radio and main navigating equipment, cabins, mess rooms, toilets, hospitals, galleys, etc., but does not apply to spaces not normally manned such as engine room casings, steering gear compartments.

The closing devices are to give a reasonable degree of gas-tightness. Ordinary steel fire-flaps without gaskets/seals are normally not considered satisfactory.

##### 2.1.5 Openings for removal of machinery

IGC CODE REFERENCE : Ch 3, 3.2.6

Bolted plates of A60 class for removal of machinery may be accepted on bulkheads facing cargo areas, provided sign-boards are fitted to warn that these plates may only be opened when the ship is in gas-free condition.

### 3 Cargo pump rooms and cargo compressor rooms

#### 3.1 Location of cargo pump rooms and cargo compressor rooms

##### 3.1.1 Electrical equipment in cargo pump rooms and cargo compressor rooms

IGC CODE REFERENCE : Ch 3, 3.3

Cargo pump rooms and/or cargo compressor rooms of ships carrying flammable gases may not contain electrical equipment, except as provided for in Chapter 10 of the IGC Code, or other ignition sources such as internal combustion engines or steam engines with operating temperature which could cause ignition or explosion of mixtures of such gases, if any, with air.

### 4 Access arrangement

#### 4.1 Access to compartments in the cargo area

##### 4.1.1 Passage through hatches and manholes (1/1/2020)

IGC CODE REFERENCE : Ch 3, 3.5

For the purpose of the requirements in IGC Code 3.5.3, the following applies:

- a) The term "minimum clear opening of not less than 600 x 600 mm" means that such openings may have corner radii up to a maximum of 100 mm (see Fig 1).

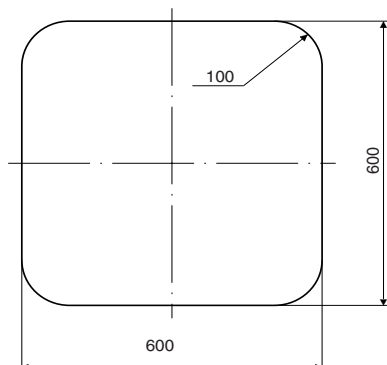
**Figure 1 : Minimum horizontal hatch size**

- b) The term “minimum clear opening of not less than 600 x 800 mm” also includes an opening of the size specified in Fig 2:

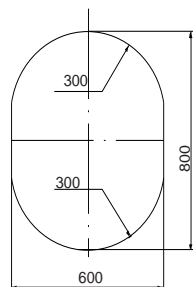
**Figure 2 : Minimum size of manholes**

#### 4.1.2 Cofferdams

IGC CODE REFERENCE : Ch 3, 3.5

Where fitted, cofferdams are to have sufficient size for easy access to all their parts. The width of the cofferdams may not be less than 600 mm.

#### 4.1.3 Pipe tunnels

IGC CODE REFERENCE : Ch 3, 3.5

Pipe tunnels are to have enough space to permit inspection of pipes. The pipes in pipe tunnels are to be installed as high as possible from the ship's bottom.

#### 4.1.4 Access to pipe tunnels

IGC CODE REFERENCE : Ch 3, 3.5

Access to pipe tunnels through manholes in the engine space is not permitted.

### 4.2 Access to the bow

#### 4.2.1 (1/7/2008)

This item [4.2] applies to ships subject to the International Load Line Convention 1966, as amended.

#### 4.2.2 (1/7/2006)

Liquefied gas carriers are to be provided either with a gangway between the superstructure or deckhouse aft and the forecastle, or with equivalent arrangements in accordance with the International Load Line Convention 1966, as amended.

#### 4.2.3 (1/7/2006)

*Liquefied gas carriers are to be provided with the means to enable the crew to gain safe access to the bow even in severe weather conditions. Such means are to be accepted by the Society.*

Note 1: The Society considers means in compliance with the Guidelines adopted by the Maritime Safety Committee of IMO with Resolution MSC.62(67) on 5/12/1996 as being acceptable.

## 5 Air-locks

### 5.1 Arrangement

#### 5.1.1

IGC CODE REFERENCE : Ch 3, 3.6.1

Air-locks are to be such as to provide easy passage and are to cover a deck area of not less than 1,5 m<sup>2</sup>. Air-locks are to be kept unobstructed and may not be employed for other uses, such as storage.

### 5.2 Alarm

#### 5.2.1 Alarm signalling lamp

IGC CODE REFERENCE : Ch 3, 3.6.3

The alarm systems are to be of the intrinsically safe type. However, signalling lamps may be of a safe type authorised for the dangerous spaces in which they are installed.

### 5.3 Electrical equipment

#### 5.3.1 Acceptable alternatives to differential pressure

IGC CODE REFERENCE : Ch 3, 3.6.4

The following means are considered acceptable alternatives to differential pressure sensing devices in spaces having a ventilation rate not less than 30 air changes per hour:

- monitoring of current or power in the electrical supply to the ventilation motors; or
- air flow sensors in the ventilation ducts.

In spaces where the ventilation rate is less than 30 air changes per hour and where one of the above alternatives is fitted, in addition to the alarms required in IGC Code 3.6.3, arrangements are to be made to de-energise electrical equipment which is not of the certified safe type if more than one air-lock door is moved from the closed position.

#### 5.3.2 Compressors for boil-off system

IGC CODE REFERENCE : Ch 3, 3.6.4

Lack of overpressure or air flow is not to imply the stopping of motors driving compressors used for the boil-off system mentioned in IGC Code 16; therefore, such engines are to be of the certified safe type and the relevant control appliance is to be fitted in a non-gas-dangerous space.

The requirement above is not applicable if, during manoeuvring and operations in port, only fuel oil is used or when the automatic transfer from gas to fuel oil, as per IGC Code 16.5.4, operates also when such electric motors are stopped without causing the shut-off of the boiler.

## 5.4 Ventilation

### 5.4.1 Air changes

IGC CODE REFERENCE : Ch 3, 3.6.5

The spaces protected by air-locks are to be ventilated for the time necessary to give at least 10 air changes prior to energising the non-safe type electrical installations.

## 6 Bilge, ballast and fuel oil arrangements

### 6.1 Drainage arrangement

#### 6.1.1 Drainage of dry spaces in the cargo area

IGC CODE REFERENCE : Ch 3, 3.7

Dry spaces within the cargo area are to be fitted with a bilge or drain arrangement not connected to the machinery space.

Spaces not accessible at all times are to be fitted with sounding arrangements.

Spaces without a permanent ventilation system are to be fitted with a pressure/vacuum relief system or with air pipes.

### 6.2 Additional requirements relative to the bilge system

#### 6.2.1 Operation of the bilge system in cargo and interbarrier spaces

IGC CODE REFERENCE : Ch 3, 3.7

Bilge arrangements for holds containing cargo tanks and for interbarrier spaces are to be operable from the weather deck.

#### 6.2.2 Means for leakage detection

IGC CODE REFERENCE : Ch 3, 3.7

With reference to the means to ascertain leakages in holds and/or in interbarrier spaces, the following requirements apply:

- the above-mentioned means is to be suitable to ascertain the presence of water:
  - in holds containing type C independent tanks
  - in holds and interbarrier spaces outside the secondary barrier
- the above-mentioned means is to be suitable to ascertain the presence of liquid cargo in the spaces adjacent to cargo tanks which are not type C independent tanks. Where the aforesaid spaces may be affected by water leakages from the adjacent ship structures, the means is also to be suitable to ascertain the presence of water. Where the above-mentioned means is constituted by electrical level switches, the relevant circuits are to be of the intrinsically safe type and signals are to be transduced to the wheelhouse and to the cargo control station, if fitted.

## 7 Bow or stern loading and unloading arrangements

### 7.1 Locations of stopping devices for cargo pumps and compressors

#### 7.1.1

IGC CODE REFERENCE : Ch 3, 3.8.7

Devices to stop cargo pumps and cargo compressors and to close cargo valves are to be fitted in a position from which it is possible to keep under control the loading/unloading manifolds.

## 8 Hull outfitting

### 8.1 Equipment

#### 8.1.1 Emergency towing arrangements

The specific requirements in Pt B, Ch 10, Sec 4, [4] for ships with the service notation **liquefied gas carrier** and not less than 20000 t deadweight are to be complied with.

## SECTION 4

## CARGO CONTAINMENT

### Symbols

$k$  : Material factor for steel, defined in Pt B, Ch 4, Sec 1, [2.3]

### 1 Definitions

#### 1.1 Design pressure in harbour conditions

1.1.1 (1/1/2020)

IGC CODE REFERENCE : Ch 4, 4.13.2.3

Where the vapour pressure in harbour conditions is greater than  $p_0$ , defined in IGC 4.1.2, this value is to be specified in the operating instructions for the ship's Master.

#### 1.2 Design temperature

##### 1.2.1 Use of cargo heater to raise the cargo temperature (1/1/2020)

IGC CODE REFERENCE : Ch 4, 4.1.3

Where a cargo heater, intended to raise the cargo temperature to a value permissible for cargo tanks, is envisaged, the following requirements are to be complied with:

- the piping and valves involved are to be suitable for the design loading temperature
- a thermometer is to be fitted at the heater outlet. It is to be set at the design temperature of the tanks and, when activated, it is to give a visual and audible alarm. This alarm is to be installed in the cargo control station or, when such a station is not foreseen, in the wheelhouse.
- The following note is to be written on the Certificate of Fitness: "The minimum permissible temperature in the cargo preheater is..... °C".

### 2 Design loads

#### 2.1 Internal pressure for integral tanks, membrane tanks and type A independent tanks

##### 2.1.1 General

The inertial internal liquid pressure is to be calculated according to Part B, Chapter 5.

#### 2.2 Internal pressure for type B and C independent tanks

##### 2.2.1 General (1/1/2020)

IGC CODE REFERENCE : Ch 4, 4.13.2 and 4.28

The inertial internal liquid pressure is to be calculated considering the ship in the following mutually exclusive conditions:

**Figure 1 : Dimensionless acceleration in upright ship condition**

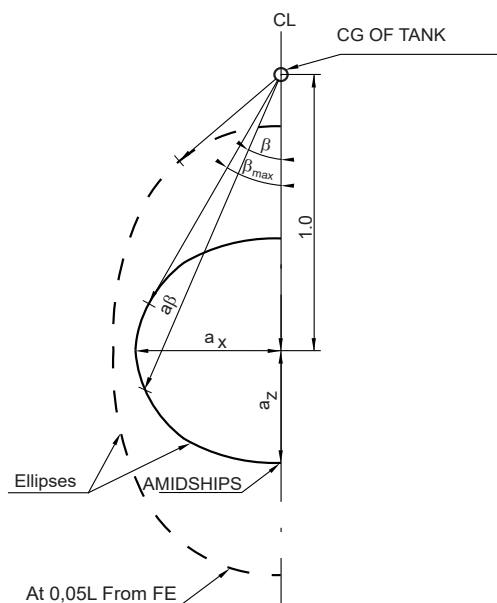

**Figure 2 : Dimensionless acceleration in inclined ship condition**

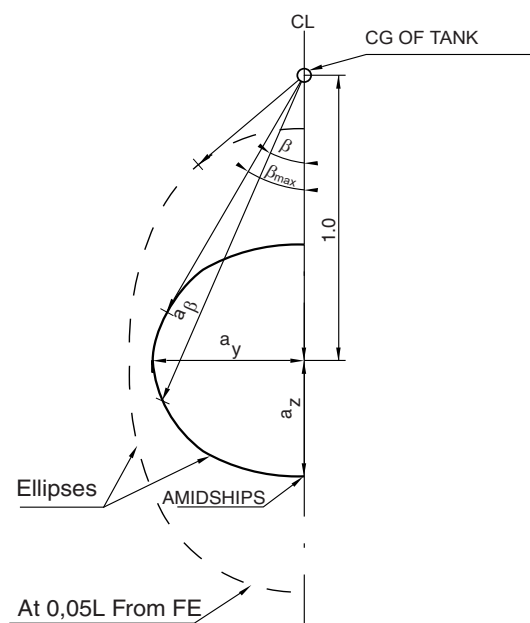
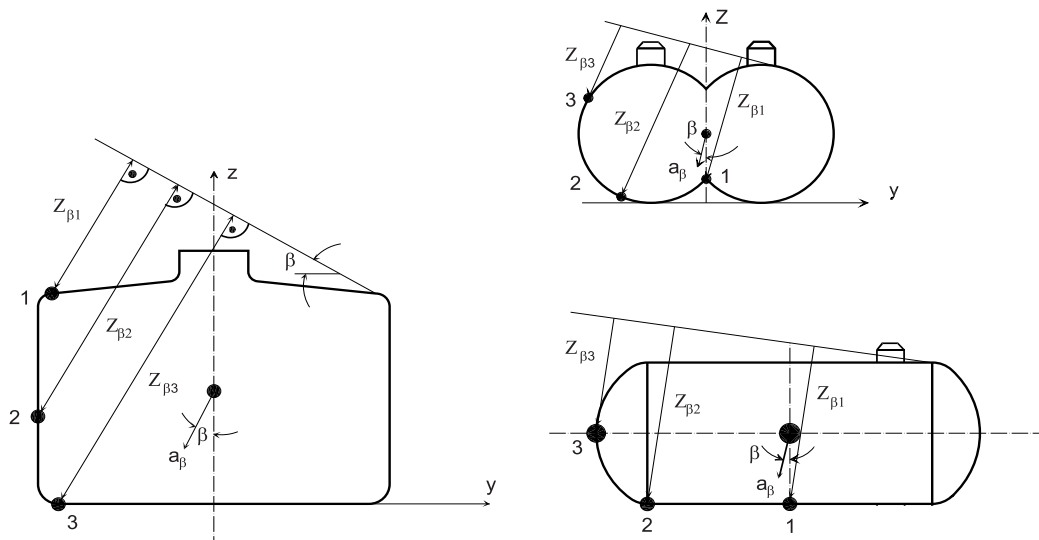

Figure 3 : Determination of liquid height  $Z_{\beta}$  for pressure points 1, 2 and 3



- upright ship conditions (see [2.2.2])
- inclined ship conditions (see [2.2.3]).

**2.2.2 Accelerations in upright ship conditions (1/1/2020)**

In these conditions, the ship encounters waves which produce ship motions in the X-Z plane, i.e. surge, heave and pitch.

The dimensionless acceleration  $a_{\beta}$  is to be obtained, for an arbitrary direction  $\beta$ , in accordance with Fig 1, in which the wave transverse and vertical accelerations  $a_x$  and  $a_z$ , respectively, are calculated from the formula in IGC Code 4.28.2.

**2.2.3 Accelerations in inclined ship conditions (1/1/2020)**

In these conditions, the ship encounters waves which produce ship motions in the X-Y and Y-Z planes, i.e. sway, heave, roll and yaw.

The dimensionless acceleration  $a_{\beta}$  is to be obtained, for an arbitrary direction  $\beta$ , in accordance with Fig 2, in which the wave longitudinal and vertical accelerations  $a_y$  and  $a_z$ , respectively, are calculated from the formula in IGC Code 4.28.2.

**2.2.4 Liquid heights and pressure (1/1/2020)**

IGC CODE REFERENCE : Ch 4, 4.28.1.2

The liquid heights  $Z_{\beta}$  are to be calculated in accordance with Fig 3 at each calculation point of the tank.

At each calculation point, the maximum internal pressure  $(P_{gd})_{max}$  is to be obtained for the  $\beta$  direction which gives the maximum value of  $P_{gd}$ , according to IGC Code 4.28.1.2 (see Fig 4).

**2.2.5 Cargo mass density (1/1/2020)**

Where the maximum mass density of the liquid carried is not given, the following values, in  $t/m^3$ , are to be considered:

- $\rho_L = 0,50 t/m^3$  for methane
- $\rho_L = 0,58 t/m^3$  for propane
- $\rho_L = 0,60 t/m^3$  for butane
- $\rho_L = 0,70 t/m^3$  for ammonia (anhydrous).

**3 Hull scantlings**

**3.1 Plating**

**3.1.1 Minimum net thicknesses (1/1/2020)**

IGC CODE REFERENCE : Ch 4, 4.24, 4.25 and 4.26

The net thickness of the weather strength deck, trunk deck, tank bulkhead and watertight bulkhead plating within or bounding the longitudinal extension of the cargo area is to be not less than the values given in Tab 1.

**3.2 Ordinary stiffeners**

**3.2.1 Minimum net thicknesses**

The net thickness of the web of ordinary stiffeners is to be not less than the value obtained, in mm, from the following formulae:

$$t_{MIN} = 0,8 + 0,013 L k^{1/2} + 4,5 s \quad \text{for } L < 220 \text{ m}$$

$$t_{MIN} = 3 k^{1/2} + 4,5 + s \quad \text{for } L \geq 220 \text{ m}$$

where  $s$  is the spacing, in m, of ordinary stiffeners.

**Figure 4 : Determination of internal pressure for pressure points 1, 2 and 3**

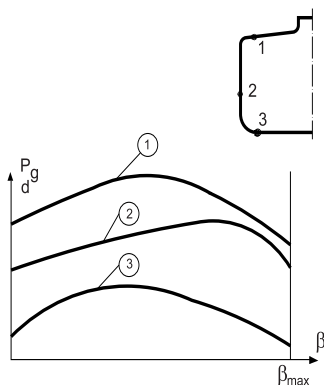

**Table 1 : Minimum net thickness of the weather strength deck, trunk deck, tank bulkhead and watertight bulkhead plating**

Plating	Minimum net thickness, in mm	
Weather strength deck and trunk deck at midship	Longitudinal framing	1,6 + 0,032 L k <sup>1/2</sup> + 4,5 s for L < 220 6 k <sup>1/2</sup> + 5,7 + s for L ≥ 220
	Transverse framing	1,6 + 0,04 L k <sup>1/2</sup> + 4,5 s for L < 220 6 k <sup>1/2</sup> + 7,5 + s for L ≥ 220
Weather strength deck and trunk deck at ends and between hatchways	2,1 + 0,013 L k <sup>1/2</sup> + 4,5 s	
Tank bulkhead	1,7 + 0,013 L k <sup>1/2</sup> + 4,5 s	
Watertight bulkhead	1,3 + 0,013 L k <sup>1/2</sup> + 4,5 s	
<b>Note 1:</b> s : Length, in m, of the shorter side of the plate panel.		

### 3.3 Primary supporting members

#### 3.3.1 Minimum net thicknesses

The net thickness of plating which forms the webs of primary supporting members is to be not less than the value obtained, in mm, from the following formula:

$$t_{\text{MIN}} = 4,1 + 0,015 L k^{1/2}$$

## 4 Structural analysis of integral tanks

### 4.1 Scantlings

#### 4.1.1 (1/1/2020)

IGC CODE REFERENCE : Ch 4, 4.25.2

The net scantlings of plating, ordinary stiffeners and primary supporting members of integral tanks are to be not less than those obtained from Part B, Chapter 7, where the hull girder loads and the internal pressure are to be calculated according to Part B, Chapter 5.

## 5 Structural analysis of membrane tanks

### 5.1 General

**5.1.1** Specific allowable hull girder stresses and/or deflections, indicated by the Designer, are to be taken into account for the determination of the scantlings.

### 5.2 Scantlings

#### 5.2.1 (1/1/2020)

IGC CODE REFERENCE : Ch 4, 4.24

The net scantlings of plating, ordinary stiffeners and primary supporting members of membrane tanks are to be not less than those obtained from Part B, Chapter 7, where the hull girder loads and the internal pressure are to be calculated according to Part B, Chapter 5.

## 6 Structural analysis of type A independent tanks

### 6.1 Scantlings

#### 6.1.1 (1/1/2020)

IGC CODE REFERENCE : Ch 4, 4.21

The net scantlings of plating, ordinary stiffeners and primary supporting members of type A independent tanks are to be not less than those obtained from Part B, Chapter 7, where the hull girder loads and the internal pressure are to be calculated according to Part B, Chapter 5.

When calculating the internal pressure, the presence of the dome may be disregarded.

## 7 Structural analysis of type B independent tanks

### 7.1 Plating and ordinary stiffeners

#### 7.1.1 Strength check of plating and ordinary stiffeners subject to lateral pressure (1/1/2020)

IGC CODE REFERENCE : Ch 4, 4.22

The net scantlings of plating and ordinary stiffeners of type B independent tanks are to be not less than those obtained from the applicable formulae in Part B, Chapter 7, where the internal pressure is to be calculated according to [2.2].

#### 7.1.2 Buckling check (1/1/2020)

IGC CODE REFERENCE : Ch 4, 4.22.3.2

The scantlings of plating and ordinary stiffeners of type B independent tanks are to be not less than those obtained from the applicable formulae in Part B, Chapter 7.

### 7.2 Primary supporting members

#### 7.2.1 Analysis criteria (1/1/2020)

IGC CODE REFERENCE : Ch 4, 4.22

The analysis of the primary supporting members of the tank subjected to lateral pressure based on a three dimensional model is to be carried out according to the following requirements:

- the structural modelling is to comply with the requirements from Pt B, Ch 7, App 1, [1] to Pt B, Ch 7, App 1, [3]
- the stress calculation is to comply with the requirements in Pt B, Ch 7, App 1, [5]
- the model extension is to comply with [7.2.2]
- the wave hull girder loads and the wave pressures to be applied on the model are to comply with [7.2.3]
- the inertial loads to be applied on the model are to comply with [7.2.4].

#### 7.2.2 Model extension

The longitudinal extension of the structural model is to comply with Pt B, Ch 7, App 1, [3.2]. In any case, the struc-

tural model is to include the hull and the tank with its supporting and keying system.

#### 7.2.3 Wave hull girder loads and wave pressures (1/1/2020)

IGC CODE REFERENCE : Ch 4, 4.22

Wave hull girder loads and wave pressures are to be obtained from a complete analysis of the ship motion and accelerations in irregular waves, to be submitted to the Society for approval, unless these data are available from similar ships.

These loads are to be obtained as the most probable the ship may experience during its operating life, for a probability level of  $10^{-8}$ .

#### 7.2.4 Inertial loads (1/1/2020)

IGC CODE REFERENCE : Ch 4, 4.22

The inertial loads are to be obtained from the formulae in IGC 4.13.2.

#### 7.2.5 Yielding check of primary supporting members of type B independent tanks primarily constructed of bodies of revolution (1/1/2020)

IGC CODE REFERENCE : Ch 4, 4.22

The equivalent stresses of primary supporting members are to comply with the following formula:

$$\sigma_E \leq \sigma_{ALL}$$

where:

$\sigma_E$  : Equivalent stress, in N/mm<sup>2</sup>, to be obtained from the formula in IGC 4.18.1.4 for each of the following stress categories, defined in IGC 4.28.3:

- primary general membrane stress
- primary local membrane stress
- primary bending stress
- secondary stress

$\sigma_{ALL}$  : allowable stress, defined in IGC 4.22.3.1.1 for each of the stress categories above.

#### 7.2.6 Yielding check of primary supporting members of type B independent tanks primarily constructed of plane surfaces (1/1/2020)

IGC CODE REFERENCE : Ch 4, 4.22

The equivalent stresses of primary supporting members are to comply with the following formula:

$$\sigma_E \leq \sigma_{ALL}$$

where:

$\sigma_E$  : Equivalent stress, in N/mm<sup>2</sup>, to be obtained from the formulae in Pt B, Ch 7, App 1, [5.1], as a result of direct calculations to be carried out in accordance with [7.2.1]

$\sigma_{ALL}$  : Allowable stress, in N/mm<sup>2</sup>, to be obtained from Tab 2.



**Table 2 : Allowable stress for primary supporting members primarily constructed of plane surfaces**

Material	Allowable stress, in N/mm <sup>2</sup>
C-Mn steel and Ni-steels	The lesser of: <ul style="list-style-type: none"> <li>• 0,75 R<sub>eH</sub></li> <li>• 0,5 R<sub>m</sub></li> </ul>
Austenitic steels	The lesser of: <ul style="list-style-type: none"> <li>• 0,80 R<sub>eH</sub></li> <li>• 0,4 R<sub>m</sub></li> </ul>
Aluminium alloy	The lesser of: <ul style="list-style-type: none"> <li>• 0,75 R<sub>eH</sub></li> <li>• 0,35 R<sub>m</sub></li> </ul>
<b>Note 1:</b>	
R <sub>eH</sub>	: Minimum yield stress, in N/mm <sup>2</sup> , of the material, as defined in Pt B, Ch 4, Sec 1, [2.1]
R <sub>m</sub>	: Ultimate minimum tensile strength, in N/mm <sup>2</sup> , of the material, as defined in Pt B, Ch 4, Sec 1, [2.1].

### 7.2.7 Buckling check of local buckling of plate panels of primary supporting members (1/1/2020)

IGC CODE REFERENCE : Ch 4, 4.22

A local buckling check is to be carried out according to Pt B, Ch 7, Sec 1, [5] for plate panels which constitute primary supporting members.

In performing this check, the stresses in the plate panels are to be obtained from direct calculations to be carried out in accordance with [7.2.1].

## 7.3 Fatigue analysis

### 7.3.1 General (1/1/2020)

IGC CODE REFERENCE : Ch 4, 4.18.2 and 4.22.4

The fatigue analysis is to be performed for areas where high wave induced stresses or large stress concentrations are expected, for welded joints and parent material. Such areas are to be defined by the Designer and agreed by the Society on a case-by-case basis.

### 7.3.2 Material properties (1/1/2020)

IGC CODE REFERENCE : Ch 4, 4.18.2

The material properties affecting fatigue of the items checked are to be documented. Where this documentation is not available, the Society may request to obtain these properties from experiments performed in accordance with recognised standards.

### 7.3.3 Wave loads (1/1/2020)

In upright ship and in inclined ship conditions the wave loads to be considered for the fatigue analysis of the tank include:

- maximum and minimum wave hull girder loads and wave pressures, to be obtained from a complete analysis of the ship motion and accelerations in irregular waves, to be submitted to the Society for approval, unless these data are available from similar ships. These loads are to be obtained as the most probable the ship may experi-

ence during its operating life, for a probability level of 10<sup>-8</sup>.

- Maximum and minimum inertial pressures, to be obtained from the formulae in IGC Code 4.28.1.2 as a function of the arbitrary direction  $\beta$ .

### 7.3.4 Simplified stress distribution for fatigue analysis (1/1/2020)

IGC CODE REFERENCE : Ch 4, 4.18.2.5

The simplified long-term distribution of wave loads indicated in IGC Code 4.18.2.5 may be represented by means of 8 stress ranges, each characterised by an alternating stress  $\pm\sigma_i$  and a number of cycles  $n_i$  (see Fig 5). The corresponding values of  $\sigma_i$  and  $n_i$  are to be obtained from the following formulae:

$$\sigma_i = \sigma_0 \left( 1,0625 - \frac{i}{8} \right)$$

$$n_i = 0,9 \cdot 10^i$$

where:

- $\sigma_i$  : Stress ( $i = 1, 2, \dots, 8$ ), in N/mm<sup>2</sup> (see Fig 5)
- $\sigma_0$  : Most probable maximum stress over the life of the ship, in N/mm<sup>2</sup>, for a probability level of 10<sup>-8</sup>
- $n_i$  : Number of cycles for each stress  $\sigma_i$  considered ( $i = 1, 2, \dots, 8$ ).

### 7.3.5 Conventional cumulative damage (1/1/2020)

IGC CODE REFERENCE : Ch 4, 4.18.2.2

For each structural detail for which the fatigue analysis is to be carried out, the conventional cumulative damage is to be calculated according to the following procedure:

- the long-term value of hot spot stress range  $\Delta\sigma_{s,0}$  is to be obtained from the following formula:

$$\Delta\sigma_{s,0} = |\sigma_{s,\text{MAX}} - \sigma_{s,\text{MIN}}|$$

where:

$\sigma_{s,\text{MAX}}$ ,  $\sigma_{s,\text{MIN}}$ : Maximum and minimum hot spot stress to be obtained from a structural analysis carried out in accordance with Pt B, Ch 7, App 1, where the wave loads are those defined in [7.3.3]

- the long-term value of the notch stress range  $\Delta\sigma_{N,0}$  is obtained from the formulae in Pt B, Ch 7, Sec 4, [3.3] as a function of the hot spot stress range  $\Delta\sigma_{s,0}$
- the long-term distribution of notch stress ranges  $\Delta\sigma_{N,i}$  is to be calculated. Each stress range  $\Delta\sigma_{N,i}$  of the distribution, corresponding to  $n_i$  stress cycles, is obtained from the formulae in [7.3.4], where  $\sigma_0$  is taken equal to  $\Delta\sigma_{N,0}$ .
- For each notch stress range  $\Delta\sigma_{N,i}$ , the number of stress cycles  $N_i$  which cause the fatigue failure is to be obtained by means of S-N curves corresponding to the as-rolled condition (see Fig 6). The criteria adopted for obtaining the S-N curves are to be documented. Where this documentation is not available, the Society may require the curves to be obtained from experiments performed in accordance with recognised standards.
- The conventional cumulative damage for the  $i$  notch stress ranges  $\Delta\sigma_{N,i}$  is to be obtained from the formula in IGC Code 4.18.2.2.

**Figure 5 : Simplified stress distribution for fatigue analysis**

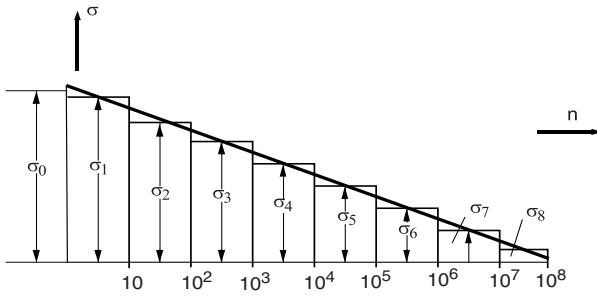

**Figure 6 : Fatigue check based on conventional cumulative damage method**

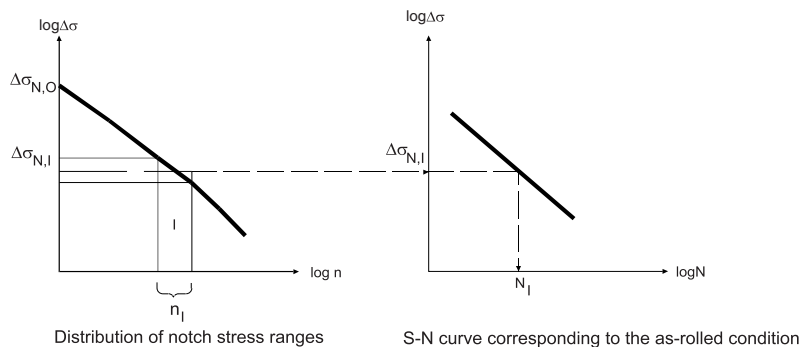

**7.3.6 Check criteria**

The conventional cumulative damage, to be calculated according to [7.3.5], is to be not greater than  $C_{W}$ , defined in IGC 4.4.5.6.

**7.4 Crack propagation analysis**

**7.4.1 General (1/1/2020)**

IGC CODE REFERENCE : Ch 4, 4.22

The crack propagation analysis is to be carried out for highly stressed areas. The latter are to be defined by the Designer and agreed by the Society on a case-by-case basis. Propagation rates in the parent material, weld metal and heat-affected zone are to be considered.

The following checks are to be carried out:

- crack propagation from an initial defect, in order to check that the defect will not grow and cause a brittle fracture before the defect is detected; this check is to be carried out according to [7.4.4]
- crack propagation from an initial through thickness defect, in order to check that the defect, resulting in a leakage, will not grow and cause a brittle fracture less than 15 days after its detection; this check is to be carried out according to [7.4.5].

**7.4.2 Material properties (1/1/2020)**

IGC CODE REFERENCE : Ch 4, 4.22

The material fracture mechanical properties used for the crack propagation analysis, i.e. the properties relating the

crack propagation rate to the stress intensity range at the crack tip, are to be documented for the various thicknesses of parent material and weld metal alike. Where this documentation is not available, the Society may request to obtain these properties from experiments performed in accordance with recognised standards.

**7.4.3 Simplified stress distribution for crack propagation analysis (1/1/2020)**

IGC CODE REFERENCE : Ch 4, 4.18.2.6.3

The simplified wave load distribution indicated in IGC Code 4.18.2.6.3 may be represented over a period of 15 days by means of 5 stress ranges, each characterised by an alternating stress  $\pm\sigma_i$  and number of cycles,  $n_i$  (see Fig 7). The corresponding values of  $\sigma_i$  and  $n_i$  are to be obtained from the following formulae:

$$\sigma_i = \sigma_0 \left( 1,1 - \frac{i}{5,3} \right)$$

$$n_i = 0,913 \cdot 10^i$$

where:

$\sigma_i$  : Stress ( $i = 1,06; 2,12; 3,18; 4,24; 5,30$ ), in N/mm<sup>2</sup>, (see Fig 7)

$\sigma_0$  : Defined in [7.3.4]

$n_i$  : Number of cycles for each stress  $\sigma_i$  considered ( $i = 1,06; 2,12; 3,18; 4,24; 5,30$ ).

**Figure 7 : Simplified stress distribution for crack propagation analysis**

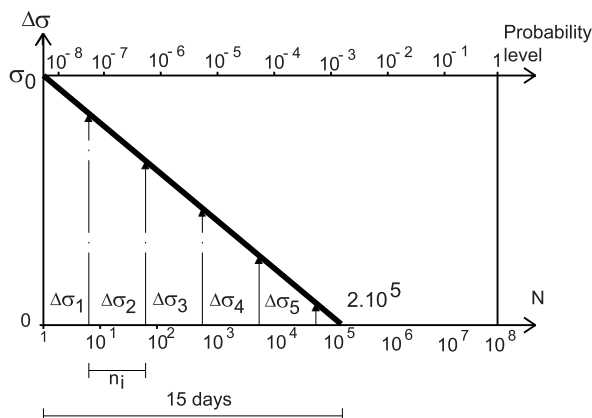

#### 7.4.4 Crack propagation analysis from an initial defect (1/1/2020)

IGC CODE REFERENCE : Ch 4, 4.22

It is to be checked that an initial crack will not grow, under wave loading based on the stress distribution in [7.3.4], beyond the allowable crack size.

The initial size and shape of the crack is to be considered by the Society on a case-by-case basis, taking into account the structural detail and the inspection method.

The allowable crack size is to be considered by the Society on a case-by-case basis; in any event, it is to be taken less than that which may lead to a loss of effectiveness of the structural element considered.

#### 7.4.5 Crack propagation analysis from an initial through thickness defect (1/1/2020)

IGC CODE REFERENCE : Ch 4, 4.22

It is to be checked that an initial through thickness crack will not grow, under dynamic loading based on the stress distribution in [7.4.3], beyond the allowable crack size.

The initial size of the through thickness crack is to be taken not less than that through which the minimum flow size that can be detected by the monitoring system (e.g. gas detectors) may pass.

The allowable crack size is to be considered by the Society on a case-by-case basis; in any event, it is to be taken far less than the critical crack length, defined in [7.4.6].

#### 7.4.6 Critical crack length (1/1/2020)

IGC CODE REFERENCE : Ch 4, 4.22

The critical crack length is the crack length from which a brittle fracture may initiate and it is to be considered by the Society on a case-by-case basis. In any event, it is to be evaluated for the most probable maximum stress experienced by the structural element in the ship life, which is equal to the stress in the considered detail obtained from the structural analysis to be performed in accordance with [7.2.1].

## 8 Structural analysis of type C independent tanks

### 8.1 Stiffening rings in way of tank supports

#### 8.1.1 Structural model (1/1/2020)

IGC CODE REFERENCE : Ch 4, 4.23

The stiffening rings in way of supports of horizontal cylindrical tanks are to be modelled as circumferential beams constituted by web, flange, doubler plate, if any, and plating attached to the stiffening rings.

#### 8.1.2 Width of attached plating (1/1/2020)

IGC CODE REFERENCE : Ch 4, 4.23

On each side of the web, the width of the attached plating to be considered for the yielding and buckling checks of the stiffening rings, as in [8.1.5] and [8.1.6], respectively, is to be obtained, in mm, from the following formulae:

- $b = 0,78 \sqrt{rt}$  for cylindrical shell,
- $b = 20 t_b$  for longitudinal bulkheads (in the case of lobe tanks)

where:

- $r$  : Mean radius, in mm, of the cylindrical shell
- $t$  : Shell thickness, in mm
- $t_b$  : Bulkhead thickness, in mm.

A doubler plate, if any, may be considered as belonging to the attached plating.

#### 8.1.3 Boundary conditions (1/1/2020)

IGC CODE REFERENCE : Ch 4, 4.23

The boundary conditions of the stiffening ring are to be modelled as follows:

- circumferential forces applied on each side of the ring, whose resultant is equal to the shear force in the tank and calculated through the bi-dimensional shear flow theory
- reaction forces in way of tank supports, to be obtained according to [9.2].

#### 8.1.4 Lateral pressure (1/1/2020)

IGC CODE REFERENCE : Ch 4, 4.23

The lateral pressure to be considered for the check of the stiffening rings is to be obtained from [2.2].

#### 8.1.5 Yielding check (1/1/2020)

IGC CODE REFERENCE : Ch 4, 4.23

The equivalent stress in stiffening rings in way of supports is to comply with the following formula:

$$\sigma_E \leq \sigma_{ALL}$$

where:

- $\sigma_E$  : Equivalent stress in stiffening rings calculated for the load cases defined in IGC 4.13.9 and IGC 4.14.1, in N/mm<sup>2</sup>, and to be obtained from the following formula:

$$\sigma_E = \sqrt{(\sigma_N + \sigma_B) + 3\tau^2}$$

- $\sigma_N$  : Normal stress, in N/mm<sup>2</sup>, in the circumferential direction of the stiffening ring
- $\sigma_B$  : Bending stress, in N/mm<sup>2</sup>, in the circumferential direction of the stiffening ring
- $\tau$  : Shear stress, in N/mm<sup>2</sup>, in the stiffening ring
- $\sigma_{ALL}$  : Allowable stress, in N/mm<sup>2</sup>, to be taken equal to the lesser of the following values:
- 0,57  $R_m$
  - 0,85  $R_{eH}$
- $R_m$  : Defined in Pt B, Ch 4, Sec 1, [2.1]
- $R_{eH}$  : Defined in Pt B, Ch 4, Sec 1, [2.1].

### 8.1.6 Buckling check (1/1/2020)

IGC CODE REFERENCE : Ch 4, 4.23

The buckling strength of the stiffening rings is to be checked in compliance with the applicable formulae in Pt B, Ch 7, Sec 2.

## 9 Supports

### 9.1 Structural arrangement

#### 9.1.1 General (1/1/2020)

REFERENCE IGC CODE : Ch 4, 4.8

The reaction forces in way of tank supports are to be transmitted as directly as possible to the hull primary supporting members, minimising stress concentrations.

Where the reaction forces are not in the plane of primary members, web plates and brackets are to be provided in order to transmit these loads by means of shear stresses.

#### 9.1.2 Structure continuity

Special attention is to be paid to continuity of structure between circular tank supports and the primary supporting members of the ship.

#### 9.1.3 Openings (1/1/2020)

IGC CODE REFERENCE : Ch 4, 4.8

In primary supporting members of tank supports and hull structures in way of tank supports which constitute hull supports, openings are to be avoided and local strengthening may be necessary.

#### 9.1.4 Antiflotation arrangements (1/1/2020)

IGC CODE REFERENCE : Ch 4, 4.8.2

Adequate clearance between the tanks and the hull structures is to be provided in all operating conditions.

### 9.2 Calculation of reaction forces in way of tank supports

#### 9.2.1 (1/1/2020)

IGC CODE REFERENCE : Ch 4, 4.8

The reaction forces in way of tank supports are to be obtained from the structural analysis of the tank or stiffening

rings in way of tank supports, considering the loads specified in:

- [6], for the structural analysis of type A independent tanks
- [7], for the structural analysis of type B independent tanks
- [8], for the structural analysis of type C independent tanks.

The final distribution of the reaction forces at the supports is not to show any tensile forces.

### 9.3 Keys

#### 9.3.1 General

Fillings lower than 90% are generally not admitted for tanks having no upper rolling keys.

The structure of the tank and of the ship is to be reinforced in way of the keys so as to support the reactions and the corresponding moments.

#### 9.3.2 Rolling keys

Rolling keys are to be checked under transverse and vertical accelerations, defined in Pt B, Ch 5, Sec 3, [3.4.1] for the inclined ship conditions, and applied on the maximum weight of the full tank.

It is to be checked that the combined stress in rolling keys is in compliance with the following formula:

$$\sigma_{ALL} > \sigma_C$$

where:

$\sigma_{ALL}$  : Allowable stress, N/mm<sup>2</sup>, to be taken equal to the minimum of 0,75  $R_{eH}$  and 0,5  $R_m$

$R_{eH}$  : Yield stress, in N/mm<sup>2</sup>, of the steel used, at 20°C

$R_m$  : Minimum ultimate tensile strength, in N/mm<sup>2</sup>, at 20°C.

#### 9.3.3 Pitching keys

Pitching keys are to be checked under longitudinal accelerations, to be taken not less than 0,3, and vertical accelerations, defined in Pt B, Ch 5, Sec 3, [3.4.1] for the upright conditions, and applied on the maximum weight of the full tank.

It is to be checked that the combined stress in pitching keys is in compliance with the following formula:

$$\sigma_{ALL} > \sigma_C$$

where:

$\sigma_{ALL}$  : Allowable stress, N/mm<sup>2</sup>, defined in [9.3.2].

### 9.4 Scantlings of type C independent tank supports and hull structures in way

#### 9.4.1 (1/1/2020)

IGC CODE REFERENCE : Ch 4, 4.8

The net scantlings of plating, ordinary stiffeners and primary supporting members of tank supports and hull structures in way are to be not less than those obtained by applying the criteria in Part B, Chapter 7.

The hull girder loads and the lateral pressure to be considered in the formulae above are to be obtained from the formulae in Part B, Chapter 5.

The values of reaction forces in way of tank supports to be considered for the scantlings of these structural elements are to be obtained from a structural analysis of the tank (see [9.2]) in which the ship accelerations defined in [2.2] are multiplied by 0,625.

## 10 Secondary barrier

### 10.1 Secondary barrier extent

#### 10.1.1 (1/1/2020)

IGC CODE REFERENCE : Ch 4, 4.6

The extent of the secondary barrier is to be not less than that necessary to protect the hull structures assuming that the cargo tank is breached at a static angle of heel of 30°, with an equalisation of the liquid cargo in the tank (see Fig 8).

**Figure 8 : Secondary barrier extension**

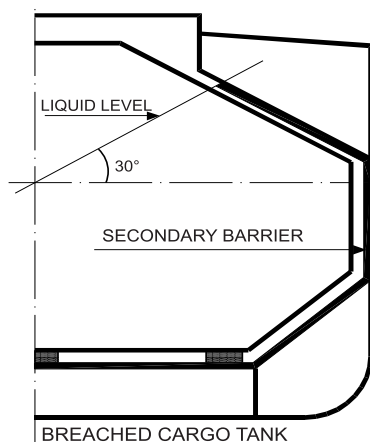

#### 10.1.2 (1/1/2020)

IGC CODE REFERENCE : Ch 4, 4.6.2.4 and 4.7.7

For containment systems with glued secondary barriers:

- At the time of construction, a tightness test should be carried out in accordance with approved system designers' procedures and acceptance criteria before and after initial cool down. Low differential pressures tests are not considered an acceptable test.
- If the designer's threshold values are exceeded, an investigation is to be carried out and additional testing such as thermographic or acoustic emissions testing should be carried out.
- The values recorded should be used as reference for future assessment of secondary barrier tightness.

For containment systems with welded metallic secondary barriers, a tightness test after initial cool down is not required.

## 11 Insulation

### 11.1 Heating of structures

#### 11.1.1 Segregation of heating plant (1/1/2020)

IGC CODE REFERENCE : Ch 4, 4.19.1.6

Where a hull heating system complying with IGC 4.19.1.6 is installed, this system is to be contained solely within the cargo area or the drain returns from the hull heating coils in the wing tanks, cofferdams and double bottom are to be led to a degassing tank. The degassing tank is to be located in the cargo area and the vent outlets are to be located in a safe position and fitted with a flame screen.

#### 11.1.2 Temperature of steam and heating media within the cargo area (1/1/2020)

IGC CODE REFERENCE : Ch 4, 4.19.1.6

The maximum temperature of steam and heating media within the cargo area is to be adjusted to take into account the temperature class of the cargoes.

## 12 Materials

### 12.1 Insulation material characteristics

#### 12.1.1 (1/1/2020)

IGC CODE REFERENCE : Ch 4, 4.19.3.1 and 4.19.3.4

The materials for insulation are to be approved by the Society.

The approval of bonding materials, sealing materials, lining constituting a vapour barrier or mechanical protection is to be considered by the Society on a case-by-case basis. In any event, these materials are to be chemically compatible with the insulation material.

#### 12.1.2 (1/1/2020)

IGC CODE REFERENCE : Ch 4, 4.19.3.1 and 4.19.3.4

Before applying the insulation, the surfaces of the tank structures or of the hull are to be carefully cleaned.

#### 12.1.3 (1/1/2020)

IGC CODE REFERENCE : Ch 4, 4.19.3.1 and 4.19.3.4

Where applicable, the insulation system is to be suitable to be visually examined at least on one side.

#### 12.1.4 (1/1/2020)

IGC CODE REFERENCE : Ch 4, 4.19.3.1 and 4.19.3.4

When the insulation is sprayed or foamed, the minimum steel temperature at the time of application is to be not less than the temperature given in the specification of the insulation.

## 13 Construction and testing

### 13.1 Weld joint design

#### 13.1.1 (1/1/2020)

IGC CODE REFERENCE: Ch 4, 4.20.1.1

For tee welds in type A or type B independent tanks, the wording "for dome-to-shell connections only" is to be interpreted to mean as follows:

- Welded corners (i.e. corners made of weld metal) shall not be used in the main tank shell construction, i.e. corners between shell side (sloped plane surfaces parallel to hopper or top side inclusive if any) and bottom or top of the tank, and between tank end transverse bulkheads and bottom, top or shell sides (sloped plane surfaces inclusive if any) of the tank. Instead, tank corners which are constructed using bent plating aligned with the tank surfaces and connected with in-plane welds are to be used.
- Tee welds can be accepted for other localized constructions of the shell such as suction well, sump, dome, etc. where tee welds of full penetration type shall also be used.

**13.1.2 (1/1/2020)**

IGC CODE REFERENCE : Ch 4, 4.20.1.2

For welds of type C independent bi-lobe tank with centerline bulkhead, the wording "Other edge preparations" is to be interpreted to mean as follows:

Cruciform full penetration welded joints in a bi-lobe tank with centreline bulkhead can be accepted for the tank structure construction at tank centreline welds with bevel preparation subject to the approval of the Administration or recognised organization acting on its behalf, based on the results of the tests carried out at the approval of the welding procedure. (See below example)

**Figure 9 : (1/1/2020)**

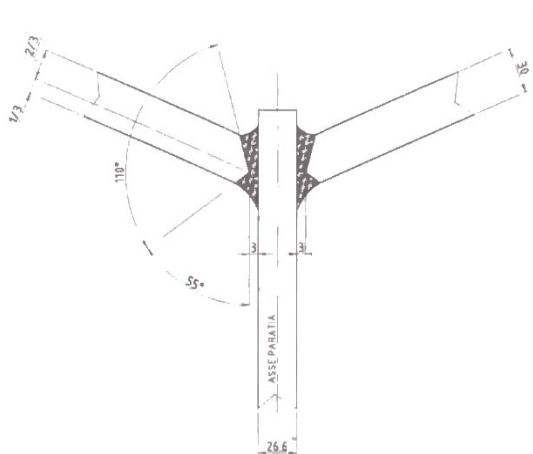

**13.2 Integral tank testing**

**13.2.1 (1/1/2020)**

IGC CODE REFERENCE: Ch 4, 4.10.625.5

The testing of integral tanks is to comply with the requirements in Pt B, Ch 12, Sec 3.

**13.3 Membrane and semi-membrane tanks testing**

**13.3.1 (1/1/2020)**

IGC CODE REFERENCE : Ch 4, 4.24.9.1

The testing of membrane and semi-membrane tanks is to comply with the requirements in Pt B, Ch 12, Sec 3.

**13.4 Independent tank testing**

**13.4.1 (1/1/2020)**

IGC CODE REFERENCE : Ch 4, 4.21.5, 4.22.6, 4.23.6

The conditions in which testing is performed are to simulate as far as possible the actual loading on the tank and its supports.

**13.4.2 (1/1/2020)**

IGC CODE REFERENCE : Ch 4, 4.21.5, 4.22.6, 4.23.6

When testing takes place after installation of the cargo tank, provision is to be made prior to the launching of the ship in order to avoid excessive stresses in the ship structures.

**13.5 Final tests**

**13.5.1 (1/1/2020)**

IGC CODE REFERENCE : Ch 4, 4.20.3

The tests on the completed system are to be performed in the presence of a Surveyor and are to demonstrate that the cargo containment arrangements are capable of being inerted, cooled, loaded and unloaded in a satisfactory way and that all the safety devices operate correctly.

**13.5.2 (1/1/2020)**

IGC CODE REFERENCE : Ch 4, 4.20.3

Tests are to be performed at the minimum service temperature or at a temperature very close to it.

**13.5.3 (1/1/2020)**

IGC CODE REFERENCE : Ch 4, 4.20.3

The reliquefaction and inert gas production systems, if any, and the installation, if any, for use of gas as fuel for boilers and internal combustion engines are also to be tested to the satisfaction of the Surveyor.

**13.5.4 (1/1/2020)**

IGC CODE REFERENCE : Ch 4, 4.20.3

All operating data and temperatures read during the first voyage of the loaded ship are to be sent to the Society.

**13.5.5 (1/1/2020)**

IGC CODE REFERENCE : Ch 4, 4.20.3

All data and temperatures read during subsequent voyages are to be kept at the disposal of the Society for a suitable period of time.

**14 Structural details**

**14.1 Special structural details**

**14.1.1** The specific requirements in Pt B, Ch 12, Sec 2, [2.4] for ships with the service notation **liquefied gas carrier** are to be complied with.

## 14.2 Connections of the inner hull plating with intermediate plating

### 14.2.1 (1/1/2020)

IGC CODE REFERENCE : Ch 4, 4.20

The connections of the inner hull plating with intermediate plating are to be made according to:

- sheets 4.5 to 4.7 in Pt B, Ch 12, App 1 for position 1 in Fig 10
- sheets 6.8 and 6.9 in Pt B, Ch 12, App 1 for position 2 in Fig 10
- for positions 3 and 4 in Fig 10 in a similar way to positions 1 and 2.

**Figure 10 : Positions of connections**

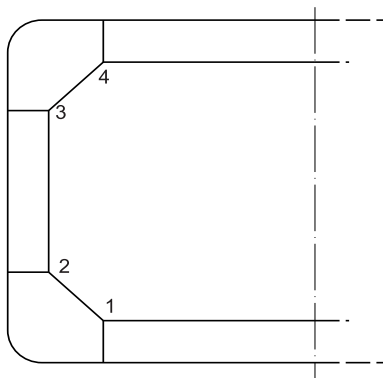

**14.2.2** Where there is no prolonging bracket in way of knuckle joints in positions 1 and/or 2, the connection of transverse webs to the inner hull and longitudinal girder plating is to be made with partial penetration welds over a length not less than 400 mm.

## 14.3 Connections of inner bottom with transverse cofferdam bulkheads

### 14.3.1 General

In addition to sheet 3.5 in Pt B, Ch 12, App 1, the requirements in [14.3.2] to [14.3.4] apply.

### 14.3.2 Floors (1/1/2020)

IGC CODE REFERENCE : Ch 4, 4.20

The thickness and material properties of the supporting floors are to be at least equal to those of the cofferdam bulkhead plating.

### 14.3.3 Vertical webs within cofferdam bulkhead (1/1/2020)

IGC CODE REFERENCE : Ch 4, 4.20

Vertical webs fitted within the cofferdam bulkhead are to be aligned with the double bottom girders.

### 14.3.4 Manholes

IGC CODE REFERENCE : Ch 4, 4.20

Manholes in double bottom floors aligned with the cofferdam bulkhead plating are to be located as low as practicable and at mid-distance between two adjacent longitudinal girders.

## 14.4 Cut-outs and connections

### 14.4.1 Cut-outs (1/1/2020)

IGC CODE REFERENCE : Ch 4, 4.20

Cut-outs for the passage of inner hull and cofferdam bulkhead ordinary stiffeners through the vertical webs are to be closed by collar plates welded to the inner hull plating.

### 14.4.2 Connection of the cargo containment system to the hull structure (1/1/2020)

IGC CODE REFERENCE : Ch 4, 4.20

Where deemed necessary, adequate reinforcements are to be fitted in the double hull and transverse cofferdams at connection of the cargo containment system to the hull structure. Details of the connection are to be submitted to the Society for approval.

## SECTION 5

# PROCESS PRESSURE VESSELS AND LIQUID, VAPOUR AND PRESSURE PIPING SYSTEMS

## 1 General

### 1.1 Process pressure vessels

#### 1.1.1

IGC CODE REFERENCE : Ch 5, 5.1.2

Process pressure vessels handling cargo are to be considered at least as class 2 pressure vessels, in accordance with Pt C, Ch 1, Sec 3, [1.4.1].

#### 1.1.2 Temperature of steam and heating media within the cargo area (1/7/2007)

IGC CODE REFERENCE : Ch 5, 5.1

The maximum temperature of steam and heating media within the cargo area is to be adjusted to take into account the temperature class of the cargoes.

## 2 Cargo and process piping

### 2.1 General

#### 2.1.1 (1/1/2023)

Cargo pipes, including single wall pipes and inner pipes of double wall arrangements, belong to Class I piping systems, as defined in Pt C, Ch 1, Sec 10, [1.5].

Outer pipes of double wall cargo piping arrangements belong to Class II piping systems, as defined in Pt C, Ch 1, Sec 10, [1.5].

#### 2.1.2 Provisions for protection of piping against thermal stress (1/1/2021)

IGC CODE REFERENCE : Ch 5, 5.7.1, 5.11.6.4

Expansion joints are to be protected from extensions and compressions greater than the limits fixed for them and the connected piping is to be suitably supported and anchored. Bellow expansion joints are to be protected from mechanical damage.

The design and installation of expansion bellows is to be in accordance with recognized standards acceptable to the Society.

#### 2.1.3 Segregation of high temperature piping (1/1/2020)

IGC CODE REFERENCE : Ch 5, 5.7.2

High temperature pipes are to be thermally isolated from the adjacent structures. In particular, the temperature of pipelines is not to exceed 220 °C in gas-dangerous zones.

#### 2.1.4 Pressure relief valve setting (1/1/2020)

IGC CODE REFERENCE : Ch 5, 5.5.6 and 5.5.7

Pressure relief valves are to be set to discharge at a pressure not greater than the design pressure such that the overpressure during discharge does not exceed 110% of the design pressure.

#### 2.1.5 Protection against leakage (1/1/2020)

IGC CODE REFERENCE : Ch 5, 5.2

Where the piping system is intended for liquids having a boiling point lower than - 30 °C, permanent means to avoid possibility of contact between leaks and hull structures are to be provided in all those locations where leakage might be expected, such as shore connections, pump seals, flanges subject to frequent dismantling, etc.

#### 2.1.6 Means for detecting the presence of liquid cargo (1/1/2020)

IGC CODE REFERENCE : Ch 5, 5.2

The means to detect the presence of liquid cargo may be constituted by electrical level switches whose circuit is intrinsically safe. The alarm signals given by the level switches are to be transmitted to the wheelhouse and to the cargo control station, if provided.

#### 2.1.7 Connections of relief valve discharges to cargo tanks (1/1/2020)

IGC CODE REFERENCE : Ch 5, 5.2

The connections, if any, to the cargo tanks of relief valve discharges fitted on the liquid phase cargo piping are not to be fitted with shut-off valves, but are to be provided with non-return valves in the proximity of the tanks.

#### 2.1.8 Centrifugal pumps (1/1/2020)

IGC CODE REFERENCE : Ch 5, 5.2

Overpressure relief valves on cargo pumps may be omitted in the case of centrifugal pumps having a maximum delivery head, the delivery valve being completely closed, not greater than that permitted for the piping.

## 2.2 Scantlings based on internal pressure

### 2.2.1 Piping scantlings (1/1/2021)

IGC CODE REFERENCE : Ch 5, 5.11.2.2, 5.11.2.4 and 5.11.4

Piping systems are to be designed in accordance with recognized standards acceptable to the Society.

The minimum thickness is to be in accordance with recognized standards acceptable to the Society.

### 2.2.2 Piping subject to green seas (1/1/2020)

IGC CODE REFERENCE : Ch 5, 5.11.2.2



In particular for piping subject to green seas, the design pressure  $P$ , in bar, in the formula in 5.11.2.2 of the IGC CODE is to be replaced by an equivalent pressure  $P'$  given by the following formula:

$$P' = \frac{1}{2} \left( P + \sqrt{P^2 + 0,006 R' K \frac{D_c}{D}} \right)$$

where:

$D_c$  : External diameter of the pipe taking into account the insulation (in mm), whose thickness is to be taken at least equal to:

40 mm if  $D \leq 50$  mm

80 mm if  $D \geq 150$  mm

Intermediate values are to be determined by interpolation.

$R'$  : Drag corresponding to the effect of green seas, in da N/m<sup>2</sup>, such as given in Tab 1 as a function of the location of the pipes and of their height  $H$  (in m) above the deepest loadline; intermediate values are to be determined by interpolation.

$K$  : permissible stress, in N/mm<sup>2</sup>

**Table 1**

External diameter of pipe (1)	Aft of the quarter of the ship's length			Forward of the quarter of the ship's length		
	$H \leq 8$	$H = 13$	$H \geq 18$	$H \leq 8$	$H = 13$	$H \geq 18$
$\leq 25$	1500	250	150	2200	350	150
50	1400	250	150	2000	350	150
75	1100	250	150	1600	350	150
100	700	250	150	700	350	150
$\geq 150$	500	250	150	700	350	150

(1)  $D_c$  if the pipe is insulated,  $D$  otherwise.

## 2.3 Design pressure

### 2.3.1 Design pressure definition (1/1/2021)

IGC CODE REFERENCE : Ch 5, 5.4.1

For each piping section, the maximum pressure value among those applicable in paragraph 5.11.2.2 of the IGC Code is to be considered.

Higher or lower values of the saturated and superheated vapour pressure at 45°C may be used if agreed upon by the Society.

## 2.4 Permissible stress

### 2.4.1 Flanges, valves and fittings (1/1/2021)

IGC CODE REFERENCE : Ch 5, 5.11.6.1, 5.11.6.2

For flanges not complying with a standard, the dimensions and type of gaskets are to be to the satisfaction of the Society.

Flanges are to be selected as to type, made and tested in accordance with the Pt C, Ch 1, Sec 10.

## 2.5 Stress analysis

### 2.5.1 Calculations in accordance with recognised standards (1/1/2020)

IGC CODE REFERENCE : Ch 5, 5.11.5

When such an analysis is required, it is to be carried out in accordance with the requirements listed below. Subject to this condition, calculations in accordance with recognised standards are admitted by the Society.

### 2.5.2 Calculation cases (1/1/2020)

IGC CODE REFERENCE : Ch 5, 5.11.5

The calculations are to be made for every possible case of operation, but only those leading to the most unfavourable results are required to be submitted.

### 2.5.3 Loads to be taken for calculation (1/1/2021)

IGC CODE REFERENCE : Ch 5, 5.11.5

The calculations are to be carried out taking into account the following loads:

- a) piping not subject to green seas:
  - pressure
  - weight of the piping with insulation and internal medium
  - contraction
- b) piping subject to green seas that is liable to be in operation at sea and in port:
  - pressure
  - weight of the piping with insulation and internal medium
  - green seas
  - contraction
  - ship motion accelerations
- c) piping subject to green seas that is in operation only in port; the more severe of the following two combinations of loads:
  - pressure
  - weight of the piping with insulation and internal medium
  - contraction
 and
  - weight of the piping
  - green seas

- expansion, assuming that the thermal stresses are fully relaxed.

#### 2.5.4 Green sea directions (1/1/2020)

IGC CODE REFERENCE : Ch 5, 5.11.5

When green seas are considered, their effects are to be studied, unless otherwise justified, in the following three directions:

- axis of the ship
- vertical
- horizontal, perpendicular to the axis of the ship. The load on the pipes is the load  $R'$  defined in [2.2.2].

#### 2.5.5 Stress intensity (1/1/2020)

IGC CODE REFERENCE : Ch 5, 5.11.5

The stress intensity is to be determined as specified in the formulae in Pt C, Ch 1, Sec 10, [2.3.2] for pipes intended for high temperatures:

- a) for primary stresses resulting from:
  - pressure
  - weight
  - green seas
- b) for primary stresses and secondary stresses resulting from contraction.

#### 2.5.6 Stress intensity limits (1/1/2020)

IGC CODE REFERENCE : Ch 5, 5.11.5

- a) For the first case, the stress intensity is to be limited to the lower of:  
 $0,8 R_e$  and  $0,4 R_m$
- b) For the second case, the stress intensity is to be limited to the lower of:  
 $1,6 R_e$  and  $0,8 R_m$ .

#### 2.5.7 Piping with expansion devices (1/1/2020)

IGC CODE REFERENCE : Ch 5, 5.11.5

For piping fitted with expansion devices, their characteristics are to be submitted to the Society. Where these characteristics are such that the forces and moments at the ends of the devices are negligible for the contraction they must absorb, the calculation of the loads due to contraction in the corresponding piping is not required. It is, however, to be checked that the stress intensity corresponding to the primary stresses does not exceed the limits given in [2.5.6].

#### 2.5.8 Flexibility coefficient (1/1/2020)

IGC CODE REFERENCE : Ch 5, 5.11.5

The flexibility coefficient of elbows is to be determined from the formulae given in Pt C, Ch 1, Sec 10, [2.3.2] for pipes intended for high temperatures.

#### 2.5.9 Local stresses (1/1/2020)

IGC CODE REFERENCE : Ch 5, 5.11.5

Particular attention is to be paid to the calculation of local stresses in the assemblies subjected to axial forces and bending moments. The Society reserves the right to request additional justifications or local strengthening where considered necessary.

## 2.6 Materials

### 2.6.1 (1/1/2023)

IGC CODE REFERENCE : Ch 5, 5.12

Aluminised pipes may be fitted in ballast tanks, in inerted cargo tanks and, provided the pipes are protected from accidental impact, in hazardous areas on open deck.

For an outer pipe or duct equipped with mechanical exhaust ventilation having a capacity of at least 30 air changes per hour, the effects of both pressure and possible low temperature in the event of a high pressure line failure shall be taking into account.

Tests for materials are required for all cargo pipes belonging to Class I irrespective of their diameter.

Materials of outer pipes belonging to Class II are to be tested according to the Pt C, Ch 1, Sec 10, Tab 35.

## 2.7 Piping fabrication and joining details

### 2.7.1 (1/1/2021)

IGC CODE REFERENCE : Ch 5, 5.8

The Society may accept relaxations, based on recognized standards, from the requirements in IGC Code, 5.8 for piping inside cargo tanks and open ended piping.

Acceptance of types of piping connections other than those mentioned in IGC Code, 5.8 may be considered by the Society case by case.

## 2.8 Welding, post-weld heat treatment and non-destructive testing

### 2.8.1 (1/1/2023)

IGC CODE REFERENCE : Ch 5, 5.9

For post-weld heat treatments, the Society may waive the requirement for thermal stress relieving for pipes having a wall thickness less than 10 mm in relation to the design temperature and pressure of the concerned piping system.

For outer pipes of double wall cargo piping arrangements non-destructive testing are to be carried out according to IGC Code 5.9.3.

For butt-welded joints of pipes not covered by IGC Code 5.9.3.2 spot radiographic controls or other non-destructive controls are to be carried out at the discretion of the Society depending upon service, position and materials.

## 3 Tests of piping components and pumps prior to installation on board

### 3.1 Valves

#### 3.1.1 Prototype Testing (1/1/2021)

IGC CODE REFERENCE : Ch 5, 5.13

For safety valves that are subject to IGC Code para. 8.2.5, the flow or capacity are to be certified by the Society; for other types of valves, the manufacturer is to certify the flow properties of the valves based on tests carried out according to recognized standards.

For emergency shutdown valves, with materials having melting temperatures lower than 925°C, the type testing

shall include a fire test to a standard acceptable to the Society.

### 3.1.2 Unit Production Testing (1/1/2020)

IGC CODE REFERENCE: Ch 5, 5.13

All valves are to be tested at the Manufacturer's plant in the presence of the Society's Surveyor.

Testing is to include a hydrostatic test of the valve body at a pressure equal to 1,5 times the design pressure for all valves, seat and stem leakage test at a pressure equal to 1,1 times the design pressure for valves other than safety valves. In addition, cryogenic testing consisting of valve operation and leakage verification for a minimum of 10% of each type and size of valve for valves other than safety valves intended to be used at a working temperature below -55°C. The set pressure of safety valves is to be tested at ambient temperature.

For valves used for isolation of instrumentation in piping not greater than 25 mm, unit production testing need not be witnessed by the surveyor. Records of testing are to be available for review.

As an alternative to the above, if so requested by the relevant Manufacturer, certification of a valve may be issued subject to the following:

- the valve has been approved as required by [3.1.1] for valves intended to be used at a working temperature below -55°C, and
- the Manufacturer has a recognised quality system that has been assessed and certified by the Society subject to periodical audits, and
- the quality control plan contains a provision to subject each valve to a hydrostatic test of the valve body at a pressure equal to 1,5 times the design pressure for all valves and seat and stem leakage test at a pressure equal to 1,1 times the design pressure for valves other than safety valves. The set pressure of safety valves is to be tested at ambient temperature. The Manufacturer is to maintain records of such tests, and
- cryogenic testing is performed, in the presence of the Society's representative, consisting of valve operation and leakage verification for a minimum of 10% of each type and size of valve for valves other than safety valves intended to be used at a working temperature below -55°C.

## 3.2 Cargo Pumps

### 3.2.1 Prototype Testing (1/1/2012)

Each size and type of pump is to be approved through design assessment and prototype testing. Prototype testing is to be witnessed in the presence of the Society's Surveyor. In lieu of prototype testing, satisfactory in-service experience of an existing pump design approved by a QSCS Classification Society submitted by the Manufacturer may be considered.

Prototype testing is to include a hydrostatic test of the pump body equal to 1,5 times the design pressure and a capacity test. For submerged electric motor driven pumps, the capacity test is to be carried out with the design medium or with a medium below the minimum working temperature.

For shaft driven deep well pumps, the capacity test may be carried out with water. In addition, for shaft driven deep well pumps, a spin test to demonstrate satisfactory operation of bearing clearances, wear rings and sealing arrangements is to be carried out at the minimum design temperature. The full length of shafting is not required for the spin test, but must be of sufficient length to include at least one bearing and sealing arrangements. After completion of tests, the pump is to be opened out for examination.

### 3.2.2 Unit Production Testing (1/1/2012)

All pumps are to be tested at the Manufacturer's plant in the presence of the Society's Surveyor. Testing is to include a hydrostatic test of the pump body equal to 1,5 times the design pressure and a capacity test. For submerged electric motor driven pumps, the capacity test is to be carried out with the design medium or with a medium below the minimum working temperature. For shaft driven deep well pumps, the capacity test may be carried out with water.

As an alternative to the above, if so requested by the relevant Manufacturer, the certification of a pump may be issued subject to the following:

- the pump has been approved as required by [3.2.1] and
- the Manufacturer has a recognised quality system that has been assessed and certified by the Society subject to periodical audits, and
- the quality control plan contains a provision to subject each pump to a hydrostatic test of the pump body equal to 1,5 times the design pressure and a capacity test. The Manufacturer is to maintain records of such tests.

## 4 Cargo system valving requirements

### 4.1 Cargo tank connections for gauging

#### 4.1.1 Exemption (1/1/2020)

IGC CODE REFERENCE : Ch 5, 5.5.5

The requirements in paragraph 5.5.5 of the IGC Code relevant to cargo tank connections for pressure gauges and measuring devices do not apply to tanks with an MARVS not exceeding 0,07 MPa.

### 4.2 Emergency shutdown

#### 4.2.1 Clarification on location of fusible elements (1/1/2020)

IGC CODE REFERENCE : Ch 18, 18.10

The cargo stations in way of which the fusible elements mentioned in paragraph 18.10.3.2 of the IGC Code are to be fitted are to be intended as the loading and unloading manifolds.

#### 4.2.2 Fail-close action of Emergency Shut Down (ESD) valve (1/1/2024)

IGC CODE REFERENCE : Ch 18, 18.10.2.1.2

The following requirements specify the arrangements for emergency shut down valve (hereinafter referred to as ESD valve) installed in cargo piping of ships engaged in the carriage of liquefied gases to stop cargo flow in the event of

an emergency, either internally within the ship, or during cargo transfer to other ships or shore facilities.

When ESD valve is actuated by hydraulic or pneumatic system, the following are to be complied with:

- a) audible and visible alarm is to be given in the event of loss of pressure that causes activation of fail-close action. The alarm is to be provided in a normally manned control station (e.g. Cargo Control Room and/or the navigation bridge, etc.).
- b) the following conditions are also to be complied to ensure the fail-close action:
  - 1) failure of hydraulic or pneumatic system is not to lead to loss of fail-close functionality (i.e. activated by spring or weight); or
  - 2) hydraulic or pneumatic system for fail-close action is to be arranged with stored power and separated from normal valve operation.

## 5 Cargo transfer methods

### 5.1 Discharge into common header

#### 5.1.1 (1/1/2020)

IGC CODE REFERENCE : Ch 5, 5.6

When two or more pumps located in different cargo tanks are operating at the same time discharging into a common header, the stopping of the pumps is to activate an alarm at the centralised cargo control location.

## 6 Bonding

### 6.1 Static electricity

#### 6.1.1 Acceptable resistance (1/1/2020)

IGC CODE REFERENCE : Ch 5, 5.7.4

To avoid the hazard of an incentive discharge due to the build-up of static electricity resulting from the flow of the

liquid/gases/vapours, the resistance between any point on the surface of the cargo and slop tanks, piping systems and equipment, and the hull of the ship is not to be greater than  $10^6 \Omega$ .

#### 6.1.2 Bonding straps (1/1/2020)

IGC CODE REFERENCE : Ch 5, 5.7.4

Bonding straps are required for cargo and slop tanks, piping systems and equipment which are not permanently connected to the hull of the ship, for example:

- a) independent cargo tanks
- b) cargo tank piping systems which are electrically separated from the hull of the ship
- c) pipe connections arranged for the removal of the spool pieces.

Where bonding straps are required, they are to be:

- a) clearly visible so that any shortcoming can be clearly detected
- b) designed and sited so that they are protected against mechanical damage and are not affected by high resistivity contamination, e.g. corrosive products or paint
- c) easy to install and replace.

## 7 Integrated cargo and ballast system

### 7.1 General

#### 7.1.1 (1/1/2004)

The requirements for integrated cargo and ballast systems are given in Ch 7, Sec 4, [3.5].

## SECTION 6

## MATERIALS FOR CONSTRUCTION

### 1 Material requirements

#### 1.1 Tubes, forgings and castings for cargo and process piping

1.1.1 (1/7/2022)

IGC CODE REFERENCE: Ch 6, Tables 6.1, 6.2 and 6.3

The requirements in Pt D, Ch 2, App 7 apply.

1.1.2 (1/4/2009)

IGC CODE REFERENCE: Ch 6, Table 6.4

In general, impact tests for forgings, castings and welded and seamless pipes in stainless austenitic grades 304, 304L, 316, 316L, 321 and 347 are required when the design temperature is below -105°C and are to be carried out at -196°C.

#### 1.2 Aluminium coatings

1.2.1 (1/1/2020)

IGC CODE REFERENCE : Ch 6, 6.4

The use of aluminium coatings containing more than 10% aluminium by weight in the dry film is prohibited in the cargo tanks, cargo tank deck area, pump rooms, cofferdams or any other area where cargo gas may accumulate.

### 2 Welding and non-destructive testing

#### 2.1 Welding consumables

2.1.1 (1/1/2020)

IGC CODE REFERENCE : Ch 6, 6.5.2.1

The content of paragraph 6.5.2.1 of the IGC Code is also to cover process pressure vessels and secondary barriers.

#### 2.2 Test requirements

2.2.1 Bend tests (1/1/2020)

IGC CODE REFERENCE : Ch 6, 6.5.3.5.2

As an alternative to the bend test indicated in paragraph 6.5.3.5.2 of the IGC Code, a test over a mandrel having a diameter equal to 3 times the thickness with a bend angle up to 120° may be required.

### 3 Steels for hull structure

#### 3.1 Grades of steel

3.1.1 (1/7/2014)

In addition to the requirements specified in Pt B, Ch 4, Sec 1, [2.4], the material grade or class as specified in Tab 1 and Tab 2 apply to the hull structure steels of membrane type liquefied gas carriers.

The material grade requirements for hull members of each class, depending on the thickness, are defined in Pt B, Ch 4, Sec 1, Tab 7.

**Table 1 : Material classes applicable to membrane type liquefied gas carriers of any length (1/7/2014)**

Structural member category	Material class/grade
Trunk deck and inner deck plating at corners of openings for liquid and gas domes in membrane type liquefied gas carriers	<ul style="list-style-type: none"> <li>Class III within 0,6L amidships</li> <li>Class II within rest of cargo region</li> </ul>

**Table 2 : Minimum Material grades for membrane type liquefied gas carriers with length exceeding 150 m (1/7/2014)**

Structural member category	Material class/grade
Longitudinal plating of strength deck where contributing to the longitudinal strength	Grade B/AH within 0,4L amidships
Continuous longitudinal plating of strength members above the strength deck: Trunk deck plating	Class II within 0,4L amidships
Continuous longitudinal plating of strength members above the strength deck: <ul style="list-style-type: none"> <li>Inner deck plating</li> <li>Longitudinal strength member plating between the trunk deck and inner deck</li> </ul>	Grade B/AH within 0,4L amidships

**Note 1:** Tab 2 is applicable to membrane type liquefied gas carriers with deck arrangements as shown in Fig 1. Tab 2 may apply to similar ship types with a "double deck" arrangement above the strength deck.

Figure 1 : Typical deck arrangement for membrane type Liquefied Natural Gas Carriers (1/7/2014)

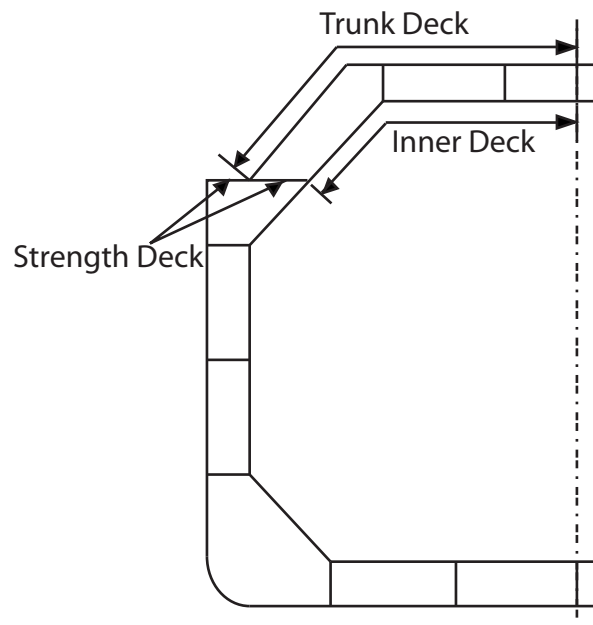

## SECTION 7

## CARGO PRESSURE/TEMPERATURE CONTROL

### 1 General

#### 1.1

##### 1.1.1 (1/1/2020)

This Section is void, as there are no additional class requirements.

## SECTION 8

## CARGO TANK VENTING SYSTEM

### 1 Pressure relief systems

#### 1.1 Cargo tank

##### 1.1.1 Size of pressure relief devices (1/1/2020)

IGC CODE REFERENCE : Ch 8, 8.4.1.2 and Figure 8.1

For application of the formula in paragraph 8.4.1.2 of the IGC Code, the following is to be applied for prismatic tanks:

- $L_{min}$ , for non-tapered tanks, is the smaller of the horizontal dimensions of the flat bottom of the tank. For tapered tanks, as would be used for the forward tank,  $L_{min}$  is the smaller of the length and the average width.
- For prismatic tanks whose distance between the flat bottom of the tank and bottom of the hold space is equal to or less than  $L_{min}/10$ :  
A = external surface area minus flat bottom surface area.
- For prismatic tanks whose distance between the flat bottom of the tank and bottom of the hold space is greater than  $L_{min}/10$ :  
A = external surface area.

#### 1.2 Interbarrier spaces

##### 1.2.1 Protection of interbarrier spaces (1/1/2020)

IGC CODE REFERENCE : Ch 8, 8.2.2

- The formula for determining the relieving capacity given in [1.2.2] is developed for interbarrier spaces surrounding independent type A cargo tanks, where the thermal insulation is fitted to the cargo tanks.
- The relieving capacity of pressure relief devices of interbarrier spaces surrounding independent type B cargo tanks may be determined on the basis of the method given in [1.2.2]; however, the leakage rate is to be determined in accordance with 4.7.2 of the IGC Code.
- The relieving capacity of pressure relief devices for interbarrier spaces of membrane and semi-membrane tanks is to be evaluated on the basis of specific membrane/semi-membrane tank design.
- The relieving capacity of pressure relief devices for interbarrier spaces adjacent to integral type cargo tanks may, if applicable, be determined as for type A independent cargo tanks.

##### 1.2.2 Size of pressure relief devices (1/1/2020)

IGC CODE REFERENCE : Ch 8, 8.4

The combined relieving capacity (in  $m^3/s$ ) of the pressure relief devices for interbarrier spaces surrounding type A independent cargo tanks where the insulation is fitted to the cargo tanks may be determined by the following formula:

$$Q_{sa} = 3,4 \cdot A_c \cdot \frac{\rho}{\rho_v} \cdot \sqrt{h}$$

where:

$Q_{sa}$  : Minimum required discharge rate of air in standard conditions of 273 K and 1.013 bar

$A_c$  : Design crack opening area in ( $m^2$ )

$$A_c = \frac{\pi}{4} \cdot \delta \cdot l$$

with:

$\delta$  : Max. crack opening width in (m)

$$\delta = 0,2 \cdot t$$

t : Thickness of tank bottom plating in (m)

l : Design crack length in (m) equal to the diagonal of the largest plate panel of the tank bottom (see Fig 1)

h : Max. liquid height above tank bottom plus  $10 \times$  MARVS in (m)

$\rho$  : Density of product liquid phase in  $kg/m^3$  at the set pressure of the interbarrier space relief device

$\rho_v$  : Density of product vapour phase in  $kg/m^3$  at the set pressure of the interbarrier space relief device and a temperature of 273 K.

MARVS : max allowable relief valve setting of the cargo tank (bar)

#### 1.3 Vents

##### 1.3.1 (1/1/2020)

IGC CODE REFERENCE : Ch 8, 8.2.10

The height of vent exits as indicated in paragraph 8.2.10 of the IGC Code is also to be measured above storage tanks and cargo liquid lines, where applicable.

#### 1.4 Segregation of vents

##### 1.4.1 Additional requirements on vent location (1/1/2020)

IGC CODE REFERENCE : Ch 8, 8.2.11.1 and 8.2.11.2

- The distances of the vent exits are to be measured horizontally.
- In the case of carriage of flammable and/or toxic products, the vent exits are to be arranged at a distance of at least 5 m from exhaust ducts and at least 10 m from intake ducts serving cargo pump rooms and/or cargo compressor rooms.
- The distances are also intended to refer to outlets of ventilation ducts of safe spaces.



Figure 1 : Determination of I

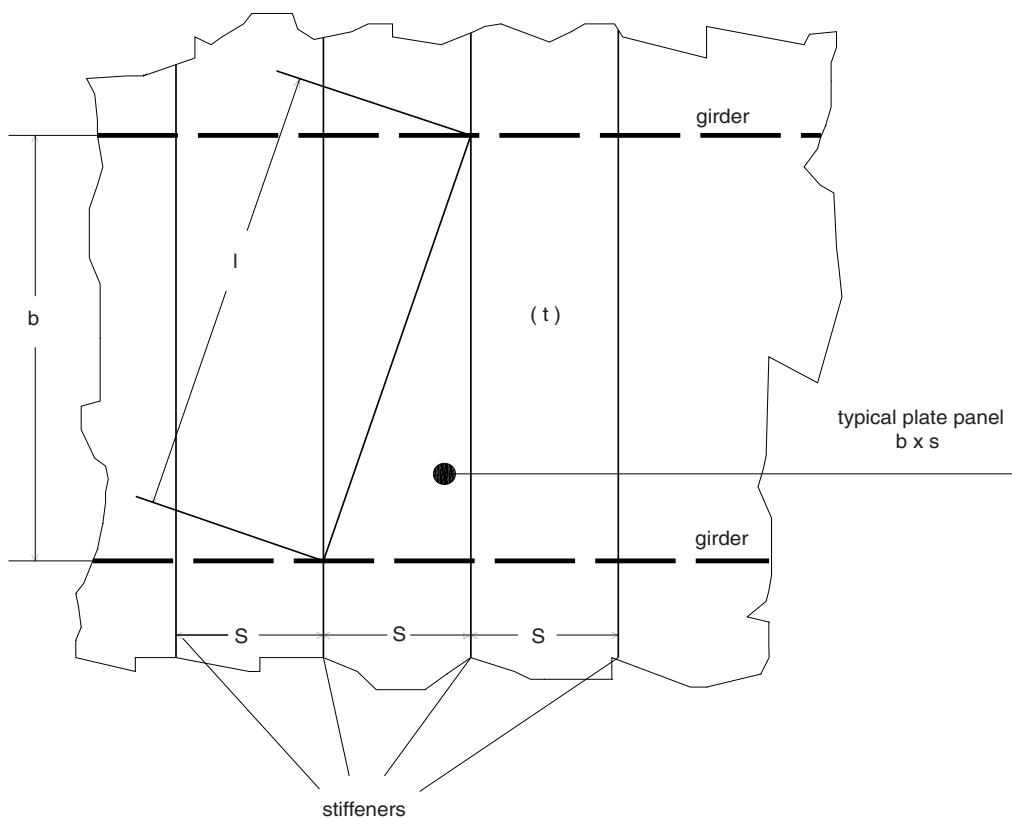

## 2 Additional pressure relieving system for liquid level control

### 2.1 General

#### 2.1.1 Tank filling limits (1/1/2020)

IGC CODE REFERENCE : Ch 13, 13.3.2

The words 'to prevent the tank from becoming liquid full' in paragraph 13.3.2 of the IGC Code have the following meaning:

At no time during the loading, transport or unloading of the cargo including fire conditions will the tank be more than 98% liquid full, except as permitted by 15.4.1 of the IGC Code. These requirements, together with those of 8.2.17 of the IGC Code, are intended to ensure that the pressure relief valves remain in the vapour phase.

## SECTION 9

## ENVIRONMENTAL CONTROL

### 1 Inerting

#### 1.1 General

##### 1.1.1 Dew point

IGC CODE REFERENCE : Ch 9, 9.4.1

As far as the IGC Code requirements relevant to the dew point are concerned, the following additional provisions apply:

- a) where cargo tank insulation is not protected from water vapour penetration by means of an effective vapour barrier, accepted by the Society, the maximum value of the dew point is to be less than the design temperature
- b) where cargo tank insulation is protected by an effective vapour barrier, accepted by the Society, the maximum value of the dew point is to be less than the minimum temperature which may be found on any surface within the spaces filled with dry inert gas or dry air
- c) the temperature of the hull structures adjacent to cargo tanks is not to become lower than the minimum permissible working temperature, specified in Section 6, for the steel grade employed for such hull structures.

##### 1.1.2 Precautions against fire

IGC CODE REFERENCE : Ch 9, 9.4.1

Precautions are to be taken to minimise the risk that static electricity generated by the inert gas system may become a source of ignition.

### 2 Inert gas production on board

#### 2.1 Exemptions

##### 2.1.1

IGC CODE REFERENCE : Ch 9, 9.5

- a) Inert gas generating systems are to be considered as essential services and are to comply with the applicable Sections of the Rules, as far as applicable.
- b) Where, in addition to inert gas produced on board, it is possible to introduce dry air into the above-mentioned spaces, where this is acceptable depending on the type of cargo tank adopted, or to introduce inert gas from a supply existing on board, it is not necessary that standby or spare components for the inert gas system are kept on board.

## SECTION 10

## ELECTRICAL INSTALLATIONS

### 1 General

#### 1.1 Application

**1.1.1** The requirements in this Section apply, in addition to those contained in Part C, Chapter 2, to ships with the service notation gas carrier.

#### 1.2 Documentation to be submitted

**1.2.1** In addition to the documentation requested in Pt C, Ch 2, Sec 1, Tab 1, the following are to be submitted for approval:

- a) plan of hazardous areas
- b) document giving details of types of cables and safety characteristics of the equipment installed in hazardous areas
- c) diagrams of tank level indicator systems, high level alarm systems and overflow control systems where requested.

#### 1.3 System of supply

##### 1.3.1 (1/1/2007)

Earthed systems with hull return are not permitted, with the following exceptions to the satisfaction of the Society:

- a) impressed current cathodic protective systems
- b) limited and locally earthed systems, such as starting and ignition systems of internal combustion engines, provided that any possible resulting current does not flow directly through any hazardous area
- c) insulation level monitoring devices, provided that the circulation current of the device does not exceed 30 mA under the most unfavourable conditions
- d) intrinsically safe systems.

##### 1.3.2 (1/1/2007)

In insulated distribution systems, no current carrying part is to be earthed, other than:

- a) through an insulation level monitoring device
- b) through components used for the suppression of interference in radio circuits.

##### 1.3.3 (1/7/2009)

The additional limitations in the choice of the system of supply (type of distribution system) as per SOLAS Ch.II-1 Reg. 45.4.3 apply to ships subject to the SOLAS Convention.

#### 1.4 Earth detection

##### 1.4.1 (1/1/2007)

For both insulated and earthed distribution systems a device, or devices, are to be installed to continuously mon-

itor the insulation to earth and to give an audible and visual alarm at a manned position in the event of an abnormally low level of insulation resistance and/or high level of leakage current.

The above is not applicable to systems mentioned in [1.3.1].

#### 1.5 Precautions against inlet of gases or vapours

**1.5.1** Suitable arrangements are to be provided, to the satisfaction of the Society, so as to prevent the possibility of gases or vapours passing from a gas-dangerous space to another space through runs of cables or their conduits.

#### 1.6 Electrical equipment permitted in hazardous areas

##### 1.6.1 (1/1/2007)

Electrical equipment permitted in hazardous areas is that indicated in Pt C, Ch 2, Sec 3, [10.1.4], Pt C, Ch 2, Sec 3, [10.1.5][ and Pt C, Ch 2, Sec 3, [10.1.6].

##### 1.6.2 (1/1/2007)

In addition to the requirements of [1.6.1], in Zone 1 and Zone 2 the installation of the following is permitted: hull fittings containing the terminals or shell plating penetrations for anodes or electrodes of an impressed current cathodic protection system, or transducers such as those for depth sounding or log systems, provided that such fittings are of gas-tight construction or housed within a gas-tight enclosure, and are not located adjacent to a cargo tank bulkhead. The design of such fittings or their enclosures and the means by which cables enter, as well as any testing to establish their gas-tightness, are to be to the satisfaction of the Society. The associated cables are to be protected by means of heavy gauge steel pipes with gas-tight joints.

##### 1.6.3 (1/1/2007)

Enclosed or semi-enclosed spaces (not containing a source of hazard) having a direct opening, including those for ventilation, into any hazardous area, are to be designated as the same hazardous zone as the area in which the opening is located.

Electrical installations are to comply with the requirements for the space or area into which the opening leads.

Note 1: For openings, access and ventilation conditions affecting the extent of hazardous areas, see IEC Standard 60092-502.

## 2 Hazardous locations

### 2.1 Hazardous area classification

#### 2.1.1 (1/1/2007)

For hazardous area classification see Tab 1.

## 2.2 Submerged cargo pumps

### 2.2.1 Exceptions

Submerged cargo pumps are not permitted in connection with the following cargoes:

- diethyl ether
- vinyl ethyl ether
- ethylene oxide
- propylene oxide
- mixtures of ethylene oxide and propylene oxide.

### 2.2.2 Submerged electric motors

a) Where submerged electric motors are employed, means are to be provided, e.g. by the arrangements specified in paragraph 17.6 of the IGC Code, to avoid the formation

of explosive mixtures during loading, cargo transfer and unloading.

b) Arrangements are to be made to automatically shut down the motors in the event of low liquid level. This may be accomplished by sensing low pump discharge pressure, low motor current, or low liquid level. This shutdown is to be alarmed at the cargo control station. Cargo pump motors are to be capable of being isolated from their electrical supply during gas-freeing operations.

## 3 Product classification

### 3.1 Temperature class and explosion group

#### 3.1.1

Tab 2 specifies temperature class and explosion group data for the products indicated in Chapter 19. The data shown in brackets have been derived from similar products.

**Table 1 : Classification of hazardous areas for tankers carrying flammable liquefied gases (1/1/2007)**

Spaces		Hazardous area
No.	Description	
1	Cargo containment systems	Zone 0
2	Hold spaces where cargo is carried in a cargo containment system requiring a secondary barrier	Zone 0
3	Hold spaces where cargo is carried in a cargo containment system not requiring a secondary barrier	Zone 1
4	Space separated from a hold space where cargo is carried in a cargo containment system requiring a secondary barrier by a single gas-tight steel boundary	Zone 1
5	Cargo pump and cargo compressor rooms	Zone 1
6	Areas on open deck, or semi-enclosed spaces on open deck, within 3 m of any cargo tank outlet, gas or vapour outlet, cargo manifold valve, cargo valve, cargo pipe flange, cargo pump and cargo compressor room ventilation outlets and cargo tank openings for pressure release provided to permit the flow of small volumes of gas or vapour mixtures caused by thermal variation	Zone 1
7	Areas on open deck, or semi-enclosed spaces on open deck above and in the vicinity of any cargo gas outlet intended for the passage of large volumes of gas or vapour mixture during cargo loading and ballasting or during discharging, within a vertical cylinder of unlimited height and 6 m radius centred upon the centre of the outlet, and within a hemisphere of 6 m radius below the outlet	Zone 1
8	Areas on open deck, or semi-enclosed spaces on open deck, within 1,5 m of cargo pump and cargo compressor room entrance, cargo pump and cargo compressor room ventilation inlet, openings into cofferdams or other zone 1 spaces	Zone 1
9	Areas on open deck within spillage coamings surrounding cargo manifold valves and 3 m beyond these, up to a height of 2,4 m above the deck	Zone 1
10	Areas on open deck over all cargo tanks (including ballast tanks within the cargo tank area) where structure restricts natural ventilation and to the full breadth of the ship plus 3 m fore and aft of the forward-most and aft-most cargo tank bulkhead, up to a height of 2,4 m above the deck	Zone 1
11	Compartment for cargo hoses	Zone 1
12	Enclosed or semi-enclosed spaces in which pipes containing cargoes are located	Zone 1
(1)	For ships subject to the SOLAS Convention, an area within 2m beyond the 3m of cargo tank ventilation outlets which permit the flow of small volumes of vapour gas mixtures caused by thermal variation is to be considered Zone 2	

Spaces		Hazardous area
No.	Description	
13	Enclosed or semi-enclosed spaces in which pipes containing cargo products for boil-off gas fuel burning systems are located, unless special precautions approved by the Society are provided to prevent product gas escaping into such spaces	Zone 1
14	Areas of 1,5 m surrounding open or semi-enclosed spaces of Zone 1 <b>(1)</b>	Zone 2
15	Areas 4 m beyond the cylinder and 4 m beyond the sphere defined in item 7	Zone 2
16	Spaces forming an air-lock	Zone 2
17	Areas on open deck extending to the coamings fitted to keep any spills on deck and away from the accommodation and service areas and 3m beyond these up to a height of 2,4m above the deck	Zone 2
18	Areas on open deck over all cargo tanks (including all ballast tanks within the cargo tank area) where unrestricted natural ventilation is guaranteed and to the full breadth of the ship plus 3 m fore and aft of the forward-most and aft-most cargo tank bulkhead, up to a height of 2,4 m above the deck surrounding open or semi-enclosed spaces of Zone 1	Zone 2
19	Spaces forward of the open deck areas to which reference is made in item 10 and item 18, below the level of the main deck, and having an opening on the main deck or at a level less than 0,5 m above the main deck, unless: a) the entrances to such spaces do not face the cargo tank area and, together with all other openings to the spaces, including ventilation system inlets and exhausts, are situated at least 5 m from the foremost cargo tank and at least 10 m measured horizontally from any cargo tank outlet or gas or vapour outlet; and b) the spaces are mechanically ventilated	Zone 2
20	Areas within 2,4 m of the outer surface of a cargo tank where such surface is exposed to the weather	Zone 2
<b>(1)</b> For ships subject to the SOLAS Convention, an area within 2m beyond the 3m of cargo tank ventilation outlets which permit the flow of small volumes of vapour gas mixtures caused by thermal variation is to be considered Zone 2		

Table 2 : Temperature class and explosion group of certain products (1/1/2010)

Product name	Temperature class	Explosion group	Product name	Temperature class	Explosion group
Acetaldehyde	T4	II A	Methane	T1	II A
Ammonia anhydrous	T1	II A	Methyl acetylene propadiene mixture	T4	II A
Butadiene	T2	II B	Methyl bromide	T3	II A
Butane	T2	II A	Methyl chloride	T1	II A
Butane/propane mixture	T2	II A	Monoethylamine	T2	II A
Butylenes	T3	II A	Nitrogen	NF	NF
Chlorine	NF	NF	Pentane (all isomers)	(T2)	(II A)
Diethyl ether	T4	II B	Pentene (all isomers)	(T3)	(II B)
Dimethylamine	T2	II A	Propane	T2	II A
Ethane	T2	II A	Propylene	T2	II B
Ethyl chloride	T2	II A	Propylene oxide	T2	II B
Ethylene	T2	II B	Refrigerant gases	NF	NF
Ethylene oxide	T2	II B	Sulphur dioxide	(T3)	(II B)

**Pt E, Ch 9, Sec 10**

Product name	Temperature class	Explosion group	Product name	Temperature class	Explosion group
Ethylene oxide propylene oxide mixture (max. 30% mass/mass ethylene oxide)	T2	II B	Vinyl chloride	T2	II A
Isoprene	T3	II B	Vinyl ethyl ether	T3	II B
Isopropylamine	T2	II A	Vinylidene chloride	T2	II A

## SECTION 11

## FIRE PROTECTION AND FIRE EXTINCTION

### 1 General

#### 1.1

##### 1.1.1 (1/1/2007)

This Section is void, as the provisions of Chapter 11 of the IGC Code are not mandatory for the class.

# SECTION 12 MECHANICAL VENTILATION IN THE CARGO AREA

## 1 Spaces required to be entered during normal cargo handling operations

### 1.1 Location of discharges from dangerous spaces

#### 1.1.1 Ventilation duct arrangement (1/1/2020)

IGC CODE REFERENCE : Ch 12, 12.1.5

- a) Ventilation ducts are to be fitted with metallic shut-off dampers provided with "open" and "closed" signs. These dampers are to be arranged in the open, in a readily accessible position.
- b) Gas-dangerous spaces for the purpose of 1.1.1.a) are those mentioned in paragraph 12.1.1 of the IGC Code. For other spaces which are gas-dangerous only due to their position, some relaxation may be granted.

### 1.2 Recirculation prevention

#### 1.2.1 (1/1/2020)

IGC CODE REFERENCE : Ch 12, 12.1.5

- a) Exhaust ducts from gas-dangerous spaces are to be arranged at a distance in the horizontal direction of at least 10 m from ventilation outlets of gas-safe spaces. Shorter distances may be accepted for ventilation outlets from safe spaces protected by air-locks.
- b) Intakes of gas-dangerous spaces are to be arranged at a distance in the horizontal direction of at least 3 m from ventilation intakes and outlets and openings of accommodation spaces, control stations and other gas-safe spaces.
- c) Exhaust and intake ducts for the same gas-dangerous space, or for the same space rendered safe by an air-lock, are to be arranged at a distance from each other in the horizontal direction of not less than 3 m.

### 1.3 Additional requirements for non-sparking fans

#### 1.3.1 Non-sparking fans (1/1/2020)

IGC CODE REFERENCE : Ch 12, 12.1.7

- a) A fan is considered as non-sparking if in both normal or abnormal conditions it is unlikely to produce sparks.
- b) The air gap between the impeller and the casing is to be not less than 0,1 of the shaft diameter in way of the impeller bearing and not less than 2 mm. It need not be more than 13 mm.

#### 1.3.2 Materials for non-sparking fans (1/1/2020)

IGC CODE REFERENCE : Ch 12, 12.1.7

- a) The impeller and the housing in way of the impeller are to be made of materials as per list in the Code, with a production certificate.
- b) Electrostatic charges both in the rotating body and the casing are to be prevented by the use of antistatic materials. Furthermore, the installation on board of the ventilation units is to be such as to ensure their safe bonding to the hull.
- c) The following impellers and housings are considered as sparking and are not permitted:
  - impellers of an aluminium alloy or magnesium alloy and a ferrous housing, regardless of tip clearance
  - housing made of an aluminium alloy or a magnesium alloy and a ferrous impeller, regardless of tip clearance
  - any combination of ferrous impeller and housing with less than 13 mm design tip clearance.

#### 1.3.3 Type test for non-sparking fans (1/1/2020)

IGC CODE REFERENCE : Ch 12, 12.1.7

Type tests on the finished product are to be carried out in accordance with the requirements of the Society or an equivalent national or international standard.

#### 1.3.4 Motor shafting (1/1/2020)

IGC CODE REFERENCE : 12, 12.1.7

The shafting penetration of motors driving fans through bulkheads and decks of dangerous spaces or through ventilation ducts is to be fitted with a gas-tight sealing device, of the oil-seal type or equivalent, deemed suitable by the Society.

## 2 Spaces not normally entered

### 2.1 General requirements

#### 2.1.1 Minimum number of air changes (1/1/2020)

IGC CODE REFERENCE : 12, 12.2

Both fixed and portable systems are to guarantee the efficient ventilation of such spaces in relation to the relative density, in respect of the air, and to the toxicity of the gases transported. The type of portable fans and their connection to the spaces served are to be approved by the Society. In no case are portable electrical fans acceptable.



## SECTION 13

## INSTRUMENTATION (GAUGING, GAS DETECTION)

### 1 General

#### 1.1 Cargo tank instrumentation

**1.1.1** The instrumentation is to be of a type approved by the Society.

#### 1.2 Detection of leak through secondary barrier

##### 1.2.1 (1/1/2020)

IGC CODE REFERENCE : Ch. 13, 13.7.1

Upon special approval, appropriate temperature indicating devices may be accepted by the Society instead of gas detecting devices when the cargo temperature is not lower than  $-55^{\circ}\text{C}$ .

#### 1.3 Indicator location

##### 1.3.1 Monitoring list (1/1/2020)

IGC CODE REFERENCE : Ch. 13, 13.1.2

The following information and alarms are to be concentrated in the positions specified in this requirement.

- a) The following is to be transduced to the "cargo control room" and the "control position" as defined in 3.4.1 of the IGC Code:
- 1) the indication signalling the presence of water and/or liquid cargo in holds or interbarrier spaces
  - 2) the cargo heater low temperature alarm
  - 3) the alarm signalling the presence of liquid cargo in the vent main as per 5.2.2.4 of the IGC Code
  - 4) the indication of the hull temperature and the hull structure low temperature alarm required in 13.7.2.2 of the IGC Code
  - 5) the alarm signalling the automatic shutdown of electrically driven submerged pumps required in 10.2.9 of the IGC Code
  - 6) the indication of the cargo level and the cargo tank high level alarm required in 13.3.1 of the IGC Code
  - 7) the indication of the vapour space pressure and the vapour space pressure gauges of each cargo tank and associated high and low pressure alarms required in 13.4.1 of the IGC Code
  - 8) the gas detection equipment alarm required in 13.6.13 of the IGC Code
  - 9) the cargo compressor high temperature alarm required in 17.4.2.2 of the IGC Code
  - 10) the alarm for automatic shutdown of the cargo compressor for high pressure or high temperature, as required in 17.16.4.4 of the IGC Code.
- b) Independently of the above, the following is to be transduced to the wheelhouse:
- 1) the alarm signalling the presence of water and/or liquid cargo in holds or interbarrier spaces
  - 2) the cargo heater low temperature alarm
  - 3) the alarm signalling the presence of liquid cargo in the vent main as per 5.2.2.4 of the IGC Code
  - 4) the indication of the pressure value in the vapour space of each cargo tank mentioned in 13.4.1 of the IGC Code; such indication is to give the setting pressure value of the relief valve and the minimum allowable pressure value in the cargo tank concerned
  - 5) the high pressure and low pressure alarms, when required, for cargo tanks as per 13.4.2 of the IGC Code
  - 6) the hull structure low temperature alarm required in 13.7.2.2 of the IGC Code
  - 7) the gas detection equipment alarm required in 13.6.13 of the IGC Code
  - 8) the cargo compressor high temperature alarm required in 17.4.2.2 of the IGC Code
  - 9) the alarm for automatic shutdown of the cargo compressor for high pressure or high temperature, as required in 17.16.4.4 of the IGC Code.
- c) Where the cargo control room is located within the accommodation spaces and is readily accessible, the alarms in (b) may be grouped in a single audible and visual alarm except for the indication and alarms in 4), 5) and 7), which are to be independent from each other.
- d) The high level and high or low pressure audible and visual alarms for cargo tanks as per 13.3.1 to 13.3.3 and 13.4.1 to 13.4.3 of the IGC Code and the alarm signalling the presence of liquid in the vent main are to be located in such a position as to be clearly heard and identifiable by the personnel in charge of loading operation control.

When the cargo system is not remote controlled and therefore the aforesaid "control positions" are not required, the above-mentioned controls, information and alarms are to be located in a suitable, easily accessible location.

If this position is an enclosed space, it is to comply with the requirements of 3.4 of the IGC Code. This position should preferably be located in the wheelhouse.

## 2 Level indicators for cargo tanks

### 2.1 General

#### 2.1.1 (1/1/2020)

IGC CODE REFERENCE : Ch. 13, 13.2.1 and 13.2.2

- a) In order to assess whether or not one level gauge is acceptable, the wording "can be maintained" is to be interpreted to mean that any part of the level gauge other than passive parts can be overhauled while the cargo tank is in service.

Passive parts are those parts assumed not subject to failures under normal service conditions.

- b) Where level gauges containing cargo are arranged outside the tank they serve, means are to be provided to shut them off automatically in the event of failure.

## 3 Overflow control

### 3.1 Overflow alarm and shutdown

#### 3.1.1 Shut-off valve for overflow control (1/1/2020)

IGC CODE REFERENCE : Ch. 13, 13.3.2

The sensor for automatic closing of the loading valve for overflow control may be combined with the liquid level indicators required by paragraph 13.2.1 of the IGC Code.

#### 3.1.2 Shut-off valve closing time (1/1/2020)

IGC CODE REFERENCE : Ch. 13, 13.3.1 to 13.3.3

The closing time of the valve referred to in 13.3.2 in seconds (i.e. time from shutdown signal initiation to complete valve closure) is to be not greater than:

$$\frac{3600 \cdot U}{LR}$$

where:

- U : Ullage volume at operating signal level (m<sup>3</sup>)  
 LR : Maximum loading rate agreed between ship and shore facility (m<sup>3</sup>/h)

The loading rate is to be adjusted to limit surge pressure on valve closure to an acceptable level taking into account the loading hose or arm, and the ship and shore piping systems, where relevant.

## 4 Pressure gauges

### 4.1 Pressure gauges in cargo tanks

#### 4.1.1

IGC CODE REFERENCE : Ch. 13, 13.4.1

The low pressure alarm indicated in paragraph 13.4.1 of the IGC Code is also to be located in the cargo control room.

## 5 Temperature indicating devices

### 5.1 General

#### 5.1.1 Temperature recording

IGC CODE REFERENCE : Ch. 13, 13.5.1

The temperatures are to be continuously recorded at regular intervals. Audible and visual alarms are to be automatically activated when the hull steel temperature approaches the lowest temperature for which the steel has been approved.

## 6 Gas detection requirements

### 6.1 Gas Measurements

#### 6.1.1 (1/1/2007)

In addition to the provisions of [6.2] to [6.3], the fitting of gas measuring equipment is subject to the those of Pt C, Ch 4, Sec 1, [5.2.4] b).

### 6.2 Position of sampling heads

#### 6.2.1 (1/1/2020)

IGC CODE REFERENCE : Ch. 13, 13.6.12

Sampling heads in cargo holds are not to be located in positions where bilge water may collect.

### 6.3 Gas sampling lines

#### 6.3.1 (1/1/2020)

IGC CODE REFERENCE : Ch. 13, 13.6.8

Gas sampling lines are to be located outside accommodation spaces, unless they are fitted within gas-tight pipes.

### 6.4 Protected spaces

#### 6.4.1 (1/1/2020)

IGC CODE REFERENCE : Ch. 13, 13.6.2

In addition to the list in paragraph 13.6.2 of the IGC Code, the gas detection system is also to serve spaces adjacent to pump rooms and compressor rooms.

### 6.5 Portable gas detectors

#### 6.5.1 (1/1/2020)

IGC CODE REFERENCE : Ch. 13, 13.6.19

For ships intended to carry toxic and flammable gases, two sets for toxic gases and two sets for flammable gases are to be provided.

## SECTION 14

## PROTECTION OF PERSONNEL

### 1 Personnel protection requirements for individual products

#### 1.1 Showers and eye wash

##### 1.1.1 (1/7/2020)

IGC CODE REFERENCE : Ch 14, 14.4.3

The showers and eye wash are to be fitted with a heating system, or other suitable installation, in order to avoid any ice formation in their piping.

## **SECTION 15**

## **FILLING LIMITS FOR CARGO TANKS**

### **1 General**

#### **1.1**

**1.1.1** This Section is void, as there are no additional or alternative requirements to those indicated in Chapter 15 of the IGC Code.

## SECTION 16

## USE OF CARGO AS FUEL

### 1 Gas fuel supply

#### 1.1 Piping

##### 1.1.1 Piping runs (1/1/2020)

IGC CODE REFERENCE : Ch. 16, 16.4.1 to 16.4.3

- a) The main gas line between the gas make-up station and the machinery space is to be as short as possible.
- b) The gas piping is to be installed as high in the space as possible and at the greatest possible distance from the ship's hull.

##### 1.1.2 Segregation of piping (1/1/2020)

IGC CODE REFERENCE : Ch. 16, 16.4

Gas piping is to be independent of other systems and may only be used for the conveyance of gas. It is to be ensured by its arrangement that it is protected against external damage.

##### 1.1.3 Earthing (1/1/2020)

IGC CODE REFERENCE : Ch. 16, 16.4

Gas piping is to be suitably earthed.

##### 1.1.4 Testing (1/1/2020)

IGC CODE REFERENCE : Ch. 16, 16.4

Piping, valves and fittings are to be hydrostatically tested, after assembly on board, to 1,5 times the working pressure but to not less than 0,7 MPa. Subsequently, they are to be pneumatically tested to ascertain that all the joints are perfectly tight.

#### 1.2 Valves

##### 1.2.1 Automatic operation (1/1/2020)

IGC CODE REFERENCE : Ch. 16, 16.4.5

It is to be possible to operate the valves indicated in paragraph 16.4.5 of the IGC Code locally and from each control platform. They are to close automatically under the following service conditions:

- a) whenever the gas pressure varies by more than 10 % or, in the case of supercharged engines, if the differential pressure between gas and charging air is no longer constant
- b) in the event of one of the following fault situations:
  - 1) Gas supply to boiler burners
    - insufficient air supply for complete combustion of the gas
    - extinguishing of the pilot burner for an operating burner, unless the gas supply line to every indi-

vidual burner is equipped with a quick-closing valve that automatically cuts off the gas

- low pressure of the gas
- 2) Gas supply to internal combustion engines
    - failure of supply to pilot fuel injection pump, if any
    - drop of engine speed below the lowest service speed

### 2 Gas fuel plant and related storage tanks

#### 2.1 General

##### 2.1.1 Location of equipment for making up gas (1/1/2020)

IGC CODE REFERENCE : Ch. 16, 16.5

Means for purging of flammable gases before opening are to be provided in the equipment for making up gas.

##### 2.1.2 Equipment located on weather deck (1/1/2020)

IGC CODE REFERENCE : Ch. 16, 16.5

Where the equipment (heaters, compressors, filters) for making up the gas for its use as fuel and the storage tanks are located on the weather deck, they are to be suitably protected from atmospheric agents and the sea.

#### 2.2 Compressors

##### 2.2.1 Miscellaneous requirements (1/1/2020)

IGC CODE REFERENCE : Ch. 16, 16.5.2

- a) The compressors are to be capable of being remotely stopped from an always and easily accessible, non-dangerous position in the open, and also from the engine room.
- b) In addition, the compressors are to be capable of automatically stopping when the suction pressure reaches a certain value depending on the setting pressure of the vacuum relief valves of the cargo tanks.
- c) The automatic shutdown device of the compressors is to have a manual resetting.
- d) Piston-type compressors are to be fitted with relief valves discharging to a position in the open, such as not to give rise to hazards.
- e) The compressors are to be fitted with shut-off valves and flame screens on both the suction and delivery sides.

## 2.3 Heaters

### 2.3.1 Additional miscellaneous requirements (1/1/2020)

IGC CODE REFERENCE : Ch. 16, 16.5.3

- a) Operation of the heaters is to be automatically regulated depending on the gas temperature at the heater outlet.
- b) Before it is returned to the machinery space, the heating medium (steam or hot water) is to go through a degassing tank located in the cargo area.
- c) Provisions are to be made to detect and signal the presence of gas in the tank. The vent outlet is to be in a safe position and fitted with a flame screen.

## 3 Special requirements for main boilers

### 3.1 Boiler arrangement

#### 3.1.1 Forced air circulation (1/1/2020)

IGC CODE REFERENCE : Ch. 16, 16.6

Boilers are to be located as high as possible in boiler spaces and are to be of the membrane wall type or equivalent, so as to create a space with forced air circulation between the membrane wall and the boiler casing .

### 3.2 Combustion chamber

#### 3.2.1 Gas detectors in the combustion chamber (1/1/2020)

IGC CODE REFERENCE : Ch. 16, 16.6.1.3

The Society may, at its discretion, require gas detectors to be fitted in those combustion chamber areas where gas could accumulate, as well as the provision of suitable air nozzles.

### 3.3 Burner system

#### 3.3.1 Safety devices (1/1/2020)

IGC CODE REFERENCE : Ch. 16, 16.6.2

A mechanical device is to be installed to prevent the gas valve from opening until the air and the fuel oil controls are in the ignition position. A flame screen, which may be incorporated in the burner, is to be fitted on the pipe of each gas burner.

## 4 Special requirements for gas fired internal combustion engines and gas fired turbines

### 4.1 Gas fuel supply to engine

#### 4.1.1 Flame arresters (1/1/2020)

IGC CODE REFERENCE : Ch. 16, 16.7 and 16.8

Flame arresters are to be provided at the inlet to the gas supply manifold for the engine.

#### 4.1.2 Manual shut-off (1/1/2020)

IGC CODE REFERENCE : Ch. 16, 16.7 and 16.8

Arrangements are to be made so that the gas supply to the engine can be shut off manually from the starting platform or any other control position.

#### 4.1.3 Prevention of fatigue failure (1/1/2020)

IGC CODE REFERENCE : Ch. 16, 16.7 and 16.8

The arrangement and installation of the gas piping are to provide the necessary flexibility for the gas supply piping to accommodate the oscillating movements of the engines without risk of fatigue failure.

#### 4.1.4 Protection of gas line connections (1/1/2020)

IGC CODE REFERENCE : Ch. 16, 16.7 and 16.8

The connecting of gas line and protection pipes or ducts as per [4.2.1] to the gas fuel injection valves is to provide complete coverage by the protection pipe or ducts.

### 4.2 Gas fuel supply piping systems

#### 4.2.1 Fuel piping in machinery spaces (1/1/2020)

IGC CODE REFERENCE : Ch. 16, 16.7 and 16.8

Gas fuel piping may pass through or extend into machinery spaces or gas-safe spaces other than accommodation spaces, service spaces and control stations provided that they fulfil one of the following conditions:

- a) The system complies with paragraph 16.4.1.1 of the IGC Code, and in addition, with 1, 2 and 3 below:
  - 1) The pressure in the space between concentric pipes is monitored continuously. Alarm is to be issued and the automatic valves specified in 16.4.5 of the IGC Code (hereafter referred to as "interlocked gas valves") and the master gas fuel valves specified in 16.4.6 of the IGC Code (hereafter referred to as "master gas valves") are to be closed before the pressure drops to below the inner pipe pressure (however, an interlocked gas valve connected to the vent outlet is to be opened).
  - 2) The construction and strength of the outer pipes are to comply with the requirements of 5.2 of the IGC Code.
  - 3) It is to be so arranged that the inside of the gas fuel supply piping system between the master gas valve and the engine is automatically purged with inert gas when the master gas valve is closed; or
- b) The system complies with paragraph 16.4.3 of the IGC Code, and in addition, with 1 to 4 below:
  - 1) The materials, construction and strength of protection pipes or ducts and mechanical ventilation systems are to be sufficiently durable against bursting and rapid expansion of high pressure gas in the event of gas pipe burst.
  - 2) The capacity of mechanical ventilating systems is to be determined considering the flow rate of gas fuel and construction and arrangement of protective

pipes or ducts, as deemed appropriate by the Society.

- 3) The air intakes of mechanical ventilating systems are to be provided with non-return devices effective for gas fuel leaks. However, if a gas detector is fitted at the air intakes, this requirement may be dispensed with.
- 4) The number of flange joints of protective pipes or ducts is to be minimised; or
- c) Alternative arrangements to those given in a) and b) will be specially considered by the Society based upon an equivalent level of safety.

#### **4.2.2 Valves and expansion joints (1/1/2020)**

IGC CODE REFERENCE : Ch. 16, 16.7 and 16.8

All valves and expansion joints used in high pressure gas fuel supply lines are to be of an approved type.

#### **4.2.3 Pipe joints (1/1/2020)**

IGC CODE REFERENCE : Ch. 16, 16.7 and 16.8

Joints on the entire length of the gas fuel supply lines are to be butt-welded joints with full penetration and to be fully radiographed, except where specially approved by the Society.

#### **4.2.4 Non-welded pipe joints (1/1/2020)**

IGC CODE REFERENCE : Ch. 16, 16.7 and 16.8

Pipe joints other than welded joints at the locations specifically approved by the Society are to comply with the appropriate standards recognised by the Society, or with joints whose structural strength has been verified through test analysis as deemed appropriate by the Society.

#### **4.2.5 Post-weld heat treatment (1/1/2020)**

IGC CODE REFERENCE : Ch. 16, 16.7 and 16.8

For all butt-welded joints of high pressure gas fuel supply lines, post-weld heat treatment is to be performed depending on the kind of material.

### **4.3 Shut-off of gas fuel supply**

#### **4.3.1 Fuel supply shut-off (1/1/2020)**

IGC CODE REFERENCE : Ch. 16, 16.7 and 16.8

In addition to the causes specified in 16.4.5 of the IGC Code, supply of gas fuel to engines is to be shut-off by the interlocked gas valves in the event of the following abnormalities:

- a) abnormality specified in Pt C, Ch 1, App 2
- b) engine stops due to any cause.

#### **4.3.2 Master gas valve shut-off (1/1/2020)**

IGC CODE REFERENCE : Ch. 16, 16.7 and 16.8

In addition to the causes specified in 16.4.6 of the IGC Code, the master gas valve is to be closed in the event of any of the following:

- a) the oil mist detector or bearing temperature detector detects abnormality
- b) any kind of gas fuel leakage is detected
- c) abnormality specified in Pt C, Ch 1, App 2.

#### **4.3.3 Automatic operation (1/1/2020)**

IGC CODE REFERENCE : Ch. 16, 16.7 and 16.8

The master gas valve is to close automatically upon activation of the interlocked gas valves.

### **4.4 Emergency stop of dual fuel engines**

#### **4.4.1 (1/1/2020)**

IGC CODE REFERENCE : Ch. 16, 16.7 and 16.8

Dual fuel engines are to be stopped before the gas concentration detected by the gas detectors specified in 16.3.2 of the IGC Code reaches 60% of the lower flammable limit.

### **4.5 Requirements on dual fuel engines**

#### **4.5.1 (1/1/2020)**

IGC CODE REFERENCE : Ch. 16, 16.7 and 16.8

Specific requirements on internal combustion engines supplied by gas are given in Pt C, Ch 1, App 2.

## SECTION 17

## SPECIAL REQUIREMENTS

### 1 Materials for construction

#### 1.1 Materials exposed to cargo

##### 1.1.1

IGC CODE REFERENCE : Ch. 17, 17.2

Materials "exposed to cargo" are those constituting systems, cargo appliances or arrangements which are in contact with (liquid or vapour) cargo in normal operating conditions.

### 2 Inhibition

#### 2.1 Polymerisation prevention - Alternative requirement

##### 2.1.1

IGC CODE REFERENCE : Ch. 17, 17.8.1

- a) As an alternative to the addition of inhibited liquid, it may be accepted that, at the end of each refrigeration period, the liquid is completely removed from the refrigeration system by means of vapour from compressors or by means of inert gas. In such case, the following wording is to be entered on the Certificate of Fitness:

"At the end of each refrigeration period, the liquid is to be completely removed from the refrigeration system by means of vapour from compressors or by means of inert gas."

- b) On the cargo compressor delivery side, a temperature switch is to be fitted, set at a suitable temperature, depending on the characteristics of the product carried (e.g. 60°C for butadiene), giving a visual and audible alarm on the navigation bridge and in the cargo control station, if any, which causes the compressor to stop when such temperature is exceeded.

### 3 Chlorine

#### 3.1 Cargo containment system

##### 3.1.1 Relief valves (1/1/2020)

IGC CODE REFERENCE : Ch. 17, 17.13.1.4

Chlorine discharge from pressure relief valves is to be led to an absorption device deemed suitable by the Society.

### 3.2 Cargo piping system

#### 3.2.1 Piping design and fabrication (1/1/2020)

IGC CODE REFERENCE : Ch. 17, 17.13.2.2

A welding neck type flange deemed suitable is shown in Fig 1 as an example.

**Figure 1 : Suitable neck type flange**

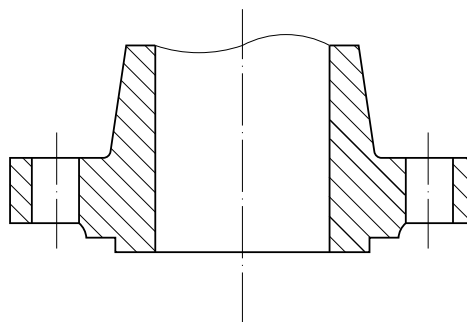

### 3.3 Instrumentation - Safety devices

#### 3.3.1 Gas detection system (1/1/2020)

IGC CODE REFERENCE : Ch. 17, 17.13.4.3

The gas detection system is to be permanently installed.

### 3.4 Protection of personnel

#### 3.4.1 Additional equipment (1/1/2020)

IGC CODE REFERENCE : Ch. 17, 17.13.5

In addition to the source of uncontaminated air, two complete and independent air breathing apparatuses, not employing oxygen supplies, each having a capacity of at least 1200 litres of non-compressed air and two sets of protective equipment, complete with gas-tight boots, gloves and eye protection, are to be provided. The above-mentioned equipment and clothing are to be kept in the space indicated in paragraph 17.13.5 of the IGC Code and are additional to those required in other parts of this Chapter.

### 3.5 Filling limits for cargo tanks

#### 3.5.1 (1/1/2020)

IGC CODE REFERENCE : Ch. 17, 17.13.6.1

When determining the filling limits of the cargo tanks for the transport of chlorine, the effect of the refrigeration plant is not to be considered.



## SECTION 18

## OPERATING REQUIREMENTS

### 1 General

#### 1.1

##### 1.1.1 (1/1/2021)

The provisions of Chapter 18 of the IGC Code are operating requirements which are not mandatory for the class, with exception of:

- 18.10.1 to 18.10.4 applicable to emergency shut down (ESD) systems; and
- 18.10.2.1.4 which is referred to in Sec 13, [3.1.2].

## SECTION 19

## SUMMARY OF MINIMUM REQUIREMENTS

## 1 Additional information on products

The list shown in Table 1 gives properties for pure products. The specific gravity to be taken into account for the design of a ship might be altered considering the actual properties of the commercial product.

## 1.1

## 1.1.1

IGC CODE REFERENCE - CHAPTER 19

Table 1 lists some additional information for those products which are listed in the table in Chapter 19 of the IGC Code.

Information on temperature classes and explosion groups for electrical equipment in connection with the products to be carried is indicated in Sec 10, Tab 2.

Table 1

Product name	Boiling temperature (°C)	Specific gravity at boiling point (kg/m <sup>3</sup> )	Ratio vapour/air density
Acetaldehyde	20,8	780	1,52
Ammonia, anhydrous	- 33,4	680	0,60
Butadiene	- 4,5	650	1,87
Butane	-0,5/11,7	600	2,02
Butylenes	- 6,3/- 7	625	1,94
Chlorine	- 34	1560	2,49
Diethyl ether	34,6	640	2,55
Dimethylamine	6,9	670	1,55
Ethane	- 88,6	549	1,04
Ethyl chloride	12,4	920	2,22
Ethylene	- 104	570	0,97
Ethylene oxide	-10,7	870	1,52
Isoprene	34,5	680	2,35
Isopropylamine	32,5	700	2,03
Methane (LNG)	-161,5	420	0,55
Methyl bromide	4,5	1730	3,27
Methyl chloride	-23,7	1000	1,78
Monoethylamine	16,6	690	1,56
Nitrogen	-196	808	0,97
Pentanes (all isomers)	36,1	610	2,6
Pentene (all isomers)	30,1/37	610	2,6
Propane	-42,3	580	1,56
Propylene	-47,7	610	1,50
Propylene oxides	34,5	860	2,00
Refrigerant gases			
Dichlorodifluoromethane (R12)	-30	1486	4,26
Dichloromonofluoroethane (R21)	8,9	1480	3,9
Dichlorotetrafluoroethane (R114)	3,8	1510	1,31
Monochlorodifluoromethane (R22)	-42	1420	2,98
Monochlorotetrafluoroethane (R124)	-	-	4,70
Monochlorotrifluoromethane (R13)	-81,4	1520	3,60
Sulphur dioxide	-10	1460	2,3
Vinyl chloride	-13,9	970	2,15
Vinyl ethyl ether	35,5	754	2,50
Vinylidene chloride	31,7	1250	3,45

# APPENDIX 1

# LNG BUNKER SHIPS

## 1 General

### 1.1 Application

#### 1.1.1 (1/1/2024)

The requirements of this Appendix apply to Liquefied Gas Carriers complying Chapter 9, and intended to load LNG from land based or offshore terminals, gas carriers or truck and transfer the LNG to LNG fuelled ships.

Ships complying with the requirements of this Appendix will be granted the additional service feature **LNG bunker** which may be complemented by one or more of the following:

- **IG-Bunker (Inert Gas Bunker)**, where the LNG bunker ship is designed to also supply inert gas, to ensure gas freeing and aeration, to a LNG fuelled ship.
- **BT (Bunker Trust)** where the LNG bunker ship is designed with arrangement for the verification of the LNG quality and quantity delivered to the receiving ship.
- **VCS-Bunker (Vapour Control System Bunker)** where the LNG bunker ship is designed with systems for control of vapour emission from cargo tanks from receiving ship during bunkering.
- **NH3 Tank Ready** where the LNG bunker ship is fitted with LNG cargo tanks designed also for ammonia storage.
- **NH3 Tank** where the LNG bunker ship is fitted with LNG cargo tanks designed, built and tested also for ammonia storage.

#### 1.1.2 (1/12/2020)

The requirements of this Appendix supplement those in Chapter 9.

In general, this Appendix does not address cargo containment and handling systems and the interfaces between these systems and the other parts of the ship, which are to comply with the applicable Sections of the Rules.

### 1.2 Scope

#### 1.2.1 (1/12/2020)

This Appendix addresses:

- the design and installation of the of the piping system of the LNG bunker ship intended to transfer LNG to the LNG fuelled ship and the vapour transfer system to/from these units.
- the safety arrangements.

#### 1.2.2 (1/12/2020)

Ships intended to load, carry and transfer gases other than LNG will be considered on a case by case basis, and the Society reserves the right to establish additional requirements.

## 2 Definitions

### 2.1 Bunker emergency shut-down system (ESD)

#### 2.1.1 (1/12/2020)

A bunker ESD is a system that safely and effectively stops the transfer of LNG (and vapour as applicable) between the receiving ship and the bunker ship in the event of an emergency during the bunkering operation, and puts the system in a safe condition.

### 2.2 Bunkering connections

#### 2.2.1 (1/12/2020)

Bunkering connections correspond to the end of the fixed piping of the LNG bunker ship (i.e. manifold for a system with flexible hose and before the swivel for a system with transfer arm).

### 2.3 Custody Transfer Measuring system

#### 2.3.1 (1/12/2020)

Custody transfer Measuring system in fluid measurement is a metering point (location) where the fluid is being measured for sale from one party to another.

### 2.4 Emergency release coupling (ERC) or breakaway coupling (BRC)

#### 2.4.1 (1/12/2020)

A breakaway coupling or emergency release coupling (ERC) is a coupling located in the LNG transfer system (at one end of the transfer system, either the receiving ship end or the LNG bunker ship end, or in the middle of the transfer system), which separates at a predetermined section when required, each separated section containing a self-closing shut-off valve, which seals automatically.

An emergency release coupling can be activated:

- by external forces applied to the predetermined section exceeding a predetermined value, and/or
- by manual, remote or automatic control, in case of emergency.

### 2.5 ESD link system or Ship-ship link (SSL)

#### 2.5.1 (1/12/2020)

ESD link system or Ship-ship or ship-shore link (SSL) is a communication system to transmit ESD signals and other signals between two different ESD systems (ship to

shore/ship or vice versa) via compatible system technologies such as pneumatic, electric, fiber-optic or radio telemetry.

## 2.6 LNG bunkering station

### 2.6.1 (1/12/2020)

LNG bunkering station means the following equipment and the area where they are fitted:

- bunkering connections (see [2.3]) for hoses and piping used for liquid and vapour return lines,
- isolating valves and emergency shut-down valves,
- drip trays, draining arrangement and other arrangements such as water curtain intended for the protection of the ship structure from cold leakages,
- gas detection system through thermal camera or gas detectors for enclosed space,
- bunkering system ESD indication,
- inerting and purging system connections,
- pressure relieving system for the Bunkering manifold.

## 2.7 LNG transfer system

### 2.7.1 (1/12/2020)

A LNG transfer system is a system used to connect the LNG bunker ship and the receiving ship in order to transfer LNG or both LNG and vapours.

The LNG transfer system includes:

- loading arms and transfer hoses, as applicable
- manifold including valves and instrumentation,
- QCDC,
- breakaway coupling (BRC) or Emergency release coupling (ERC),
- isolation flanges.

## 2.8 MID

### 2.8.1 (1/12/2020)

Measuring Instruments Directive (MID). The Measuring Instruments Directive (MID) for Custody Transfer metering for liquids, is the European directive law that sets down the essential requirements for a wide range of measuring instruments. It provides options for the manufacturer as to how the requirements are met and which organizations to apply to for conformity assessment.

## 2.9 OIML R117-1

### 2.9.1 (1/12/2020)

OIML R117-1 is a recommendation issued by the ORGANISATION INTERNATIONALE DE METROLOGIE LEGALE (OIML). The International Organization of Legal

Metrology (OIML) is a worldwide, intergovernmental organization whose primary aim is to harmonize the regulations and metrological controls applied by the national metrological services, or related organizations, of its Member States. R117-1 addresses the Dynamic measuring systems for liquids other than water.

## 2.10 Pendant

### 2.10.1 (1/12/2020)

Pendant (for ESD system) is a portable device provided by one ship to another ship or shore terminal or provided by the shore to the ship for the manual tripping of its ESD system by the other party in the absence of a compatible ship-ship link (SSL).

## 2.11 Quick connect and disconnect coupling (QCDC)

### 2.11.1 (1/12/2020)

A QCDC is a manual or powered mechanical device used to connect the LNG transfer system to the receiving ship manifold. The coupling consists of a Nozzle (male) and a receptacle (female). The nozzle allows quick connection and disconnection of the fuel supply hose to the receptacle, mounted on the LNG manifold.

## 2.12 Safety zone

### 2.12.1 (1/12/2020)

The safety zone is a zone around the LNG bunker ship, the bunkering station of the receiving ship and the LNG transfer system, where the only activities to be performed are the bunkering operations and related activities and where safety measures are taken to cope with a possible leakage of LNG or vapour.

## 2.13 Transfer arm

### 2.13.1 (1/12/2020)

Transfer arm refers to any system allowing supporting transfer hoses or rigid pipes during bunkering operations.

## 3 Document to be submitted

### 3.1 General

#### 3.1.1 (1/12/2020)

The drawings and related information to be submitted are listed in Sec 1, Table 2.

#### 3.1.2 (1/12/2020)

The operating manuals and procedures to be submitted are listed in Tab 2.

**Table 1 : Documents to be submitted (1/12/2020)**

No	A/I	Documents
1	A	Arrangement of the ship showing the location of the bunkering station and bunkering control station
2	I	Risk assessment report including operational constraints for the bunkering operation such as minimum visibility, day/night, maximum wind and wave, weather condition.
3	I	List of all bunkering equipment with their technical specification (including hoses)
4	A	Details of LNG transfer system and vapor return line system
5	A	Purging and Inerting system supplying inert gas to the bunker station and bunkering equipment
6	I	Custody Transfer Measuring Instruments system (Including evidence of approval according to MID or OIML R117-1 requirements)
7	A	ESD Bunkering Concept including cause and effect matrix
8	A	Block diagram of Control, Monitoring and Safety System
9	A	ESD link system (SSL) description and list of communication devices used for the bunkering operation with their specification
10	A	Drip trays and water curtain arrangement
11	I	Instrumentation list and relevant Safety certificates for electrical equipment located in hazardous areas and concerning the bunkering, where applicable
12	A	Drawings of transfer arm
13	I	Fender and mooring arrangement for bunkering operation with mooring analysis
14	A	Bunkering station manifold specification and drawings, with strength calculation including values of maximum allowable working pressure and allowable loads at manifold flange
15	A	Access and walkway arrangement to bunkering station
<b>Note 1:</b> A = to be submitted for approval I = to be submitted for information		

**Table 2 : Operating manuals and procedures to be submitted (1/12/2020)**

No	A/I	Documents
1	I	Operational manual including bunkering procedure (with details of maximum allowable bunkering flow and maximum allowable working pressure), all information required in IGF Code 18.4.2 and IGC Code 18.2 and procedure for the boil off gas and vapour return management
2	I	Bunkering Safety Checklist according to IGF Code 18.4.3
3	I	Safety Zones Layout for the bunkering operation
4	I	Maintenance and storage instruction manual for the bunkering equipment
<b>Note 1:</b> A = to be submitted for approval I = to be submitted for information		

## 4 General design requirements

### 4.1 Risk Assessment

#### 4.1.1 LNG transfer system (1/12/2020)

A risk assessment shall be conducted according to IGC Code 1.1.11 and IGF Code 4.2 as far as applicable.

The goal of the risk assessment is to identify all safety, environmental and asset hazards associated to the LNG

Transfer system during bunkering operation and their possible mitigation where required. The risk analysis can be of qualitative or semi-quantitative type and shall be based on international recognized standards and Tasneef Guide for Risk Analysis.

#### 4.1.2 (1/12/2020)

The risk assessment is to be performed using the most appropriate techniques such HAZID (Hazards Identification) , FMEA (Failure Mode and Effect Analysis) or

HAZOP (Hazard and Operability study) as far as applicable and at least the following items shall be assessed:

- Bunkering station including manifold arrangement
- ESD Bunkering System
- Bunkering Equipment
- ESD Link system (SSL)
- Voice communication System between LNG bunker ship and receiving ship
- Monitoring, Control and Safety System of bunkering operation
- Fender and mooring arrangement

taking into account the following operations:

- Arrival, approach and mooring of LNG bunker ship close to the receiving ship
- Connection and testing of LNG transfer system including ESD system and communication link
- LNG bunkering procedure (including hose handling, hose connection, gassing up, cooling down)
- LNG bunkering in parallel with other activities (SIMOPs)
- Disconnection of the LNG bunker hose in normal and emergency condition (including draining, purging and inerting).

#### 4.1.3 (1/12/2020)

The SIMOPs shall be defined with reference to international recognized standards or guidelines such as IACS Rec. 142, SGMF FP08-01 "Simultaneous Operations (SIMOPS) during LNG Bunkering" and other activities identified by the risk assessment experts considering the expected port operations of the receiving ship.

## 4.2 Hazardous area

### 4.2.1 General (1/12/2020)

In general, safety and security zones are to comply with IACS Rec. 142, Section 2 and they are to be addressed during the risk assessment for the LNG bunkering operation.

### 4.2.2 (1/12/2020)

In addition to the hazardous areas in accordance with IGC Code, the following are to be included:

- LNG bunkering station and 3 m beyond these, up to a height of 2,4 m above the deck
- areas on the open deck within spillage coamings surrounding LNG bunkering connections and manifold valves and 3 m beyond these, up to a height of 2,4 m above the deck
- when applicable, transfer arm operating area extended by 3 m on either direction.

## 4.3 Materials

### 4.3.1 (1/12/2020)

Materials used in LNG transfer systems, piping system for liquefied gas and other systems or components in contact with LNG or gas are to be in accordance with IGC Code, Chapter 6.

## 4.4 Arrangement of bunkering system

### 4.4.1 LNG bunkering station (1/12/2020)

The LNG bunkering station is to be located on open deck so that sufficient natural ventilation is provided. Closed or semi-enclosed bunkering stations will be subject to special consideration and are subject to risk assessment as specified in [4.1]. Access to closed or semi-enclosed bunkering station from other closed or semi-enclosed space shall be granted via airlock.

The LNG bunkering station when not located in the cargo area shall be separated from accommodation and control stations through gas tight divisions and the layout is subject to risk assessment.

LNG bunkering station may be accepted at the ship bow and stern provided that the relevant requirements of IGC Code 3.8 are complied with.

The maximum allowable loads are to be indicated on a warning plate fitted on the manifold or nearby.

The manifold shall be arranged at least with the following instruments and fittings:

- Pressure gauge
- Pressure transmitter
- Temperature gauge
- Temperature transmitter
- Sampling point for gas detection
- Safety relief valve fitted in between the presentation flange and ESD bunkering valve.

### 4.4.2 Drip trays and protection of ship hull (1/12/2020)

Drip trays are to be fitted below the liquid bunkering connections and where leakage may occur which can cause damage to the ship structure.

Thermal sensors are to be positioned in the drip trays.

The drip trays are to be made of stainless steel and can be drained overboard.

When LNG boiling point at atmospheric pressure is lower than design temperature of the hull steel, a water piping system is to be fitted, providing a low-pressure water curtain in way of the hull under the bunkering manifold for additional protection of the hull steel and the ship's structure; other solutions will be considered on a case by case basis.

The operating platforms in way of the manifold operating position are to be fitted with raised gratings made of a material suitable for the LNG boiling point at atmospheric pressure.

### 4.4.3 Bunkering control station (1/12/2020)

Control of the bunkering operation should be possible from a bunkering control station that is placed in a safe location with regards to bunkering operations. The bunkering control station may be within the cargo control room. At this location, overfilling alarm and automatic and manual shutdown are to be indicated.

Unobstructed direct or camera view of the LNG bunkering station is to be available from the Bunkering control station.

An LNG system schematic/piping and instrumentation diagram (P&ID) shall be reproduced and permanently mounted in the bunkering control station.

#### 4.4.4 LNG Transfer Systems (1/12/2020)

The manifold for transfer of liquid shall be fitted with manually operated stop valve and a remotely/automatically operated valve (ESD valve) fitted in series.

The LNG transfer system is to include at least an emergency release coupling (ERC) and an insulation flange. A Quick Connect Disconnect Coupling (QCDC) may be installed together with above mentioned components.

The ERC is to be fitted on the receiving ship side, but may be accepted also fitted on LNG transfer system side provided that the relevant scenario is considered during the risk analysis required in [4.1].

In case the ERC is fitted on the LNG transfer system side, the nearest pressure relief valve on the receiving ship shall have sufficient capacity to accommodate the trapped liquid in the bunkering hose or pipe.

The hoses are to be adequately supported and protected to prevent potential damage or sparks in the event of activation of the ERC.

The manifolds are to be capable to withstand the allowable loads as defined in an international recognized standard or guideline such as SGMF TGN-06-04 "Technical Guidance Manifold" or equivalent.

The LNG transfer system is to be designed to avoid the release of gas to the atmosphere during bunkering operations.

The bunkering transfer rate is to be capable of being controlled to match with the capabilities and requirements of the receiving ship.

The maximum LNG transfer rate is to be declared and justified, taking into consideration:

- The management of the BOG generated during bunkering operation
- The temperature of the LNG supplied to the ship
- The maximum flow permitted by the ERC and or break away coupling
- The maximum flow permitted by the hose
- The maximum flow permitted by the QCDC
- The maximum allowable working pressure of the receiving ship bunkering station.

The GAS/LNG velocity in the piping system is not to exceed 10 m/s in order to avoid the generation of static electricity and to limit the heat transfer due to friction inside the pipes; higher velocity may be considered provided they are duly justified.

In order to prevent cryogenic liquid spills, the design of the transfer system is to be such that the lines can be drained and purged by nitrogen after a normal or emergency disconnection.

Any pipeline or component containing liquid, which may be isolated due to the ESD activation, is to be provided with pressure relief valve.

#### 4.4.5 LNG Bunkering ESD system (1/12/2020)

A bunkering ESD system is to be installed in addition to the ESD required by IGC Code, if a separate transfer system is provided.

All electrical components of the ESD systems are to be of suitable safe type taking into account the hazard categorization of the area where they are located.

#### 4.4.6 Lighting (1/12/2020)

Lighting shall illuminate the bunker station area, and if installed in a hazardous area should be compliant with applicable hazardous area equipment requirements. Lighting shall adequately illuminate the bunkering operation work area as follows:

- LNG bunker hose(s),
- Connection and couplings on both receiving ship and bunkering facility,
- ESD system call points,
- Communication systems,
- Fire-fighting equipment,
- Passage ways / gangways intended to be used by the personnel in charge of the bunkering operation, and
- Vent mast(s).

### 4.5 Mooring and fendering

#### 4.5.1 (1/12/2020)

Steel to steel contact between LNG bunker ship and receiving ship e.g. via mooring lines, ladders, gangways, chains for fender support etc. shall be avoided through the use of insulation. Bunker hoses/pipes shall be supported and isolated to prevent electrical contact with the receiving ship.

#### 4.5.2 (1/12/2020)

The rubber fenders used for keeping the distance between the LNG bunkering ship and receiving ship shall be built according to an international recognized standard such as ISO 17357-2 or equivalent. The dimensions and arrangement of fenders shall be verified during risk assessment as required in [4.1] taking into consideration the interferences of the hazardous areas of both ships and the minimum bend radius of the bunkering hose.

## 5 Hoses and pumps

### 5.1 Hose design requirements

#### 5.1.1 General (1/12/2020)

The hoses used for bunkering are to comply with the requirements in IGC Code 5.11.7.

For bunkering hoses the following characteristics are to be defined by the designer and submitted to the Society:

- Minimum/Maximum Allowable Working Temperature
- Maximum Allowable Working Pressure
- Minimum Bend Radius
- Maximum Allowable Crush Load
- Maximum Allowable Axial Load.

### 5.1.2 Hose Maximum Working Pressure and Strength (1/12/2020)

The maximum working pressure specified by manufacturer is not to be less than 1 MPa in accordance with IGC Code 5.11.7.3.

The strength of the hoses is to be compatible with the maximum release forces of the ERC.

### 5.1.3 Materials (1/12/2020)

All materials of hose assembly are to be suitable for marine environment, compatible with each other and with the fluid conveyed (LNG and LNG vapours).

### 5.1.4 End connection and coupling (1/12/2020)

The end fittings are to be made of corrosion resistant material and in accordance with IGC Code Table 6.4.

## 5.2 Type approval, testing and certification of LNG bunkering hoses

### 5.2.1 (1/12/2020)

Bunkering hoses are to be type approved by the Society.

Flexible hoses intended for the handling of LNG are to be in compliance with design and testing requirements standards EN1474-2, or EN21012 or equivalent standards and IGC Code 5.11.7.

### 5.2.2 (1/12/2020)

All hoses are to be individually certified by the Society at satisfactory outcome of testing according to [5.3], carried out by the manufacturer in the presence of a Society Surveyor, unless an alternative certification scheme is agreed with the Society.

## 5.3 Testing of Hoses at workshop

### 5.3.1 Pressure test (1/12/2020)

Each hose assembly is to be subjected to a hydraulic pressure test at ambient temperature to a pressure not less than 1,5 times the maximum operating (nominal) pressure, to demonstrate that the hose assembly is capable of withstanding pressure without leaking.

### 5.3.2 Non destructive testing of welding (1/12/2020)

Welds of the hose assembly are to be subjected to non destructive testing (NDT) according to international recognized standards.

## 5.4 Hoses documentation

### 5.4.1 (1/12/2020)

A hose technical file containing the following information is to be kept on board:

- Hose identification number
- Type approval certificate issued by Society
- Product test certificate issued by Society
- Overall weight of the hose and end fittings assembly
- Date of entry into service
- Inspection intervals and lifetime
- Instructions for the handling, storage and installation of hose

## 5.5 Marking of products

### 5.5.1 (1/12/2020)

Each hose is to be permanently marked according to a recognized international standard or the following information:

- Manufacturer's name or logo
- Hose designation and size
- Maximum Allowable Working Pressure
- Maximum and minimum allowable working temperature
- Date of manufacture
- Marking from Society

## 5.6 Transfer pumps

### 5.6.1 (1/12/2020)

The transfer pumps if different from cargo pumps shall comply with requirements specified in Sec 5, [3.2] and they shall be type approved.

All pumps are to be pressure tested in the presence of the Surveyor.

## 6 Quick connect disconnect coupler (QCDC)

### 6.1 Type approval, testing and certification of QCDC

#### 6.1.1 (1/12/2020)

QCDC are to be type approved by the Society.

#### 6.1.2 (1/12/2020)

All QCDC are to be individually certified by the Society at satisfactory outcome of testing according to [6.3] carried out by the manufacturer in the presence of the Surveyor, unless an alternative certification scheme is agreed with the Society.

### 6.2 Type testing

#### 6.2.1 (1/12/2020)

The QCDC is to be subjected to a type test to confirm the release performance under ice built up condition according to an international recognized standard such as ISO 21593, ISO 16904 or equivalent.

### 6.3 Workshop testing

#### 6.3.1 Pressure test (1/12/2020)

The QCDC is to be subjected to a hydrostatic pressure test, at ambient temperature, to a pressure not less than 1,5 times the Maximum Allowable Working Pressure to demonstrate that the QCDC is capable of withstanding pressure without leakage.



## 7 Emergency release coupling (ERC)

### 7.1 Type approval, testing and certification of QCDC

#### 7.1.1 General (1/12/2020)

Transfer arms and hoses shall be fitted with an emergency release coupling (ERC) designed to minimize the release of LNG on emergency disconnection. The emergency release coupling is to be designed as breakaway coupling i.e. with automatic disconnection in case the allowable loads of manifold as defined in [4.4.4] are exceeded. Additionally the emergency release coupling may be designed with manual or remote and automatic activation by the ESD bunkering system.

#### 7.1.2 (1/12/2020)

Each separate section is to contain a self-closing shut-off valve, which seals automatically on disconnection.

#### 7.1.3 (1/12/2020)

All electrical components of the emergency release coupling are to be certified of a suitable safe type.

When applicable, the availability of power to the ERC is to be monitored and arranged so that bunkering operation is automatically stopped in case of loss of power supply to the ERC.

#### 7.1.4 (1/12/2020)

The bunkering line is to be designed and arranged to withstand the surge pressure that may result from the activation of the ERC.

### 7.2 Type approval, testing and certification of ERC

#### 7.2.1 (1/12/2020)

ERC are to be type approved by the Society.

#### 7.2.2 (1/12/2020)

All ERCs are to be individually certified by the Society at satisfactory outcome of testing according to [7.4] carried out by the manufacturer in the presence of a Society Surveyor, unless an alternative certification scheme is agreed with the Society.

### 7.3 Type testing

#### 7.3.1 (1/12/2020)

The ERC are to be subjected to a type test according to an international recognized standard such as ISO 18683 or equivalent to confirm the values of axial and shear forces at which it automatically separates. Additionally the tightness of the self-closing shut-off valves after separation is to be tested.

#### 7.3.2 (1/12/2020)

The ERC are to be subjected to a type test to confirm the release performance under ice built up condition.

#### 7.3.3 (1/12/2020)

When applicable, the ERC is to be subjected to a type test to confirm the release in case of remote or automatic activation.

## 7.4 Workshop testing

### 7.4.1 Pressure test (1/12/2020)

The ERC are to be subjected to a hydrostatic pressure test, at ambient temperature, to a pressure not less than 1,5 times the Maximum operating (nominal) pressure, to demonstrate that the ERC are capable of withstanding pressure without leaking.

## 8 Electrical insulation flanges

### 8.1 General

#### 8.1.1 (1/12/2020)

Each insulation flange is to be subjected to a test of electrical resistance in air and the resistance is to be of at least 1000  $\Omega$  but less than 1 M $\Omega$ .

#### 8.1.2 (1/12/2020)

The resistance of each insulation flange is to be measured after installation in the complete LNG transfer system and the resistance is to be not less than 1000  $\Omega$ .

## 9 Hose Supports and transfer arms

### 9.1 General

#### 9.1.1 (1/12/2020)

Hoses are to be suitably supported in such a way that the minimum allowable bending radius is complied with.

#### 9.1.2 (1/12/2020)

Arrangements such as cranes or winches are to be available for the handling of hoses whose size or weight does not allow a safe manual handling.

#### 9.1.3 (1/12/2020)

Non electrical equipment located in hazardous area and belonging to items such as cranes, winches, etc. is to be suitable for explosive atmosphere according to international recognized standard (e.g. ISO 80079-36 or equivalent).

#### 9.1.4 (1/12/2020)

Electrical equipment located in hazardous area is to comply with IGC Code 10.2.

### 9.2 Transfer arms

#### 9.2.1 (1/12/2020)

Transfer arms are to be approved by the Society.

#### 9.2.2 (1/12/2020)

Transfer arms are to be designed and constructed in accordance with a recognized national or international standards acceptable to the Society as EN1474-1.

#### 9.2.3 (1/12/2020)

The maximum allowable operating amplitude and forces acting on the loading arm during the bunkering operations are to be defined and compatible with the hoses and ERC. The exceeding of transfer arm envelope is to activate two stages alarms in bunker control station and on the navigation bridge.

The initiation of the first stage is to activate a visual and audible alarm.

The initiation of the second stage is to activate the ESD and ERC system.

#### **9.2.4 (1/12/2020)**

All transfer arms are to be individually certified by the Society at satisfactory outcome of tests, as required for lifting appliances and operational tests, or per recognized international standards, carried out by the manufacturer in the presence of a Society Surveyor, unless an alternative certification scheme is agreed with the Society.

#### **9.2.5 (1/12/2020)**

The operational test per [9.2.4] is to give evidence of compliance with the design criteria per [9.2.3].

## **10 Inert Gas System**

### **10.1**

#### **10.1.1 (1/12/2020)**

An inert gas system is to be fitted on board, to enable purging and inerting of the bunkering lines; the system is to be in compliance with IGC Code 9.4 and 9.5.

#### **10.1.2 (1/12/2020)**

The inerting capacity is to be designed according the bunkering operations and when based on inert gas storage on board, the capacity is not to be less than 5 times the volume of the hose and pipes to be purged.

## **11 Gas detection**

### **11.1 Gas detection in enclosed spaces**

#### **11.1.1 (1/12/2020)**

Permanently installed gas detectors are to be fitted in all hazardous areas including bunkering station if of enclosed or semi-enclosed type, LNG process room and other enclosed spaces containing LNG piping or other equipment not equipped with double walled piping.

#### **11.1.2 (1/12/2020)**

The number of detectors in each space is to be considered taking into account the size, layout and ventilation of the space. At least two independent gas detectors are required in each hazardous area.

#### **11.1.3 (1/12/2020)**

The detection equipment is to be located where gas may accumulate and in the ventilation outlets. Gas dispersion analysis or a physical smoke test is to be used to find the best arrangement.

#### **11.1.4 (1/12/2020)**

An audible and visual alarm is to be activated before the vapour concentration reaches 30% of the lower explosive limit (LEL).

#### **11.1.5 (1/12/2020)**

Audible and visual alarms from the gas detection equipment are to be located on the bridge and in the bunkering control station.

### **11.2 Gas detection in open spaces**

#### **11.2.1 (1/12/2020)**

The installation of thermal imaging camera is to be evaluated on the basis of the risk assessment as defined in [4.1], for open spaces classed as hazardous areas (e.g. bunkering station, hose handling areas).

Monitoring of thermal imaging camera is to be available in the bunkering control station.

## **12 Control and safety systems**

### **12.1 General**

#### **12.1.1 (1/12/2020)**

Appropriate segregation shall be maintained between control, monitoring/alarm and safety functions to limit the effects of single failures during bunkering.

Failure of one part of the integrated system shall not affect the functionality of other parts, except for those functions directly dependent on the defective part.

Being the bunkering control system combined with the cargo control system all relevant requirements specified in the IGC Code 13.9 are to be complied with.

### **12.2 Emergency shut-down systems (ESD)**

#### **12.2.1 (1/12/2020)**

An ESD system is to be fitted to safely and effectively stop the transfer of LNG (and vapour as applicable) between the receiving ship and the bunkering ship in the event of an emergency during the bunkering operation and in general it is to be in compliance with IGC Code 18.10.

The ESD safety system is to be designed so as to limit the consequence of failures. It is to be constructed on the fail-to safety principle.

The ESD system is to be of the self-check type; as a rule, failure within the ESD including the outside connection, is to activate an alarm.

The control systems involved in the ESD, which is a linked system to allow both parties (on board receiving ship and the LNG bunkering ship) to shut down the transfer in an emergency situation, is to be capable of being activated automatically or manually.

The ESD system normally includes two stages:

- ESD-stage 1, a stage in which the LNG transfer process is shut down in a controlled manner
- ESD-stage 2, a stage in which decoupling of the transfer system between the transfer vessels or between a vessel and an LNG port facility is activated.

The ESD-1 and ESD-2 logic shall be verified and agreed among stakeholders during the risk assessment as required in [4.1] also considering applicable international recognized standard or guidelines (e.g. SIGTTO ESD Arrangements & Linked Ship/Shore Systems for Liquefied Gas Carriers).

Where provided, override command of ESD system has to be clearly indicated in the Bunkering control station.

The ESD-1 and ESD-2 trips are to trigger visual and audible alarms in the navigation bridge, engine control room, cargo and bunkering control room and manifold area.

#### 12.2.2 (1/12/2020)

At least one local manual activation position for the ESD system is to be made available for the LNG fueled ship being bunkered, this may be in the form of an ESD System pendant with sufficient length of cable or an ESD link system (SSL ship/shore link or ship/ship link). The SSL may be various type (e.g.: electric, fibre-optic, radio telemetry, pneumatic). The SSL is to have an adequate reliability and redundancy level according to a recognized international standard or guideline (e.g.: SIGTTO ESD Arrangements & Linked Ship/Shore Systems for Liquefied Gas Carriers).

#### 12.2.3 (1/12/2020)

At least one local manual activation position for the ESD system is to be fitted in a place that have a clear view of the manifold area (the 'clear view' may be provided via CCTV) but is at a safe distance from the manifold.

#### 12.2.4 (1/12/2020)

Any activation of the ESD systems is to be implemented simultaneously on both bunkering facility and receiving ship.

#### 12.2.5 (1/12/2020)

The timing sequence is to ensure that the involved pumps and compressors (if any) stop before the complete closure of any manifold valve.

#### 12.2.6 (1/12/2020)

The bunkering lines are to be designed and arranged to withstand the surge pressure that may result from the activation of the emergency release coupling and quick closing of ESD valves. If not demonstrated to be required at a higher value due to pressure surge considerations, a default time of 5 seconds from the trigger of the alarm to full closure of the ESD valves is to be arranged.

#### 12.2.7 (1/12/2020)

The components of the ESD system located in hazardous and safety zones are to be of a suitable safe type.

#### 12.2.8 (1/12/2020)

LNG bunker transfer should not be resumed until the transfer system and associated safety systems (fire detection, etc.) are returned to normal operation condition.

#### 12.2.9 (1/12/2020)

All electrical components of the emergency release coupling actuator and of the ESD systems that are provided by the LNG bunkering ship are to be approved and certified by the Society.

### 12.3 Alarms and safety actions

#### 12.3.1 (1/12/2020)

The alarms and safety function/actions required for the transfer system are given in Tab 3 and they are additional to those required in the IGC Code Table 18.1 . The extent of alarms and safety functions may be reconsidered on the basis of outcome from risk assessment.

The receiving ship is expected to be capable of transmitting at least an ESD signal via an hardwired system.

**Table 3 : Alarms and safety actions required for the transfer system (1/12/2020)**

Parameters	Alarm	Activation of the Bunker ESD systems (ESD-1)	Automatic activation of the emergency release coupling (ESD-2) (1)
Fire Detection in way of tank domes or manifold area for receiving ship and LNG bunker ship (1)	X	X	
Shutdown signal from shore or receiving ship	X	X	
Loss of ESD linked system (1)	X	X	
Loss of power supply to LNG bunkering control system	X	X	
ESD logic failure	X	X	
Low Pressure in cargo valve remote control system	X		
Low Low Pressure in cargo valve remote control system	X	X	
Stop of the ventilation of enclosed or semi-enclosed bunkering station	X	X	
Loss of actuating power to the common loading arm maneuvering system or to the ERC of individual loading arms	X	X	
High level in surge drum (where provided)	X		
High High level in surge drum (where provided)	X	X	
Low pressure in the supply cargo tank	X		
Low Low pressure in the supply cargo tank	X	X	
(1) when the receiving ship is equipped with an SSL compatible with the LNG bunkering ship SSL			

Parameters	Alarm	Activation of the Bunker ESD systems (ESD-1)	Automatic activation of the emergency release coupling (ESD-2) (1)
Sudden pressure drop at the transfer pump discharge	X	X	
High level in the LNG storage tank of receiving ship (1)	X		
High High level in the LNG storage tank of receiving ship (1)	X	X	
High pressure in the LNG storage tank of receiving ship (1)	X		
High High pressure in the LNG storage tank of receiving ship (1)	X	X	
High pressure in the manifold vapor return system	X		
High high pressure in the manifold vapor return system	X	X	
High pressure in the manifold liquid supply system	X		
High High pressure in the manifold liquid supply system	X	X	
LNG cold leakage in the manifold drip tray	X	X	
Gas detection in bunkering station of receiving ship (1)	X	X	
Gas detection in bunkering station of bunkering ship	X	X	
Excessive movement of ship from berth/ship	X	X	X
Disconnection of the ERC	X	X	
(1) when the receiving ship is equipped with an SSL compatible with the LNG bunkering ship SSL			

## 12.4 Communication systems

### 12.4.1 (1/12/2020)

A two-way voice communication system is to be provided between the LNG bunker ship and the receiving ship.

### 12.4.2 (1/12/2020)

The components of the communication system located in hazardous and safety zones are to be of a suitable safe type.

## 13 Testing of the LNG transfer system at workshop

### 13.1 Pressure test

#### 13.1.1 (1/12/2020)

All piping and tanks the LNG transfer system are to be subjected to a hydraulic pressure test in the presence of a Society Surveyor, at ambient temperature, to a pressure not less than 1,5 times the nominal pressure, to demonstrate the capability to withstand pressure without leaking.

### 13.2 Inspection of welds

#### 13.2.1 (1/12/2020)

When applicable, the welds of the LNG transfer system are to be subjected to a non-destructive testing and all butt welds are to be subjected to a 100% radiographic or ultrasonic examination.

## 14 Testing and trials of the LNG transfer system at yard

### 14.1

#### 14.1.1 (1/12/2020)

After assembly on board, the following tests and trials are to be carried out in the presence of a Surveyor.

### 14.2 Piping leak test

#### 14.2.1 (1/12/2020)

A leak test, using air or other suitable medium, of the completely assembled and equipped LNG transfer and vapour return systems, in steps of 10-20% up to 90% of the operational pressure of the LNG/gas system is to be carried out in the presence of a Society Surveyor, to detect leakage with soap/leak detection spray. Holding time is depending of the volume/part of the installation being Leak tested.

### 14.3 Inerting

#### 14.3.1 (1/12/2020)

Inerting of the total LNG/gas system including LNG storage tank(s), following the approved inerting procedure.

## 15 Implementation survey

### 15.1

#### 15.1.1 (1/12/2020)

Upon issuance of the additional service feature LNG bunker, a dedicated survey is to be carried out on occasion of the first LNG bunkering, as follows:

- a) The first LNG bunkering is to be carried out according to the relevant LNG bunkering procedure.
- b) During the survey the following is to be carried out:
  - Examination of transfer piping systems including supporting arrangements.
  - Verification of satisfactory operation of:
    - Control and monitoring systems
    - Connections systems (QCDC).
    - ESD system
    - piping purging and inerting systems.

## 16 Additional features

### 16.1 IG-Bunker (Inert Gas Bunker)

#### 16.1.1 General (1/12/2020)

The additional feature **IG-Bunker (Inert Gas Bunker)** is assigned to LNG bunker ship designed to also supply inert gas to a LNG fuelled ship to ensure inerting of the receiving ship systems, and complying with the following requirements.

#### 16.1.2 Inert Gas system (1/12/2020)

The inert gas system is to comply with IGC Code 9.4 and 9.5 and Chapter 9.

#### 16.1.3 Piping system (1/12/2020)

The lines used for the inert gas are to be independent from the LNG liquid and vapour lines used for normal operation.

#### 16.1.4 Document to be submitted (1/12/2020)

The following documents are to be submitted to the Society for approval in addition to the information required in [3]:

- Diagram of the Inert gas system
- Procedure for supplying inert gas to the receiving ship.

### 16.2 BT (Bunker Trust)

#### 16.2.1 General (1/12/2020)

The additional feature **BT (Bunker Trust)** is assigned to LNG bunker ship designed with arrangement for the verification of the LNG quality and quantity delivered to the receiving ship according to international recognized standard (e.g. ISO 23306) or equivalent or according to a gas fuel specification agreed among the stakeholders.

#### 16.2.2 Documents to be submitted (1/12/2020)

The following documents are to be submitted to the Society for approval in addition to the information required in [3]:

- Diagram of the LNG sampling arrangement
- Technical specification of LNG analyzer
- LNG Sampling procedure
- Evidence of approval of the measuring system according to MID or OIML R117-1.

#### 16.2.3 Sampling System (1/12/2020)

The ship has to be fitted with a sampling system in accordance with international recognized standard (e.g. ISO 8943) or equivalent. Other type of system or piping arrangement are subject to special consideration and they are evaluated case by case.

The sampling connections shall be in compliance with requirements specified in IGC Code 5.6.5 .

The sampling procedure shall be in compliance with requirements specified in IGC Code 18.9 and included in the risk assessment as required in [4.1.2].

The LNG analyzer is to be type approved.

#### 16.2.4 Custody Transfer Measuring System (1/12/2020)

A Custody Transfer Measuring System is to be installed on the LNG bunker ship.

A recognized third party should approve the design and instruments against MID or OIML R117-1; evidence of this is required to be supplied to the Society.

### 16.3 VCS-Bunker (Vapour Control System Bunker)

#### 16.3.1 General (1/12/2020)

The additional feature **VCS-Bunker (Vapour Control System Bunker)** is assigned to LNG bunker ship in compliance with Pt F, Ch 13, Sec 7 for the assignment of notation **VCS-Transfer**.

#### 16.3.2 Vapour return handling (1/12/2020)

The LNG bunker ship is to be capable of handling all or part of the vapours from receiving ship generated during the LNG bunkering operation, in addition to its own boil-off gas (BOG), without release to the atmosphere. The vapour handling capacity of the LNG bunker ship is to be indicated and justified.

Different ways to dispose of the vapours may be considered, such as:

- re-liquefaction
- utilization by the gas consuming equipment of the LNG bunkering ship (e.g. gas or dual-fuel engines or boilers)
- gas combustion unit.

A combination of these means is possible and other solutions may be accepted if they are duly justified to the Society.

## 16.4 NH3 Tank Ready and NH3 Tank

### 16.4.1 General (1/1/2024)

The additional features **NH3 Tank Ready** and **NH3 Tank** are assigned to LNG bunker ship:

- fitted with LNG cargo tanks designed also for ammonia storage (**NH3 Tank Ready**)
- fitted with LNG cargo tanks designed, built and tested also for ammonia storage (**NH3 Tank**).

### 16.4.2 NH3 Tank Ready (1/1/2024)

The drawings of the tank are to be verified considering both LNG and ammonia cargoes.

The protocol to be used for testing the tank material is to be submitted for information.

The applicable design criteria are to be documented and submitted by the tank manufacturer and will be specially considered by the Society on a case-by-case basis.

### 16.4.3 NH3 Tank (1/1/2024)

The drawings of the tank are to be verified considering both LNG and ammonia cargoes.

The documents related to the tests campaign carried out for the tank material are to be provided for review.

The applicable design criteria are to be documented and submitted by the tank manufacturer and will be specially considered by the Society on a case-by-case basis.

## APPENDIX 2

# REGASIFICATION SYSTEMS, PROCESS PRESSURE VESSELS AND LIQUID, VAPOUR AND PRESSURE PIPING SYSTEMS

## 1 Regasification systems

### 1.1 General

#### 1.1.1 (1/1/2021)

These are systems where the cargo is regasified from a liquid to a vapour and then sent ashore via a pipeline for use as a gaseous fuel. The vapour may or may not be treated on board the installation dependent on the requirements of the end user.

The vaporisers are to be selected to satisfy the heaviest demand of the end user and should be able to function during all motions of the installation.

Selection of the vaporisers is to consider environmental impact in terms of air emissions, use of biocides or changes in seawater temperature.

The availability of auxiliary systems serving the process system and on which the process system may depend is also to be considered in selection of design code and specification of such systems.

The design is to ensure that cross contamination of auxiliary systems with hydrocarbons will be adequately protected against.

### 1.2 Design and construction

#### 1.2.1 (1/1/2021)

The design and construction of regasification systems are to be in accordance with a recognized Standard and with the requirement of this section. The standards are to be adhered to in their entirety.

Use of other standards is subject to the approval by the Society.

### 1.3 Documentation to be submitted

#### 1.3.1 (1/1/2021)

Sec 1, Table 1 lists the plans, information, analysis, etc. which are to be submitted in addition to the information required in the other Parts of the Rules for the parts of the unit not affected by the cargo, as applicable.

**Table 1 : Documents to be submitted (1/1/2021)**

No.	A/I	Documents
1	A	Details of process pressure vessels and relative valving arrangement
2	I	Regasification system

## 2 Process pressure vessels

### 2.1

#### 2.1.1 (1/1/2021)

IGC CODE REFERENCE : Ch 5, 5.1.2

Process pressure vessels handling cargo are to be considered at least as class 2 pressure vessels, in accordance with Pt C, Ch 1, Sec 3, [1.4.1].

#### 2.1.2 (1/1/2021)

IGC CODE REFERENCE : Ch 5, 5.1

The maximum temperature of steam and heating media within the cargo area is to be adjusted to take into account the temperature class of the cargoes.

## 3 Regasification process piping

### 3.1

#### 3.1.1 Cargo import and export system (1/1/2021)

Provisions for cargo import and export systems are given in [5] too.

#### 3.1.2 Provisions for protection of piping against thermal stress (1/1/2021)

IGC CODE REFERENCE : Ch 5, 5.7.1

Expansion joints are to be protected from extensions and compressions greater than the limits fixed for them and the connected piping is to be suitably supported and anchored. Bellow expansion joints are to be protected from mechanical damage.

#### 3.1.3 Segregation of high temperature piping (1/1/2021)

IGC CODE REFERENCE : Ch 5, 5.7.2

High temperature pipes are to be thermally isolated from the adjacent structures. In particular, the temperature of pipelines is not to exceed 220 °C in gas-dangerous zones.

#### 3.1.4 Pressure relief valve setting (1/1/2021)

IGC CODE REFERENCE : Ch 5, 5.5.6 and 5.5.7

Pressure relief valves are to be set to discharge at a pressure not greater than the design pressure such that the overpressure during discharge does not exceed 110% of the design pressure.

#### 3.1.5 Protection against leakage (1/1/2021)

IGC CODE REFERENCE : Ch 5, 5.2

Where the piping system is intended for liquids having a boiling point lower than - 30 °C, permanent means to avoid

possibility of contact between leaks and hull structures are to be provided in all those locations where leakage might be expected, such as shore connections, pump seals, flanges subject to frequent dismantling, etc.

### 3.1.6 Means for detecting the presence of liquid cargo (1/1/2021)

IGC CODE REFERENCE : Ch 5, 5.2

The means to detect the presence of liquid cargo may be constituted by electrical level switches whose circuit is intrinsically safe. The alarm signals given by the level switches are to be transmitted to the wheelhouse and to the cargo control station, if provided.

### 3.1.7 Connections of relief valve discharges to cargo tanks (1/1/2021)

IGC CODE REFERENCE : Ch 5, 5.2

The connections, if any, to the cargo tanks of relief valve discharges fitted on the liquid phase cargo piping are not to be fitted with shut-off valves, but are to be provided with non-return valves in the proximity of the tanks.

### 3.1.8 Centrifugal pumps (1/1/2021)

IGC CODE REFERENCE : Ch 5, 5.2

Overpressure relief valves on cargo pumps may be omitted in the case of centrifugal pumps having a maximum delivery head, the delivery valve being completely closed, not greater than that permitted for the piping.

## 3.2 Design pressure

### 3.2.1 Design pressure definition (1/1/2021)

IGC CODE REFERENCE : Ch 5, 5.4.1

For each piping section, the maximum pressure value among those applicable in paragraph 5.11.2.2 of the IGC Code is to be considered.

## 3.3 Flanges

### 3.3.1 Flanges not complying with standards (1/1/2021)

IGC CODE REFERENCE : Ch 5, 5.11.6.2

For flanges not complying with a standard, the dimensions and type of gaskets are to be to the satisfaction of the Society.

## 3.4 Stress analysis

### 3.4.1 Calculations in accordance with recognised standards (1/1/2021)

IGC CODE REFERENCE : Ch 5, 5.11.5

When such an analysis is required, it is to be carried out in accordance with the requirements listed below. Subject to this condition, calculations in accordance with recognised standards are accepted by the Society.

### 3.4.2 Calculation cases (1/1/2021)

IGC CODE REFERENCE : Ch 5, 5.11.5

The calculations are to be made for every possible case of operation, but only those leading to the most unfavourable results are required to be submitted.

### 3.4.3 Loads to be taken for calculation (1/1/2021)

IGC CODE REFERENCE : Ch 5, 5.11.5

The calculations are to be carried out taking into account the following loads:

- a) piping not subject to green seas:
  - pressure
  - weight of the piping and of the internal fluid
  - contraction
- b) piping subject to green seas that is liable to be in operation at sea and in port:
  - pressure
  - weight of the piping and of the internal fluid
  - green seas
  - contraction
  - unit motion accelerations
- c) piping subject to green seas that is in operation only in port; the more severe of the following two combinations of loads:
  - pressure
  - weight of the piping and of the internal fluid
  - contraction
  - weight of the piping
  - green seas
  - expansion, assuming that the thermal stresses are fully relaxed.

### 3.4.4 Green sea directions (1/1/2021)

IGC CODE REFERENCE : Ch 5, 5.11.5

When green seas are considered, their effects are to be studied, unless otherwise justified, in the following three directions:

- axis of the unit
- vertical
- horizontal, perpendicular to the axis of the unit.

### 3.4.5 Stress intensity (1/1/2021)

IGC CODE REFERENCE : Ch 5, 5.11.5

The stress intensity is to be determined as specified in the formulae in Pt C, Ch 1, Sec 10, [2.3.2] for pipes intended for high temperatures:

- a) for primary stresses resulting from:
  - pressure
  - weight
  - green seas
- b) for primary stresses and secondary stresses resulting from contraction.

### 3.4.6 Stress intensity limits (1/1/2021)

IGC CODE REFERENCE : Ch 5, 5.11.5

- a) For the first case, the stress intensity is to be limited to the lower of:  
0,8  $R_e$  and 0,4  $R_m$
- b) for the second case, the stress intensity is to be limited to the lower of:  
1,6  $R_e$  and 0,8  $R_m$ .



**3.4.7 Piping with expansion devices (1/1/2021)**

IGC CODE REFERENCE : Ch 5, 5.11.5

For piping fitted with expansion devices, their characteristics are to be submitted to the Society. Where these characteristics are such that the forces and moments at the ends of the devices are negligible for the contraction they must absorb, the calculation of the loads due to contraction in the corresponding piping is not required. It is, however, to be checked that the stress intensity corresponding to the primary stresses does not exceed the limits given in [3.4.6].

**3.4.8 Flexibility coefficient (1/1/2021)**

IGC CODE REFERENCE : Ch 5, 5.11.5

The flexibility coefficient of elbows is to be determined from the formulae given in Pt C, Ch 1, Sec 10, [2.3.2] for pipes intended for high temperatures.

**3.4.9 Local stresses (1/1/2021)**

IGC CODE REFERENCE : Ch 5, 5.11.5

Particular attention is to be paid to the calculation of local stresses in the assemblies subjected to axial forces and bending moments. The Society reserves the right to request additional justifications or local strengthening where considered necessary.

**3.5 Aluminised pipes****3.5.1 (1/1/2021)**

IGC CODE REFERENCE : Ch 5, 5.12

Aluminised pipes may be fitted in ballast tanks, in inerted cargo tanks and, provided the pipes are protected from accidental impact, in hazardous areas on open deck.

**4 Cargo system valving requirements****4.1 Cargo tank connections for gauging****4.1.1 Exemption (1/1/2021)**

IGC CODE REFERENCE : Ch 5, 5.5.5

The requirements in paragraph 5.5.5 of the IGC Code relevant to cargo tank connections for pressure gauges and measuring devices do not apply to tanks with an MARVS not exceeding 0,07 MPa.

**4.2 Emergency shutdown****4.2.1 Clarification on location of fusible elements (1/1/2021)**

IGC CODE REFERENCE : Ch 18, 18.10

The cargo stations in way of which the fusible elements mentioned in paragraph 18.10.3.2 of the IGC Code are to be fitted are to be intended as the loading and unloading manifolds.

The system may be integrated into the fire and gas systems and appropriate level of redundancy based on risk analysis in these locations.

The need to enhance the reliability of the system and of process shutdowns may require the use of different

technologies for this system or the use of voting duplicated systems.

**4.2.2 Fail-close action of Emergency Shut Down (ESD) valve (1/1/2024)**

IGC CODE REFERENCE : Ch 18, 18.10.2.1.2

The following requirements specify the arrangements for emergency shut down valve (hereinafter referred to as ESD valve) installed in cargo piping of ships engaged in the carriage of liquefied gases to stop cargo flow in the event of an emergency, either internally within the ship, or during cargo transfer to other ships or shore facilities.

When ESD valve is actuated by hydraulic or pneumatic system, the following are to be complied with:

- a) audible and visible alarm is to be given in the event of loss of pressure that causes activation of fail-close action. The alarm is to be provided in a normally manned control station (e.g. Cargo Control Room and/or the navigation bridge, etc.).
- b) the following conditions are also to be complied to ensure the fail-close action:
  - 1) failure of hydraulic or pneumatic system is not to lead to loss of fail-close functionality (i.e. activated by spring or weight); or
  - 2) hydraulic or pneumatic system for fail-close action is to be arranged with stored power and separated from normal valve operation.

**5 Cargo transfer methods****5.1 Discharge into common header****5.1.1 (1/1/2021)**

IGC CODE REFERENCE : Ch 5, 5.6

When two or more pumps located in different cargo tanks are operating at the same time discharging into a common header, the stop of the pumps is to activate an alarm at the centralised cargo control location.

Equipment for liquefied gas transfer (e.g. hoses, loading arms) is to be certified for its intended use.

**6 Bonding****6.1 Static electricity****6.1.1 Acceptable resistance (1/1/2021)**

IGC CODE REFERENCE : Ch 5, 5.7.4

To avoid the hazard of a discharge due to the build-up of static electricity resulting from the flow of the liquid/gases/vapours, the resistance between any point on the surface of the cargo and slop tanks, piping systems and equipment, and the hull of the unit is not to be greater than  $10^6 \Omega$ .

**6.1.2 Bonding straps (1/1/2021)**

IGC CODE REFERENCE : Ch 5, 5.7.4

Bonding straps are required for cargo and slop tanks, piping systems and equipment which are not permanently connected to the hull of the unit, for example:

- a) independent cargo tanks
- b) cargo tank piping systems which are electrically separated from the hull of the unit
- c) pipe connections arranged for the removal of the spool pieces.

Where bonding straps are required, they are to be:

- a) clearly visible so that any shortcoming can be clearly detected
- b) designed and sited so that they are protected against mechanical damage and are not affected by high resistivity contamination, e.g. corrosive products or paint
- c) easy to install and replace.

## 7 Materials for construction

### 7.1 Material requirements

#### 7.1.1 Tubes, forgings and castings for cargo and process piping (1/1/2021)

IGC CODE REFERENCE : Ch 6, Table 6.4

In general, impact tests for forgings, castings and welded and seamless pipes in stainless austenitic grades 304, 304L, 316, 316L, 321 and 347 are required when the design temperature is below -105°C and are to be carried out at -196°C.

#### 7.1.2 Aluminium coatings (1/1/2021)

IGC CODE REFERENCE : Ch 6, 6.4

The use of aluminium coatings is prohibited in the cargo tanks, cargo tank deck area, pump rooms, cofferdams or any other area where cargo gas may accumulate.

### 7.2 Welding and non-destructive testing

#### 7.2.1 Welding consumables (1/1/2021)

IGC CODE REFERENCE : Ch 6, 6.5.2.1

The content of paragraph 6.5.2.1 of the IGC Code is also to cover process pressure vessels and secondary barriers.

#### 7.2.2 Test requirements - bend tests (1/1/2021)

IGC CODE REFERENCE : Ch 6, 6.5.3.5.2

As an alternative to the bend test indicated in paragraph 6.5.3.5.2 of the IGC Code, a test over a mandrel having a diameter equal to 3 times the thickness with a bend angle up to 120° may be required.

## 8 Electrical installations

### 8.1 General

#### 8.1.1 (1/1/2021)

A FMEA or equivalent analysis is to be carried out according to IGC Code, 10.2.6 and submitted to the Society for approval.

## 8.2 Hazardous location classification and permitted electrical equipment

### 8.2.1 General (1/1/2021)

The hazardous location classification is to be the result of an interdisciplinary activity that takes into account the results of the risk assessment. In particular, it is to include e.g. properties of flammable materials, process and related electrical and safety equipment. The rationale of the hazardous area selection is to be properly documented and sent to the Society for information.

## 8.3 Process plant location classification and permitted electrical equipment

### 8.3.1 (1/1/2021)

Hazardous location classification is to be carried out in accordance with the following requirements and IEC 60079-10, or, alternatively, with an acceptable Code or Standard providing an equivalent safety.

### 8.3.2 (1/1/2021)

It is to be taken into consideration that the horizontal extent of the hazardous areas at ground level will increase with increasing relative density of the gas or vapour which may be released and the vertical extent above the source will increase with decreasing the gas or vapour relative density.

### 8.3.3 (1/1/2021)

Zone 0 hazardous location normally include areas or spaces:

- a) within process apparatus developing flammable gas or vapours;
- b) within enclosed pressure vessels or storage tanks;
- c) around vent pipes which discharges continually or for long periods;
- d) over/near surface of flammable liquids in general.

## 9 Safety system and fire protection

### 9.1 General requirements and definitions

#### 9.1.1 (1/1/2021)

The safest conditions for the systems on board are to be defined.

#### 9.1.2 (1/1/2021)

All equipment and systems are to be equipped with indicating or monitoring instruments and devices necessary for safe operation.

#### 9.1.3 (1/1/2021)

Emergency shutdown systems are to be provided against hazardous events.

Production systems are to be equipped with shutdown systems.

Systems that could jeopardize safety if they fail or operate outside pre-set conditions are to be provided with automatic shutdown.

#### 9.1.4 (1/1/2021)

An emergency shutdown system (ESD) includes:

- a) manual input devices (push buttons)

- b) interfaces towards other safety systems, e.g.:
- fire detection system
  - gas detection system
  - alarm and communication systems
  - process shutdown system
  - fire-fighting systems
  - ventilation systems
  - blowdown systems , venting systems and High integrity pressure protection systems, as applicable.

## 9.2 Basic design principles

### 9.2.1 (1/1/2021)

Inter-trips between process systems are to be initiated as a result of any initial event which could cause undesirable cascade effects in other parts of the plant before operator intervention can be realistically expected.

### 9.2.2 (1/1/2021)

Emergency shutdown is to initiate a process shut-down.

### 9.2.3 (1/1/2021)

The shutdown system is to be completely independent of control systems used for normal operation. See also Pt C, Ch 3, Sec 2, [1.1.4].

### 9.2.4 (1/1/2021)

The shutdown system is to be capable to monitor critical parameters and bring the system to a safe condition if specified conditions are exceeded. See also Pt C, Ch 3, Sec 2, [5].

## 10 Instrumentation (gauging, gas detection)

### 10.1 Indicator location

#### 10.1.1 Monitoring list (1/1/2021)

IGC CODE REFERENCE : Ch. 13

A "cargo control room" as dealt with in 3.4.1 of IGC Code is to be provided.

The information and alarms relevant to the containment, handling and process systems are to be transferred in the cargo control room.

### 10.2 Protected spaces

#### 10.2.1 (1/1/2021)

IGC CODE REFERENCE : Ch. 13, 13.6.2

In addition to the list in paragraph 13.6.2 of the IGC Code, the gas detection system is also to serve:

- spaces adjacent to pump rooms and compressor rooms
- areas where process equipment is located including gas compressors areas
- air locks and doorways to enclosed non hazardous areas;
- intakes for ventilation air, and
- ventilation outlets from hazardous areas mechanically ventilated.



Part E  
**Service Notations**

Chapter 10  
**TANKERS**

---

- SECTION 1      GENERAL**
- SECTION 2      HULL AND STABILITY**
- SECTION 3      MACHINERY AND CARGO SYSTEMS**



# SECTION 1 GENERAL

## 1 General

### 1.1 Application

**1.1.1** Ships complying with the requirements of this Chapter are eligible for the assignment of the service notation **tanker**, as defined in Pt A, Ch 1, Sec 2, [4.5.7] and Pt A, Ch 1, Sec 2, [4.3.7].

**1.1.2** Ships dealt with in this Chapter are to comply with the requirements stipulated in Parts A, B, C and D of the Rules, as applicable, and with the requirements of this Chapter, which are specific to tankers.

**1.1.3** The liquid cargoes which are allowed to be carried by such ships are specified in Ch 7, App 4.

### 1.2 Summary table

**1.2.1** Table 1 indicates, for ready reference, the Sections of this Chapter containing specific requirements applicable to tankers.

**Table 1**

Main subject	Reference
Ship arrangement	(1)
Hull and stability	Section 2
Machinery and cargo system	Section 3
Electrical installations	(1)
Automation	(1)
Fire protection, detection and extinction	(1)
(1) No specific requirements for tankers are given in this Chapter.	

## SECTION 2 HULL AND STABILITY

### 1 General arrangement design

#### 1.1 Compartment arrangement

##### 1.1.1 General (1/7/2008)

Tankers may be built with independent or integral tanks.

In the case of carriage of edible liquids it is assumed that cargo tanks are not used for any other purposes than transport of edible liquids, except under emergency conditions.

Specification of tank coating with certificate of acceptance for toxicity and tainting testing by recognized laboratory or health authority is to be submitted.

##### 1.1.2 Integral tanks

Cofferdams are to be fitted between tanks and compartments intended for liquids likely to alter edible liquids carried.

Tanks are to be separated from any compartment containing heat sources by cofferdams or duly heat-insulated bulkheads.

##### 1.1.3 Arrangement of tanks

In general, each tank is to be fitted with:

- a graduated metal gauge rod or any other equivalent sounding device
- an inspection door of adequate size fitted with a watertight metal cover secured by wing bolts or any other device offering equivalent safety
- an expansion system intended to avoid any excessive pressure and any risk of overflow due to a rise in temperature or occasional fermentation; the expansion capacity is to be about 0,5% of the tank cubic capacity
- a drain well that may be suppressed where precautions are taken to improve the running of liquids towards the suction pipes.

### 2 Stability

#### 2.1 Intact stability

##### 2.1.1 General

The stability of the ship for the loading conditions in Pt B, Ch 3, App 2, [1.2.3] is to be in compliance with the requirements in Pt B, Ch 3, Sec 2.

In general, a representative sample of loading conditions intended to be used for the ship is also to be submitted. The

additional loading conditions are also to be in compliance with the requirements of Pt B, Ch 3, Sec 2.

### 3 Structure design principles

#### 3.1 Materials

##### 3.1.1 Steels for hull structure

For ships having a poop, the steel type used for the strength deck plating in way of the poop front is to be extended forward to cover any pump room openings.

### 4 Design loads

#### 4.1 Hull girder loads

##### 4.1.1 Still water loads

In addition to the requirements in Pt B, Ch 5, Sec 2, [2.1.2], still water loads are to be calculated for the following loading conditions:

- homogeneous loading conditions (excluding tanks intended exclusively for segregated ballast tanks) at maximum draft
- partial loading conditions
- any specified non-homogeneous loading condition
- light and heavy ballast conditions
- mid-voyage conditions relating to tank cleaning or other operations where, at the Society's discretion, these differ significantly from the ballast conditions.

### 5 Hull scantlings

#### 5.1 Plating

##### 5.1.1 Minimum net thicknesses (1/7/2002)

The net thickness of the strength deck and bulkhead plating within or bounding the longitudinal extension of the cargo area is to be not less than the values given in Tab 1.



**Table 1 : Minimum net thickness of the strength deck and bulkhead plating**

Plating	Minimum net thickness (mm)	
Strength deck	$(5,5 + 0,02 L) k^{1/2}$	for $L < 200$
	$(8 + 0,0085 L) k^{1/2}$	for $L \geq 200$
Tank bulkhead	$L^{1/3} k^{1/6} + 4,5 s$	for $L < 275$
	$1,5 k^{1/2} + 8,2 + s$	for $L \geq 275$
Watertight bulkhead	$0,85 L^{1/3} k^{1/6} + 4,5 s$	for $L < 275$
	$1,5 k^{1/2} + 7,5 + s$	for $L \geq 275$
Wash bulkhead	$0,8 + 0,013 L k^{1/2} + 4,5 s$	for $L < 275$
	$3 k^{1/2} + 4,5 + s$	for $L \geq 275$
<b>Note 1:</b>		
k	: Material factor for steel, defined in Pt B, Ch 4, Sec 1, [2.3].	
s	: Length, in m, of the shorter side of the plate panel.	

## 5.2 Ordinary stiffeners

### 5.2.1 Minimum net thicknesses

The net thickness of the web of ordinary stiffeners is to be not less than the value obtained, in mm, from the following formulae:

$$t_{\text{MIN}} = 0,75 L^{1/3} k^{1/6} + 4,5 s \quad \text{for } L < 275$$

$$t_{\text{MIN}} = 1,5 k^{1/2} + 7,0 + s \quad \text{for } L \geq 275$$

where s is the spacing, in m, of ordinary stiffeners.

## 5.3 Primary supporting members

### 5.3.1 Minimum net thicknesses

The net thickness of plating which forms the webs of primary supporting members is to be not less than the value obtained, in mm, from the following formula:

$$t_{\text{MIN}} = 1,45 L^{1/3} k^{1/6}$$

## 5.4 Scantlings of independent tank structure

### 5.4.1 Structure in way of the connection between the tank and the hull structure

The tanks are to be locally strengthened in way of their connection to the hull structure and of their securing points, if any.

The structure of the ship is to be strengthened so as to avoid excessive deformations, due to the weight of the full tanks

and inertia forces caused by motions of the ship, specified in Part B, Chapter 5.

## 5.5 Strength check with respect to stresses due to the temperature gradient

### 5.5.1 (1/7/2018)

Direct calculations of stresses induced in the hull structures by the temperature gradient are to be performed for ships intended to carry cargoes at temperatures exceeding 90°C. In these calculations, the water temperature is to be assumed equal to 0°C.

The calculations are to be submitted to the Society for review.

**5.5.2** The stresses induced in the hull structures by the temperature gradient are to comply with the checking criteria in Pt B, Ch 7, Sec 3, [4.3].

## 6 Other structures

### 6.1 Machinery space

#### 6.1.1 Extension of the hull structures within the machinery space

Longitudinal bulkheads carried through cofferdams are to continue within the machinery space and be used preferably as longitudinal bulkheads for liquid cargo tanks. In any case, such extension is to be compatible with the shape of the structures of the double bottom, deck and platforms of the machinery space.

## 7 Protection of hull metallic structures

### 7.1 Coating of tank shells

**7.1.1** Coating of the inside of tanks is to be obtained by means of an appropriate composition, unless the size and type of the tank allows baked enamelling.

Coatings are to be applied according to the Manufacturer's specifications. Arrangements are to be made in order to remove solvents completely before using the tanks.

Coatings are to have appropriate shock-resisting qualities and be able to withstand any foreseeable working of the structure of the ship or tank without risking crack formation.

## SECTION 3

## MACHINERY AND CARGO SYSTEMS

### 1 General

#### 1.1 Documents to be submitted

1.1.1 The documents listed in Tab 1 are to be submitted for approval.

### 2 Piping systems

#### 2.1 General

##### 2.1.1 Materials

- a) Materials used for piping systems are to comply with the provisions of Pt C, Ch 1, Sec 10, [2.1].
- b) Attention is drawn to any national standards or regulations which might restrict the use of materials in contact with edible substances.

##### 2.1.2 Independence of piping systems

- a) The cargo piping system is to be entirely separated from other piping systems serving the ship.
- b) In the case of carriage of edible substances, arrangements are to be made to avoid any inadvertent contamination of the cargo. In particular, the filling and discharge connections serving the cargo tanks are to be located remote from those serving the machinery piping systems.

##### 2.1.3 Passage of pipes through tanks

Cargo tanks containing edible substances are not to be passed through by pipes conveying other liquids.

#### 2.2 Cargo piping and pumping

##### 2.2.1 Cargo pumps (1/7/2008)

At least two cargo pumps are to be provided for transferring the cargo.

In the case of carriage of edible liquids, submerged cargo pumps may be used provided that they are fitted with a double barrier between the driving oil and cargo; oil or cargo leakages into the double barrier are to be detectable.

Hydraulically operated valves are not to be located inside cargo tanks unless the hydraulic fluid used is harmless to

the edible liquid quality in case of a leakage of hydraulic fluid.

##### 2.2.2 Level gauging systems

Level gauging systems of tanks containing edible substances are to be so designed as to avoid any contamination of the cargo.

#### 2.3 Air pipes

##### 2.3.1

- a) Air pipes of cargo tanks are to be fitted with automatic closing appliances. Refer to Pt C, Ch 1, Sec 10, [9.1].
- b) Air pipes of tanks containing edible substances are to be led as far as practicable from:
  - air pipes of sewage or flammable oil tanks
  - machinery ventilation outlets.

#### 2.4 Refrigerating installations

##### 2.4.1

- a) Where the cargo needs to be kept refrigerated for conservation purposes, the refrigerating installation is to comply with the applicable provisions of Part F, Chapter 8.
- b) Provisions are to be made to avoid any contamination of the cargo by the refrigeration fluid.

#### 2.5 Cargo tank cleaning systems

2.5.1 Adequate means are to be provided for cleaning the cargo tanks.

#### 2.6 Additional requirements for ships carrying category Z substances

2.6.1 Tankers carrying category Z substances are to comply with the provisions of Ch 7, Sec 4, [8.2].

#### 2.7 Integrated cargo and ballast system

##### 2.7.1 (1/1/2004)

The requirements for integrated cargo and ballast systems are given in Ch 7, Sec 4, [3.5].

**Table 1 : Documents to be submitted**

Item No.	Description of the document (1)
1	Diagram of the cargo piping system
2	Diagram of the cargo tank venting system
3	Diagram of the cargo tank level gauging system
4	Diagram of the cargo tank cleaning system
5	Diagram of the bilge and ballast systems serving the cargo spaces
6	Diagram of the cargo heating and refrigerating systems
<p>(1) Diagrams are also to include, where applicable:</p> <ul style="list-style-type: none"> <li>• the (local and remote) control and monitoring systems and automation systems</li> <li>• the instructions for the operation and maintenance of the piping system concerned (for information).</li> </ul>	



Part E  
**Service Notations**

Chapter 11  
**PASSENGER SHIPS**

---

- SECTION 1      GENERAL**
- SECTION 2      SHIP ARRANGEMENT**
- SECTION 3      HULL AND STABILITY**
- SECTION 4      MACHINERY AND SYSTEMS**
- SECTION 5      ELECTRICAL INSTALLATIONS**



# SECTION 1 GENERAL

## 1 General

### 1.1 Application

**1.1.1** Ships complying with the requirements of this Chapter are eligible for the assignment of the service notation **passenger ship**, as defined in Pt A, Ch 1, Sec 2, [4.6.2].

**1.1.2** Ships dealt with in this Chapter are to comply with the requirements stipulated in Parts A, B, C and D of the Rules, as applicable, and with the requirements of this Chapter, which are specific to passenger ships.

### 1.2 Summary table

**1.2.1** Table 1 indicates, for easy reference, the Sections of this Chapter dealing with requirements applicable to passenger ships.

**Table 1**

Main subject	Reference
Ship arrangement	Sec 2
Hull and stability	Sec 3
Machinery and systems	Sec 4
Electrical installations	Sec 5
Automation	(1)
Fire protection, detection and extinction	(2)
(1) No specific requirements for passenger ships are given in this Chapter.	
(2) The specific requirements for passenger ships are given in Pt C, Ch 4.	

## SECTION 2 SHIP ARRANGEMENT

### 1 General

#### 1.1 Definitions

##### 1.1.1 Subdivision load line

*Subdivision load line is a waterline used in determining the subdivision of the ship.*

##### 1.1.2 Deepest subdivision load line

*Deepest subdivision load line is the waterline which corresponds to the greatest draught permitted by the subdivision requirements which are applicable.*

##### 1.1.3 Length $L_s$

*Length  $L_s$  is the length measured between perpendiculars taken at the extremities of the deepest subdivision load line. The length referred to in [2] is the length  $L_s$ .*

##### 1.1.4 Bulkhead deck

*Bulkhead deck is the uppermost deck up to which the transverse watertight bulkheads are carried.*

##### 1.1.5 Margin line

*Margin line is a line drawn at least 76 mm below the upper surface of the bulkhead deck at side.*

##### 1.1.6 Passenger spaces

*Passenger spaces are those spaces which are provided for the accommodation and use of passengers, excluding baggage, store, provision and mail rooms.*

*In all cases volumes and areas are to be calculated to moulded lines.*

### 2 General arrangement design

#### 2.1 Arrangement of the collision bulkhead

##### 2.1.1 (1/7/2018)

For the arrangement of the collision bulkhead, see Pt B, Ch 2, Sec 1, [2.1].

#### 2.2 After peak bulkhead, machinery space bulkheads and sterntubes

**2.2.1** *An after peak bulkhead, and bulkheads dividing the machinery space from the cargo and passenger spaces forward and aft, are to also be fitted and made watertight up to the bulkhead deck. The after peak bulkhead may, however, be stepped below the bulkhead deck, provided the degree of safety of the ship as regards subdivision is not thereby diminished.*

**2.2.2** *In all cases sterntubes are to be enclosed in watertight spaces of moderate volume. The stern gland is to be situated in a watertight shaft tunnel or other watertight*

*space separate from the sterntube compartment and of such volume that, if flooded by leakage through the stern gland, the margin line is not submerged.*

#### 2.3 Openings in watertight bulkheads below the bulkhead deck

##### 2.3.1 Openings in machinery spaces

*Not more than one door apart from the doors to bunkers and shaft tunnels may be fitted in each main transverse bulkhead within spaces containing the main and auxiliary propulsion machinery including boilers serving the needs of propulsion and all permanent bunkers. Where two or more shafts are fitted the tunnels are to be connected by an intercommunicating passage. Only one door is to be provided between the machinery space and the tunnel spaces where two shafts are fitted and only two doors where there are more than two shafts. All these doors are to be of the sliding type and are to be so located as to have their sills as high as practicable. The hand gear for operating these doors from above the bulkhead deck is to be situated outside the spaces containing the machinery.*

*Portable plates on bulkheads are not permitted except in machinery spaces. Such plates are always to be in place before the ship leaves port, and are not to be removed during navigation except in the case of urgent necessity at the discretion of the Master. The times of removal and replacement of any such portable plates are to be recorded in the log-book, and the necessary precautions are to be taken in replacing them to ensure that the joints are watertight. The Society may permit not more than one power-operated sliding watertight door in each main transverse bulkhead larger than 1,20 m to be substituted for these portable plates, provided these doors are closed before the ship leaves port and remain closed during navigation except in the case of urgent necessity at the discretion of the Master. These doors need not meet the requirements of complete closure by hand-operated gear in 90 seconds (see [2.5.3] e). The time of opening and closing these doors, whether the ship is at sea or in port, is to be recorded in the log-book.*

##### 2.3.2 Openings in cargo spaces

*Watertight doors complying with the requirements of [2.5.1] may be fitted in watertight bulkheads dividing cargo between deck spaces. Such doors may be hinged, rolling or sliding doors but are not to be remotely controlled. They are to be fitted at the highest level and as far from the shell plating as practicable, but in no case are the outboard vertical edges to be situated at a distance from the shell plating which is less than one fifth of the breadth of the ship, such distance being measured at right angles to the centreline at the level of the deepest subdivision load line. The doors accessible during the voyage are to be fitted with a device which prevents unauthorised opening. Manholes, or access in transverse watertight bulkheads dividing a cargo space*



from an adjoining cargo space or from a permanent reserve bunker, may also be accepted by the Society.

### 2.3.3 Openings in passenger ships carrying goods vehicles and accompanying personnel

This requirement applies to passenger ships designed or adapted for the carriage of goods vehicles and accompanying personnel where the total number of persons on board, other than passengers as defined in Pt A, Ch 1, Sec 2, [4.6.2], exceeds 12.

If in such a ship the total number of passengers which include personnel accompanying vehicles does not exceed:

$$N = 12 + \frac{A}{25}$$

where:

*N* : the maximum number of passengers for which the ship is certified

*A* : the total deck area, in m<sup>2</sup>, of spaces available for the stowage of goods vehicles,

and where the clear height at the stowage position and at the entrance to such spaces is not less than 4 m, the provisions of [2.3.2] in respect of watertight doors apply except that the doors may be fitted at any level in watertight bulkheads dividing cargo spaces.

Additionally, indicators are required on the navigating bridge to show automatically when each door is closed and all door fastenings are secured.

### 2.3.4 Trunks and tunnels

Where trunkways or tunnels for access from crew accommodation to the stokehold, for piping, or for any other purpose are carried through main transverse watertight bulkheads, they are to be watertight and in accordance with the requirements of Pt B, Ch 4, Sec 7, [1.3]. The access

to at least one end of each such tunnel or trunkway, if used as a passage at sea, is to be through a trunk extending watertight to a height sufficient to permit access above the margin line. The access to the other end of the trunkway or tunnel may be through a watertight door of the type required by its location in the ship. Such trunkways or tunnels are not to extend through the first subdivision bulkhead abaft the collision bulkhead.

Where trunkways in connection with refrigerated cargo and ventilation or forced draught trunks are carried through more than one watertight bulkhead, the means of closure at such openings are to be operated by power and be capable of being closed from a central position situated above the bulkhead deck.

### 2.3.5 Additional requirements

In addition to [2.3.1], [2.3.2], [2.3.3], and [2.3.4], the requirements reported in [2.5.3] are to be complied with.

## 2.4 Openings in bulkheads above the bulkhead deck

### 2.4.1 General

Measures such as the fitting of partial bulkheads or diaphragms are to be taken to limit the entry and spread of water above the bulkhead deck. When partial watertight bulkheads and diaphragms are fitted on the bulkhead deck, above or in the immediate vicinity of main subdivision bulkheads, their connections with the shell and bulkhead deck are to be watertight so as to restrict the flow of water along the deck when the ship is in a heeled damaged condition. Where the partial watertight bulkhead does not line up with the bulkhead below, the bulkhead deck between is to be made effectively watertight.

Table 1 : Doors

			Sliding type			Hinged type			Rolling type (cargo between deck spaces)
			remote operation indication on the bridge	indicator on the bridge	local operation only	remote operation indication on the bridge	indicator on the bridge	local operation only	
water-tight	below the bulkhead deck	open at sea	X						
		normally closed (4)	X						
		remain closed (4)				X (1)		X (1) (3)	
weathertight / semi-watertight (2)	above bulkhead deck	open at sea	X			X			
		normally closed (4)		X			X		
		remain closed (4)						X	

(1) The door is to be closed before the voyage commences.  
(2) Semi-watertight doors are required when they are located below the waterline at the equilibrium of the intermediate stages of flooding.  
(3) If the door is accessible during the voyage, a device which prevents unauthorised opening is to be fitted.  
(4) Notice to be affixed on both sides of the door: "to be kept closed at sea".

The bulkhead deck or a deck above it is to be weathertight. The coamings of all openings in the exposed weather deck are to be of ample height and strength and are to be provided with efficient means for expeditiously closing them weathertight. Freeing ports, open rails and scuppers are to be fitted as necessary for rapidly cleaning the weather deck of water under all weather conditions.

Sidescuttles, gangway, cargo and coaling ports and other means for closing openings in the shell plating above the margin line are to be of efficient design and construction and of sufficient strength (see Pt B, Ch 9, Sec 9) having regard to the spaces in which they are fitted and their positions relative to the deepest subdivision load line.

Efficient inside deadlights, so arranged that they can be easily and effectively closed and secured watertight, are to be provided for all sidescuttles to spaces below the first deck above the bulkhead deck.

#### 2.4.2 Open end of air pipes

The open end of air pipes terminating within a superstructure is to be at least 1 m above the waterline when the ship heels to an angle of 15 degrees, or the maximum angle of heel during intermediate stages of flooding, as determined by direct calculation, whichever is the greater. Where no information regarding the above angle of heel is available, the open end of air pipes terminating within a superstructure is to be at least 1 m above the waterline when the ship heels to an angle of 15° or 0,5 m above the waterline when the ship heels to an angle of 15° from the bulkhead deck, whichever is the greater.

Alternatively, air pipes from tanks other than oil tanks may discharge through the side of the superstructure. The provisions of this paragraph are without prejudice to the provisions of the International Convention on Load Lines in force.

#### 2.4.3 Additional requirements

In addition to [2.4.1], [2.4.2], the requirements in [2.5.4] are to be complied with.

### 2.5 Doors

#### 2.5.1 Requirements for doors

The requirements relevant to the degree of tightness, as well as the operating systems, for doors complying with the prescriptions in [2.5.2] and [2.5.3] are specified in Tab 1.

#### 2.5.2 Construction of watertight doors

The design, materials and construction of all watertight doors are to be to the satisfaction of the Society.

The frames of vertical watertight doors are to have no groove at the bottom in which dirt might lodge and prevent the door closing properly.

#### 2.5.3 Doors in watertight bulkheads below the bulkhead deck

- a) Watertight doors are to be capable of being closed simultaneously from the central operating console at the navigation bridge in not more than 60 s with the ship in the upright position.
- b) The means of operation whether by power or by hand of any power-operated sliding watertight door are to be

capable of closing the door with the ship listed to 15° either way. Consideration is to also be given to the forces which may act on either side of the door as may be experienced when water is flowing through the opening applying a static head equivalent to a water height of at least 1 m above the sill on the centreline of the door.

- c) Watertight door controls, including hydraulic piping and electrical cables, are to be kept as close as practicable to the bulkhead in which the doors are fitted, in order to minimise the likelihood of them being involved in any damage which the ship may sustain. The positioning of watertight doors and their controls are to be such that if the ship sustains damage within one fifth of the breadth of the ship, such distance being measured at right angles to the centreline at the level of the deepest subdivision load line, the operation of the watertight doors clear of the damaged portion of the ship is not impaired.
- d) All power-operated sliding watertight doors are to be provided with means of indication which show at all remote operating positions whether the doors are open or closed. Remote operating positions are only to be located at the navigating bridge and at the location where hand operation above the bulkhead deck is required by e).
  - e) Each power-operated sliding watertight door:
    - is to move vertically or horizontally;
    - is to be normally limited to a maximum clear opening width of 1,20 m. The Society may permit larger doors only to the extent considered necessary for the effective operation of the ship provided that other safety measures, including the following, are taken into consideration:
      - special consideration is to be given to the strength of the door and its closing appliances in order to prevent leakages;
      - the door is to be located outside the damage zone B/5;
      - the door is to be kept closed when the ship is at sea, except for limited periods when absolutely necessary as determined by the Society.
    - is to be fitted with the necessary equipment to open and close the door using electrical power, hydraulic power, or any other form of power that is acceptable to the Society;
    - is to be provided with an individual hand-operated mechanism. It is to be possible to open and close the door by hand at the door itself from either side and, in addition, close the door from an accessible position above the bulkhead deck with an all round crank motion or some other movement providing the same degree of safety acceptable to the Society. Direction of rotation or other movement is to be clearly indicated at all operating positions. The time necessary for the complete closure of the door, when operating by hand gear, may not exceed 90 s with the ship in the upright position;
    - is to be provided with controls for opening and closing the door by power from both sides of the door

and also for closing the door by power from the central operating console at the navigation bridge;

- is to be provided with an audible alarm, distinct from any other alarm in the area, which is to sound whenever the door is closed remotely by power and which is to sound for at least 5 s but no more than 10 s before the door begins to move and is to continue sounding until the door is completely closed. In the case of remote hand operation it is sufficient for the audible alarm to sound only when the door is moving. Additionally, in passenger areas and areas of high ambient noise, the Society may require the audible alarm to be supplemented by an intermittent visual signal at the door;
- is to have an approximately uniform rate of closure under power. The closure time, from the time the door begins to move to the time it reaches the completely closed position, is to in no case be less than 20 s or more than 40 s with the ship in the upright position.

- f) The electrical power required for power-operated sliding watertight doors is to be supplied from the emergency switchboard either directly or by a dedicated distribution board situated above the bulkhead deck. The associated control, indication and alarm circuits are to be supplied from the emergency switchboard either directly or by a dedicated distribution board situated above the bulkhead deck and be capable of being automatically supplied by a transitional source of emergency electrical power in the event of failure of either the main or emergency source of electrical power.

The transitional source of emergency electrical power is to consist of an accumulator battery suitably located for use in an emergency which is to operate without recharging while maintaining the voltage of the battery throughout the discharge period within 12% above or below its nominal voltage and be of sufficient capacity and so arranged as to supply power automatically, in the event of failure of either the main or emergency source of electrical power, to control, indication and alarm circuits at least for half an hour.

- g) Power-operated sliding watertight doors are to have either:

- a centralised hydraulic system with two independent power sources each consisting of a motor and pump capable of simultaneously closing all doors. In addition, there are to be for the whole installation hydraulic accumulators of sufficient capacity to operate all the doors at least three times, i.e. closed-open-closed, against an adverse list of 15°. This operating cycle is to be capable of being carried out when the accumulator is at the pump cut-in pressure. The fluid used is to be chosen considering the temperatures liable to be encountered by the installation during its service. The power operating system is to be designed to minimise the possibility of having a single failure in the hydraulic piping adversely affect the operation of more than one door. The hydraulic system is to be provided with a low-level alarm for hydraulic fluid reservoirs serving the

power-operated system and a low gas pressure group alarm or other effective means of monitoring loss of stored energy in hydraulic accumulators. These alarms are to be audible and visual and are to be situated on the central operating console at the navigating bridge; or

- an independent hydraulic system for each door with each power source consisting of a motor or pump capable of opening and closing the door. In addition, there is to be a hydraulic accumulator of sufficient capacity to operate the door at least three times, i.e. closed-open-closed, against an adverse list of 15°. This operating cycle is to be capable of being carried out when the accumulator is at the pump cut-in pressure. The fluid used is to be chosen considering the temperatures liable to be encountered by the installation during its service. A low gas pressure group alarm or other effective means of monitoring loss of stored energy in hydraulic accumulators is to be provided at the central operating console on the navigation bridge. Loss of stored energy indication at each local operating position is to also be provided; or
- an independent electrical system and motor for each door with each power source consisting of a motor capable of opening and closing the door. The power source is to be capable of being automatically supplied by the transitional source of emergency electrical power in the event of failure of either the main or emergency source of electrical power and with sufficient capacity to operate the door at least three times, i.e. closed-open-closed, against an adverse list of 15°.

The transitional source of emergency electrical power is to consist of an accumulator battery suitably located for use in an emergency which is to operate without recharging while maintaining the voltage of the battery throughout the discharge period within 12% above or below its nominal voltage and be of sufficient capacity and so arranged as to supply power automatically, in the event of failure of either the main or emergency source of electrical power, to watertight doors, but not necessarily all of them simultaneously, unless an independent source of stored energy is provided.

For the systems specified above, provision is to be made as follows:

Power systems for power-operated watertight sliding doors are to be separate from any other power system. A single failure in the electrical or hydraulic power-operated systems excluding the hydraulic actuator may not prevent the hand operation of any door.

- h) Control handles are to be provided at each side of the bulkhead at a minimum height of 1,6 m above the floor and are to be so arranged as to enable persons passing through the doorway to hold both handles in the open position without being able to set the power closing mechanism in operation accidentally. The direction of movement of the handles in opening and closing the

door is to be in the direction of door movement and is to be clearly indicated.

- i) As far as practicable, electrical equipment and components for watertight doors are to be situated above the bulkhead deck and outside hazardous areas and spaces.
- j) The enclosures of electrical components necessarily situated below the bulkhead deck are to provide suitable protection against the ingress of water.
- k) Electric power, control, indication and alarm circuits are to be protected against faults in such a way that a failure in one door circuit may not cause a failure in any other door circuit. Short-circuits or other faults in the alarm or indicator circuits of a door may not result in a loss of power operation of that door. Arrangements are to be such that leakage of water into the electrical equipment located below the bulkhead deck may not cause the door to open.
- l) A single electrical failure in the power operating or control system of a power-operated sliding watertight door may not result in a closed door opening. Availability of the power supply is to be continuously monitored at a point in the electric circuit as near as practicable to each of the motors required in g). Loss of any such power supply is to activate an audible and visual alarm at the central operating console at the navigation bridge.
- m) The central operating console at the navigation bridge is to have a "master mode" switch with two modes of control:
  - a "local control" mode which is to allow any door to be locally opened and locally closed after use without automatic closure, and
  - a "doors closed" mode which is to automatically close any door that is open. The "doors closed" mode is to permit doors to be opened locally and is to automatically reclose the doors upon release of the local control mechanism.

The "master mode" switch is to normally be in the "local control" mode. The "doors closed" mode is to only be used in an emergency or for testing purposes. Special consideration is to be given to the reliability of the "master mode" switch.
- n) The central operating console at the navigation bridge is to be provided with a diagram showing the location of each door, with visual indicators to show whether each door is open or closed. A red light is to indicate a door is fully open and a green light is to indicate a door is fully closed. When the door is closed remotely the red light is to indicate the intermediate position by flashing. The indicating circuit is to be independent of the control circuit for each door.
- o) It is not to be possible to remotely open any door from the central operating console.
- p) All watertight doors are to be kept closed during navigation. Certain watertight doors may be permitted to remain open during navigation only if considered absolutely necessary; that is, being open is determined essential to the safe and effective operation of the ship's

machinery or to permit passengers normally unrestricted access throughout the passenger area. Such determination is to be made by the Society only after careful consideration of the impact on ship operations and survivability. A watertight door permitted to remain thus open is to be clearly indicated in the ship's stability information and the damage control documentation and is always to be ready for immediate closure.

#### 2.5.4 Doors in watertight bulkheads above the bulkhead deck

##### a) General

Doors are to be capable of being opened and closed by hand locally from both sides of the doors with the ship listed to 15° to either side. If the ship is allowed to heel up to 20°, during intermediate stages of flooding, then the doors are to be capable of operation by hand with the ship listed to 20° to either side.

Position indicators are to be provided on the bridge as well as locally on both sides of the doors to show that the doors are open or closed and that the dogs are fully and properly engaged.

Where the doors also serve as fire doors they are to be provided with position indicators at the fire control station and audible alarms as required for fire doors, as well as for weathertight doors. Where two doors are fitted they must be capable of independent operation remotely and from both sides of each door.

##### b) Doors normally closed at sea

In addition to a), doors not required for frequent access while at sea are to be kept normally closed and may be of either hinged or sliding type.

Doors kept normally closed are to have local operation from both sides of the doors and are to be labelled on both sides: "to be kept closed at sea".

##### c) Doors normally open at sea

Where fitted in public spaces for the passage of passengers and crew, the doors may be kept normally open at sea and may be either hinged or sliding type.

In addition to a), doors kept normally open at sea are to have local power operation from both sides of the door and remote closing from the bridge. Operation of these doors is to use a "master mode" switch on the bridge, local control can override the remote closing feature after which the door is automatically remotely reclosed upon release of the local control mechanism.

Doors kept normally open at sea are to have audible alarms, distinct from any other alarm in the area, which sound whenever the doors are closed remotely. The alarms are to sound for at least 5 s but not more than 10 s before the doors begins to move and continue sounding until the doors are completely closed. In passenger areas and areas of high ambient noise, the audible alarms are to be supplemented by visual signals at both sides of the doors.

## 2.6 Compartment arrangement

### 2.6.1 Ballast compartments

*Water ballast may not in general be carried in tanks intended for fuel oil. In ships in which it is not practicable to avoid putting water in fuel oil tanks, oily-water separating equipment to the satisfaction of the Society is to be fitted, or other alternative means, such as discharge to shore facilities, acceptable to the Society is to be provided for disposing of the oily-water ballast (see Pt C, Ch 1, Sec 10, [7]).*

### 2.6.2 Machinery compartments (1/1/2011)

When longitudinal bulkheads are fitted in the machinery space, adequate self-operating arrangements are to be provided in order to avoid excessive heel after damage.

Where such arrangements are cross-flooding systems, their area is to be calculated in accordance with the requirements of IMO Res. MSC.245(83).

## SECTION 3

## HULL AND STABILITY

### 1 Stability

#### 1.1 Intact stability

##### 1.1.1 General (1/1/2009)

Every passenger ship regardless of size is to be inclined upon its completion and the elements of its stability determined. The Master is to be supplied with such information satisfactory to the Society as is necessary to enable him by rapid and simple processes to obtain accurate guidance as to the stability of the ship under varying conditions of service. A copy of the stability information is to be furnished to the Society.

Where any alterations are made to a ship so as to materially affect the stability information supplied to the Master, amended stability information is to be provided. If necessary the ship is to be re-inclined.

##### 1.1.2 Standard requirements

In addition to Pt B, Ch 3, Sec 2, [2] the requirements in [1.1.3] to [1.1.5] are to be complied with for the loading conditions defined in Pt B, Ch 3, App 2, [1.2.1] and Pt B, Ch 3, App 2, [1.2.9].

##### 1.1.3 Crowding of passengers (1/7/2024)

The angle of heel due to crowding of passengers (see [1.1.6]) to one side is not to exceed 10° and the freeboard deck is not to be immersed.

For ships lesser than 20 m in length, the angle of heel is not to be greater than the angle corresponding to a freeboard of 0,1 m before the deck's immersion, or 12° if less.

In elaborating the stability booklet, the following is to be assumed:

- A minimum weight of 75 kg for each passenger except that this value may be increased subject to the approval of the Society. In addition, the mass and distribution of the luggage is to be approved by the Society.
- The height of the centre of gravity for passengers shall be assumed equal to:
  - 1 m above deck level for passengers standing upright. Account may be taken, if necessary, of camber and sheer of deck; and
  - 0,3 m above the seat in respect of seated passengers.
- *Passengers and luggage shall be considered to be in the spaces normally at their disposal, when assessing compliance with the criteria given in Pt B, Ch 3, Sec 2, [2.1.2] to [2.1.5].*
- Passengers without luggage shall be considered as distributed to produce the most unfavourable combination of passenger heeling moment and/or initial metacentric height, which may be obtained in practice, when assessing compliance with the criteria given in

[1.1.6], respectively. In this connection, a value higher than four persons per square metre is not necessary.

##### 1.1.4 Maximum turning angle (1/7/2010)

The angle of heel on account of turning may not exceed 10° when calculated using the following formula:

$$M_R = 0,200 \frac{V_0^2}{L_{WL}} \Delta \left( KG - \frac{d}{2} \right)$$

where:

- $M_R$  : Heeling moment, in kNm
- $V_0$  : Service speed, in m/s
- $L_{WL}$  : Length of ship at waterline, in m
- $\Delta$  : Displacement, in t
- $d$  : Mean draught, in m
- $KG$  : Height of centre of gravity above keel, in m.

1.1.5 Where anti-rolling devices are installed in a ship, the Society is to be satisfied that the above criteria can be maintained when the devices are in operation.

##### 1.1.6 Ships engaged in still waters (1/7/2024)

###### a) Loading conditions

In addition to the loading conditions considered in Pt B, Ch 3, App 2, [1.2.1] and Pt B, Ch 3, App 2, [1.2.9], the loading condition at arrival, without cargo, with necessary water ballast, with all passengers, on all decks assigned to them, crowded on the same side of the ship, is also to be considered.

If in any real loading condition the stability of the ship is less favourable than in the requested conditions, the stability requirements are also to be checked in such real condition.

In elaborating the stability booklet, the following is to be assumed:

- weight of each person equal to 75 kg;
- centre of gravity of each person, both standing and sitting, equal to 0,90 m above the upper surface of the relevant deck;
- maximum allowable number of persons equal to the number of sitting places plus two passengers/m<sup>2</sup> in the areas available for passengers, clear from the persons seated.

A higher number of standing persons may be assumed provided that the competent authority agrees.

In calculating the area in which the passengers are crowded among the benches, the distance between two of them may be reduced by 0,3 m x l (length of the bench) to exclude the area obstructed by sitting passengers.

###### b) Stability requirements in all required loading conditions

The following stability requirements are to be complied with:

- 1) (r-a) to be not less than 0,30 m.

To this end passengers are to be considered accommodated taking all the sitting places and areas assigned to them with 4 passengers/m<sup>2</sup>, starting from the highest deck and proceeding to lower decks until the maximum allowable number of passengers is exceeded;

- 2) Distance between the upper surface of the main deck, at side, from the waterline in the final equilibrium status of heeled ship (residual minimum freeboard) to be not less than 0,20 m. For this purpose, passengers are to be considered accommodated on one side of the ship only, from the ship's centreline, taking all the sitting places and areas assigned to them with 4 passengers/m<sup>2</sup>, starting from the highest deck and proceeding to lower decks until the maximum allowable number of passengers is exceeded.

If the number of all the passengers on one side of the ship does not reach the maximum allowable number, the surplus of passengers is to be ignored in calculating the transversal heeling of the ship.

- 3) The maximum allowable number of passengers is to be the lower of 1 and 2 above. Such number may be further reduced taking into account the following:

- if the value calculated according to 1 leads to a value of (r-a) less than 0,30 m and this cannot be avoided by the use of ballast of the ship, or by other suitable operations, such number is to be decreased in the calculation by unloading a suitable number of passengers, starting from the lower deck, until (r-a) not less than 0,30 m is reached. Therefore, the resulting reduced number of passengers is to replace the one resulting from 1
- if the residual freeboard, calculated through the passenger distribution according to 2, is less than 0,20 m and it cannot be increased by ballasting the ship, or by other suitable operations, the number of passengers calculated according to 2 is to be decreased in the calculation by unloading a suitable number of passengers, starting from those standing closest to the midship plane on the lower deck. Obviously, in such operation an upper deck is not affected by unloading of passengers as far as first all those standing, and then those sitting, in the lower deck are unloaded.

The resulting reduced number of passengers is to replace the one resulting from 2.

- 4) Chains, railings or similar devices, fitted to segregate deck areas to prevent the presence of passengers during navigation, may be accepted by the Society on condition that the safe access to life saving

appliances and essential service of the ship (e.g. toilets, bar, etc.) is not impeded.

Such devices are not to obstruct escape routes, muster stations and embarkation points; are not to interfere with the safe abandonment of the ship; and are to be in place at all times during navigation. During boarding, these devices can be temporarily removed to ensure homogeneous distribution of boarding passengers, and are to be reinstalled before the voyage starts.

- 5) To facilitate the calculations, it is permissible not to take into account both the shear and the camber of the ship, but to evaluate the vertical positions of all the centres of gravity referring to the section at  $\frac{1}{2} L$ .
- 6) Any opening sidescuttles located below the upper deck which, because of the transversal heeling of the ship, may have their lowest point less than 0,20 m above the final waterline, are to be fitted with efficient devices such that they can be effectively closed and secured, under the Master's responsibility, while the passengers are on board. Such condition is to be noted in the ship's logbook. It is allowable in the calculations that such sidescuttles are partially or fully submerged at the end of the heeling.
- 7) In the case of decked ships of length less than 20 m, item b) applies and the required residual freeboard on the side of passenger crowding, to be not less than 0,20 m, is to correspond to a heeling angle not more than 15°. In the case of ships without decks, the residual freeboard after heeling due to the crowding of passengers on one side of the ship is to be not less than 0,30 m with an angle of heel not greater than 15°.

## 2 Structure design principles

### 2.1 Hull structure

#### 2.1.1 Framing

In general, the strength deck and the bottom of passenger ships of more than 100 m in length are to be longitudinally framed.

Where a transverse framing system is adopted for such ships, it is to be considered by the Society on a case-by-case basis.

## 3 Hull girder strength

### 3.1 Basic criteria

#### 3.1.1 Strength deck

In addition to the requirements in Pt B, Ch 6, Sec 1, [2.2], the contribution of the hull structures up to the strength deck to the longitudinal strength is to be assessed through a finite element analysis of the whole ship in the following cases:

- when the size of openings in the side shell and/or longitudinal bulkheads located below the deck assumed by the Designer as the strength deck decrease

significantly the capability of the plating to transmit shear forces to the strength deck

- when the ends of superstructures which are required to contribute to longitudinal strength may be considered not effectively connected to the hull structures in way.

## 4 Hull scantlings

### 4.1 Plating

#### 4.1.1 Minimum net thicknesses (1/7/2015)

The net thickness of the inner bottom, side, weather strength deck and external balcony plating is to be not less than the values given in Tab 1.

## 5 Other structures

### 5.1 Side doors and stern doors

**5.1.1** Side doors may be either below or above the freeboard deck.

Stern doors are to be situated above the freeboard deck.

**5.1.2** The requirements applicable to side doors and stern doors are defined in Pt B, Ch 9, Sec 6.

**Table 1 : Minimum net thickness of the inner bottom, side, weather strength deck and external balcony plating (1/7/2015)**

Plating	Minimum net thickness, in mm
Inner bottom outside engine room	$2,0 + 0,02 L k^{1/2} + 4,5 s$
Side	
• below freeboard deck	$2,1 + 0,028 L k^{1/2} + 4,5 s$
• between freeboard deck and strength deck	$2,1 + 0,013 L k^{1/2} + 4,5 s$
Weather strength deck and trunk deck	$2,2 k^{1/2} + 2,1 + s$
External balconies	$2,2 k^{1/2} + 1,6 + s$
<b>Note 1:</b>	
k	: Material factor for steel, defined in Pt B, Ch 4, Sec 1, [2.3].
s	: Length, in m, of the shorter side of the plate panel.



Table 2 : Equipment

Equipment number EN A < EN ≤ B		Stockless anchors		Stud link chain cables for anchors			
		N	Mass per anchor, in kg	Total length, in m	Diameter, in mm		
A	B				Q1	Q2	Q3
19	22	1	21	65	7		
22	25	1	27	70	7		
25	30	1	32	70	8		
30	35	1	37	75	8		
35	40	1	43	75	9		
40	45	1	53	80	10		
45	50	1	64	82,5	11		
50	60	1	80	82,5	11	10	
60	70	1	90	82,5	12,5	11	
70	80	1	100	110	12,5	11	10
80	90	1	120	110	14	12,5	11
90	100	1	140	110	14	12,5	11
100	110	1	160	110	16	14	12,5
110	120	1	180	110	16	14	12,5
120	130	1	200	110	16	14	12,5
130	140	1	240	110	17,5	16	14
140	150	1	260	137,5	17,5	16	14
150	175	1	300	137,5	19	17,5	16
175	205	1	360	137,5	20,5	17,5	16
205	240	1	420	137,5	22	19	17,5
240	280	1	480	137,5	24	20,5	19
280	320	1	575	165	26	22	20,5
320	360	1	660	165	28	24	22
360	400	1	700	165	30	26	22
400	450	1	780	165	30	26	24
450	500	1	900	192,5	32	28	26
500	550	1	1020	192,5	34	30	26
550	600	1	1140	192,5	36	32	28
600	660	2	1200	385	38	32	30
660	720	2	1295	385	40	34	30
720	780	2	1440	440	42	36	32
780	840	2	1500	440	42	36	32
840	910	2	1595	440	44	38	34
910	980	2	1740	440	46	40	36
980	1060	2	1920	440	48	42	36

## 6 Hull outfitting

### 6.1 Equipment

#### 6.1.1 Number of mooring lines

The specific requirements in Pt B, Ch 10, Sec 4, [3.5] for ships with the service notation **passenger ship** are to be complied with.

#### 6.1.2 Ships having $L \leq 30$ m and navigation notation other than unrestricted navigation

For ships having  $L \leq 30$  m and navigation notation other than **unrestricted navigation**:

- the equipment in stockless anchor and chain cables (or ropes according to Pt B, Ch 10, Sec 4, [3.3.5]) may be obtained from Tab 2
- the equipment in mooring lines of wire or natural fibre may be obtained from Tab 3.

**Table 3 : Mooring lines (1/1/2022)**

Equipment number EN $A < EN \leq B$		Mooring lines		
A	B	N	Length of each line, in m	Ship Design Minimum Breaking Load, in kN
19	50	2	40	32
50	70	3	40	34
70	90	3	50	37
90	110	3	55	39
110	130	3	55	44
130	150	3	60	49
150	175	3	60	54

## 7 Windows and sidescuttles

### 7.1 Application

#### 7.1.1 (1/7/2011)

The requirements in [7.2] apply to windows and sidescuttles, located in positions which are exposed to the action of sea and/or bad weather.

### 7.2 Thickness of glasses

#### 7.2.1 General (1/7/2011)

The minimum thickness  $t$ , in mm, of glasses is to be obtained from the formula in [7.2.2] and [7.2.3], where:

- $b$  : length of the shorter window side, in mm  
 $p$  : design pressure, in kN/m<sup>2</sup>, defined in [7.2.4]  
 $d$  : diameter of the window, in mm

$$\beta = 0,54A_r - 0,078A_r^2 - 0,17 \quad \text{for } (A_r < 3)$$

$$\beta = 0,75 \quad \text{for } A_r \geq 3$$

$$A_r = \frac{a}{b}$$

- $a$  : length of the longer window side, in mm

#### 7.2.2 Rectangular windows (1/7/2011)

$$t = \frac{b}{200} \sqrt{\beta p}$$

#### 7.2.3 Circular windows (1/7/2011)

$$t = \frac{d}{400} \sqrt{p}$$

#### 7.2.4 Design pressure (1/7/2020)

The design pressure  $p$ , in kN/m<sup>2</sup>, is to be obtained from Tab 4, where:

where:

- $f_w$  : 12,5 in way of sides and ends of superstructures  
 $f_w$  : 7,5 in way of house fronts  
 $Z_1$  : vertical distance, in m, from the base line to the point where the calculated pressure  $p_0$  is 15 kN/m<sup>2</sup>  
 $Z_2$  : vertical distance, in m, from the base line to the deck immediately above  $Z_1$   
 $Z_w$  : vertical distance, in m, from the base line to the point under consideration  
 $H_{td}$  : sum of the two 'tweendeck heights, in m, above  $Z_2$

$$p_0 = 10ac[bf - (z - T)]$$

- $a$  : Coefficient defined in Tab 5 to be taken not greater than the maximum value,  $a_{max}$ , specified in Tab 5  
 $c$  : Coefficient taken equal to:

$$c = 0,3 + 0,7 \frac{b_1}{B_1}$$

**Table 4 : Design pressure (1/7/2011)**

Window or sidescuttle location	Design pressure, in kN/m <sup>2</sup>
Between the summer waterline and a point located at a distance $Z_1$ , in m, above the base line	$p = p_0$
Between the points located at a distance $Z_1$ and $Z_2$ m above the waterline	$p = 15$
Above $Z_2$ for the next two 'tweendecks	$p = 15 - f_w \left( \frac{Z_w - Z_2}{H_{td}} \right)$
For subsequent decks to the top of the navigation bridge	$p = 2,5$ sides and aft ends $p = 7,5$ house fronts
From the top of the navigation bridge to the uppermost deck, for house front s	$p = 7,5$ at top of navigation bridge $p = 2,5$ at uppermost continuous deck, with linear variation between pressure at the top of the navigation bridge and pressure at the uppermost continuous deck.
From the top of the navigation bridge to the uppermost deck, at side and aft ends	$p = 2,5$

**Table 5 : Coefficient a (1/7/2020)**

Type of bulkhead	Location	a	a <sub>max</sub>
Unprotected front	Lower tier	$2 + \frac{L}{120}$	4,5
	Second tier	$1 + \frac{L}{120}$	3,5
	Third tier	$0,5 + \frac{L}{150}$	2,5
Protected front		$0,5 + \frac{L}{150}$	2,5
Side		$0,5 + \frac{L}{150}$	2,5

Type of bulkhead	Location	a	a <sub>max</sub>
Aft end of amid-ships	All tiers, when: $x/L \leq 0,5$	$0,7 + \frac{L}{1000} - 0,8 \frac{x}{L}$	1-0.8x/L
Aft end forward of amid-ships	All tiers, when: $x/L > 0,5$	$0,5 + \frac{L}{1000} - 0,4 \frac{x}{L}$	0.8-0.4x/L

- $b_1$  : Breadth of deckhouse, in m, at the position considered, to be taken not less than 0,25  $B_1$
- $B_1$  : Actual maximum breadth of ship on the exposed weather deck, in m, at the position considered
- $b$  : Coefficient defined in Tab 6
- $f$  : Coefficient defined in Tab 7
- $z$  : distance between base line and the position considered, in m
- $T$  : summer waterline in m.
- $X$  : indicated in Tab 5 and Tab 6 is the co-ordinate, in m, of the calculation point with respect to the reference co-ordinate system defined in Pt B, Ch 1, Sec 2, [4].

**Table 6 : Coefficient b (1/7/2011)**

$\frac{x}{L} \leq 0,45$	$1 + \left( \frac{\frac{x}{L} - 0,45}{C_B + 0,2} \right)^2$
$\frac{x}{L} > 0,45$	$1 + 1,5 \left( \frac{\frac{x}{L} - 0,45}{C_B + 0,2} \right)^2$
<p>(1) For deckhouse sides, the deckhouse is to be subdivided into parts of approximately equal length, not exceeding 0,15L each, and x is to be taken as the co-ordinate of the centre of each part considered.</p> <p><b>Note 1:</b> <math>C_B</math> : Block coefficient, with <math>0,6 \leq C_B \leq 0,8</math></p>	

**Table 7 : Coefficient f (1/7/2011)**

Length of ship, in m	f
$L < 150$	$\frac{L}{10} e^{-L/300} - \left[ 1 - \left( \frac{L}{150} \right)^2 \right]$
$150 \leq L < 300$	$\frac{L}{10} e^{-L/300}$
$L \geq 300$	11,03

The design pressure  $p$ , in  $\text{kN/m}^2$  is in any case not to be taken less than  $p_{\min}$  as defined in Tab 8 where arrangement is in accordance to Pt B, Ch 9, Sec 9 or where arrangement is in accordance to [7.3].

**Table 8 :  $p_{\min}$  (1/7/2020)**

Type of bulkhead	location	$p_{\min}$ in $\text{KN/m}^2$
Unprotect front	Lowest tier	$30 \leq 25+0.1L \leq 50$
	Second tier	$15 \leq 12.5+0.05L \leq 25$
	third tier	15
Protect front, side and aft end	Lowest and second tiers	$15 \leq 12.5+0.05L \leq 25$

**Table 9 :  $p_{\min}$  for "alternative to deadlights / storm covers" arrangement and scantling in [7.3] (1/7/2020)**

tier	$p_{\min}$ in $\text{KN/m}^2$
2 <sup>nd</sup>	35
3 <sup>rd</sup> and above	15

### 7.3 Alternative to deadlights/storm covers

#### 7.3.1 (1/7/2020)

In case the freeboard exceeds the minimum required according to the applicable International Convention on Load Lines, windows in the second tier and above may be fitted with a more robust glazing arrangement in alternative to the deadlights/storm covers required in Pt B, Ch 9, Sec 9. The more robust glazing arrangement is to be either:

- one glazing of a thickness increased by at least 40% with respect to the value  $t$  calculated according to [7.2]; or
- two glazing, each one of a thickness  $t$  calculated according to [7.2].

The supporting frames are to be strengthened comparably.

Other alternative arrangements of equivalent strength can be considered on case by case basis.

#### 7.3.2 (1/7/2020)

The Client is to ensure that the glazing arrangement in alternative to the deadlights/storm covers is acceptable to the Administration.

## 8 External glass balustrades

### 8.1 Application

#### 8.1.1 (1/1/2020)

The requirements of this paragraph apply solely to external glass balustrades, intended as barriers constructed with glass used on exposed decks.

### 8.2 Design considerations

#### 8.2.1 (1/1/2020)

External glass balustrades are not to be located in areas deemed essential for the operation of the ship. Such areas include mooring decks, lifeboat decks, external muster stations and in the vicinity of davits. Where external glass balustrades are not to be used, more traditional bulwarks or guard rails are to be fitted in accordance with Pt B, Ch 10, Sec 2.

#### 8.2.2 (1/1/2020)

External glass balustrades are to be not less than 1,0 m in height.

#### 8.2.3 (1/1/2020)

External glass balustrades are to provide water freeing areas in accordance with Pt B, Ch 9, Sec 9, [5].

### 8.3 Balustrade glasses

#### 8.3.1 (1/1/2020)

Railing with glass elements can be used provided they are made of either:

- monolithic glass with a minimum thickness of 6.0 mm, or
- laminated glass with a minimum thickness for each glass pane equal to 4 mm.

#### 8.3.2 (1/7/2024)

The thickness of the glass pane shall be calculated according to [7.2.2] using the design pressures as specified in [7.2.4] multiplied by 0.5.

When the glass is continuously supported only along two opposite sides, the coefficient  $\beta$  in [7.2.2] is to be taken equal to 0.75.

### 8.4 Balustrade stanchions minimum requirements

#### 8.4.1 (1/10/2022)

Stanchions are to be fitted, not more than 1.5 m apart for monolithic glass and 3.0 m apart for laminated glass. The stanchions are to have a minimum section modulus of  $16 \text{ cm}^3$  for a glass railing with 1.5 m stanchion distance and a minimum section modulus of  $32 \text{ cm}^3$  for a glass railing with 3.0 m stanchion distance. For intermediate distances, linear interpolation is to be applied.

The stanchions are to be rigidly fixed at their lower ends to resist rotational displacements.

These minimum requirements are intended for Grade A steel; for different metallic materials, an equivalent section modulus is to be calculated.

### 8.5 Balustrade top rail minimum requirements

#### 8.5.1 (1/1/2020)

Balustrade top rail is to be effectively attached to balustrade stanchions.

#### 8.5.2 (1/10/2022)

The top rail is to have a minimum section modulus  $Z$  in  $\text{cm}^3$  calculated as follows:

$$Z = 1.06 I^2$$

where I is the span of the top rail between stanchions, in m.

These minimum requirements are intended for Grade A steel; for different metallic materials, an equivalent section modulus is to be calculated.

## **8.6 Glass supporting structures yielding check**

### **8.6.1 (1/7/2024)**

For external glass balustrades, the glass supporting structures shall be calculated by direct calculations using the design pressures as specified in [7.2.4] and allowable stresses according to Pt B, Ch 7, Sec 3.

As an alternative to direct calculations, the glass supporting structures shall be accepted upon issuance of Type Approval Certificate (TA) based on testing. The balustrade

glass pane for testing shall be supported with a similar arrangement as the actual arrangement on board the ship. The test pressure shall be the design pressure specified in [7.2.4] multiplied by 1.1. The test is considered successful if no visible damage occurs to the glass or its supporting arrangements.

## **8.7 Impact Resistance and Containment**

### **8.7.1 (1/7/2024)**

External glass balustrades are to be subject to a prototype pendulum impact test in accordance with "EN 13049:2003 Windows - Soft and heavy body impact - Test method, safety requirements and classification" or an equivalent National or International Standard, utilizing a drop height of not less than 1.2 m. The test specimens including the retaining arrangements are to be the same as the finished installation.

## SECTION 4

## MACHINERY AND SYSTEMS

### 1 Bilge system

#### 1.1 General

##### 1.1.1 (1/7/2021)

- a) The bilge pumping system required in Pt C, Ch 1, Sec 10, [6] shall be capable of operation under all practicable conditions after a casualty, whether the ship is upright or listed. For this purpose, wing suctions shall generally be fitted except in narrow compartments at the end of the ship where one suction may be sufficient. In compartments of unusual form, additional suctions may be required.
- b) Arrangements shall be made whereby water in the compartment may find its way to the suction pipes.
- c) Where, for particular compartments, the Society is satisfied that the provisions of drainage may be undesirable, it may allow such provision to be dispensed with if damage stability calculations show that the survival capability of the ship will not be impaired.

#### 1.2 Bilge pumps

##### 1.2.1 Number and capacity of bilge pumps (1/1/2011)

Any passenger ship shall be provided with at least three power bilge pumps connected to the bilge main, one of which may be driven by the propulsion machinery. Where the bilge pump numeral is 30 or more one additional independent power pump shall be provided.

The bilge pump numeral shall be calculated as follows:

where  $P_1$  is greater than  $P$ :

$$\text{bilge pump numeral} = 72 \cdot \left[ \frac{M + 2P_1}{V + P_1 - P} \right]$$

in other cases:

$$\text{bilge pump numeral} = 72 \cdot \left[ \frac{M + 2P}{V} \right]$$

where:

- $L$  : the length of the ship (metres), as defined in the International Convention on Load Lines in force;
- $M$  : the volume of the machinery space (cubic metres), that is below the bulkhead deck; with the addition thereto of the volume of any permanent oil fuel bunkers which may be situated above the inner bottom and forward of, or abaft, the machinery space. For the purpose of this item machinery spaces are spaces between the watertight boundaries of a space containing

the main and auxiliary propulsion machinery, including boilers, generators and electric motors primarily intended for propulsion. In the case of unusual arrangements, the Administration may define the limits of the machinery spaces;

$P$  : the whole volume of the passenger and crew spaces below the bulkhead deck (cubic metres), which are provided for the accommodation and use of passengers and crew, excluding baggage, store, provision and mail rooms;

$V$  : the whole volume of the ship below the bulkhead deck (cubic metres);

$P_1$  :  $KN$ ,

where:

$N$  : the number of passengers for which the ship is to be certified; and

$K$  : 0,056  $L$

However, where the value of  $KN$  is greater than the sum of  $P$  and the whole volume of the actual passenger spaces above the bulkhead deck, the figure to be taken as  $P_1$  is that sum or two-thirds  $KN$ , whichever is the greater.

Each of the above pumps is to have a capacity not less than that required in Pt C, Ch 1, Sec 10, [6.7.4].

For use of ejectors in lieu of bilge pumps, see Pt C, Ch 1, Sec 10, [6.7.2].

##### 1.2.2 Location of bilge pumps

Where practicable, the power bilge pumps shall be placed in separate watertight compartments and so arranged or situated that these compartments will not be flooded by the same damage. If the main propulsion machinery, auxiliary machinery and boilers are in two or more watertight compartments, the pumps available for bilge service shall be distributed as far as is possible throughout these compartments.

##### 1.2.3 Availability of pumps (1/1/2011)

On a ship of 91,5 m in length and upwards or having a bilge pump numeral of 30 or more, as stated in [1.2.1], the arrangements shall be such that at least one power bilge pump will be available for use in all flooding conditions which the ship is required to withstand, as follows:

- a) one of the required bilge pumps shall be an emergency pump of a reliable submersible type having a source of power situated above the bulkhead deck, or
- b) the bilge pumps and their sources of power shall be so distributed throughout the length of the ship that at least one pump in an undamaged compartment will be available.

### 1.2.4 Draining capability

With the exception of additional pumps which may be provided for peak compartments only, each required bilge pump shall be so arranged as to draw water from any space required to be drained.

## 1.3 Direct bilge suction

### 1.3.1

- a) In passenger ships subject to subdivision regulations, independent power bilge pumps situated in machinery and/or boiler spaces shall have direct suctions from these spaces, except that not more than two such suctions shall be required in any one space.
- b) Where two or more such suctions are provided in one compartment, there shall be at least one on each side of the ship.
- c) The Society may require independent power bilge pumps situated in other spaces to have separate direct suctions.

## 1.4 Control location

### 1.4.1

- a) The spindles of the sea inlet and direct suction valves shall extend well above the engine room platform.
- b) Where the circulating pumps are driven by electric motors, their starting equipment shall be located at, or above, the level of the motors.

## 1.5 Provision against bilge system damage

### 1.5.1 Damage to the bilge system

Provision shall be made to prevent the compartment served by any bilge suction pipe being flooded in the event of the pipe being severed or otherwise damaged by collision or grounding in any other compartment. For this purpose, where the pipe is at any part situated nearer the side of the ship than one fifth of the breadth of the ship (measured at right angles to the centreline at the level of the deepest subdivision load line), or is in a duct keel, a non-return valve shall be fitted to the pipe in the compartment containing the open end.

### 1.5.2 Operation in the case of flooding

- a) Distribution boxes, cocks and valves in connection with the bilge pumping system shall be so arranged that, in the event of flooding, one of the bilge pumps may be operative on any compartment; in addition, damage to a pump or its pipe connecting to the bilge main outboard of a line drawn at one fifth of the breadth of the ship shall not put the bilge system out of action.
- b) If there is only one system of pipes common to all the pumps, the necessary valves for controlling the bilge

suctions must be capable of being operated from above the bulkhead deck.

- c) Where in addition to the main bilge pumping system an emergency bilge pumping system is provided, it shall be independent of the main system and so arranged that a pump is capable of operating on any compartment under flooding condition; in that case only the valves necessary for the operation of the emergency system need be capable of being operated from above the bulkhead deck.

### 1.5.3 Valve controls

All cocks and valves referred in [1.5.2] which can be operated from above the bulkhead deck shall have their controls at their place of operation clearly marked and shall be provided with means to indicate whether they are open or closed.

## 1.6 Bilge system for small ships

### 1.6.1 (1/1/2001)

For passenger ships not subject to subdivision regulations, less than 25 tons gross tonnage and assigned with a restricted navigation notation or engaged on voyages on which they are no farther from the nearest port than a distance corresponding to one hour's navigation, the bilge system will be specially considered by the Society in each single case.

## 2 Ballast system

### 2.1

2.1.1 Water ballast should not in general be carried in tanks intended for fuel oil. In ships in which it is not practicable to avoid putting water in fuel oil tanks, oily-water separating equipment to the satisfaction of the Society shall be fitted, or other alternative means, such as discharge to shore facilities shall be provided for disposing of the oily-water ballast.

## 3 Miscellaneous requirements

### 3.1 Steering gear

3.1.1 For steering gear arrangements without auxiliary means for steering, see Pt C, Ch 1, Sec 11, [3.5.2].

### 3.2 Oil-level gauges

3.2.1 For oil-level gauges, see Pt C, Ch 1, Sec 10, [11.6.7].

### 3.3 Watertight doors

3.3.1 For watertight doors, see Sec 2.

## SECTION 5

## ELECTRICAL INSTALLATIONS

### 1 General

#### 1.1 Application

##### 1.1.1 (1/7/2007)

As stated in Note 1 of Pt A, Ch 1, Sec 1, [1.1.2], the statutory requirements of the SOLAS Convention and/or national safety regulations, as applicable, regarding fire protection, detection and extinction (hereinafter referred to as "fire protection statutory requirements") are no longer mandatory for the purpose of classification, except where the Society carries out surveys relevant to fire protection statutory requirements on behalf of the flag Administration. In such cases, fire protection statutory requirements are considered a matter of class and therefore compliance with these requirements is also verified by the Society for classification purposes.

#### 1.2 Documentation to be submitted

**1.2.1** The documentation dealing with the electrical system for watertight door and fire door systems (see [1.1.1]) is to be submitted for approval.

#### 1.3 Electrical distribution and protection

**1.3.1** *In a passenger ship, distribution systems shall be so arranged that fire in any main vertical zone as defined in Part C, Chapter 4 will not interfere with services essential for safety in any other such zone.*

*This requirement will be met if main and emergency feeders passing through any such zone are separated both vertically and horizontally as widely as is practicable.*

**1.3.2** For generators arranged to operate in parallel and for individually operating generators, arrangements are to be made to disconnect automatically the excess load when the generators are overloaded in such a way as to prevent a sustained loss of speed. The operation of such device is to activate a visual and audible alarm.

##### 1.3.3 (1/7/2010)

*In passenger ships, supplementary lighting shall be provided in all cabins to clearly indicate the exit so that occupants will be able to find their way to the door. Such lighting, which may be connected to an emergency source of power or have a self-contained source of electrical power in each cabin, shall automatically illuminate when power to the normal cabin lighting is lost and remain on for a minimum of 30 min.*

### 2 Emergency source of electrical power and emergency installations

#### 2.1 General

**2.1.1** *A self-contained emergency source of electrical power shall be provided.*

**2.1.2** *Provided that suitable measures are taken for safeguarding independent emergency operation under all circumstances, the emergency generator may be used, exceptionally, and for short periods, to supply non-emergency circuits.*

Exceptionally, whilst the vessel is at sea, is understood to mean conditions such as:

- a) blackout situation
- b) dead ship situation
- c) routine use for testing
- d) short-term parallel operation with the main source of electrical power for the purpose of load transfer.

Unless instructed otherwise by the Society, the emergency generator may be used during lay time in port for the supply of the ship mains, provided the requirements of Pt C, Ch 2, Sec 3, [2.4] are complied with.

**2.1.3** *The electrical power available shall be sufficient to supply all those services that are essential for safety in an emergency, due regard being paid to such services as may have to be operated simultaneously.*

**2.1.4** *The emergency source of electrical power shall be capable, having regard to starting currents and the transitional nature of certain loads, of supplying simultaneously at least the services stated in [2.2.3] for the period specified, if they depend upon an electrical source for their operation.*

**2.1.5** *The transitional source of emergency electrical power, where required, is to be of sufficient capacity to supply at least the services stated in [2.2.7] for the periods specified therein, if they depend upon an electrical source for their operation.*

**2.1.6** *An indicator shall be mounted in a suitable place on the main switchboard or in the machinery control room to indicate when the batteries constituting either the emergency source of electrical power or the transitional source of emergency electrical power referred to in Pt C, Ch 2, Sec 3, [2.3.13] and Pt C, Ch 2, Sec 3, [2.3.14] are being discharged.*

**2.1.7** If the services which are to be supplied by the transitional source receive power from an accumulator battery by means of semiconductor converters, means are to be provided for supplying such services also in the event of failure



of the converter (e.g. providing a bypass feeder or a duplication of converter).

**2.1.8** *Where electrical power is necessary to restore propulsion, the capacity of the emergency source shall be sufficient to restore propulsion to the ship in conjunction to other machinery as appropriate, from a dead ship condition within 30 min. after blackout.*

For the purpose of this requirement only, the dead ship condition and blackout are both understood to mean a condition under which the main propulsion plant, boilers and auxiliaries are not in operation and in restoring the propulsion, no stored energy for starting the propulsion plant, the main source of electrical power and other essential auxiliaries is to be assumed available. It is assumed that means are available to start the emergency generator at all times.

The emergency generator and other means needed to restore the propulsion are to have a capacity such that the necessary propulsion starting energy is available within 30 minutes of blackout/dead ship condition as defined above. Emergency generator stored starting energy is not to be directly used for starting the propulsion plant, the main source of electrical power and/or other essential auxiliaries (emergency generator excluded).

For steam ships, the 30 minute time limit given in SOLAS can be interpreted as the time from blackout/dead ship condition defined above to light-off of the first boiler.

**2.1.9** *Provision shall be made for the periodical testing of the complete emergency system and shall include the testing of automatic starting arrangements.*

**2.1.10** For starting arrangements of emergency generating sets, see Pt C, Ch 1, Sec 2, [5.1].

**2.1.11** *The emergency source of electrical power may be either a generator or an accumulator battery, which shall comply with the provisions of [2.1.12] or [2.1.13], respectively.*

**2.1.12** *Where the emergency source of electrical power is a generator, it shall be:*

*(a) driven by a suitable prime mover with an independent supply of fuel having a flashpoint (closed cup test) of not less than 43°C;*

*(b) started automatically upon failure of the electrical supply to the emergency switchboard from the main source of electrical power and shall be automatically connected to the emergency switchboard; those services referred to in [2.2.7] shall then be transferred automatically to the emergency generating set. The automatic starting system and the characteristic of the prime mover shall be such as to permit the emergency generator to carry its full rated load as*

*quickly as is safe and practicable, subject to a maximum of 45 s; and*

*(c) provided with a transitional source of emergency electrical power according to [2.1.14].*

**2.1.13** *Where the emergency source of electrical power is an accumulator battery, it shall be capable of:*

*(a) carrying the emergency electrical load without recharging while maintaining the voltage of the battery throughout the discharge period within 12% above or below its nominal voltage;*

*(b) automatically connecting to the emergency switchboard in the event of failure of the main source of electrical power; and*

*(c) immediately supplying at least those services specified in [2.2.7].*

**2.1.14** *The transitional source of emergency electrical power required by [2.1.12] (c) shall consist of an accumulator battery which shall operate without recharging while maintaining the voltage of the battery throughout the discharge period within 12% above or below its nominal voltage and be so arranged as to supply automatically in the event of failure of either the main or emergency source of electrical power at least the services in [2.2.7] if they depend upon an electrical source for their operation.*

## **2.2 Distribution of electrical power**

**2.2.1** *The emergency switch board shall be supplied during normal operation from the main switchboard by an interconnector feeder which shall be adequately protected at the main switchboard against overload and short-circuit and which is to be disconnected automatically at the emergency switchboard upon failure of the main source of electrical power.*

*Where the system is arranged for feedback operation, the interconnector feeder is also to be protected at the emergency switchboard at least against short-circuit.*

**2.2.2** *In order to ensure ready availability of the emergency source of electrical power, arrangements shall be made where necessary to disconnect automatically non-emergency circuits from the emergency switchboard to ensure that power shall be available to the emergency circuits.*

**2.2.3** (1/1/2023)

*The emergency source of electrical power shall be capable of supplying simultaneously at least the following services for the periods specified hereafter, if they depend upon an electrical source for their operation:*

- a) for a period of 36 hours, emergency lighting:
- 1) at every muster and embarkation station and over the sides;
  - 2) in alleyways, stairways and exits giving access to the muster and embarkation stations;
  - 3) in all service and accommodation alleyways, stairways and exits, personnel lift cars;
  - 4) in the machinery spaces and main generating stations including their control positions;
  - 5) in all control stations, machinery control rooms, and at each main and emergency switchboard;
  - 6) at all stowage positions for firemen's outfits;
  - 7) at the steering gear; and
  - 8) at the fire pump, the sprinkler pump and the emergency bilge pump referred to in (d) below and at the starting position of their motors;
  - 9) in all cabins, unless this supplementary lighting has a self-contained source of electrical power in each cabin (see [1.3.3])
- b) for a period of 36 hours:
- 1) the navigation lights and other lights required by the International Regulations for Preventing Collisions at Sea in force; and
  - 2) on ships constructed on or after 1 February 1995 the VHF radio installation required by Regulation IV/7.1.1 and IV/7.1.2 of SOLAS Consolidated Edition 1992, and, if applicable:
    - the MF radio installation required by Regulations IV/9.1.1, IV/9.1.2, IV/10.1.2 and IV/10.1.3;
    - the ship earth station required by Regulation IV/10.1.1; and
    - the MF/HF radio installation required by Regulations IV/10.2.1, IV/10.2.2 and IV/11.1;
- c) for a period of 36 hours:
- 1) all internal communication equipment required in an emergency (see [2.2.4]);
  - 2) the shipborne navigational equipment as required by Regulation V/12: where such provision is unreasonable or impracticable the Head Office may waive this requirement for ships of less than 5,000 tons gross tonnage;
  - 3) the fire detection and fire alarm system, the fire door holding and release system (see [1.1.1]); and
  - 4) intermittent operation of the daylight signalling lamp, the ship's whistle, the manually operated call points and all internal signals (see [2.2.5]) that are required in an emergency;
- unless such services have an independent supply for the period of 36 hours from an accumulator battery suitably located for use in an emergency;

- d) for a period of 36 hours:
- 1) one of the fire pumps required by the relevant provisions of Part C, Chapter 4 (see [1.1.1]);
  - 2) the automatic sprinkler pump, if any [1.1.1]; and
  - 3) the emergency bilge pump and all the equipment essential for the operation of electrically powered remote controlled bilge valves;
- e) for the period of time required in Pt C, Ch 1, Sec 11, [2], the steering gear if required to be so supplied;
- f) for a period of half an hour:
- 1) any watertight doors required by Regulation II-1/15 to be power operated together with their indicators and warning signals;
  - 2) the emergency arrangements to bring the lift cars to deck level for the escape of persons. The passenger lift cars may be brought to deck level sequentially in an emergency.

Note 1: For ships having navigation notation "sheltered area" or "special navigation" having an area of operation at not more than 6 miles from the shore (see Pt C, Ch 2, Sec 1, [1.1.3]) and not subject to the SOLAS convention, the Society may accept that the emergency source of electrical power is capable of supplying, for a period of not less than 2 times the expected duration of the longest voyage, but not less than:

- 3 hours, or
- 30 minutes for ships having navigation notation "sheltered area",

only the following services:

- emergency lighting
- navigation lights;
- radio installation;
- internal communication equipment and general alarm system;
- fire detection and alarm system;
- the steering gear pump (where it is required to be so supplied);
- one of the fire pumps;
- power to the control, indication and alarm circuits of watertight and fire doors (where provided);
- the sprinkler pump;
- the emergency bilge pump.

#### 2.2.4 (1/7/2007)

Internal communication equipment required in an emergency generally includes:

- a) the means of communication between the navigating bridge and the steering gear compartment
- b) the means of communication between the navigating bridge and the position in the machinery space or control room from which the engines are normally controlled
- c) the means of communication which is provided between the officer of the watch and the person responsible for closing any watertight door which is not capable of being closed from a central control station
- d) the public address system or other effective means of communication throughout the accommodation, public and service spaces (see [1.1.1])
- e) the means of communication between the navigating bridge and the main fire control station.

**2.2.5 (1/7/2007)**

Internal signals required in an emergency generally include:

- a) general alarm (see [1.1.1])
- b) watertight door indication
- c) fire door indication (see [1.1.1]).

**2.2.6 (1/7/2003)**

*In a ship engaged regularly in voyages of short duration, i.e. voyages where the route is not greater than 20 nautical miles offshore or where the vessel has a class notation "Coastal Service", the Society if satisfied that an adequate standard of safety would be attained may accept a lesser period than the 36-hour period specified in [2.2.3] (b) to (e) but not less than 12 hours.*

Note 1: In ships for which SOLAS is not applicable, a reduced period of time may be accepted, but not less than three hours.

**2.2.7** *The transitional source of emergency electrical power required is to supply at least the following services if they depend upon an electrical source for their operation:*

- a) *for half an hour:*
  - 1) *the lighting required by [2.2.3] (a) and (b1);*
  - 2) *all services required by [2.2.3] (c1, 3 and 4) unless such services have an independent supply for the period specified from an accumulator battery suitably located for use in an emergency.*
- b) *It is also to supply power to close the watertight doors as required by Regulation II-1/15.7.3.3, but not necessarily all of them simultaneously, unless an independent temporary source of stored energy is provided. Power to the control, indication and alarm circuits as required by Regulation II-1/15.7.2, for half an hour.*

### **3 General emergency alarm and public address systems**

#### **3.1 Application**

**3.1.1 (1/7/2007)**

For the application of this item [3], see [1.1.1].

#### **3.2 General emergency alarm system**

**3.2.1** An electrically operated bell or klaxon or other equivalent warning system installed in addition to the ship's whistle or siren for sounding the general emergency alarm signal is to comply with the following requirements.

**3.2.2** The general emergency alarm system is to be supplemented by either a public address system complying with the requirements in [3.3] or other suitable means of communication.

**3.2.3** The entertainment sound system is to be automatically turned off when the general alarm system is activated.

**3.2.4** The system is to be continuously powered and is to have an automatic change-over to a standby power supply in case of loss of the normal power supply.

An alarm is to be given in the event of failure of the normal power supply.

**3.2.5** The system is to be powered by means of two circuits, one from the ship's main supply and the other from the emergency source of electrical power required by [2.1] and [2.2].

**3.2.6 (1/7/2002)**

The system is to be capable of operation from the navigation bridge and, except for the ship's whistle, also from other strategic points.

Note 1: Other strategic points are taken to mean those locations, other than the navigation bridge, from where emergency situations are intended to be controlled and the general alarm system can be activated. A fire control station is normally to be regarded as strategic points.

**3.2.7** The alarm is to continue to function after it has been triggered until it is manually turned off or is temporarily interrupted by a message on the public address system.

**3.2.8** The alarm system is to be audible throughout all the accommodation and normal crew working spaces and on all open decks.

**3.2.9** The minimum sound pressure level for the emergency alarm tone in interior and exterior spaces is to be 80 dB (A) and at least 10 dB (A) above ambient noise levels existing during normal equipment operation with the ship underway in moderate weather.

**3.2.10** In cabins without a loudspeaker installation, an electronic alarm transducer, e.g. a buzzer or similar, is to be installed.

**3.2.11** The sound pressure level at the sleeping position in cabins and in cabin bathrooms is to be at least 75 dB (A) and at least 10 dB (A) above ambient noise levels.

**3.2.12** For cables used for the general emergency alarm system, see Pt C, Ch 2, Sec 3, [9.6], Pt C, Ch 2, Sec 11, [5.2.1] and Pt C, Ch 2, Sec 11, [5.2.4].

**3.2.13** Electrical cables and apparatus for the general emergency alarm system and their power supply are to be arranged so that the loss of the system in any one area due to localised fire is minimised.

**3.2.14** Where the fire alarm to summon the crew operated from the navigating bridge or fire control station is part of the ship's general alarm system, it is to be capable of being sounded independently of the alarm in the passenger spaces.

#### **3.3 Public address system**

**3.3.1** The public address system is to be one complete system consisting of a loudspeaker installation which enables simultaneous broadcast of messages from the navigation bridge, and at least one other location on board for use when the navigation bridge has been rendered unavailable due to the emergency, to all spaces where crew members or passengers, or both, are normally present (accommodation

and service spaces and control stations and open decks), and to assembly stations (i.e. muster stations).

In spaces such as under deck passageways, busun's locker, hospital and pump room, the public address system is/may not be required.

**3.3.2 (1/7/2002)**

The public address system is to be arranged to operate on the main source of electrical power, the emergency source of electrical power and transitional sources of electrical power as required by [2.2].

**3.3.3** The controls of the system on the navigation bridge are to be capable of interrupting any broadcast on the system from any other location on board.

**3.3.4** Where an individual loudspeaker has a device for local silencing, an override arrangement from the control station(s), including the navigating bridge, is to be in place.

**3.3.5** The system is not to require any action by the addressee.

**3.3.6** It is to be possible to address crew accommodation and work spaces separately from passenger spaces.

**3.3.7** In addition to any function provided for routine use aboard the ship, the system is to have an emergency function control at each control station which:

- a) is clearly indicated as the emergency function,
- b) is protected against unauthorised use,
- c) automatically overrides any other input system or program, and
- d) automatically overrides all volume controls and on/off controls so that the required volume for the emergency mode is achieved in all spaces.

**3.3.8** The system is to be installed with regard to acoustically marginal conditions, so that emergency announcements are clearly audible above ambient noise in all spaces where crew members or passengers, or both, are normally present (accommodation and service spaces and control stations and open decks), and at assembly stations (i.e. muster stations).

**3.3.9** With the ship underway in normal conditions, the minimum sound pressure level for broadcasting emergency announcements is to be:

- a) in interior spaces 75 dB (A) and at least 20 dB (A) above the speech interference level, and
- b) in exterior spaces 80 dB (A) and at least 15 dB (A) above the speech interference level.

**3.3.10** The system is to be arranged to prevent feed-back or other interference.

**3.3.11** The system is to be arranged to minimise the effect of a single failure so that the emergency messages are still audible (above ambient noise levels) also in the event of failure of any one circuit or component.

**3.3.12** Each loudspeaker is to be individually protected against short-circuits.

**3.3.13** For cables used for the public address system, see Pt C, Ch 2, Sec 3, [9.6], Pt C, Ch 2, Sec 11, [5.2.1] and Pt C, Ch 2, Sec 11, [5.2.4].

**3.3.14** All areas of each fire zone are to be served by at least two dedicated loops of flame-retardant cables which are to be sufficiently separated throughout their length and supplied by two separate and independent amplifiers.

## **3.4 Combined general emergency alarm - Public address system**

**3.4.1** Where the public address system is the only means for sounding the general emergency alarm signal and the fire alarm, in addition to the requirements of [3.2] and [3.3], the following are to be satisfied:

- the system automatically overrides any other input system when an emergency alarm is required
- the system automatically overrides any volume control provided to give the required output for the emergency mode when an emergency alarm is required
- the system is arranged to minimise the effect of a single failure so that the alarm signal is still audible (above ambient noise levels) also in the event of failure of any one circuit or component, by means of the use of more than one device for generating an electronic sound signal.

## **4 Installation**

### **4.1 Section and distribution boards**

**4.1.1** Cubicles and cupboards in areas which are accessible to any passenger are to be lockable.

## **5 Type approved components**

### **5.1**

**5.1.1** Components for Low-Location Lighting systems (LLL) in passenger ship escape routes are to be type approved or in accordance with [5.1.2].

**5.1.2** Case-by-case approval based on submission of adequate documentation and execution of tests may also be granted at the discretion of the Society.

Part E  
**Service Notations**

Chapter 12

**RO-RO PASSENGER SHIPS**

---

- SECTION 1      GENERAL**
- SECTION 2      SHIP ARRANGEMENT**
- SECTION 3      HULL AND STABILITY**
- SECTION 4      MACHINERY AND SYSTEMS**
- SECTION 5      ELECTRICAL INSTALLATIONS**



# SECTION 1 GENERAL

## 1 General

### 1.1 Application

**1.1.1** Ships complying with the requirements of this Chapter are eligible for the assignment of the service notation **ro-ro passenger ship**, as defined in Pt A, Ch 1, Sec 2, [4.6.3].

**1.1.2** Ships dealt with in this Chapter are to comply with the requirements stipulated in Parts A, B, C and D of the Rules, as applicable, and with the requirements of this Chapter, which are specific to ro-ro passenger ships.

### 1.2 Summary table

**1.2.1** Table 1 indicates, for easy reference, the Sections of this Chapter dealing with requirements applicable to ro-ro passenger ships.

**Table 1 (1/7/2011)**

Main subject	Reference
Ship arrangement	Sec 2
Hull and stability	Sec 3
Machinery and systems	Sec 4
Electrical installations	Sec 5 and Ch 11, Sec 5
Automation	(1)
Fire protection, detection and extinction	(1)
(1) No specific requirements for ro-ro passenger ships are given in this Chapter.	

## SECTION 2

## SHIP ARRANGEMENT

### 1 General

#### 1.1 Application

**1.1.1** The requirements of Ch 11, Sec 2 and Ch 11, Sec 3 apply to multi-deck ships, with double bottom and, in some cases, with wing tanks up to the lowest deck above the full load waterline, intended for the carriage of:

- passengers
- vehicles which embark and disembark on their own wheels, and/or goods in or on pallets or containers which can be loaded and unloaded by means of wheeled vehicles
- railway cars, on fixed rails, which embark and disembark on their own wheels.

#### 1.2 Definitions

##### 1.2.1 Subdivision load line

*Subdivision load line is a waterline used in determining the subdivision of the ship.*

##### 1.2.2 Deepest subdivision load line

*Deepest subdivision load line is the waterline which corresponds to the greatest draught permitted by the subdivision requirements which are applicable.*

##### 1.2.3 Length $L_s$

*Length  $L_s$  of the ship is the length measured between perpendiculars taken at the extremities of the deepest subdivision load line.*

The length referred to in [2] is the length  $L_s$ .

##### 1.2.4 Bulkhead deck

*Bulkhead deck is the uppermost deck up to which the transverse watertight bulkheads are carried.*

##### 1.2.5 Margin line

*Margin line is a line drawn at least 76 mm below the upper surface of the bulkhead deck at side.*

##### 1.2.6 Passenger spaces

*Passenger spaces are those spaces which are provided for the accommodation and use of passengers, excluding baggage, store, provision and mail rooms.*

*In all cases volumes and areas are to be calculated to moulded lines.*

##### 1.2.7 Ro-ro cargo spaces (1/1/2005)

*Ro-ro cargo spaces are spaces not normally subdivided in any way and normally extending for either a substantial length or the entire length of the ship, in which motor vehicles with fuel in their tanks for their own propulsion and/or goods (packaged or in bulk, in or on rail or road cars, vehicles [including road or rail tankers], trailers, containers, pal-*

*lets, demountable tanks or in or on similar stowage units or other receptacles) can be loaded and unloaded normally in a horizontal direction.*

##### 1.2.8 Special category spaces (1/1/2005)

*Special category spaces are those enclosed vehicle spaces above or below the bulkhead deck, into and from which vehicles can be driven and to which passengers have access. Special category spaces may be arranged on more than one deck provided that the total overall clear height for vehicles does not exceed 10 m.*

### 2 General arrangement design

#### 2.1 Number and disposition of transverse watertight bulkheads

**2.1.1** Where there are less transverse bulkheads than those specified in Pt B, Ch 2, Sec 1, [1.1] or where the distance between them is considered excessive by the Society, ships are to be fitted with a system of partial bulkheads, side transverse frames and deck transverses such as to provide equivalent transverse strength.

#### 2.2 Arrangement of the collision bulkhead

##### 2.2.1 (1/7/2018)

For the arrangement of the collision bulkhead, see Pt B, Ch 2, Sec 1, [2.1].

#### 2.3 After peak bulkhead, machinery space bulkheads and sterntubes

**2.3.1** *An after peak bulkhead, and bulkheads dividing the machinery space from the cargo and passenger spaces forward and aft, are to also be fitted and made watertight up to the bulkhead deck. The after peak bulkhead may, however, be stepped below the bulkhead deck, provided the degree of safety of the ship as regards subdivision is not thereby diminished.*

**2.3.2** *In all cases sterntubes are to be enclosed in watertight spaces of moderate volume. The stern gland is to be situated in a watertight shaft tunnel or other watertight space separate from the sterntube compartment and of such volume that, if flooded by leakage through the stern gland, the margin line is not submerged.*

#### 2.4 Openings in watertight bulkheads below the bulkhead deck

##### 2.4.1 Openings in machinery spaces

*Not more than one door apart from the doors to bunkers and shaft tunnels may be fitted in each main transverse bulkhead within spaces containing the main and auxiliary*



propulsion machinery including boilers serving the needs of propulsion and all permanent bunkers. Where two or more shafts are fitted the tunnels are to be connected by an inter-communicating passage. Only one door is to be provided between the machinery space and the tunnel spaces where two shafts are fitted and only two doors where there are more than two shafts. All these doors are to be of the sliding type and are to be so located as to have their sills as high as practicable. The hand gear for operating these doors from above the bulkhead deck is to be situated outside the spaces containing the machinery.

Portable plates on bulkheads are not permitted except in machinery spaces. Such plates are always to be in place before the ship leaves port, and are not to be removed during navigation except in the case of urgent necessity at the discretion of the Master. The times of removal and replacement of any such portable plates are to be recorded in the log-book, and the necessary precautions are to be taken in replacing them to ensure that the joints are watertight. The Society may permit not more than one power-operated sliding watertight door in each main transverse bulkhead larger than 1,20 m to be substituted for these portable plates, provided these doors are closed before the ship leaves port and remain closed during navigation except in the case of urgent necessity at the discretion of the Master. These doors need not meet the requirements of complete closure by hand-operated gear in 90 seconds (see [2.6.3] e). The time of opening and closing these doors, whether the ship is at sea or in port, is to be recorded in the log-book.

#### 2.4.2 Openings in cargo spaces

Watertight doors complying with the requirements of [2.6.1] may be fitted in watertight bulkheads dividing cargo between deck spaces. Such doors may be hinged, rolling or sliding doors but are not to be remotely controlled. They are to be fitted at the highest level and as far from the shell plating as practicable, but in no case are the outboard vertical edges to be situated at a distance from the shell plating which is less than one fifth of the breadth of the ship, such distance being measured at right angles to the centreline at the level of the deepest subdivision load line. The doors accessible during the voyage, are to be fitted with a device which prevents unauthorised opening. Manholes, or access in transverse watertight bulkheads dividing a cargo space from an adjoining cargo space or from a permanent reserve bunker, may also be accepted by the Society.

#### 2.4.3 Openings in ships carrying goods vehicles and accompanying personnel

This requirement applies to ships designed or adapted for the carriage of goods vehicles and accompanying personnel where the total number of persons on board other than passengers as defined in Pt A, Ch 1, Sec 2, [4.6.2], exceeds 12.

If in such a ship the total number of passengers which include personnel accompanying vehicles does not exceed:

$$N = 12 + \frac{A}{25}$$

where:

$N$  : the maximum number of passengers for which the ship may be certified.

$A$  : the total deck area, in  $m^2$ , of spaces available for the stowage of goods vehicles,

and where the clear height at the stowage position and at the entrance to such spaces is not less than 4 m, the provisions of [2.4.2] in respect of watertight doors apply except that the doors may be fitted at any level in watertight bulkheads dividing cargo spaces.

Additionally, indicators are required on the navigating bridge to show automatically when each door is closed and all door fastenings are secured.

#### 2.4.4 Trunks and tunnels

Where trunkways or tunnels for access from crew accommodation to the stokehold, for piping, or for any other purpose are carried through main transverse watertight bulkheads, they are to be watertight and in accordance with the requirements of Pt B, Ch 4, Sec 7, [1.3]. The access to at least one end of each such tunnel or trunkway, if used as a passage at sea, is to be through a trunk extending watertight to a height sufficient to permit access above the margin line. The access to the other end of the trunkway or tunnel may be through a watertight door of the type required by its location in the ship. Such trunkways or tunnels are not to extend through the first subdivision bulkhead abaft the collision bulkhead.

Where trunkways in connection with refrigerated cargo and ventilation or forced draught trunks are carried through more than one watertight bulkhead, the means of closure at such openings are to be operated by power and be capable of being closed from a central position situated above the bulkhead deck.

Where a ventilation trunk passing through a structure penetrates the bulkhead deck, the trunk is to be capable of withstanding the water pressure that may be present within the trunk, after having taken into account the maximum heel angle allowable during intermediate stages of flooding.

In the absence of information regarding the above maximum angle of heel, the water pressure relevant to the transverse location of the ventilation trunk is to be linearly interpolated between 0,5 m at the centreline and a height corresponding to an angle of 15° from the bulkhead deck plus 0,5 m at the side shell.

#### 2.4.5 Additional requirements

In addition to [2.4.1], [2.4.2], [2.4.3], and [2.4.4], the requirements reported in [2.6.3] are to be complied with.

### 2.5 Openings in bulkheads above the bulkhead deck

#### 2.5.1 General

Measures such as the fitting of partial bulkheads or diaphragms are to be taken to limit the entry and spread of water above the bulkhead deck. When partial watertight bulkheads and diaphragms are fitted on the bulkhead deck, above or in the immediate vicinity of main subdivision bulkheads, their connections with the shell and bulkhead deck are to be watertight so as to restrict the flow of water along the deck when the ship is in a heeled damaged condition. Where the partial watertight bulkhead does not line up with

the bulkhead below, the bulkhead deck between is to be made effectively watertight.

The bulkhead deck or a deck above it is to be weathertight. The coamings of all openings in the exposed weather deck are to be of ample height and strength and are to be provided with efficient means for expeditiously closing them weathertight. Freeing ports, open rails and scuppers are to be fitted as necessary for rapidly cleaning the weather deck of water under all weather conditions.

Sidescuttles, gangway, cargo and coaling ports and other means for closing openings in the shell plating above the margin line are to be of efficient design and construction and of sufficient strength (see Pt B, Ch 9, Sec 9) having regard to the spaces in which they are fitted and their positions relative to the deepest subdivision load line.

Efficient inside deadlights, so arranged that they can be easily and effectively closed and secured watertight, are to be provided for all sidescuttles to spaces below the first deck above the bulkhead deck.

**2.5.2 Watertight integrity from the ro-ro deck (bulkhead deck) to spaces below**

In ships subject to the provisions of [2.5.3], the lowest point of all accesses that lead to spaces below the bulkhead deck is not to be less than 2,5 m above the bulkhead deck.

**2.5.3 Vehicle ramps and other accesses**

Where vehicle ramps are installed to give access to spaces below the bulkhead deck, their openings are to be closed weathertight to prevent ingress of water below, alarmed and indicated to the navigation bridge.

The Society may permit the fitting of particular accesses to spaces below the bulkhead deck provided they are necessary for the essential working of the ship, e.g. the movement of machinery and stores, subject to such accesses being

made watertight, alarmed and indicated to the navigation bridge.

**2.5.4 Open end of air pipes**

The open end of air pipes terminating within a superstructure is to be at least 1 m above the waterline when the ship heels to an angle of 15 degrees, or the maximum angle of heel during intermediate stages of flooding, as determined by direct calculation, whichever is the greater. Where no information regarding the above angle of heel is available, the open end of air pipes terminating within a superstructure is to be at least 1 m above the waterline when the ship heels to an angle of 15° or 0,5 m from the bulkhead deck, whichever is the greater.

Alternatively, air pipes from tanks other than oil tanks may discharge through the side of the superstructure. The provisions of this paragraph are without prejudice to the provisions of the International Convention on Load Lines in force.

**2.5.5 Additional requirements**

In addition to [2.5.1], [2.5.2], [2.5.3] and [2.5.4], the requirements in [2.6.4] are to be complied with.

**2.6 Doors**

**2.6.1 Requirements for doors**

The requirements relevant to the degree of tightness, as well as the operating systems, for doors complying with the prescriptions in [2.6.2] and [2.6.3] are specified in Tab 1.

**2.6.2 Construction of watertight doors**

The design, materials and construction of all watertight doors are to be to the satisfaction of the Society.

The frames of vertical watertight doors are to have no groove at the bottom in which dirt might lodge and prevent the door closing properly.

**Table 1 : Doors**

			Sliding type			Hinged type			Rolling type (cargo between deck spaces)
			remote operation indication on the bridge	indicator on the bridge	local operation only	remote operation indication on the bridge	indicator on the bridge	local operation only	
watertight	below the bulk-head deck	open at sea	X						
		normally closed (4)	X						
		remain closed (4)					X (1)		X (1) (3)
weather-tight / semi-watertight (2)	above bulk-head deck	open at sea	X			X			
		normally closed (4)		X			X		
		remain closed (4)						X	

- (1) The door is to be closed before the voyage commences.
- (2) Semi-watertight doors are required when they are located below the waterline at the equilibrium of the intermediate stages of flooding.
- (3) If the door is accessible during the voyage, a device which prevents unauthorised opening is to be fitted.
- (4) Notice to be affixed on both sides of the door: "to be kept closed at sea".

### 2.6.3 Doors in watertight bulkheads below the bulkhead deck

- a) Watertight doors are to be capable of being closed simultaneously from the central operating console at the navigation bridge in not more than 60 s with the ship in the upright position.
- b) The means of operation whether by power or by hand of any power-operated sliding watertight door are to be capable of closing the door with the ship listed to 15° either way. Consideration is to also be given to the forces which may act on either side of the door as may be experienced when water is flowing through the opening applying a static head equivalent to a water height of at least 1 m above the sill on the centreline of the door.
- c) Watertight door controls, including hydraulic piping and electrical cables, are to be kept as close as practicable to the bulkhead in which the doors are fitted, in order to minimise the likelihood of them being involved in any damage which the ship may sustain. The positioning of watertight doors and their controls are to be such that if the ship sustains damage within one fifth of the breadth of the ship, such distance being measured at right angles to the centreline at the level of the deepest subdivision load line, the operation of the watertight doors clear of the damaged portion of the ship is not impaired.
- d) All power-operated sliding watertight doors are to be provided with means of indication which show at all remote operating positions whether the doors are open or closed. Remote operating positions are only to be located at the navigating bridge and at the location where hand operation above the bulkhead deck is required by e).
- e) Each power-operated sliding watertight door:
- is to move vertically or horizontally;
  - is to be normally limited to a maximum clear opening width of 1,20 m. The Society may permit larger doors only to the extent considered necessary for the effective operation of the ship provided that other safety measures, including the following, are taken into consideration:
    - special consideration is to be given to the strength of the door and its closing appliances in order to prevent leakages;
    - the door is to be located outside the damage zone B/5;
    - the door is to be kept closed when the ship is at sea, except for limited periods when absolutely necessary as determined by the Society.
  - is to be fitted with the necessary equipment to open and close the door using electrical power, hydraulic power, or any other form of power that is acceptable to the Society;
  - is to be provided with an individual hand-operated mechanism. It is to be possible to open and close the door by hand at the door itself from either side and, in addition, close the door from an accessible position above the bulkhead deck with an all round crank motion or some other movement providing the same degree of safety acceptable to the Society. Direction of rotation or other movement is to be clearly indicated at all operating positions. The time necessary for the complete closure of the door, when operating by hand gear, may not exceed 90 s with the ship in the upright position;
- is to be provided with controls for opening and closing the door by power from both sides of the door and also for closing the door by power from the central operating console at the navigation bridge;
  - is to be provided with an audible alarm, distinct from any other alarm in the area, which is to sound whenever the door is closed remotely by power and which is to sound for at least 5 s but no more than 10 s before the door begins to move and is to continue sounding until the door is completely closed. In the case of remote hand operation it is sufficient for the audible alarm to sound only when the door is moving. Additionally, in passenger areas and areas of high ambient noise, the Society may require the audible alarm to be supplemented by an intermittent visual signal at the door;
  - is to have an approximately uniform rate of closure under power. The closure time, from the time the door begins to move to the time it reaches the completely closed position, is to in no case be less than 20 s or more than 40 s with the ship in the upright position.
- f) The electrical power required for power-operated sliding watertight doors is to be supplied from the emergency switchboard either directly or by a dedicated distribution board situated above the bulkhead deck. The associated control, indication and alarm circuits are to be supplied from the emergency switchboards either directly or by a dedicated distribution board situated above the bulkhead deck and be capable of being automatically supplied by a transitional source of emergency electrical power in the event of failure of either the main or emergency source of electrical power.
- The transitional source of emergency electrical power is to consist of an accumulator battery suitably located for use in an emergency which is to operate without recharging while maintaining the voltage of the battery throughout the discharge period within 12% above or below its nominal voltage and be of sufficient capacity and so arranged as to supply power automatically, in the event of failure of either the main or emergency source of electrical power, to control, indication and alarm circuits at least for half an hour.
- g) Power-operated sliding watertight doors are to have either:
- a centralised hydraulic system with two independent power sources each consisting of a motor and pump capable of simultaneously closing all doors. In addition, there are to be for the whole installation hydraulic accumulators of sufficient capacity to operate all the doors at least three times, i.e. closed-open-closed, against an adverse list of 15°. This operating cycle is to be capable of being carried out when the accumulator is at the pump cut-in pressure. The fluid used is to be chosen considering the temperatures liable to be encountered by the installation during its service. The power operating system

is to be designed to minimise the possibility of having a single failure in the hydraulic piping adversely affect the operation of more than one door. The hydraulic system is to be provided with a low-level alarm for hydraulic fluid reservoirs serving the power-operated system and a low gas pressure group alarm or other effective means of monitoring loss of stored energy in hydraulic accumulators. These alarms are to be audible and visual and are to be situated on the central operating console at the navigating bridge; or

- an independent hydraulic system for each door with each power source consisting of a motor and pump capable of opening and closing the door. In addition, there is to be a hydraulic accumulator of sufficient capacity to operate the door at least three times, i.e. closed-open-closed, against an adverse list of 15°. This operating cycle is to be capable of being carried out when the accumulator is at the pump cut-in pressure. The fluid used is to be chosen considering the temperatures liable to be encountered by the installation during its service. A low gas pressure group alarm or other effective means of monitoring loss of stored energy in hydraulic accumulators is to be provided at the central operating console on the navigation bridge. Loss of stored energy indication at each local operating position is to also be provided; or
- an independent electrical system and motor for each door with each power source consisting of a motor capable of opening and closing the door. The power source is to be capable of being automatically supplied by the transitional source of emergency electrical power in the event of failure of either the main or emergency source of electrical power and with sufficient capacity to operate the door at least three times, i.e. closed-open-closed, against an adverse list of 15°.

The transitional source of emergency electrical power is to consist of an accumulator battery suitably located for use in an emergency which is to operate without recharging while maintaining the voltage of the battery throughout the discharge period within 12% above or below its nominal voltage and be of sufficient capacity and so arranged as to supply power automatically, in the event of failure of either the main or emergency source of electrical power, to watertight doors, but not necessarily all of them simultaneously, unless an independent source of stored energy is provided.

For the systems specified above, provision is to be made as follows:

Power systems for power-operated watertight sliding doors are to be separate from any other power system. A single failure in the electrical or hydraulic power-operated systems excluding the hydraulic actuator may not prevent the hand operation of any door.

- h) Control handles are to be provided at each side of the bulkhead at a minimum height of 1,6 m above the floor and are to be so arranged as to enable persons passing through the doorway to hold both handles in the open

position without being able to set the power closing mechanism in operation accidentally. The direction of movement of the handles in opening and closing the door is to be in the direction of door movement and is to be clearly indicated.

- i) As far as practicable, electrical equipment and components for watertight doors are to be situated above the bulkhead deck and outside hazardous areas and spaces.
  - j) The enclosures of electrical components necessarily situated below the bulkhead deck are to provide suitable protection against the ingress of water.
  - k) Electric power, control, indication and alarm circuits are to be protected against fault in such a way that a failure in one door circuit may not cause a failure in any other door circuit. Short-circuits or other faults in the alarm or indicator circuits of a door may not result in a loss of power operation of that door. Arrangements are to be such that leakage of water into the electrical equipment located below the bulkhead deck may not cause the door to open.
  - l) A single electrical failure in the power operating or control system of a power-operated sliding watertight door may not result in a closed door opening. Availability of the power supply is to be continuously monitored at a point in the electric circuit as near as practicable to each of the motors required in g). Loss of any such power supply is to activate an audible and visual alarm at the central operating console at the navigation bridge.
  - m) The central operating console at the navigation bridge is to have a "master mode" switch with two modes of control:
    - a "local control" mode which is to allow any door to be locally opened and locally closed after use without automatic closure, and
    - a "doors closed" mode which is to automatically close any door that is open. The "doors closed" mode is to permit doors to be opened locally and is to automatically reclose the doors upon release of the local control mechanism.
- The "master mode" switch is to normally be in the "local control" mode. The "doors closed" mode is to only be used in an emergency or for testing purposes. Special consideration is to be given to the reliability of the "master mode" switch.
- n) The central operating console at the navigation bridge is to be provided with a diagram showing the location of each door, with visual indicators to show whether each door is open or closed. A red light is to indicate a door is fully open and a green light is to indicate a door is fully closed. When the door is closed remotely the red light is to indicate the intermediate position by flashing. The indicating circuit is to be independent of the control circuit for each door.
  - o) It is not to be possible to remotely open any door from the central operating console.
  - p) All watertight doors are to be kept closed during navigation. Certain watertight doors may be permitted to remain open during navigation only if considered absolutely necessary; that is, being open is determined

essential to the safe and effective operation of the ship's machinery or to permit passengers normally unrestricted access throughout the passenger area. Such determination is to be made by the Society only after careful consideration of the impact on ship operations and survivability. A watertight door permitted to remain thus open is to be clearly indicated in the ship's stability information and the damage control documentation and is always to be ready for immediate closure.

#### 2.6.4 Doors in watertight bulkheads above the bulkhead deck (1/1/2007)

##### a) General

Doors are to be capable of being opened and closed by hand locally from both sides of the doors with the ship listed to 15° to either side. If the ship is allowed to heel up to 20°, during intermediate stages of flooding, then the doors are to be capable of operation by hand with the ship listed to 20° to either side.

Position indicators are to be provided on the bridge as well as locally on both side of the doors to show that the doors are open or closed and that the dogs are fully and properly engaged.

Where the doors also serve as fire doors they are to be provided with position indicators at the fire control station and audible alarms as required for fire doors, as well as for weathertight doors. Where two doors are fitted they must be capable of independent operation remotely and from both sides of each door.

##### b) Doors normally closed at sea

In addition to a), doors not required for frequent access while at sea are to be kept normally closed and may be of either hinged or sliding type.

Doors kept normally closed are to have local operation from both sides of the doors and are to be labelled on both sides: "to be kept closed at sea".

##### c) Doors normally open at sea

Where fitted in public space for the passage of passengers and crew, the doors may be kept normally open at sea and may be either hinged or sliding type.

In addition to a), doors kept normally open at sea are to have local power operation from both sides of the door and remote closing from the bridge. Operation of these doors is to use a "master mode" switch on the bridge, so that the local control can override the remote closing feature after which the door is automatically remotely reclosed upon release of the local control mechanism.

Doors kept normally open at sea are to have audible alarms, distinct from any other alarm in the area, which sound whenever the doors are closed remotely. The alarms are to sound for at least 5 s but not more than 10 s before the doors begins to move and continue sounding until the doors are completely closed. In passenger areas and areas of high ambient noise, the audible alarms are to be supplemented by visual signals at both sides of the doors.

##### d) The following doors, located above the margin line, are to be provided with adequate means of closure and

locking devices according to a) and b) above and the requirements of Pt B, Ch 9, Sec 6, [6]:

- cargo loading doors in the shell or the boundaries of enclosed superstructures,
- bow visors fitted in the shell or the boundaries of enclosed superstructures,
- cargo loading doors in the collision bulkhead;
- weathertight ramps forming an alternative closure to those previously defined.

## 2.7 Integrity of the hull and superstructure, damage prevention and control

**2.7.1** Indicators are to be provided on the navigation bridge for all shell doors, loading doors and other closing appliances which, if left open or not properly secured, could, in the opinion of the Society, lead to flooding of a special category space or ro-ro cargo space. The indicator system is to be designed on the fail-safe principle and is to show by visual alarms if the door is not fully closed or if any of the securing arrangements are not in place and fully locked and by audible alarms if such door or closing appliances become open or the securing arrangements become unsecured. The indicator panel on the navigation bridge is to be equipped with a mode selection function "harbour/sea voyage" so arranged that an audible alarm is given on the navigation bridge if the ship leaves harbour with the bow doors, inner doors, stern ramp or any other side shell doors not closed or any closing device not in the correct position. The power supply for the indicator system is to be independent of the power supply for operating and securing the doors and is to be provided with a backup power supply.

The sensors of the indicator system are to be protected from water, ice formation and mechanical damage.

The indication panel is to be provided with a lamp test function. It is not to be possible to turn off the indicator light.

**2.7.2** Television surveillance and a water leakage detection system are to be arranged to provide an indication to the navigation bridge and to the engine control station of any leakage through inner and outer bow doors, stern doors or any other shell doors which could lead to flooding of special category spaces or ro-ro cargo spaces.

**2.7.3** Special category spaces and ro-ro cargo spaces are to be continuously patrolled or monitored by effective means, such as television surveillance, so that any movement of vehicles in adverse weather conditions and unauthorised access by passengers thereto can be detected whilst the ship is underway.

**2.7.4** Documented operating procedures for closing and securing all shell doors, loading doors and other closing appliances which, if left open or not properly secured, could, in the opinion of the Society, lead to flooding of a special category space or ro-ro cargo space, are to be kept on board and posted at an appropriate place. The operating procedures may be included in the stability information or in the damage control booklet.

**2.7.5** A closing indicator is to be fitted for the inner bow doors which constitute a prolongation of the collision bulkhead above the bulkhead deck as requested in [2.7.1].

## **2.8 Compartment arrangement**

### **2.8.1 Ballast compartments**

*Water ballast may not in general be carried in tanks intended for fuel oil. In ships in which it is not practicable to avoid putting water in fuel oil fuel, oily-water separating equipment to the satisfaction of the Society is to be fitted, or other alternative means, such as discharge to shore facilities, acceptable to the Society is to be provided for disposing of the oily-water ballast (see Pt C, Ch 1, Sec 10, [7]).*

### **2.8.2 Machinery compartments (1/1/2011)**

When longitudinal bulkheads are fitted in the machinery space, adequate self-operating arrangements are to be provided in order to avoid excessive heel after damage.

Where such arrangements are cross-flooding systems, their area is to be calculated in accordance with the requirements of IMO Res. MSC.245(83).

### **2.8.3 Passenger spaces in ro-ro ships**

No passenger spaces are permitted within the enclosed ro-ro decks.

## **3 Patrolling and monitoring**

### **3.1 Ro-ro spaces and special category spaces**

#### **3.1.1 (1/1/2005)**

Ro-ro cargo spaces and special category spaces are to be continuously patrolled or monitored by effective means, such as television surveillance, so that any movement of vehicles in adverse weather conditions and unauthorised access by passengers thereto can be detected whilst the ship is underway.

## SECTION 3

## HULL AND STABILITY

### 1 Stability

#### 1.1 Intact stability

##### 1.1.1 General

Every ro-ro passenger ship regardless of size is to be inclined upon its completion and the elements of its stability determined. The Master is to be supplied with such information satisfactory to the Society as is necessary to enable him by rapid and simple processes to obtain accurate guidance as to the stability of the ship under varying conditions of service. A copy of the stability information is to be furnished to the Society.

Where any alterations are made to a ship so as to materially affect the stability information supplied to the Master, amended stability information is to be provided. If necessary the ship is to be re-inclined.

The Society may allow the inclining test of an individual ship to be dispensed with provided basic stability data are available from the inclining test of a sister ship and it is shown to the satisfaction of the Society that reliable stability information for the exempted ship can be obtained from such basic data.

##### 1.1.2 Periodical lightweight check

At periodical intervals not exceeding five years, a lightweight survey is to be carried out on all ro-ro passenger ships to verify any changes in lightship displacement and longitudinal centre of gravity. The ship is to be re-inclined whenever, in comparison with the approved stability information, a deviation from the lightship displacement exceeding 2% or a deviation of the longitudinal centre of gravity exceeding 1% of  $L_s$  is found, or anticipated.

##### 1.1.3 Standard requirements

In addition to Pt B, Ch 3, Sec 2, [2] the requirements in [1.1.4] to [1.1.7] are to be complied with for the loading conditions defined in Pt B, Ch 3, App 2, [1.2.1] and Pt B, Ch 3, App 2, [1.2.9].

##### 1.1.4 Crowding of passengers (1/7/2010)

The requirements of Ch 11, Sec 3, [1.1.3] apply.

##### 1.1.5 Maximum turning angle (1/7/2010)

The requirements of Ch 11, Sec 3, [1.1.4] apply.

##### 1.1.6 Anti-rolling devices

Where anti-rolling devices are installed in a ship, the Society is to be satisfied that the above criteria can be maintained when the devices are in operation.

##### 1.1.7 Stability booklet for ro-ro ships

The stability booklet of ro-ro ships is to contain information concerning the importance of securing and maintaining all closure watertight integrity, due to the rapid loss of stability which may result when water enters the vehicle deck and the fact that capsize can rapidly occur.

### 2 Structure design principles

#### 2.1 General

**2.1.1** Wood sheathing is recommended for caterpillar trucks and unusual vehicles.

It is recommended that a piece of wood of suitable thickness should be fitted under each crutch in order to distribute the mass over the plate and the nearest stiffeners.

#### 2.2 Hull structure

##### 2.2.1 Framing

In general, the strength deck and the bottom are to be longitudinally framed.

Where a transverse framing system is adopted for such ships, it is to be considered by the Society on a case by case basis.

##### 2.2.2 Side structures

Where decks are fitted with ramp openings adjacent to the ship's side, special consideration is to be given to the supports for the side framing.

### 3 Design loads

#### 3.1 Wheeled loads

**3.1.1** The wheeled loads induced by vehicles are defined in Pt B, Ch 5, Sec 6, [6].

#### 3.2 Accommodation

##### 3.2.1 Lowest 0,5 m of bulkheads forming vertical division along escape routes

The still water and inertial pressures transmitted to the structures belonging to lowest 0,5 m of bulkheads and other partitions forming vertical divisions along escape routes are to be obtained, in  $\text{kN/m}^2$ , as specified in Pt B, Ch 5, Sec 6, [7], where the value  $p_s$  is to be taken not less than  $1,5 \text{ kN/m}^2$  to allow them to be used as walking surfaces from the side of the escape route with the ship at large angles of heel.

## 4 Hull girder strength

### 4.1 Basic criteria

#### 4.1.1 Strength deck

In addition to the requirements in Pt B, Ch 6, Sec 1, [2.2], the contribution of the hull structures up to the strength deck to the longitudinal strength is to be assessed through a finite element analysis of the whole ship in the following cases:

- when the size of openings in the side shell and/or longitudinal bulkheads located below the deck assumed by the Designer as the strength deck decrease significantly the capability of the plating to transmit shear forces to the strength deck
- when the ends of superstructures which are required to contribute to longitudinal strength may be considered not effectively connected to the hull structures in way.

## 5 Hull scantlings

### 5.1 Plating

#### 5.1.1 Minimum net thicknesses (1/7/2015)

The net thickness of the inner bottom, side, weather strength deck and external balcony plating is to be not less than the values given in Tab 1.

**Table 1 : Minimum net thickness of the inner bottom, side, weather strength deck and external balcony plating (1/7/2015)**

Plating	Minimum net thickness, in mm
Inner bottom outside engine room	$2,0 + 0,02 L k^{1/2} + 4,5 s$
Side <ul style="list-style-type: none"> <li>• below freeboard deck</li> <li>• between freeboard deck and strength deck</li> </ul>	$2,1 + 0,028 L k^{1/2} + 4,5 s$ $2,1 + 0,013 L k^{1/2} + 4,5 s$
Weather strength deck and trunk deck	$2,2 k^{1/2} + 2,1 + s$
External balconies	$2,2 k^{1/2} + 2,1 + s$
<b>Note 1:</b>	
k	: Material factor for steel, defined in Pt B, Ch 4, Sec 1, [2.3].
s	: Length, in m, of the shorter side of the plate panel.

#### 5.1.2 Deck plating in way of side doors and stern doors (1/12/2008)

The plating net thickness of all decks in way of the position of side doors and stern doors is to be increased over a length of at least 1/3 of the door width.

This increase in net thickness is to be not less than 50% and the resulting thickness is not required to be greater than 8,0 mm.

### 5.1.3 Plating under wheeled loads

The net thickness of plating subjected to wheeled loads is to be obtained according to Pt B, Ch 7, Sec 1 or Pt B, Ch 8, Sec 3, as applicable.

### 5.1.4 Lowest 0,5 m of bulkheads forming vertical division along escape routes

The net thickness of plating belonging to the lowest 0,5 m of bulkheads and other partitions forming vertical divisions along escape routes is to be obtained according to Pt B, Ch 7, Sec 1 or Pt B, Ch 8, Sec 3, as applicable, where the loads are defined in Part B, Chapter 5 or Pt B, Ch 8, Sec 1, as applicable, and in [3.2.1].

## 5.2 Ordinary stiffeners

### 5.2.1 Stiffeners under wheeled loads

The net scantlings of ordinary stiffeners subjected to wheeled loads are to be obtained according to Pt B, Ch 7, Sec 2 or Pt B, Ch 8, Sec 4, as applicable.

### 5.2.2 Lowest 0,5 m of bulkheads forming vertical division along escape routes

The net scantlings of ordinary stiffeners belonging to the lowest 0,5 m of bulkheads and other partitions forming vertical divisions along escape routes are to be obtained according to Pt B, Ch 7, Sec 2 or Pt B, Ch 8, Sec 4, as applicable, where the loads are defined in Part B, Chapter 5 or Pt B, Ch 8, Sec 1, as applicable, and in [3.2.1].

## 5.3 Primary supporting members

### 5.3.1 Double bottom structures

In ships where pillars are widely spaced and transmit very high loads to the double bottom, the net scantlings of double bottom structures are to be considered by the Society on a case-by-case basis, taking into account the results of direct calculations to be carried out according to the criteria in Pt B, Ch 7, App 1.

Where deemed necessary, on the basis of the above results, additional floors and bottom girders may be required.

### 5.3.2 Primary supporting members under wheeled loads

The net scantlings of primary supporting members subjected to wheeled loads are to be obtained according to Pt B, Ch 7, Sec 3 and Pt B, Ch 7, App 2 or Pt B, Ch 8, Sec 5, as applicable.

### 5.3.3 Lowest 0,5 m of bulkheads forming vertical division along escape routes

The net scantlings of primary supporting members belonging to the lowest 0,5 m of bulkheads and other partitions forming vertical divisions along escape routes are to be obtained according to Pt B, Ch 7, Sec 3 or Pt B, Ch 8, Sec 5, as applicable, where the loads are defined in Part B, Chapter 5 or Pt B, Ch 8, Sec 1, as applicable, and in [3.2.1].



## 6 Other structures

### 6.1 Superstructures and deckhouses

#### 6.1.1 (1/7/2010)

*Where a ventilation trunk passing through a structure penetrates the bulkhead deck, the trunk is to be capable of withstanding the water pressure that may be present within the trunk, after having taken into account the maximum heeling angle allowable during intermediate stages of flooding, in accordance with Reg. II-1/7-2 of SOLAS Convention.*

**6.1.2** *Where all or part of the penetration of the bulkhead deck is on the main ro-ro deck, the trunk is to be capable of withstanding impact pressure due to internal water motions (sloshing) of water trapped in the ro-ro deck, to be calculated according to the applicable formulae in Pt B, Ch 5, Sec 6, [2].*

### 6.2 Bow doors and inner doors

**6.2.1** The requirements applicable to bow doors and inner doors are defined in Pt B, Ch 9, Sec 5.

### 6.3 Side doors and stern doors

**6.3.1** Side doors may be either below or above the freeboard deck.

Stern doors are to be situated above the freeboard deck.

**6.3.2** The requirements applicable to side doors and stern doors are defined in Pt B, Ch 9, Sec 6.

**6.3.3** The requirements in [6.3.4] to [6.3.7] apply to doors in the boundary of ro-ro cargo spaces or special category spaces, as defined in Sec 2, [1.2.7] and Sec 2, [1.2.8] respectively, through which such spaces may be flooded.

**6.3.4** Separate indicator lights and audible alarms are to be provided on the navigation bridge and on the operating panel to show that the doors are closed and that their securing and locking devices are properly positioned.

The indication panel is to be provided with a lamp test function. It is not to be possible to turn off the indicator light.

**Table 2 : Equipment**

Equipment number EN A < EN ≤ B		Stockless anchors		Stud link chain cables for anchors			
		N	Mass per anchor, in kg	Total length, in m	Diameter, in mm		
A	B				Q1	Q2	Q3
19	22	1	21	65	7		
22	25	1	27	70	7		
25	30	1	32	70	8		
30	35	1	37	75	8		
35	40	1	43	75	9		
40	45	1	53	80	10		
45	50	1	64	82,5	11		
50	60	1	80	82,5	11	10	
60	70	1	90	82,5	12,5	11	
70	80	1	100	110	12,5	11	10
80	90	1	120	110	14	12,5	11
90	100	1	140	110	14	12,5	11
100	110	1	160	110	16	14	12,5
110	120	1	180	110	16	14	12,5
120	130	1	200	110	16	14	12,5
130	140	1	240	110	17,5	16	14
140	150	1	260	137,5	17,5	16	14
150	175	1	300	137,5	19	17,5	16
175	205	1	360	137,5	20,5	17,5	16
205	240	1	420	137,5	22	19	17,5
240	280	1	480	137,5	24	20,5	19
280	320	1	575	165	26	22	20,5
320	360	1	660	165	28	24	22
360	400	1	700	165	30	26	22
400	450	1	780	165	30	26	24
450	500	1	900	192,5	32	28	26
500	550	1	1020	192,5	34	30	26
550	600	1	1140	192,5	36	32	28
600	660	2	1200	385	38	32	30
660	720	2	1295	385	40	34	30
720	780	2	1440	440	42	36	32
780	840	2	1500	440	42	36	32
840	910	2	1595	440	44	38	34
910	980	2	1740	440	46	40	36
980	1060	2	1920	440	48	42	36

**6.3.5** The indicator system is to be designed on the fail-safe principle and is to show by visual alarms if the door is not fully closed and not fully locked and by audible alarms if securing devices become open or locking devices become unsecured.

The power supply for the indicator system is to be independent of the power supply for operating and closing the doors and is to be provided with a backup power supply.

The sensors of the indicator system are to be protected from water, ice formation and mechanical damage.

**6.3.6** The indication panel on the navigation bridge is to be equipped with a mode selection function "harbour/sea voyage", so arranged that an audible alarm is given if the vessel leaves harbour with the doors not closed and with any of the securing devices not in the correct position.

**6.3.7** A water leakage detection system with audible alarm and television surveillance is to be arranged to provide an indication to the navigation bridge and to the engine control room of leakage through the inner door.

## 6.4 Movable decks and inner ramps

**6.4.1** The requirements applicable to movable decks and inner ramps are defined in Pt B, Ch 9, Sec 8, [1].

## 6.5 External ramps

**6.5.1** The requirements applicable to external ramps are defined in Pt B, Ch 9, Sec 8, [2].

# 7 Hull outfitting

## 7.1 Equipment

### 7.1.1 Number of mooring lines

The specific requirements in Pt B, Ch 10, Sec 4, [3.5] for ships with the service notation **ro-ro passenger ship** are to be complied with.

### 7.1.2 Ships having $L \leq 30$ m and navigation notation other than unrestricted navigation

For ships having  $L \leq 30$  m and navigation notation other than **unrestricted navigation**:

- the equipment in stockless anchor and chain cables (or ropes according to Pt B, Ch 10, Sec 4, [3.3.5]) may be obtained from Tab 2
- the equipment in mooring lines of wire or natural fibre may be obtained from Tab 3.

**Table 3 : Mooring lines (1/1/2022)**

Equipment number EN $A < EN \leq B$		Mooring lines		
A	B	N	Length of each line, in m	Ship Design Minimum Breaking Load, in kN
19	50	2	40	32
50	70	3	40	34
70	90	3	50	37
90	110	3	55	39
110	130	3	55	44
130	150	3	60	49
150	175	3	60	54

## SECTION 4

## MACHINERY AND SYSTEMS

### 1 Application

#### 1.1

##### 1.1.1 (1/7/2011)

The application of item [3] to ships classed for restricted navigation will be specially considered by the Society in each single case.

### 2 Bilge system

#### 2.1 General

##### 2.1.1 (1/7/2011)

In addition to the requirements of the following paragraphs, ro-ro passenger ships are to comply with the requirements set out in Ch 11, Sec 4.

### 3 Scuppers and sanitary discharges

#### 3.1 Drainage of vehicle, ro-ro spaces and special category spaces intended for the carriage of motor vehicles with fuel in their tanks for their own propulsion

##### 3.1.1 Prevention of build-up of free surfaces (1/7/2011)

*In cargo spaces intended for the carriage of motor vehicles with fuel in their tanks for their own propulsion, when fixed pressure water-spraying systems are fitted, in view of the serious loss of stability which could arise due to large quantities of water accumulating on the deck or decks during the operation of the fixed pressure water-spraying system, the following arrangements are to be provided:*

- a) *in the spaces above the bulkhead deck, scuppers are to be fitted so as to ensure that such water is rapidly discharged directly overboard, taking into account the requirements contained in the guidelines developed by IMO (see Note 1);*
- b) *in ro-ro passenger ships, discharge valves for scuppers, fitted with positive means of closing operable from a position above the bulkhead deck in accordance with the requirements of the International Convention on Load Lines in force, are to be kept open while the ships are at sea;*
- c) *any operation of valves referred to in paragraph b) is to be recorded in the log-book;*
- d) *in the spaces below the bulkhead deck, the Society may require pumping and drainage facilities to be provided additional to the requirements of Pt C, Ch 1, Sec 10;*

*In such case, the drainage system is to be sized to remove no less than 125% of the combined capacity of both the water-spraying system pumps and the required*

*number of fire hose nozzles, taking into account the guidelines developed by IMO (see Note 2). The drainage system valves are to be operable from outside the protected space at a position in the vicinity of the extinguishing system controls. Bilge wells are to be of sufficient holding capacity and are to be arranged at the side shell of the ship at a distance from each other of not more than 40 m in each watertight compartment;*

- e) *for closed vehicles and ro-ro spaces and special category spaces, where fixed pressure water-spraying systems are fitted, means are to be provided to prevent the blockage of drainage arrangements, taking into account the guidelines developed by IMO (see Note 1).*

*Note 1: see Resolution MSC.1/Circ. 1320 "Guidelines for the drainage of fire-fighting water from closed vehicle and ro-ro spaces and special category spaces of passenger and cargo ships"*

*Note 2: see Resolution A.123(V) "Recommendation On Fixed Fire-Extinguishing Systems For Special Category Spaces".*

#### 3.2 Scupper draining

##### 3.2.1 (1/7/2011)

Scuppers from cargo spaces intended for the carriage of motor vehicles with fuel in their tanks for their own propulsion are not to be led to machinery or other places where sources of ignition may be present.

### 4 Sounding pipes

#### 4.1 General

##### 4.1.1 (1/7/2011)

Requirements stipulated in Pt C, Ch 1, Sec 10, [9.2] apply except that sounding pipes used in flammable (except lubricating) oil systems may terminate in the ro-ro space on condition that the following provisions are satisfied:

- a) an oil-level gauge meeting the provisions in Pt C, Ch 1, Sec 10, [2.9.2] is additionally fitted;
- b) the sounding pipes terminate in locations remote from ignition hazards unless precautions are taken, such as the fitting of effective screens, to prevent the fuel oil from coming into contact with a source of ignition in the case of spillage through the terminations of the sounding pipes;
- c) the terminations of sounding pipes are fitted with self-closing blanking devices and with a small diameter self-closing control cock located below the blanking device for the purpose of ascertaining before the blanking device is opened that fuel oil is not present. Provision is to be made so as to ensure that any spillage of fuel oil through the control cock involves no ignition hazard.

Where sounding pipe termination is above the bulkhead or freeboard deck, a flush type sounding head may be accepted by the Society on a case-by-case basis.

## SECTION 5

## ELECTRICAL INSTALLATIONS

### 1 General

#### 1.1 Documentation to be submitted

**1.1.1** In addition to the documentation requested in Pt C, Ch 2, Sec 1, Tab 1, the following are to be submitted for approval:

- a) plan of hazardous areas
- b) document giving details of types of cables and safety characteristics of the equipment installed in hazardous areas
- c) diagrams of indicator systems for shell doors, loading doors and similar appliances, television surveillance or water leakage detection systems
- d) diagrams of the supplies to the supplementary emergency lighting systems.

#### 1.2 Safety characteristics

**1.2.1** The explosion group and temperature class of electrical equipment of a certified safe type for use with explosive petrol-air mixtures are to be at least IIA and T3.

### 2 Supplementary emergency lighting

#### 2.1

**2.1.1** *In addition to the emergency lighting required in Ch 11, Sec 5, [2.2], on every passenger ship with ro-ro cargo spaces or special category spaces:*

- a) *all passenger public spaces and alleyways shall be provided with supplementary electric lighting that can operate for at least three hours when all other sources of electrical power have failed and under any condition of heel. The illumination provided shall be such that the approach to the means of escape can be readily seen. The source of power for the supplementary lighting shall consist of accumulator batteries located within the lighting units that are continuously charged, where practicable, from the emergency switchboard. Alternatively, any*

*other means of lighting which is at least as effective may be accepted by the Society. The supplementary lighting shall be such that any failure of the lamp will be immediately apparent. Any accumulator battery provided shall be replaced at intervals having regard to the specified service life in the ambient conditions that they are subject to in service;*

- b) *a portable rechargeable battery operated lamp shall be provided in every crew space alleyway and recreational space and every working space which is normally occupied unless supplementary emergency lighting, as required in (a), is provided.*

### 3 Installation

#### 3.1 Installations in special category spaces situated above the bulkhead deck

**3.1.1** On any deck or platform, if fitted, on which vehicles are carried and on which explosive vapours might be expected to accumulate, except platforms with openings of sufficient size permitting penetration of petrol gases downwards, electrical equipment and cables are to be installed at least 450 mm above the deck or platform.

Electrical equipment is to be as stated in Pt C, Ch 2, Sec 3, [10.1.6] and electrical cables as stated in Pt C, Ch 2, Sec 3, [10.2.3].

**3.1.2** Where the installation of electrical equipment and cables at less than 450 mm above the deck or platform is deemed necessary for the safe operation of the ship, the electrical equipment is to be of a certified safe type as stated in Pt C, Ch 2, Sec 3, [10.1.5] and the electrical cables are to be as stated in Pt C, Ch 2, Sec 3, [10.2.2].

**3.1.3** Electrical equipment and cables in exhaust ventilation ducts are to be as stated in [3.1.2].

**3.1.4** The requirements in this item are summarised in Tab 1.

**Table 1 : Electrical equipment permitted in special category spaces above the bulkhead deck (1/1/2022)**

Hazardous area	Spaces		Electrical equipment
	No.	Description	
Zone 1	1	Areas at less than 450 mm above the deck or platforms for vehicles, if fitted, without openings of sufficient size permitting penetration of petrol gases downward.	a) any type that may be considered for zone 0 b) certified intrinsically safe apparatus Ex(ib) c) simple electrical apparatus and components (e.g. thermocouples, photocells, strain gauges, junction boxes, switching devices), included in intrinsically-safe circuits of category "ib" not capable of storing or generating electrical power or energy in excess of limits stated in the relevant rules, d) certified flameproof Ex(d) e) certified pressurised Ex(p) f) certified increased safety Ex(e) g) certified encapsulated Ex(m) h) certified sand filled Ex(q) i) certified specially Ex(s) j) cables sheathed with at least one of the following: <ul style="list-style-type: none"> <li>• a non-metallic impervious sheath in combination with braiding or other metallic covering</li> <li>• copper or stainless steel sheath (for mineral insulated cables only).</li> </ul>
Zone 1	2	Exhaust ventilation ducts.	As stated under item 1.
Zone 2	3	<ul style="list-style-type: none"> <li>• areas above a height of 450 mm from the deck</li> <li>• areas above a height of 450 mm from each platform for vehicles, if fitted, without openings of sufficient size permitting penetration of petrol gases downward</li> <li>• areas above platforms for vehicles, if fitted, with openings of sufficient size permitting penetration of petrol gases downward.</li> </ul>	a) any type that may be considered for zone 1 b) tested specially for zone 2 (e.g. type "n" protection) c) pressurised, d) encapsulated e) the type which ensures the absence of sparks and arcs and of "hot spots" during its normal operation (electrical equipment having an enclosure of at least IP55) f) cables sheathed with at least a non-metallic external impervious sheath.

### 3.2 Installations in special category spaces situated below the bulkhead deck

**3.2.1** Any electrical equipment installed is to be as stated in Pt C, Ch 2, Sec 3, [10.1.5] and electrical cables are to be as stated in Pt C, Ch 2, Sec 3, [10.2.2].

**3.2.2** Electrical equipment and cables in exhaust ventilation ducts are to be as stated in [3.2.1].

**3.2.3** The requirements in this item are summarised in Tab 2.

### 3.3 Installations in cargo spaces other than special category spaces intended for the carriage of motor vehicles

**3.3.1** The requirements for installations in special category spaces situated below the bulkhead deck, as stated in [3.2], apply.

**3.3.2** All electric circuits terminating in cargo holds are to be provided with multipole linked isolating switches located outside the holds. Provision is to be made for locking in the off position.

This requirement does not apply to safety installations such as fire, smoke or gas detection systems.

## 4 Type approved components

### 4.1

**4.1.1** Accumulator lamps for the supplementary electric lighting, alarm systems for closing devices of openings and water leakage detection systems if of electronic type, and television surveillance systems are to be type approved or in accordance with [4.1.2].

**4.1.2** Case-by-case approval based on submission of adequate documentation and execution of tests may also be granted at the discretion of the Society.

**Table 2 : Electrical equipment permitted in special category spaces below the bulkhead deck**

Hazardous area	Spaces		Electrical equipment
	No.	Description	
Zone 1	1	Special category spaces.	a) any type that may be considered for zone 0 b) certified intrinsically safe apparatus Ex(ib) c) simple electrical apparatus and components (e.g. thermocouples, photocells, strain gauges, junction boxes, switching devices), included in intrinsically-safe circuits of category "ib" not capable of storing or generating electrical power or energy in excess of limits stated in the relevant rules, d) certified flameproof Ex(d) e) certified pressurised Ex(p) f) certified increased safety Ex(e) g) certified encapsulated Ex(m) h) certified sand filled Ex(q) i) certified specially Ex(s) j) cables sheathed with at least one of the following: <ul style="list-style-type: none"> <li>• a non-metallic impervious sheath in combination with braiding or other metallic covering</li> <li>• copper or stainless steel sheath (for mineral insulated cables only).</li> </ul>
Zone 1	2	Exhaust ventilation ducts.	As stated under item 1.





## SHIPS FOR DREDGING ACTIVITY

---

**SECTION 1      GENERAL**

**SECTION 2      HULL AND STABILITY**

**SECTION 3      MACHINERY AND DREDGING SYSTEMS**



# SECTION 1 GENERAL

## 1 General

### 1.1 Application

**1.1.1** Ships complying with the requirements of this Chapter are eligible for the assignment of one of the following service notations:

- dredger
- hopper dredger
- hopper unit
- split hopper dredger
- split hopper unit

as defined in Pt A, Ch 1, Sec 2, [4.7].

**1.1.2** Ships dealt with in this Chapter are to comply with the requirements stipulated in Parts A, B, C and D of the Rules, as applicable, and with the requirements of this Chapter, which are specific to ships for dredging activities.

### 1.2 Summary table

**1.2.1** Tab 1 indicates, for ready reference, the Sections of this Chapter containing specific requirements applicable to ships for dredging activities.

**Table 1**

Main subject	Reference
Ship arrangement	(1)
Hull and stability	Sec 2
Machinery and dredging system	Sec 3
Electrical installations	(1)
Automation	(1)
Fire protection, detection and extinction	(1)
(1) No specific requirements for ships for dredging activities are given in this Chapter.	

## SECTION 2 HULL AND STABILITY

### Symbols

T	: Navigation draught, in m, corresponding to the international freeboard
T <sub>D</sub>	: Dredging draught, in m, corresponding to the dredging freeboard
C	: Wave parameter defined in Pt B, Ch 5, Sec 2 or Pt B, Ch 8, Sec 1, as applicable
k	: Material factor for steel, defined in Pt B, Ch 4, Sec 1, [2.3]
n, n <sub>1</sub>	: Navigation coefficients, defined in Pt B, Ch 5, Sec 1, [2.6] or Pt B, Ch 8, Sec 1, [1.5], as applicable
n <sub>D</sub>	: Navigation coefficient in dredging situation, defined in [3.3.1]
s	: Spacing, in m, of ordinary stiffeners
δ	: Specific gravity of the mixture of sea water and spoil, taken equal to: $\delta = \frac{P_D}{V_D}$
P <sub>D</sub>	: Maximum mass, in t, of the spoil contained in the hopper space
V <sub>D</sub>	: Volume of the hopper space, in m <sup>3</sup> , limited to the highest weir level
g	: Gravity acceleration, in m/s <sup>2</sup> : g = 9,81 m/s <sup>2</sup>
ℓ <sub>p</sub>	: Length, in m, of the hopper well
a	: Distance from the bottom to the sealing joint located at the lower part of the hopper well, in m
h <sub>1</sub>	: Distance, in m, from spoil level to base line when working at the dredging freeboard (see Fig 8)
h <sub>2</sub>	: Distance, in m, from spoil level to base line when working at the international freeboard (see Fig 8)
h <sub>4</sub>	: Distance, in m, from the lowest weir level to base line
T <sub>3</sub>	: Navigation draught, in m, with well filled with water up to waterline
T <sub>4</sub>	: Navigation draught, in m, with well filled with water up to the lowest weir level
R <sub>eH</sub>	: Minimum yield stress, in N/mm <sup>2</sup> , of the material
R <sub>m</sub>	: Minimum ultimate tensile strength, in N/mm <sup>2</sup> , of the material.

### 1 Stability

#### 1.1 Intact stability

##### 1.1.1 General (1/7/2006)

In addition to the requirements of Pt B, Ch 3, Sec 2, dredgers are to comply with the provisions of [1.1.2] and [1.1.3] as applicable.

##### 1.1.2 Intact stability (1/7/2006)

###### a) Loading conditions

In the working condition, dredging equipment is to be considered positioned so as to produce the most severe combination of inclining moment and/or initial metacentric height. In particular, for grab dredgers, the mass, in t, of the dredged materials contained in the grab of volume **V**, in m<sup>3</sup>, is to be considered equal to 1,6 **V**; for bucket dredgers the mass, in t, contained in each bucket of volume **V**, in m<sup>3</sup>, of the top of the chain is to be considered equal to 2 **V**. For suction pipes of trailing suction dredgers, the mass of the dredged spoil is to be considered equal to 1,3 t/m<sup>3</sup>.

Bucket dredgers are generally not allowed to proceed to sea without first dismantling the dredging equipment.

For the calculation of displacement, the volumes of hoppers and wells intended for the carriage of sand and spoil, even if closed in their lower part by means of non-watertight doors, are to be considered as part of the ship's body and the weight of the water within, when there is no cargo, is to be considered as additional cargo. On the other hand, wells for the arrangement of bucket chains, cutter heads or ladder pumps are to be considered as buoyancy losses.

###### b) Influence of free surfaces

1) In the calculation of initial metacentric height, the effects of free surfaces may be disregarded when the mass density of spoil is greater than 1 t/m<sup>3</sup>; otherwise, they are assumed to be fluid cargoes.

2) In the calculation of righting levers, account is to be taken of the shifting of cargo that occurs in way of the various angles of heel of the dredger, considering any variation in displacement and the position of the centre of gravity due to the discharge of mud and the re-entry of sea water. The angle of shifting of the cargo q<sub>R</sub> is to be assumed as a function of the angle of heel q<sub>G</sub> and the mass density γ, in t/m<sup>3</sup>, according to the following formulas:

$$\theta_R = \theta_G \quad \text{for } \gamma \leq 1$$

$$\theta_R = (3 - \gamma) \cdot \theta_G / 2 \text{ for } 1 < \gamma < 3$$

$$\theta_R = 0 \text{ for } \gamma \geq 3$$

For  $\gamma \geq 3$ , righting levers are to be calculated with constant displacement and without considering the shifting of the centre of gravity of the dredged materials contained in the wells.

In the case of emptied dredgers, when the well is kept in communication with the sea, the calculations are to be carried out without taking into account the water level in the well or the associated free surface.

With reference to Fig 1, an example is given of the calculation of righting levers.

The righting lever is obtained from the following formula:

$$NK \sin \theta_G - G'K \sin \theta_G$$

where:

$NK \sin \theta_G$  = righting lever obtained from the cross-curves

$$G'K \sin \theta_G = \frac{\Delta \cdot GK \sin \theta_G + P_c \cdot b + A_M \cdot a}{\Delta + P_c + A_M}$$

$\Delta$  : displacement of the dredger ready to take the load, in t

$GK$  : vertical position of the centre of gravity for the displacement  $\Delta$  from the under keel (adjusted to take into account any free surfaces in the tanks), in m

$P_c$  : mass of the cargo embarked ( $\gamma \times V$ ), in t

$V$  : volume of the cargo, in  $m^3$

- $b$  : lever of the cargo  $P$  in respect of  $K$ , in m
- $a$  : lever of the centre of gravity of the mass of water shipped in respect of  $K$ , in m
- $A_M$  : mass of water shipped, in t
- $G_P$  : position of the centre of gravity of the cargo at the angle of heel  $\theta_G$  (see Fig 1)
- $A$  : position of the centre of gravity of the water shipped (see Fig 1).

### 1.1.3 Dredging mark (1/7/2006)

#### a) General

In the case of dredging units fitted with wells and doors or similar means on the bottom for discharging spoil, at the request of the Interested Parties, a declaration may be issued stating that such units are suitable for operation at a draught greater than that based on the limitations in the International Convention on Load Lines, when they are classed for international service, or in the national load line regulations, when they are classed for national service, provided that:

- 1) the strength of the structures is adequate for the requested draught;
- 2) discharge doors on the bottom of the well can be opened in less than a minute and, unless they are gravity doors, can also be opened without the supply of power. In any case, suitable emergency arrangements are to be provided.

Both control positions enabling the doors to be opened are to be located on main deck and suitable measures are to be adopted to prevent asymmetrical discharge. For dredging units of length  $L$  less than 90 m, engaged in service less than 6 nautical miles from the coast, some relaxation of these provisions may be agreed upon;

Figure 1 (1/7/2006)

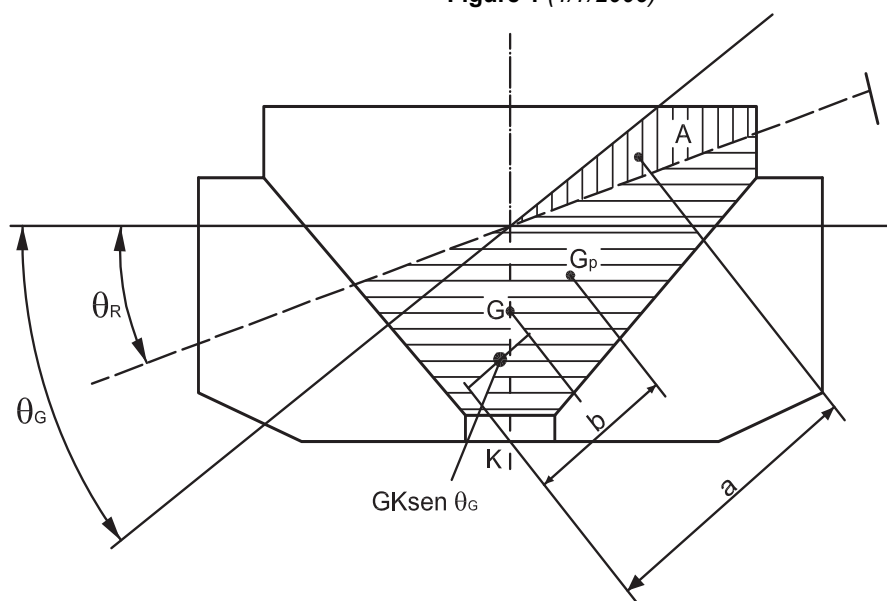

$\theta_G$  = angle of heel of the dredging unit  
 $\theta_R$  = angle of shifting stress of the cargo

- 3) a draught indicator is installed on the bridge;
  - 4) any watertight doors considered in the calculation and located below the freeboard deck are of the sliding type, operated locally from both sides and from a point situated above the freeboard deck, and indication of their opening and closure is provided on the bridge. Their operation is to be of the hydraulic type and manual operation is also to be possible;
  - 5) doors on the sides of deckhouses are made of steel or other equivalent material, permanently and effectively connected to the bulkheads, strengthened, stiffened and arranged locally such that the structure as a whole is of equivalent strength to that of a bulkhead without openings, and that the doors are weathertight when closed; this is obtained by means of gaskets, clamping devices or other equivalent means, permanently secured to the bulkheads or the doors themselves; the doors are designed so that they are operable from both sides of the bulkhead and their sill heights are not less than 380 mm above the deck;
  - 6) in addition to the conditions stipulated above, the stability characteristics fulfil those given below.
- b) Maximum permitted draught
- The maximum permitted draught, which is to be indicated by means of the special dredging mark, is in any case not to exceed that corresponding to 50% of the freeboard for a type B-100 ship calculated according to the 1966 International Convention on Load Lines.
- c) Loading conditions
- The stability characteristics are to be calculated in the full loading condition corresponding to the dredging mark with:
- 1) well completely filled, up to the top of the well or to the overflow pipes, where fitted, with spoil having homogeneous mass density;
  - 2) well partially filled with spoil having homogeneous mass density equal to 2,2 t/m<sup>3</sup>;
  - 3) well partially filled with spoil having homogeneous mass density equal to that in item 1) increased by 0,2 t/m<sup>3</sup>;
- The calculation is to be repeated with step-by-step 0,2 t/m<sup>3</sup> increases in the mass density of the spoil up till the value as per item 2) above.
- The following assumptions are to be taken into account in the calculations:
- the vessel in the upright condition with no trim;
  - the vertical position of the centre of gravity as the resultant of the loading condition specified in [1.1.2] a) with the addition of the cargo in the well indicated above;
  - the longitudinal position of the centre of gravity as the resultant of the vessel in the upright condition;
  - the actual shifting of cargo that occurs in way of the various angles of heel of the dredging unit as stated in [1.1.2] a);
  - the discharge of cargo due to the heel and, if applicable, the shipping of water from the top of the well;
  - the effects of free surfaces of spoil, assumed to be fluid cargoes in the calculation of initial metacentric height.
- d) Stability requirements
- In the loading conditions given in [1.1.3] c), the intact stability requirements laid down in Pt B, Ch 3, Sec 2 are to be fulfilled (see also the example of calculation of righting levers given in [1.1.2] b) as are the damage stability requirements in [1.1.3] e).
- e) Damage stability
- 1) General
- It is to be verified that in the damage cases in 2), at the draught corresponding to the dredging mark, the survival capability requirements in 3) are satisfied.
- 2) Damage cases
- Dredging units which operate with a draught corresponding to a freeboard less than 50% of that for a type B-60 ship are to be capable of withstanding the flooding of the machinery space as well as of any two adjacent compartments, neither of which is the machinery space.
- Dredging units which operate with a draught corresponding to a freeboard equal to or greater than 50% of that for a type B-60 ship but less than 50% of that for a type B ship are to be capable of withstanding the flooding of the machinery space or of any one compartment.
- In the damage calculations it is to be assumed that all the cargo is lost as a result of the damage and that the bottom doors remain open leaving the spaces in communication with the sea.
- The dimensional characteristics given in items below are to be taken into consideration for the damage as is any damage of a lesser extent which may have more serious effects.
- Longitudinal extent equal to the lower of the following:  $(3 + 0,03 L)$  m or 11 m.
  - Vertical extent equal to the height of the dredging unit in way of the flooded space.
- Note 1: The effect of superstructures or deckhouses located above the flooded compartment is not to be taken into account.
- Transverse extent of the damage or penetration equal to  $B/5$ , measured from the shell plating towards the inner hull, perpendicular to the plane of symmetry, at the waterline corresponding to the maximum draught level.
- 3) Survival capability requirements
- It is to be verified that in the damage cases in 2) the dredging unit in still water has sufficient residual buoyancy and positive stability such that the following conditions are simultaneously satisfied:
- the metacentric height after symmetrical flooding is equal to or greater than 0,05 m;

- the final waterline is below the lower edge of any opening on the hull, superstructure or deckhouse through which progressive flooding could take place;
- the angle of heel of the vessel after flooding is less than 15°, or 17° if no part of the deck is immersed.

In addition, the dynamic stability is to be examined and will be deemed acceptable if the positive residual righting lever curve, with the dredging unit flooded, has a range of at least 20° beyond the angle of equilibrium and a righting lever within this range of at least 0,1 m.

## 2 Structure design principles

### 2.1 General

**2.1.1** The attention of Designers is drawn to the fact that structural arrangement of ships for dredging activities involves discontinuities and that particular care is to be taken to avoid cracks or fractures.

**2.1.2** Where dredgers are likely to work in association with hopper barges, the sheerstrake is to be protected, slightly below the deck, by a fender efficiently secured to the shell plating and extending over at least two thirds of the ship's length. Compensation is to be provided in way of the gangway port in raised deck, if fitted.

**2.1.3** Where dredgers are likely to work in association with hopper barges, the shell plating is to be protected by a fender extending from the load waterline to the lowest waterline.

Additional structural reinforcements are to be provided in way of fenders and submitted to the Society for approval.

**2.1.4** On bucket dredgers, in order to prevent dangerous flooding in the event of damage to the shell plating by metal debris (e.g. anchors), a watertight compartment is to be provided at the lower part of the caissons on either side of the bucket well in the area of the buckets. The compartment is to be of adequate size to allow surveys to be carried out.

**2.1.5** Reinforcements are to be provided at locations where the hull is heavily stressed, such as:

- beneath the suction pipe gallows
- in way of the gallow frame on bucket dredgers
- points where tow ropes are secured
- connections of piles, etc.

**2.1.6** The strengthening of the flat bottom at ends is to be examined by the Society on a case-by-case basis.

**2.1.7** Weirs are to be provided in the hopper spaces. Their sectional area is to be large enough, taking into account the density of the water-spoil mixture to be drained off.

The disposition and location of the weirs are to be such that:

- they prevent the maximum authorised draught from being exceeded during loading
- trim and stability are always in accordance with the reviewed loading conditions
- draining off is made without any overflowing on the decks.

**2.1.8** In trailing suction hoppers, where (B+D) is greater than 21 m, a double bottom is to be provided between the collision bulkhead and the fore bulkhead of the closest hopper space. The double bottom may, however, be interrupted in way of the dredging pump.

**2.1.9** The corners of the cut-outs in the bottom plating are to be rounded and the radius is to be as large as possible, especially near the bottom doors.

The shape and the radius of cut-out corners are to be in accordance with Pt B, Ch 4, Sec 6.

**2.1.10** Where hopper barges and suction dredgers are intended for deep sea navigation, it is recommended, as far as possible, that sidescuttles should not be fitted in the shell plating.

**2.1.11** The brackets are generally to be of a swept shape. A flange is to be fitted on the free edge if the length of this edge exceeds 60 times the web thickness.

**2.1.12** For ships with either of the service notations **split hopper dredger** and **split hopper unit**, where panting beams are provided as stated in Pt B, Ch 9, Sec 1, [2.7], stringers and web frames are to be fitted on the centreline bulkheads of the two half-hulls to take up the reactions.

### 2.2 Longitudinal members in the area of the hopper well

**2.2.1** The scantlings of the midship region are generally to be kept over the full length of the hopper well.

**2.2.2** Attention is to be paid to the structural continuity of longitudinal members, especially coaming and hopper well bulkheads.

**2.2.3** The upper deck stringer plate is to extend to the longitudinal bulkhead over the full length of the hopper well.

**2.2.4** The fore and aft ends of the longitudinal bulkheads of the hopper spaces are to be extended by large brackets generally having a length and a width equal to D/4. It is recommended that a swept shape should be provided for these brackets (see Fig 2).

The upper bracket is to be welded to the deck and extended by a longitudinal deck girder.

**Figure 2 : Brackets at fore and aft ends of longitudinal bulkheads of the hopper spaces**

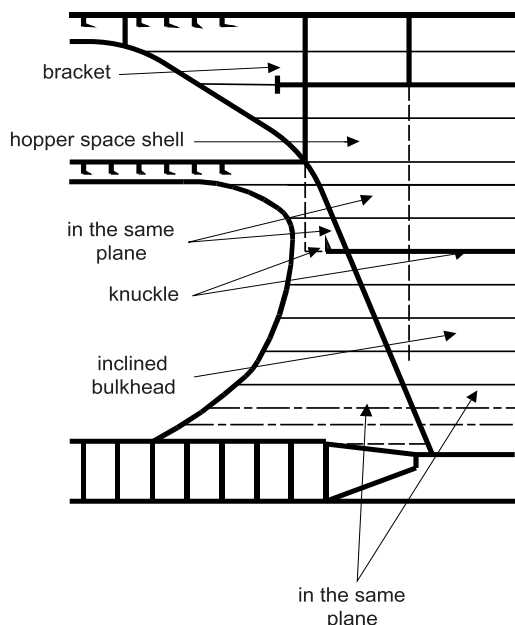

The lower bracket, which is generally oblique, is to be welded to the bottom or to the tank top. In the latter case, the lower bracket is to be extended inside the double bottom by means of a solid keelson extending at least over three frame spaces beyond the end of the bracket.

**2.2.5** The fore and aft ends of the centreline cellular keel are to be extended by means of brackets having a length at least equal to the depth of this keel.

In areas where a double bottom is provided, the brackets may be arranged in accordance with Fig 3.

**Figure 3 : Brackets at fore and aft ends of cellular keel**

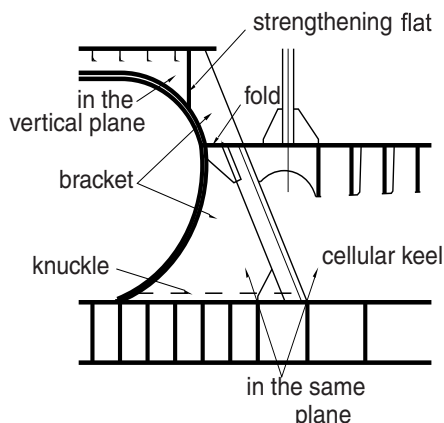

**2.2.6** The vertical sides of the trunks are to be extended beyond the end of the hopper spaces over a distance of at least 1,5 times their height.

**2.2.7** The Society may, on a case-by-case basis, require that longitudinal members of the double bottom structure are extended, by means of brackets, inside the side compartments bounding the hopper spaces.

**2.2.8** Arrangements other than those described in [2.2.4] to [2.2.7] are to be considered by the Society on a case-by-case basis.

### 2.3 Transverse members in the area of the hopper well

#### 2.3.1 Transverse primary supporting rings

Within the hopper well area, transverse primary supporting rings are to be provided and are to involve:

- deep floors inside hopper spaces
- side vertical primary supporting members
- hopper well vertical primary supporting members
- strong beams inside hopper spaces, at deck or trunk level
- where necessary, cross-ties connecting either the side vertical primary supporting members to the hopper well vertical primary supporting members or the floor to the hopper well vertical primary supporting members.

The spacing of the transverse rings is generally to be taken not greater than five frame spaces.

**2.3.2** The cellular keel is to be rigidly connected to the transverse rings required in [2.3.1].

**2.3.3** The upper part of the cellular keel may be connected to the deck or trunk structure by means of axial or inclined pillars in association with strong beams, or by a centreline wash bulkhead.

**2.3.4** The connection of hopper space floors with the longitudinal bulkheads and the cellular keel is to be arranged such that the continuity of the strength is ensured.

Where the floor is made of a box with sloping sides, particular attention is to be paid to the continuity of the lower flange. Fig 4 shows an example of possible connection.

**2.3.5** The connection between the flanges of the strong beams and the adjacent structure is generally to be made by means of brackets having the thickness of these flanges and extending inside the adjacent structure.



**Figure 4 : Example of connection with floor made of box with sloping sides**

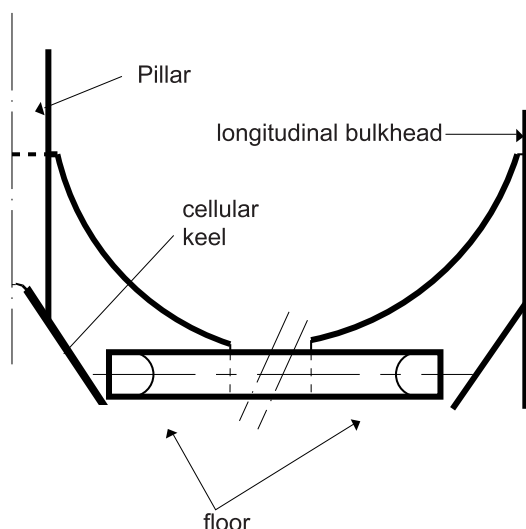

## 2.4 Arrangements relating to suction pipes

**2.4.1** Where a cut-out is necessary in the side shell plating to fit the suction pipe guides, continuity of members is to be restored, for example by means of knuckled plates as thick as the side shell plating and with a knuckle angle as small as possible.

The knuckles are to be stiffened by reinforced vertical primary supporting members and intercostal girders of the same web height (see Fig 5 and Fig 6).

The fillet welding between the web of vertical primary supporting members and the knuckled plates is not to be made onto the knuckles, but about 50 mm apart.

**Figure 5 : Transversely framed side - Cut-out reinforced by means of knuckled plate**

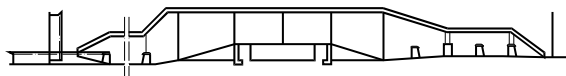

**Figure 6 : Longitudinally framed side - Cut-out reinforced by means of knuckled plate**

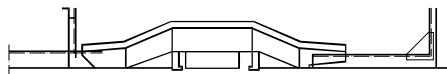

**2.4.2** The suction pipe guides are to be fitted as far as possible from the hopper space ends or from any cut-out in the bottom or deck plating.

A 60% reinforced deck plate, not exceeding 38 mm, is to be provided in way of the cut-out of the guides. This plate is to extend over at least one frame space forward and aft of the vertical primary supporting members provided for in [2.4.1].

**2.4.3** In areas where, during suction pipe operations, the drag head and the joint may run against the hull, one or several of the following arrangements are generally to be provided:

- thickness plating in excess of thickness obtained according to Pt B, Ch 7, Sec 1 or Pt B, Ch 8, Sec 3, as applicable, for bilge and side shell
- reinforcement of the structure by means of vertical primary supporting members, girders, intermediate frames or longitudinals, depending on the construction type
- fenders to be provided outside the hull; these fenders together with the bilge shape are not to impede the suction pipe operation
- cofferdam to be provided to limit the possible flooding of side compartments.

**2.4.4** The suction pipes are generally to be fitted with:

- auxiliary devices able to lift the suction pipe, in addition to the suction pipe davits
- a sufficient number of attachment points on the suction pipe itself, to facilitate handling
- a load limiting device to avoid any overload, if the suction pipe is equipped with cutting teeth
- accessories fitted onto the suction pipe built in several parts to facilitate partial replacements in case of damage.

## 2.5 Chafing areas

**2.5.1** Some parts of the structure subjected to heavy wear, such as longitudinal bulkheads of hopper spaces, may be protected or reinforced to avoid frequent replacement.

**2.5.2** If protection is provided by means of removable plates, called chafing plates, attention is to be paid to avoid corrosion between the facing sides of these plates and the hopper space plating.

**2.5.3** If reinforcement is made by increasing the thickness, the section moduli may be determined taking into account the extra thickness, provided that the chafing limits, beyond which the plates are to be replaced, are determined according to the extra thickness values.

If this extra thickness is disregarded in the section moduli calculation, this is to be clearly indicated on the midship section drawing.

## 2.6 Reinforcements for grounding

**2.6.1** If grounding is considered for normal operation of the ship, the bottom plating and the bottom structure are to be reinforced as indicated in [2.6.2] to [2.6.5].

**2.6.2** Along the full length of the ship, in the area of flat bottoms, the bottom net thickness obtained according to Pt B, Ch 7, Sec 1 or Pt B, Ch 8, Sec 3, as applicable, is to be increased by 2,5 mm.

**2.6.3** Where the ship has a transversely framed double bottom, floors are to be fitted at each frame space and associated with intercostal longitudinal girders, the mean spacing of which is to be not greater than 2,10 m.

Moreover, intercostal longitudinal ordinary stiffeners located at mid-spacing of bottom girders are to be provided.

**2.6.4** Where the ship has a longitudinally framed double bottom, the floor spacing may not exceed three frame spaces and the bottom girder spacing may not exceed three longitudinal ordinary stiffener spaces.

Intercostal transverse stiffeners are to be provided at mid-span of longitudinal ordinary stiffeners.

Floors are to be stiffened by vertical stiffeners having the same spacing as the longitudinal ordinary stiffeners.

**2.6.5** Where the ship is built with open hopper spaces (bottom doors provided on the bottom), reinforcements as required in [2.6.3] or [2.6.4] are to be provided within the side compartments, the cellular keel and, in general, within the limits of the flat bottom area.

## 2.7 Bolted structures

**2.7.1** Where the dredger is made of several independent members connected by bolting, the connection is to be examined by the Society on a case-by-case basis.

## 3 Design loads

### 3.1 General

**3.1.1** Design loads are to be determined for the various load cases in the following two situations:

- navigation situation, considering the draught T
- dredging situation, considering the dredging draught  $T_D$ .

**3.1.2** For dredgers made of bolted structure, the Society may require the hull girder loads calculated with the maximum length of the unit when mounted to be applied to each individual element.

### 3.2 Still water hull girder loads

#### 3.2.1 Loading conditions

In addition to the requirements in Pt B, Ch 5, Sec 2, [2.1] or Pt B, Ch 8, Sec 1, [2.2], as applicable, still water loads are to be calculated for the following loading conditions:

- homogeneous loading at maximum dredging draught if higher than the maximum service draught
- partial loading conditions
- any specified non-homogeneous loading condition, in particular where dredgers are fitted with several hopper spaces
- navigation conditions with hopper space(s) filled with water up to the load line
- working conditions at international freeboard with the hopper space(s) filled with spoil
- ballast navigation conditions, with empty hopper space(s), if applicable.

Calculation of the still water bending moment and shear force for any loading case corresponding to a special use of the ship may be required by the Society on a case-by-case basis. In particular, in the case of stationary dredgers, the

curve of the still water bending moment, where the suction pipe is horizontal, is to be submitted to the Society.

#### 3.2.2 Vertical still water bending moments in dredging situation

In addition to the vertical still water bending moments  $M_{SW,H}$  and  $M_{SW,S}$  in navigation situation, defined in Pt B, Ch 5, Sec 2, [2.2] or Pt B, Ch 8, Sec 1, [2.2], as applicable, the vertical still water bending moments in dredging situation  $M_{SW,H,D}$  and  $M_{SW,S,D}$  are also to be considered, in hogging and sagging conditions, respectively.

If the design vertical still water bending moments in dredging situation are not defined at a preliminary design stage, at any hull transverse section, the longitudinal distributions shown in Pt B, Ch 5, Sec 2, Fig 4 may be considered, where  $M_{SW}$  is the vertical design still water bending moment amidships, in dredging hogging or sagging conditions, whose absolute values are to be taken not less than the values obtained, in kN.m, from the following formulae:

- in hogging conditions:

$$M_{SWM,H,D} = 175n_1CL^2B(C_B + 0,7)10^{-3} - M_{WV,H,D}$$

- in sagging conditions:

$$M_{SWM,S,D} = 175n_1CL^2B(C_B + 0,7)10^{-3} + M_{WV,S,D}$$

where  $M_{WV,H,D}$ ,  $M_{WV,S,D}$  are the vertical wave bending moments in dredging situation, in kN.m, defined in [3.3.1].

### 3.3 Wave hull girder loads

#### 3.3.1 Vertical wave bending moments in dredging situation

In addition to the vertical wave bending moments  $M_{WV,H}$  and  $M_{WV,S}$  in navigation situation, defined in Pt B, Ch 5, Sec 2, [3.1] or Pt B, Ch 8, Sec 1, [2.3], as applicable, the vertical wave bending moments in dredging situation at any hull transverse section are to be obtained, in kN.m, from the following formulae:

- in hogging conditions:

$$M_{WV,H,D} = 190F_M n_D CL^2 BC_B 10^{-3}$$

- in sagging conditions:

$$M_{WV,S,D} = -110F_M n_D CL^2 B(C_B + 0,7)10^{-3}$$

where:

$F_M$  : Distribution factor defined in Pt B, Ch 5, Sec 2, Tab 1 or Pt B, Ch 8, Sec 1, Tab 2, as applicable (see also Pt B, Ch 5, Sec 2, Fig 5 or Pt B, Ch 8, Sec 1, Fig 1, as applicable)

$n_D$  : Operating area coefficient defined in Tab 1 depending on  $H_s$ , without being taken greater than n

$H_s$  : Maximum significant wave height, in m, for operating area in dredging situation, according to the operating area notation assigned to the ship (see Pt A, Ch 1, Sec 2, [4.7.3]).

**Table 1 : Operating area coefficients in dredging situation**

$H_s$ , in m	Operating area coefficient $n_D$
$H_s < 2,5$	1/3
$2,5 \leq H_s < 4$	2/3
$H_s \geq 4$	1

### 3.4 Additional hull girder loads for split hopper dredgers and split hopper units

#### 3.4.1 Application

The provisions in [3.4.3] to [3.4.6] apply to ships with one of the service notations **split hopper dredger** and **split hopper unit**, in addition to the requirements in Part B, Chapter 5.

#### 3.4.2 General

Horizontal bending moments are to be calculated assuming that the hopper well is simply supported at each end.

The clearance between the two half-hulls is to be large enough not to be suppressed when the hopper well is full up.

Details of the calculation of the necessary clearances are to be submitted to the Society for review.

However, the calculation of the horizontal moments is carried out assuming that both ends of the hopper well are partly clamped, on condition that at deck and bottom level chocks are provided forward and aft of the well so that:

- the clearance between the two half-hulls is nil
- the chocks are long enough to withstand the end moments due to the horizontal forces developed along the hopper well.

#### 3.4.3 Horizontal still water bending moment

The horizontal still water bending moment to be applied on one half-hull, in navigation and dredging situations, is to be obtained, in kN.m, from the formulae given in Tab 2.

**Table 2 : Split hopper dredgers and split hopper units - Horizontal still water bending moment on half-hulls**

Condition of attachment of hopper well ends	Horizontal still water bending moment $M_{SHH}$ , in kN.m	
	Midship area	Hopper well ends
Partly clamped	$-\alpha_1 p \ell_p^2$	$\alpha_1 p \ell_p^2$
Simply supported	$-\left(\frac{1}{8} + \frac{c_1}{2L_p}\right) p \ell_p^2$	0

**Note 1:**  
 $\alpha_1$  : Coefficient defined in Tab 3, depending on  $c_1/\ell_p$   
 $p$  : Load per metre, in kN/m, applied along the hopper well, defined in Tab 4 depending on the loading condition  
 $c_1$  : Distance, in m, from deck hinges to ends of hopper well (see Fig 7).

**Table 3 : Coefficient  $\alpha_1$** 

$c_1/\ell_p$	$\alpha_1$
0,005	0,0850
0,010	0,0867
0,015	0,0884
0,020	0,0899
0,025	0,0916
0,030	0,0932
0,035	0,0948
0,040	0,0964
0,045	0,0980
0,050	0,0996
0,055	0,1013
0,060	0,1028

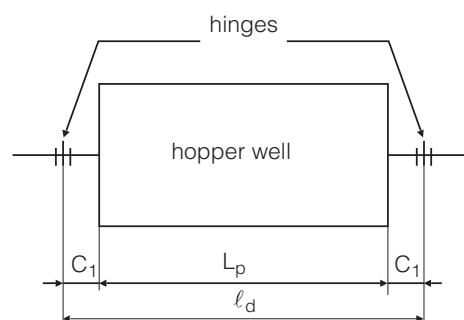
**Figure 7 : Definitions of dimensions in hopper well area**

**Table 4 : Load per metre applied along the hopper well**

Loading condition	p, in kN/m
Maximum loading at dredging draught	$\frac{\delta(h_1 - a)^2 - 1,025(T_D - a)^2}{2}g$
Loading corresponding to international freeboard with well full of spoil	$\frac{\delta(h_2 - a)^2 - 1,025(T - a)^2}{2}g$
Service condition with well filled with water up to the waterline	0
Service condition with well filled with water up to the highest weir level	$\frac{1,025[(h_4 - a)^2 - (T_4 - a)^2]}{2}g$

**Table 5 : Split hopper dredgers and split hopper units - Horizontal wave bending moment on half-hulls**

Condition of attachment of hopper well ends	Horizontal wave bending moment $M_{WHH}$ , in kN.m	
	Midship area	Hopper well ends
Partly clamped	$(\alpha_2 T + \alpha_3 F k_f) \frac{M_{WV}}{B}$	$-(\alpha_4 T + \alpha_5 F k_f) \frac{M_{WV}}{B}$
Simply supported	$(T + \alpha_6 F k_f) \frac{M_{WV}}{B}$	0

**Note 1:**  
 $\alpha_2, \alpha_3, \alpha_4, \alpha_5, \alpha_6$ : Coefficients defined in Tab 6, depending on  $\ell_D/L$   
T : Draught, in m, corresponding to the loading condition considered  
 $k_f$  : Coefficient taken equal to:  
 $k_f = 0,128 n_D (C_B + 0,7)$   
 $M_{WV}$  : Vertical wave bending moment, in kN.m, defined in:  

- Pt B, Ch 5, Sec 2, [3.1] for the navigation situation
- [3.3.1] for the dredging situation.

**Table 6 : Coefficients  $\alpha_2, \alpha_3, \alpha_4, \alpha_5, \alpha_6$** 

$\ell_D/L$	$\alpha_2$	$\alpha_3$	$\alpha_4$	$\alpha_5$	$\alpha_6$
0,25	0,050	0,037	0,097	0,046	-0,309
0,30	0,071	0,052	0,135	0,062	-0,247
0,35	0,095	0,070	0,178	0,080	-0,185
0,40	0,122	0,090	0,224	0,098	-0,123
0,45	0,151	0,111	0,271	0,116	-0,062
0,50	0,182	0,134	0,318	0,134	0
0,55	0,214	0,158	0,364	0,151	0,062
0,60	0,248	0,184	0,407	0,168	0,123
0,65	0,282	0,211	0,445	0,186	0,185
0,70	0,316	0,239	0,478	0,204	0,247
0,75	0,350	0,269	0,504	0,225	0,309
0,80	0,383	0,300	0,521	0,247	0,370

**3.4.4 Horizontal wave bending moment**

The horizontal wave bending moment to be applied on one half-hull, in navigation and dredging situations, is to be obtained, in kN.m, from the formulae given in Tab 5.

**3.4.5 Combined still water and wave vertical bending moment**

In the midship area, the total vertical bending moment  $M_V$  to be applied on half-hull is to be obtained, in kN.m, from Tab 7.

At hopper well ends, the total bending moment  $M_V$  is to be determined in accordance with Tab 7 considering:

- for the still water vertical bending moment: the greater of the values at the fore and aft hopper well ends
- for the vertical wave bending moment: the longitudinal distribution defined in Pt B, Ch 5, Sec 2, Tab 1 or Pt B, Ch 8, Sec 1, Tab 2, as applicable.

**Figure 8 : Definitions of distances for calculation of the load applied along the hopper well**

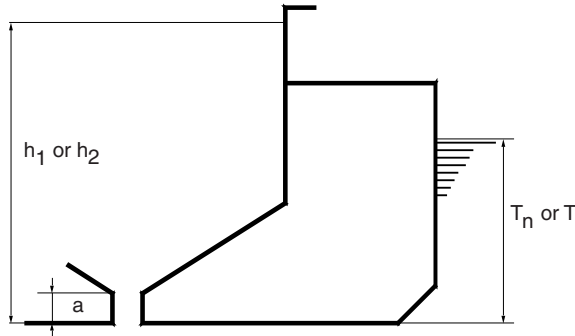

### 3.4.6 Combined still water and wave horizontal bending moment

The total horizontal bending moment  $M_H$  applied on half-hull, in midship area and at hopper well ends, is to be obtained, in kN.m, from the following formulae:

- in navigation situation:  $M_H = M_{SHH} + n M_{WHH}$
- in dredging situation:  $M_H = M_{SHH} + n_D M_{WHH}$

where:

$M_{SHH}$  : Horizontal still water bending moment, defined in [3.4.3] in midship area and at hopper well ends

$M_{WHH}$  : Horizontal wave bending moment, defined in [3.4.4] in midship area and at hopper well ends.

## 3.5 Internal pressures for hopper well in dredging situation

### 3.5.1 Still water pressure for hopper well

The still water pressure to be used in connection with the inertial pressure in [3.5.2] is to be obtained, in kN/m<sup>2</sup>, from the following formula:

$$p_s = 0,9\delta_1 d_D$$

where:

**Table 7 : Vertical bending moment applied on half-hull**

Condition	Vertical bending moment $M_v$ , in kN.m	
	Navigation situation	Dredging situation
Hogging	$\frac{M_{SW,H} + M_{WV,H}}{2}$	$\frac{M_{SW,H,D} + M_{WV,H,D}}{2}$
Sagging	$\frac{M_{SW,S} + M_{WV,S}}{2}$	$\frac{M_{SW,S,D} + M_{WV,S,D}}{2}$

**Note 1:**  
 $M_{SW,H}$ ,  $M_{SW,S}$ : Still water vertical bending moment in navigation situation in hogging and sagging condition, respectively, defined in Pt B, Ch 5, Sec 2, [2.2] or Pt B, Ch 8, Sec 1, [2.2], as applicable  
 $M_{WV,H}$ ,  $M_{WV,S}$ : Wave vertical bending moment in navigation situation in hogging and sagging condition, respectively, defined in Pt B, Ch 5, Sec 2, [3.1] or Pt B, Ch 8, Sec 1, [2.3], as applicable  
 $M_{SW,H,D}$ ,  $M_{SW,S,D}$ : Still water vertical bending moment in dredging situation, in hogging and sagging condition, respectively, defined in [3.2.2]  
 $M_{WV,H,D}$ ,  $M_{WV,S,D}$ : Wave vertical bending moment in dredging situation, in hogging and sagging condition, respectively, defined in [3.3.1].

$\delta_1$  : Coefficient equal to:

$$\delta_1 = \delta \quad \text{for } \delta < 1,35$$

$$\delta_1 = \delta + (1,35 - \delta)(\sin \alpha)^2 \quad \text{for } \delta \geq 1,35$$

$d_D$  : Vertical distance, in m, from the calculation point to the highest weir level with the corresponding specific gravity of the mixture of sea water and spoil

$\alpha$ : Angle, in degrees, between the horizontal plane and the surface of the hull structure to which the calculation point belongs.

### 3.5.2 Inertial pressure for hopper well

The inertial pressure is to be obtained from Tab 8.

## 4 Hull girder strength

### 4.1 General

4.1.1 The hull girder strength of:

- ships with one of the service notations **dredger, hopper dredger and hopper unit**
- ships with either of the service notations **split hopper dredger** or **split hopper unit**, considered with the two half-hulls connected,

is to be checked for navigation situation and dredging situation according to the criteria of Part B, Chapter 6 or Pt B, Ch 8, Sec 2, as applicable.

4.1.2 In addition, the hull girder strength of each half-hull of ships with either of the service notations **split hopper**

dredger or split hopper unit is to be checked according to the criteria of [5].

**Table 8 : Ships for dredging activities - Inertial pressure for hopper well**

Ship condition	Load case	Inertial pressure $p_w$ , in kN/m <sup>2</sup>
Upright condition	"a"	No inertial pressure
	"b"	$0,9\delta_1 a_{z1} d_D$
Inclined condition	"c"	$0,45\delta_1 a_{z2} d_D$
	"d"	$0,63\delta_1 a_{z2} d_D$

**Note 1:** The accelerations  $a_{z1}$  and  $a_{z2}$  are to be determined according to Pt B, Ch 5, Sec 3, [3.4], considering the ship in dredging situation, i.e. considering the draught equal to the dredging draught  $T_D$ .

**4.1.3** For dredgers made of bolted structure, the Society may require the hull girder strength criteria to be applied to each individual element, considering the loads calculated according to [3.1.2].

## 4.2 Section modulus

**4.2.1** In the determination of the hull midship section modulus according to Pt B, Ch 6, Sec 1, [2.3] or Pt B, Ch 8, Sec 2, [1.3], as applicable, account is to be taken of:

- 85 % of the sectional area of the cellular keel
- 60 % of the sectional area of deck girders in way of the hopper spaces
- 60 % of the centreline wash plate, provided that its connection to the deck has a length equal to at least 1,5 times its depth.

**4.2.2** Where cut-outs in the side shell are needed to fit the suction pipe guides, a section modulus calculation not taking account of the side shell plating may be required by the Society on a case-by-case basis, if the structural continuity is not correctly achieved.

## 5 Additional requirements for hull girder strength of split hopper dredgers and split hopper units

### 5.1 General

**5.1.1** For ships with either of the service notations **split hopper dredger** or **split hopper unit**, the yielding check of each half-hull is to be carried out according to [5.1] to [5.4] considering:

- each half-hull as being subjected to independent bending
- the deck hinges and the hydraulic jacks acting as supports at the ends of the hopper well.

**5.1.2** Both the vertical bending moment and horizontal bending moment acting within the well area are to be taken into account.

## 5.2 Definitions

### 5.2.1 Co-ordinate system

The hull girder strength is defined with reference to the following co-ordinate system, as shown in Fig 9:

G : Centre of gravity of the transverse section

GY : Transverse axis, parallel to Y defined in Pt B, Ch 1, Sec 2, [4] and crossing through G

GZ : Vertical axis, parallel to Z defined in Pt B, Ch 1, Sec 2, [4] and crossing through G

Gy, Gz : Main axes of the transverse section, defined in [5.2.2].

**Figure 9 : Half-hull co-ordinate system**

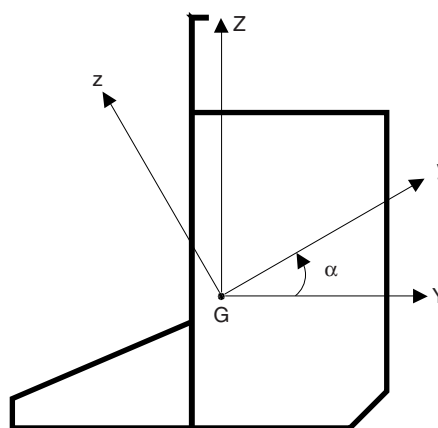

### 5.2.2 Main axes

The main axes Gy and Gz are obtained from the axes GY and GZ by a rotation around the centre of gravity G of an angle  $\alpha$  obtained from the following formula:

$$\alpha = \frac{1}{2} \operatorname{atan} \left( \frac{2I_{YZ}}{I_Z - I_Y} \right)$$

where:

$I_Y$  : Moment of inertia, in m<sup>4</sup>, of the transverse section around the axis GY

$I_Z$  : Moment of inertia, in m<sup>4</sup>, of the transverse section around the axis GZ

$I_{YZ}$  : Inertia product, in m<sup>4</sup>, of the transverse section, in the reference (G, GY, GZ).

### 5.2.3 Bending moments

The bending moments  $M_y$  and  $M_z$  in relation to the main axes Gy and Gz, respectively, are to be obtained, in kN.m, from the following formulae:

$$M_y = M_V \cos \alpha + M_H \sin \alpha$$

$$M_z = -M_V \sin \alpha + M_H \cos \alpha$$

where:

$M_V$  : Vertical bending moment defined in [3.4.5], in kN.m, to be considered in hogging and sagging conditions, for the navigation and dredging situations

$M_H$  : Horizontal bending moment defined in [3.4.6], in kN.m, to be considered in hogging and sagging conditions, for the navigation and dredging situations

$\alpha$  : Angle defined in [5.2.2].

As the main inertia axes of each half-hull are oblique, the bending of each half-hull is a deviated bending.

### 5.3 Hull girder stress

**5.3.1** At any point of the transverse section of each half-hull, the hull girder normal stresses are to be obtained, in N/mm<sup>2</sup>, from the following formula:

$$\sigma_{x1} = \left( z \frac{M_y}{I_{yM}} - y \frac{M_z}{I_{zM}} \right) 10^{-3}$$

where:

$M_y, M_z$  : Bending moments, in kN.m, in hogging and sagging conditions, for the navigation and dredging situations, defined in [5.2.3]

$I_{yM}, I_{zM}$  : Moments of inertia, in m<sup>4</sup>, of the transverse section around its main axes

$y, z$  :  $y$  and  $z$  coordinates, in m, of the calculation point with respect to the main axes  $G_y$  and  $G_z$ .

**5.3.2** In the case of partly clamped ends of the hopper well (see [3.4.2]), the hull girder normal stresses are to be calculated in the midship area and at hopper well ends.

In this case, the stresses are also to be calculated in the midship area assuming the ends supported as regards the horizontal moment. This calculation relates to the beginning of the hopper well drainage by opening of the two half-hulls.

**5.3.3** In the case of supports at hopper well ends, the calculation of the hull girder normal stress is to be carried out in the midship area.

**5.3.4** For each section of calculation, the most unfavourable combination of moments is to be considered.

### 5.4 Checking criteria

**5.4.1** It is to be checked that the normal stresses calculated according to [5.3.1] are in compliance with the following formula:

$$\sigma_1 \leq \sigma_{1,ALL}$$

where:

$\sigma_{1,ALL}$  : Allowable normal stress:

$$\sigma_{1,ALL} = 200/k \text{ N/mm}^2$$

## 6 Hull scantlings

### 6.1 General

**6.1.1** Hull scantlings are to be checked according to the applicable requirements of Part B, Chapter 7 or Part B, Chapter 8, as applicable, for the following two situations:

- navigation situation, considering the draught  $T$
- dredging situation, considering the dredging draught  $T_D$ .

### 6.2 Minimum net thicknesses of plating

**6.2.1** The net thickness of plating is to be not less than the greater of the following values:

- 5 mm
- thickness, in mm, obtained from Tab 9.

**Table 9 : Ships for dredging activities - Minimum net thicknesses of plating**

Plating	Minimum net thickness, in mm
Keel	$5,1 + 0,040 L k^{1/2} + 4,5 s$
Bottom	<ul style="list-style-type: none"> <li>• transverse framing <math>4,3 + 0,036 L k^{1/2} + 4,5 s</math></li> <li>• longitudinal framing <math>3,4 + 0,036 L k^{1/2} + 4,5 s</math></li> </ul>
Inner bottom outside hopper spaces	$2,0 + 0,025 L k^{1/2} + 4,5 s$
Side	<ul style="list-style-type: none"> <li>• below freeboard deck <math>2,5 + 0,031 L k^{1/2} + 4,5 s</math></li> <li>• between freeboard deck and strength deck <math>2,5 + 0,013 L k^{1/2} + 4,5 s</math></li> </ul>
Strength deck within 0,4L amid-ships	<ul style="list-style-type: none"> <li>• transverse framing <math>2,5 + 0,040 L k^{1/2} + 4,5 s</math></li> <li>• longitudinal framing <math>2,5 + 0,032 L k^{1/2} + 4,5 s</math></li> </ul>
Hopper well	<ul style="list-style-type: none"> <li>• transverse and longitudinal bulkheads <math>2,7 + 0,034 L k^{1/2} + 4,5 s</math></li> <li>• cellular keel plating <math>2,7 + 0,034 L k^{1/2} + 4,5 s</math></li> </ul>

**6.2.2** When no protection is fitted on the deck areas where heavy items of dredging equipment may be stored for maintenance, the net thickness of the deck plating is to be not less than the value obtained, in mm, from the following formula:

$$t = 5,1 + 0,040 L k^{1/2} + 4,5 s$$

### 6.3 Bottom plating

**6.3.1** Where the bottom is longitudinally framed and the bilge is made of a transversely framed sloped plate, the bottom is to be assumed as being transversely framed when calculating the plating thickness.

**6.3.2** The net thickness of the bottom strake, to which the longitudinal bulkheads of the hopper space are connected, is to be not less than the greater of the following thicknesses:

- bottom plating thickness increased by 15%
- keel thickness.

### 6.4 Well bulkhead and cellular keel platings

**6.4.1** The net thickness of hopper well bulkhead plating and cellular keel plating is to be not less than the net thickness obtained:

- in dredging situation, considering the internal pressures defined in [3.5].

- in navigation situation, where the hopper well bulkheads limit tank compartments, considering the internal pressures defined in Pt B, Ch 5, Sec 6, [1] or Pt B, Ch 8, Sec 1, [5], as applicable.

**6.4.2** The net thickness of the longitudinal bulkhead above the deck or within 0,1D below the deck is to be not less than the net thickness of the strength deck abreast of the hatchways.

**6.4.3** The net thickness of the transverse and longitudinal bulkhead of a dredgepipe well is to be determined as for the side shell net thickness.

## 6.5 Transversely framed bottoms

### 6.5.1 Floors

The scantlings of floors located inside large compartments, such as pump rooms, are to be obtained from a direct calculation, according to Pt B, Ch 7, App 1 as applicable, and taking into account the following assumptions:

- floors are simply supported at ends
- local discontinuities in strength, due to the presence of wells, are to be considered.

## 6.6 Buckling check of plating and ordinary stiffeners for split hopper dredgers and split hopper units

### 6.6.1 Buckling

For ships with either of the service notations **split hopper dredger** or **split hopper unit**, the buckling check of plating and ordinary stiffeners subjected to compression stresses is to be carried out according to Pt B, Ch 7, Sec 1, [5], Pt B, Ch 8, Sec 3, [5], Pt B, Ch 7, Sec 2, [4] or Pt B, Ch 8, Sec 4, [4], as applicable, considering the maximum compression stresses calculated according to [5.3], in hogging and sagging conditions, for the navigation and dredging situations.

## 7 Hopper dredgers and hopper units: checking of hopper well structure

### 7.1 General

**7.1.1** The requirements in [7.1] to [7.5] apply to ships with either of the service notations **hopper dredger** or **hopper unit**.

**7.1.2** At the ends of the hopper spaces, the transverse bulkheads are to extend over the full breadth of the ship. Where this is not the case, web rings with special scantlings are to be provided.

### 7.2 Floors

**7.2.1** The scantlings of floors of ships with open wells fitted with bottom doors are to be obtained from a direct calculation, according to Pt B, Ch 7, App 1 as applicable, and taking into account the following assumptions:

- the span is equal to half the sum of the upper face plate length and the distance between lower ends of the hopper well sloped bulkheads
- the floors have fixed ends
- the floors are subject to the uniform and concentrated loads detailed in [7.2.3]
- the central box (cellular keel) is supported by the floors. However, where this box has sufficient dimensions and scantlings to support a part of the loads, this may be taken into account if a relevant calculation of grid type is submitted to the Society.
- In addition to the loads laid down in [7.2.3], the floor may support differential loads, for example when all the valves are not simultaneously opened, or compression loads when the well is empty
- the web cut-out section is deducted for the calculations of shear stresses and normal stresses (tension or compression)
- for the calculation of normal stresses and bending stresses, the face plate cross-section is taken into account only if these face plates are correctly offset on the adjacent structure.

**7.2.2** The different types of bottom doors and valves generally used, as well as the relevant symbols, are defined in Fig 10 to Fig 14.

**Figure 10 : Bottom valve, centrally operated by a vertical shaft (Type 1)**

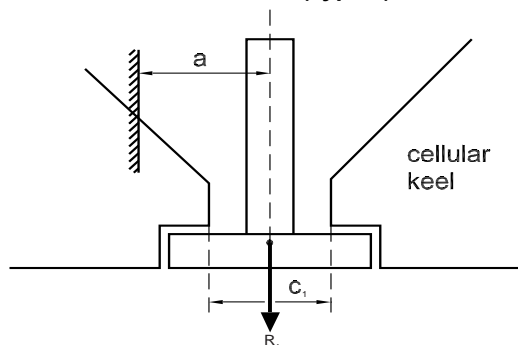

**7.2.3** The loads borne by floors are a combination, according to the type of bottom doors, of the elementary loads [a], [b], [c], [d], [e] and [f], obtained, in kN, from the following formulae:

[a] : Uniform load of spoils, to be taken equal to:

$$Q_1 = g\delta(D + h_D)S_a\ell$$

[b] : External hydrostatic pressure, to be taken equal to:

$$Q_2 = g(T_D - 0,5h_0)S_a\ell$$

In the course of calculations,  $P_r$  is the reduced pressure, evenly distributed, to be taken equal to:

$$P_r = \delta(D + h_D) - (T_D - 0,5h_0)$$

The resultant load is to be taken equal to:

$$Q = Q_1 - Q_2 = gP_rS_a\ell$$



[c] : Load acting directly on a valve (to be deducted), to be taken equal to:

$$q = gP_r A_{bd}$$

This load is assumed to be evenly distributed along the length  $c_1$ . It is to be cut off from the load  $Q$ .

In the case of type 5 bottom doors (see Fig 14),  $q = 0$

**Figure 11 : Single bottom door, with hinges at one side (either cellular keel side or lower wing tank side) and operated by a vertical shaft at the other side (Type 2)**

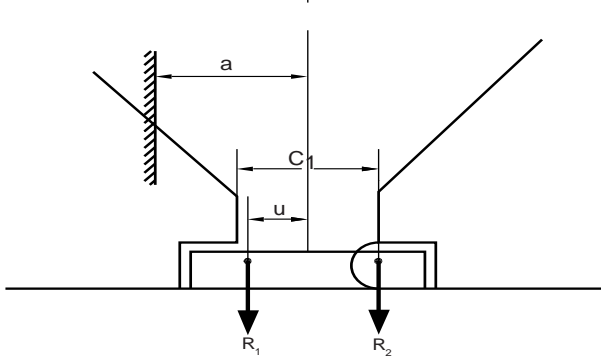

**Figure 12 : Double bottom doors, with hinges at both sides and operated by one central vertical shaft connected to the doors by means of two rods (Type 3)**

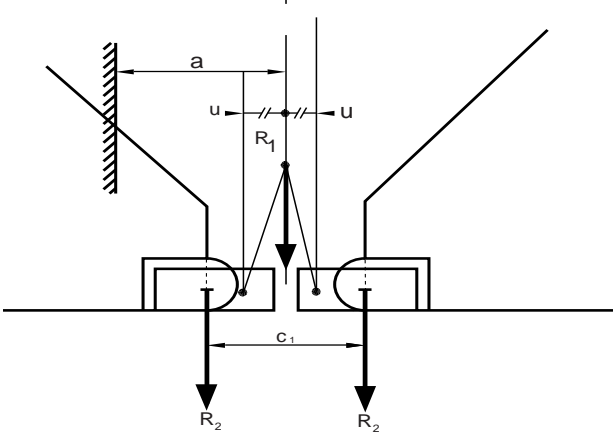

**Figure 13 : Longitudinal sliding bottom doors (Type 4)**

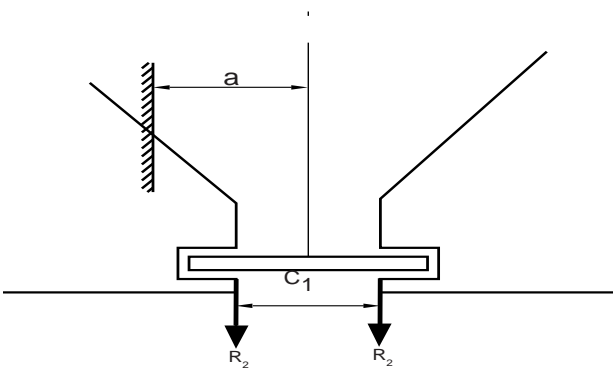

**Figure 14 : Transverse sliding bottom doors, guides being supported by floors (Type 5)**

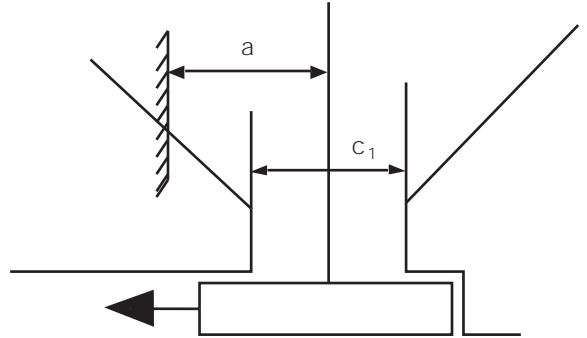

[d] : Reactions  $R_2$  of the bottom doors on the floor (to be added), the absolute values and abscissae of which are indicated in Tab 10.

Reactions  $R_1$  on the rods of the hydraulic jacks of bottom doors type 1 (see Fig 10), type 2 (see Fig 11) and type 3 (see Fig 12) are given in Tab 10 for further calculations but they are not borne by the floors.

[e] : Axial force due to the lack of spoils in the volume occupied by the cellular keel (to be deducted), to be taken equal to:

$$F_1 = g\delta S_a A$$

[f] : Axial force due to a possible transmission of the resultant reaction  $R_1$  to the cellular keel, through a strong beam, an axial pillar or inclined pillars, to be taken equal to:

- with one axial pillar:

$$F_2 = 4 \frac{vR_1}{\ell_0}$$

- with two inclined pillars:

$$F_2 = 2R_1$$

For determination of the scantlings of strong beams, girders and pillars,  $R_1$  is to be replaced by  $F_M$ , in kN, when calculating  $F_2$ , if  $F_M$  is higher than  $R_1$ ,  $F_M$  being the maximum force induced by the bottom door hydraulic jack.

where:

$h_D$  : Distance, in m, from the highest weir level, corresponding to the draught  $T_D$ , to the deck-line ( $h_D$  is to be counted negatively where the level is located below the deck-line at side)

$S_a$  : Transverse primary supporting ring spacing, in m

$\ell$  : Stiffener span, in m.

In the case of floors, the span is equal to half the sum of the length of the upper flange plate and the distance between the lower ends of the sloping sides of the hopper space.

$h_0$  : Ship relative motion, in m, defined in Pt B, Ch 5, Sec 3, [3.3] or Pt B, Ch 8, Sec 1, [3.3], as applicable

$A_{bd}$  : Whole sectional area, in  $m^2$ , of the bottom door whatever its type may be  
 $A$  : Area, in  $m^2$ , enclosed by the contour of the cellular keel

$v$  : Distance, in m, from the hydraulic jack centreline to the end of the strong beam span  
 $l_0$  : Span, in m, of the strong beam bearing the reactions of the hydraulic jacks.

**Table 10 : Reactions  $R_1$  and  $R_2$  for elementary load [d]**

Bottom door type (see Fig 10 to Fig 14)	Reactions $R_2$			Reactions $R_1$
	No.	Value, in kN	Abscissae	Value, in kN
1		0		$gA_{bd}P_r$
2	1	$gA_{bd}P_r\left(\frac{2u}{c_1+2u}\right)$	$(a + 0,5 c_1)$ or $(a - 0,5 c_1)$	$gA_{bd}P_r\left(\frac{c_1}{c_1+2u}\right)$
3	2	$0,25gA_{bd}P_r\left(\frac{c_1-4u}{c_1-2u}\right)$	$(a + 0,5 c_1)$ and $(a - 0,5 c_1)$	$0,5gA_{bd}P_r\left(\frac{c_1}{c_1-2u}\right)$
4	2	$0,5gA_{bd}P_r$	$(a + 0,5 c_1)$ and $(a - 0,5 c_1)$	0
5		0		0

**Note 1:**

$a$  : Distance, in m, from either end of the floor span to the centreline of the bottom door closest to that end  
 $c_1$  : Width of a bottom door, in m  
 $u$  : Distance, in m, from the fixing point of the hydraulic jack rod (or of the two rod hydraulic jack) to the centreline of the bottom door.

**7.2.4** The shear force diagrams corresponding to each elementary load defined in [7.2.3] are given in Fig 15 to Fig 20.

The total shear force, at abscissa X, equal to the algebraical sum of the elementary shear forces corresponding to each type of bottom doors, is indicated in Tab 11.

**7.2.5** The bending moments for each elementary load defined in [7.2.3] are given in Tab 12, at span ends and at mid-span.

**7.2.6** The resultant bending moment is the sum of the elementary moments for each type of valve.

The total moment value at abscissa X is determined by deducting algebraically from the total moment value at the span ends the value of the area bounded by the total shear force curve.

**Figure 15 : Shear force diagram for elementary load [a] - Load  $Q_1$**

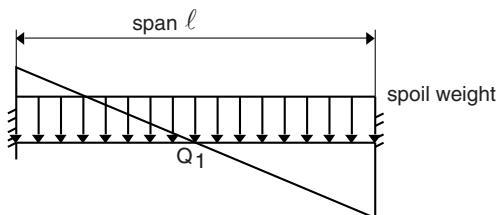

**Figure 16 : Shear force diagram for elementary load [b] - Load  $Q_2$**

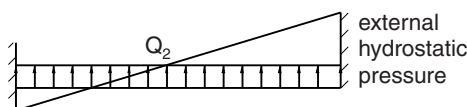

**Figure 17 : Shear force diagram for elementary load [c] - Load q**

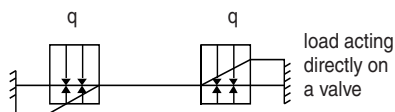

**Figure 18 : Shear force diagram for elementary load [d] - Reactions R<sub>2</sub>**

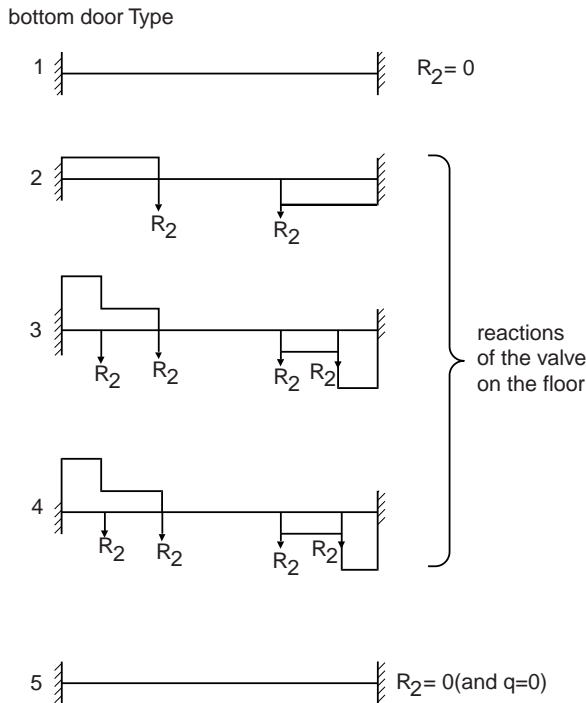

**Figure 19 : Shear force diagram for elementary load [e] - Force F<sub>1</sub>**

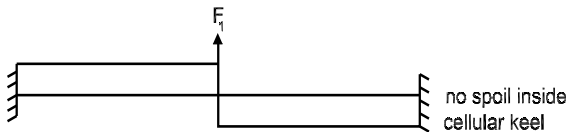

**Figure 20 : Shear force diagram for elementary load [f] - Force F<sub>2</sub>**

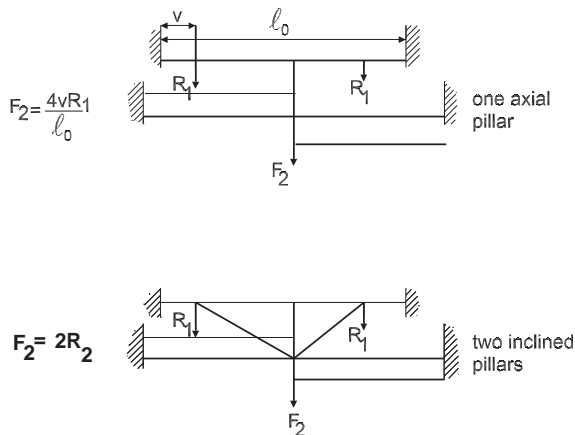

**Table 11 : Shear force values**

Bottom door type (see Fig 10 to Fig 14)	Total shear force T(x) at abscissa X, in kN
1	T <sub>0</sub>
2	T <sub>0</sub> + R <sub>2</sub>
3	T <sub>0</sub> + 2R <sub>2</sub>
4	T <sub>0</sub> + 2R <sub>2</sub>
5	T <sub>0</sub> + q - 0,5F <sub>2</sub>

**Note 1:**  
 X : Distance, in m, from the cross-section under consideration to the end of the floor span  
 T<sub>0</sub> : Total shear force, in kN, at the left end of the span, to be taken equal to:  

$$T_0 = \frac{1}{2}(Q_1 - Q_2 - 2q - F_1 + F_2)$$

**7.2.7** The normal load is to be obtained, in kN, from the following formula:

$$F_N = F_{N1} - F_{N2}$$

where:

$$F_{N1} = \frac{3,3S_a\delta}{2D - h_v}(D + h_D)^2(2D - h_D)$$

$$F_{N2} = \frac{3,3S_a}{2D - h_v}(T_D - 0,5h_0)^2(3D - T_D + 0,5h_0)$$

h<sub>v</sub> : Mean floor depth, in m.

**7.2.8** In the case of a differential opening of the valves, the stresses induced by the bending moments and the shear forces are determined as follows:

- the upper flange is assumed to be simply supported at ends; its span ℓ<sub>s</sub> is measured between the longitudinal bulkhead and the cellular keel
- the lower flange is assumed to have fixed ends and its span is taken equal to c<sub>1</sub>
- the transverse section moduli of the flanges are determined with respect to a vertical axis located in the plane of the floor web
- for the upper flange, the transverse bending moment at mid-span is obtained, in kN.m, from the following formula:

$$M_s = 0,05\delta h_v^2[3\ell_s^2 - (\ell_s - c_1)^2]$$

- for the upper flange, the maximum shear force at ends of span ℓ<sub>s</sub> is obtained, in kN.m, from the following formula:

$$T_s = 0,3\delta h_v^2(\ell_s + c_1)$$

- for the lower flange, the maximum bending moment and shear force, in kN at span ends are obtained, in kN.m, from the following formulae:

$$M_i = 1,33\left(\frac{c_1}{\ell_s}\right)^2 M_s$$

$$T_i = 2\left(\frac{c_1}{\ell_s}\right) T_s$$

Table 12 : Values of bending moments

Elementary load	Bending moment, in kN.m, at span ends	Bending moment, in kN.m, at mid-span
[a]	$-\frac{Q_1 \ell}{12}$	$\frac{Q_1 \ell}{24}$
[b]	$\frac{Q_2 \ell}{12}$	$-\frac{Q_2 \ell}{24}$
[c]	$\frac{qa(\ell - a)}{\ell}$	$-\frac{qa^2}{\ell}$
[d]	<ul style="list-style-type: none"> <li>Types 1 or 5 bottom valves: 0</li> <li>Type 2 bottom valve (1): <math>-\frac{R_2(2a + c_1)(2\ell - 2a - c_1)}{4\ell}</math></li> <li>Type 3 or 4 bottom valves: <math>-\frac{R_2[4a(\ell - a) - c_1^2]}{2\ell}</math></li> </ul>	<ul style="list-style-type: none"> <li>Types 1 or 5 bottom valves: 0</li> <li>Type 2 bottom valve: <math>\frac{R_2(2a + c_1)^2}{4\ell}</math></li> <li>Type 3 or 4 bottom valves: <math>\frac{R_2[4a^2 + c_1^2]}{2\ell}</math></li> </ul>
[e]	$\frac{F_1 \ell}{8}$	$-\frac{F_1 \ell}{8}$
[f]	$-\frac{F_2 \ell}{8}$	$\frac{F_2 \ell}{8}$

(1) Formula valid for a hinge on cellular keel. In the case of a hinge on lateral wing tank, replace  $(2a + c_1)$  with  $(2a - c_1)$

**7.2.9** When the ship is to navigate with empty hopper space(s), the buckling of the upper flange is to be checked, using the formulae given in [7.3] for strong beams and assuming that:

$$F_R = \frac{-3,3S_a}{2D - h_v}(T_2 + 0,5h_0)^2(3D - T_2 - 0,5h_0)\frac{A_s}{A_v}$$

where:

$T_2$  : Maximum draught for navigation with empty hopper space(s), in m

$A_s$  : Sectional area, in cm<sup>2</sup>, of the upper flange

$A_v$  : Sectional area, in cm<sup>2</sup>, of the floor, cut-outs in web deducted.

### 7.3 Strong beams at deck level

**7.3.1** Where strong beams are fitted at deck level, the forces acting on them are to be obtained, in kN, from the following formulae:

- tension force due to the spoil pressure onto the longitudinal bulkheads of the well:

$$F_T = \frac{1,6\delta s(D + h_D)^2}{2D - h_v}[2(D + h_D) - 3h_v]$$

- compression force due to the external hydrostatic pressure:

$$F_{C1} = \frac{1,6s(T_D - 0,5h_0)^2}{2D - h_v}(2T_D - h_0 - 3h_v)$$

- compression force due to moment at floor ends:

$$F_{C2} = \frac{2M(0)}{2D - h_v}$$

- compression force due to floor reaction at span ends:

$$F_{C3} = \frac{d_1 + 2b_1}{2D - h_v}T(0)$$

where:

$s$  : Spacing of strong beams, in m

$d_1$  : Distance, in m, from the side plating to the longitudinal bulkhead of the hopper well

$b_1$  : Distance, in m, between the fixed end of the floor and the hopper well longitudinal bulkhead or its extension

$M(0), T(0)$ : Total bending moment and shear force at fixed ends, determined, respectively, according to [7.2.5] and [7.2.4], for  $X = 0$ .

For strong beams with a large web depth, the upper flange of which is located at deck level, the term  $D$  may be replaced by  $(D - 0,5h_{WS})$ , where  $h_{WS}$  is the web depth, in m, of strong beams.

The resultant of the forces is to be obtained, in kN, from the following formula:

$$F_R = F_T - F_{C1} - F_{C2} - F_{C3}$$

$F_R$  is a tension load when positive, a compression load when negative.

**7.3.2** The sectional area of strong beams, after deduction of possible cut-outs, is to be obtained, in cm<sup>2</sup>, from Tab 13.

## 7.4 Brackets for trunks

**7.4.1** Brackets for trunks are to be provided in way of the strengthened transverse rings. They are to be securely fixed at their lower ends.

**7.4.2** In order to check the stresses according to [7.4.3], the value of the bending moment at the lower end, in kN.m, and the value of the corresponding shear stress, in kN, may be obtained, respectively, from the following formulae:

$$M_p = 1,64\delta sh_T^3$$

$$T_p = 4,9\delta sh_T^2$$

where:

$h_T$  : Height, in m, of the trunk above the deck-line.

**7.4.3** It is to be checked that the normal stress, in N/mm<sup>2</sup>, and the shear stress are respectively in compliance with the following formulae:

$$\sigma \leq 0,65 \frac{R_{eH}}{k}$$

$$\tau \leq 0,45 \frac{R_{eH}}{k}$$

**Table 13 : Sectional area of strong beams**

Condition	Sectional area $A_T$ , in cm <sup>2</sup>
$F_R \geq 0$	$0,08 F_R$
$F_R < 0$	<ul style="list-style-type: none"> <li>• when <math>\ell_F/r \leq 1,15</math>:  <math display="block">\left[ 0,085 + 0,064 \left( \frac{\ell_F}{r} \right)^2 \right] F_R</math> </li> <li>• when <math>\ell_F/r &gt; 1,15</math>:  <math display="block">0,1 \left( \frac{\ell_F}{r} \right)^2 F_R</math> </li> </ul>
<b>Note 1:</b>	
$\ell_F$	: Buckling length, in m, of the strong beam considered as fixed at ends, to be taken equal to $0,5 \ell_0$
$r$	: Minimum gyration radius, in cm, to be taken equal to: $r = \sqrt{\frac{I}{A_T}}$
$I$	: Moment of inertia, in cm <sup>4</sup> , equal to the minimum of $I_{xx}$ and $I_{yy}$
$I_{xx}$	: Moment of inertia, in cm <sup>4</sup> , with respect to the axis perpendicular to the plane of the web
$I_{yy}$	: Moment of inertia, in cm <sup>4</sup> , with respect to the axis parallel to the plane of the web.

## 7.5 Girders supporting the hydraulic cylinder in the hopper spaces (bottom door types 1, 2 and 3)

**7.5.1** In order to check the stresses according to [7.5.2], the local bending stress due to the cylinder reaction and the corresponding shear stress, in N/mm<sup>2</sup>, may be obtained, respectively, from the following formulae:

$$\sigma_{LX} = \frac{125F\ell}{w}$$

$$\tau_{XY} = \frac{5F}{A_a}$$

where:

$F$  : Maximum value, in kN, of  $R_1$  and  $F_M$  defined in [7.2.3]

$w$  : Girder web modulus, in cm<sup>3</sup>

$A_a$  : Girder web sectional area, in cm<sup>2</sup>, possible cut-outs deducted.

**7.5.2** It is to be checked that the normal stress, in N/mm<sup>2</sup>, and the shear stress are respectively in compliance with the following formulae:

$$\sigma \leq 0,65 \frac{R_{eH}}{k}$$

$$\tau \leq 0,45 \frac{R_{eH}}{k}$$

## 8 Split hopper dredgers and split hopper units: superstructure hinges

### 8.1 General

**8.1.1** For ships with either of the service notations **split hopper dredger** or **split hopper unit**, a check of the superstructure hinges according to [8.5] is to be carried out considering the forces defined in [8.4].

### 8.2 Arrangements

**8.2.1** Chocks able to withstand the longitudinal forces induced by the superstructures are generally to be fitted on the deck located below the superstructures.

**8.2.2** When the chocks are fitted on one side only, attention is to be paid to the longitudinal take over of forces by the hinges located on the side opposite to the chocks.

**8.2.3** Chocks are to be able to work when the half-hulls swing apart to discharge the spoil.

**8.2.4** Special attention is to be paid to the reinforcement below the deck in way of the hinges and chocks, as well as to the fixing of the hinge to the strength members of the superstructures.

The scantlings of these members are to be calculated considering the forces given in [8.4.3] applied at the level of the hinge pin.

**8.2.5** Generally, no cut-out is to be fitted immediately near to hinges or chocks.

### 8.3 Materials used for the hinges

#### 8.3.1 Grades of hull steel plates

In normal service conditions, the hull steel plates are to be of the grade defined in Tab 14.

**Table 14 : Material grade requirements for superstructure hinges**

Gross thickness, in mm	Normal strength steel	Higher strength steel
$t \leq 20$	A	AH
$20 < t \leq 25$	D	DH
$25 < t \leq 30$	E	DH
$t > 30$	E	EH

Moreover, in low temperature service conditions, the choice of the steel grade is to be made with the Society on a case-by-case basis, according to the actual service conditions and to the design detail of the welded assembly.

#### 8.3.2 Grades of steel castings and steel forgings

The steel grade of the steel castings and steel forgings is to be defined according to the service temperature of the part and to the weld location on the part.

#### 8.3.3 Grades of steel for hinge pins

The hinge pins are generally to be made of forged steel.

In addition to the rule checks defined in Part D, Chapter 2, a series of impact tests is to be carried out on three Charpy V test pieces and the minimum mean value of impact energy KVL is to be equal to or greater than 27 J at 0° C.

#### 8.3.4 Inspections and tests of weld connections

For welds concerning the main members of the hinges, non-destructive examinations are to be carried out along the full length of the joint:

- for butt welds: 100% radiographic and ultrasonic examination
- for fillet welds with deep penetration: 100% ultrasonic examination and 100% magnetic particle inspection or penetrant fluid test
- for fillet welds with small penetration: 100% magnetic particle inspection or penetrant fluid tests.

### 8.4 Forces

**8.4.1** The forces defined in [8.4.2] to [8.4.4] may be replaced by results from model tests or by representative calculations.

In such case, the method used and the assumed conditions for model tests or calculation are to be submitted to the Society for information.

**8.4.2** The forces applied on superstructures are to be obtained, in kN, from the following formulae:

- in x direction:

$$F_x = F_{w,x}$$

- in y direction:

$$F_y = F_{w,y}$$

- in z direction:

$$F_z = F_s + F_{w,z}$$

where  $F_s$ ,  $F_{w,x}$ ,  $F_{w,y}$ ,  $F_{w,z}$  are to be obtained from the formulae in Pt B, Ch 5, Sec 6, [5] or Pt B, Ch 8, Sec 1, [5.4], as applicable, in which  $M$  is, in  $t$ , the mass of the superstructures.

**8.4.3** In the case of superstructures connected to the ship by means of two simple hinges and two hinges with connecting tie-rods (as shown in Fig 21 and Fig 22), the forces are to be obtained, in kN, from the following formulae:

- force in line with a tie-rod:

$$F = \frac{1}{\cos\beta} \left( \frac{1}{2} + \frac{\varepsilon_L}{d_L} \right) \left[ \left( \frac{1}{2} - \frac{\varepsilon_T}{d_T} \right) F_z + \frac{d_V}{d_T} F_y \right]$$

- vertical force in a simple hinge:

$$F = \left( \frac{1}{2} + \frac{\varepsilon_L}{d_L} \right) \left[ \left( \frac{1}{2} + \frac{\varepsilon_T}{d_T} \right) F_z + \frac{d_V}{d_T} F_y \right]$$

- transverse force in a hinge:

$$F = \left( \frac{1}{2} + \frac{\varepsilon_L}{d_L} \right) \left[ \left( \frac{1}{2} - \frac{\varepsilon_T}{d_T} \right) F_z \tan\beta + \left( 1 - \frac{d_V}{d_T} \tan\beta \right) F_y \right]$$

- longitudinal force for each chock:

$$F = \frac{F_x}{n_B}$$

where:

$\beta$  : Angle of tie-rods with respect to the vertical line, in degrees

$d_T$  : Transverse distance between a simple hinge and a tie-rod hinge, in m

$d_V$  : Vertical distance from the centre of gravity of the superstructures to the horizontal plane passing through the hinge centreline, in m

$d_L$  : Longitudinal distance between the fore and aft hinges, in m

$\varepsilon_T$  : Transverse eccentricity of the centre of gravity of the superstructures (taken as positive if the centre of gravity is on the side of the simple hinges, and as negative otherwise), in m

$\varepsilon_L$  : Longitudinal eccentricity of the centre of gravity of the superstructures (positive), in m

$n_B$  : Number of longitudinal chocks.

Where a longitudinal chock is provided on one side only, the hinges are to be able to withstand the longitudinal force  $F_x$ .

The distribution of forces in the case of other arrangements is to be examined by the Society on a case-by-case basis.

**Figure 21 : Connection between superstructure and ship - Transverse direction**

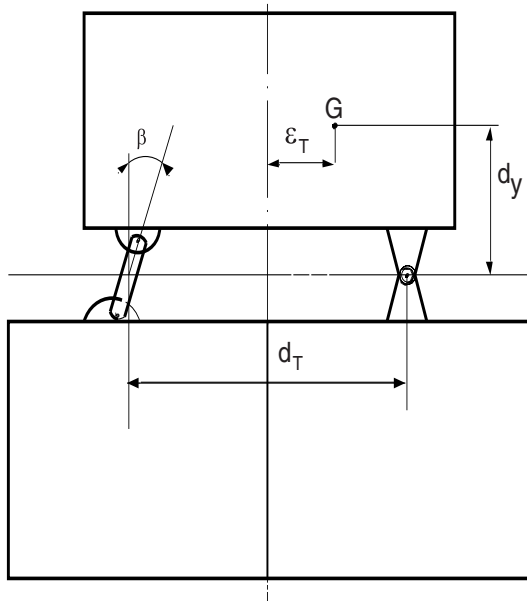

**Figure 22 : Connection between superstructure and ship - Longitudinal direction**

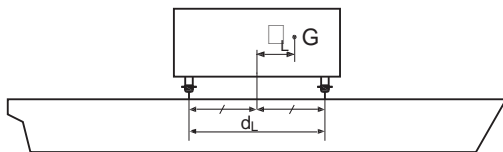

**8.4.4** The force  $F$  to be considered for the check of the hinge scantlings is to be taken equal to:

- for a simple hinge: the resultant of the horizontal and vertical forces
- for a hinge with tie-rod: the force in the tie-rod centreline

Moreover, the horizontal force in the hinges due to withstanding of the longitudinal force  $F_x$  in the case of a horizontal chock on one side only is to be considered alone.

**8.5 Scantlings of the hinges**

**8.5.1** The hinges consist generally of two side straps and a centre eye connected by a pin, as shown in Fig 23.

**Figure 23 : Superstructure hinge arrangement**

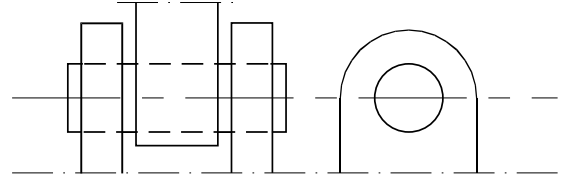

The two main types of hinges are generally the following:

- type I: welded assembly made of plates, as shown in Fig 24,
- type II: welded assembly made of plates and of cast steel or forged steel parts, as shown in Fig 25.

The check of scantlings in [8.5.2] applies to the case of direct bearing of the pin on the side straps and the centre eye (see Fig 26) and to the case of load transfer by bearings (see Fig 27). In the second case, the designer is to demonstrate that the bearings can withstand the calculated forces.

Hinges whose manufacture is different from these two cases are to be examined by the Society on a case-by-case basis.

**8.5.2** For the pins, centre eye and side straps of the hinges, the applied forces are to comply with the formulae given in Tab 15.

**Figure 24 : Type I superstructure hinges**

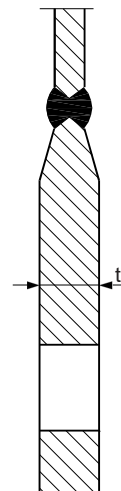





Table 15 : Scantling check of superstructures hinges

Case	Elements to be checked		
	Pins	Centre eye	Side straps
Direct bearing	$F < \frac{d_a^2 R_m}{5,76} 10^{-3}$ $F < \frac{2}{3} d_a t_0 R_{eH} 10^{-3}$ <ul style="list-style-type: none"> <li>if <math>t_0 &lt; d_a</math>:           <math display="block">F &lt; \frac{d_a^3}{2D_C - t_0} \frac{R_m}{5} 10^{-3}</math> </li> <li>if <math>t_0 \geq d_a</math>:           <math display="block">F &lt; \frac{d_a^3}{2D_C - 2t_0 + d_a} \frac{R_m}{5} 10^{-3}</math> </li> </ul>	$F < \frac{b_0 t_0 R_{eH}}{2,27} 10^{-3}$ $F < d_a t_0 R_{rad} 10^{-3}$	$F < \frac{b_C t_C R_{eH}}{1,14} 10^{-3}$ $F < 2 d_a t_C R_{rad} 10^{-3}$
Load transfer by bearings	$F < \frac{d_a^2 R_m}{5,76} 10^{-3}$ $F < \frac{2}{3} d_a t_3 R_{eH} 10^{-3}$ <ul style="list-style-type: none"> <li>if <math>t_3 &lt; d_a</math>:           <math display="block">F &lt; \frac{d_a^3}{2D_{C1} - t_3} \frac{R_m}{5} 10^{-3}</math> </li> <li>if <math>t_3 \geq d_a</math>:           <math display="block">F &lt; \frac{d_a^3}{2D_{C1} - 2t_3 + d_a} \frac{R_m}{5} 10^{-3}</math> </li> </ul>	$F < \frac{b_0 t_0 R_{eH}}{2,27} 10^{-3}$ $F < \frac{2}{3} d_{a0} t_1 R_{eH} 10^{-3}$	$F < \frac{b_C t_C R_{eH}}{1,14} 10^{-3}$ $F < \frac{4}{3} d_{aC} t_2 R_{eH} 10^{-3}$
<b>Note 1:</b> $R_{rad}$ : Admissible radial pressure on the bearing, to be taken equal to 100 N/mm <sup>2</sup> .			

## 9 Split hopper dredgers and split hopper units: decks hinges, hydraulic jack connections and chocks

### 9.1 General

**9.1.1** For ships with either of the service notations **split hopper dredger** or **split hopper unit**, the scantlings of the deck hinges and the hydraulic jack attachments connecting the two half-hulls are to be determined by direct calculation.

The loads to be considered are the result of the most unfavourable combination of simultaneous static and dynamic forces (see [9.3] and [9.4]), calculated for the loading conditions in [3.2.1].

**9.1.2** The locking devices of the two half-hulls, if any, are to be examined by the Society on a case-by-case basis.

### 9.2 Arrangements

**9.2.1** Transverse chocks to be used upon closing the two half-hulls are to be provided in the bottom area, preferably in way of the hydraulic cylinders. These chocks may consist of heavy plates inserted in the bottom plating. They are to

be arranged to come into contact before the end of the stroke of the jack, upon closing.

Moreover, if the calculation of the longitudinal strength is carried out assuming the hopper well ends are partly fixed, transverse chocks are to be provided at deck level.

**9.2.2** Longitudinal chocks are to be provided at bottom and deck level, to prevent relative displacement of the two half-hulls.

Deck longitudinal chocks must also act in the open position.

For units of a capacity less than 700 m<sup>3</sup>, longitudinal deck chocks need not be provided; in such case, one of the two deck hinges is to be designed to fulfil the function of a chock. The other hinge is then to have sufficient clearance.

### 9.3 Static forces

**9.3.1** The method of calculation in [9.3.2] to [9.3.9] enables the determination of the static forces in the hydraulic jack, in the chocks and in the deck hinges only if the following conditions are met:

- the total number of hydraulic jacks connecting the two half-hulls is even
- there are no superposed jacks in the same section
- there is a deck hinge at each end of the hopper well.

Any other arrangement is to be examined by the Society on a case-by-case basis.

**9.3.2** In the case of maximum loading corresponding to the dredging freeboard, the forces exerted on a half-hull to be considered to calculate the static forces in the hinges, transverse bottom chocks and jacks are shown in Fig 28 as well as their lever arm in relation to the  $\lambda$ deck hinge pins.

**9.3.3** The horizontal static forces to be considered are the following:

- horizontal hydrostatic buoyancy  $F_h$  on the full length of the well, in kN. This force takes into account the hydrostatic buoyancy due to the water located between the two half-hulls below the sealing joint situated at the lower part of the hopper well, taken equal to:
 
$$F_h = 5,026 (T_D - a)^2 \ell_p$$
- horizontal pressure of the spoil  $F_d$ , in kN, taken equal to:
 
$$F_d = 4,904 \delta (h_1 - a)^2 \ell_p$$
- force  $F_{CY}$  in each jack, in kN, equal to the greater of  $F_{MC}$  and  $F_p$
- force  $F_{CH}$  in each hinge, in kN, taken equal to:

$$F_{CH} = 0,5 \left[ F_h - F_d + n_1 \left( 1 - \frac{a_3}{a_4} \right) F_{CY} + \frac{M}{a_4} \right]$$

- force  $F_B$  in each bottom transverse chock, in kN, taken equal to:

$$F_B = \frac{n_1 a_3 F_{CY} - M}{n_2 a_4}$$

where:

$F_{MC}$  : Minimum force required to keep the dredger closed in the loading case considered, obtained from the following formula:

$$F_{MC} = M/n_1 a_3$$

For a tendency to close,  $F_{MC}$  is negative and is not to be taken into account to determine  $F_{CY}$ .

$F_p$  : Force in the jack corresponding to a pressure on the rod side equal to the maximum pressure  $P_p$  of the pumps and of their pressure limiting device

$M$  : Moment with respect to the hinge chocks, positive for a tendency to open, negative in the opposite case, taken equal to:

$$M = -F_h a_1 + F_d a_2 + \frac{1}{2} (\Delta b_1 - \Delta_1 \alpha b_2 - Q b_3)$$

$n_1$  : Number of jacks

$n_2$  : Number of bottom transverse chocks

$\Delta, \Delta_1, \ell, Q$ : Vertical forces, defined in [9.3.4]

$a_1, a_2, a_3, a_4$ : Lever arms of horizontal forces, as shown in Fig 28

$b_1, b_2, b_3$ : Lever arms of vertical forces, as shown in Fig 28.

**9.3.4** The vertical static forces to be considered are the following:

- vertical hydrostatic buoyancy  $\Delta/2$  on a half-hull, in kN
- weight  $\Delta_1 \ell/2$  of the half-hull without spoil, in kN
- weight  $Q/2$  of the half spoil loading, in kN

where:

$\Delta$  : Total displacement of the ship with spoil

$\Delta_1 \ell$  : Total displacement of the ship without spoil, including superstructures

$Q$  : Total weight of the spoil in the well.

The following relation between vertical static forces is to be verified:

$$\Delta = \Delta_1 \ell + Q$$

**Figure 28 : Forces exerted on a half-hull**

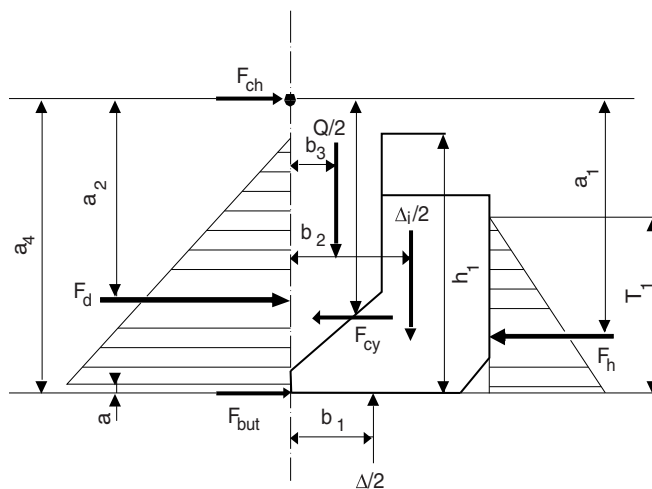

**9.3.5** For every other loading case, the forces  $F_{CY}$ ,  $F_{CH}$  and  $F_B$  are to be calculated according to [9.3.4], by replacing:

- $a_1, a_2, b_1, b_2, b_3, \Delta, \Delta_1 \ell$  and  $Q$  by the corresponding values for the loading case considered

- $T_D, \delta$  and  $h_1$  by values of external draught, density of water or spoils in the well and level inside the well for the loading case considered, i.e.:

- in working condition, at the international freeboard:  $T, \delta$  and  $h_2$

- in navigation condition with the well filled up to the waterline:  $T_3$ , 1,025 and  $h_3$  taken equal to  $T_3$
- in navigation condition with well filled with water to the lowest weir level:  $T_4$ , 1,025 and  $h_4$ .

**9.3.6** If, in the maximum loading condition corresponding to the dredging freeboard or the international freeboard, densities of spoil higher than  $\delta$  may be considered with reduced heights (for constant mass of spoils), calculation of  $F_{CY}$ ,  $F_{CH}$  and  $F_B$  is also to be carried according to [9.3.4], using the parameters corresponding to the maximum densities of spoil likely to be considered with draughts  $T_D$  and  $T$ .

**9.3.7** The maximum static force  $F_S$ , actually developed by the jack, is the greatest of the values obtained for  $F_{CY}$  for the various loading cases and calculated according to [9.3.4], [9.3.5] and [9.3.6].

**9.3.8** Where the hopper well ends are partly fixed, the end moments result in additional forces in the deck hinges, jacks, deck and bottom chocks, forward and aft of the well.

The distribution of these forces is to be determined by a direct calculation to be submitted to the Society for approval.

**9.3.9** The Designer is to give the value of the horizontal lever arm  $b_2$  and the hull weight for the various loading cases as stated in [9.3.4]. In each case, the value to be taken into account is the most unfavourable one according to the distribution of the compartments, considering the tendency to open or to close.

However, the attention of the Owner and of the Designer is drawn to the fact that side tank ballasting can noticeably reduce the static forces necessary in the jacks to act against opening of the two half-hulls in the above operating conditions.

## 9.4 Dynamic forces

**9.4.1** The Designer is to give the dynamic forces applied on the deck hinges and on the hydraulic jack attachments by means of a calculation to be submitted to the Society for approval.

**9.4.2** The dynamic forces are generally to be calculated by means of a long-term statistical analysis, under the conditions defined in Tab 16.

**9.4.3** For each rule loading case, the results of the calculation are to give:

- the dynamic force  $F_{DCY}$  in each jack, in kN
- the horizontal dynamic force  $F_{DHC}$  in each hinge, in kN
- the vertical dynamic force  $F_{DVC}$  in each hinge, in kN.

**Table 16 : Probability for the determination of dynamic forces**

Condition	Probability
Dredging and navigation with spoil, with sea state limited to $H_s = 3$ m (1)	$10^{-5}$ for jacks and hinges
Navigation without spoil, without limitation on sea state (2)	$10^{-7}$ for jacks $10^{-5}$ for hinges
<p>(1) <math>H_s</math> : Significant wave height, in m.            (2) In sailing condition without spoil, a different probability level may be adopted for the calculation of dynamic forces on the cylinders, subject to the Society's agreement, when a device intended to restore the pressure to the cylinders after opening of the safety valves is fitted (see also [10.3.1]).</p> <p><b>Note 1:</b> Different calculation conditions are to be justified by the Designer.</p>	

**9.4.4** If loading cases other than those defined in [3] are considered, calculations for such additional cases are to be defined in agreement with the Society on a case-by-case basis.

**9.4.5** In the case of dredgers with a capacity of less than 700 m<sup>3</sup>, the dynamic forces in the jacks and hinges may be taken into account without long-term statistical calculations. The calculations for jacks and hinges are to be justified to the Society.

**9.4.6** For ships with either of the navigation notations **coastal area** and **sheltered area**, the dynamic forces in the cylinders and the hinges may be reduced by 10% in the case of navigation without spoil.

## 9.5 Scantlings

**9.5.1** The maximum total force in the jack is to be taken equal to the greatest value, from all the loading cases foreseen, obtained, in kN, from the following formula:

$$F_m = F_{CY} + F_{DCY}$$

The jack is to be capable of developing a force at least equal to  $F_m$ , at the setting pressure of the safety valve of the jack considered as isolated.

**9.5.2** The scantlings of the jack lugs are to comply with [8.5] considering the force  $F_m$  as determined in [9.5.1]. Cases where the force developed by the jack, at the setting pressure of the safety valve of the jack considered as isolated, is noticeably higher than  $F_m$  are to be examined by the Society on a case-by-case basis.

**9.5.3** The scantlings of the deck hinges are to comply with [8.5], considering the resultant of the total horizontal force and the total vertical force, obtained, in kN, from the following formula:

$$F_{Res} = \sqrt{(F_{CH} + F_{DCH})^2 + F_{DVC}^2}$$

**9.5.4** The scantling load of the transverse bottom chocks is to be defined in agreement with the Society.

**9.5.5** The scantlings of the longitudinal bottom chocks provided for in [9.2.2] are to be determined considering for each chock the force obtained, in kN, from the following formula:

$$F = 0,15 \frac{\Delta_m}{n_3}$$

where:

$\Delta_m$  : Maximum displacement of the ship, in kN, with the well loaded with spoil

$n_3$  : Total number of chocks (at deck and bottom).

The scantlings of the longitudinal deck chocks mentioned in [9.2.2] are to be determined considering for each chock the force obtained, in kN, from the following formula:

$$F = 0,15 \frac{\Delta_n}{n_4}$$

where:

$\Delta_n$  : Displacement of the ship with the well filled with water up to the waterline

$n_4$  : Number of longitudinal deck chocks.

The permissible shear stress for bottom and deck chocks is to be obtained, in N/mm<sup>2</sup>, from the following formula:

$$\tau = 0,9 \frac{R_{eH}}{\sqrt{3}}$$

For the calculation of the shear stress in the deck chocks, a reduced sectional area corresponding to the efficient sectional area of the chocks when the well is open is to be considered.

**9.5.6** The lugs of the jacks and the deck hinges may be calculated using a finite element model.

In such case, the finite element model and the applied loadings are to be preliminarily agreed upon by the Society.

The permissible stress is to be defined in agreement with the Society, depending on the finite element model and on the characteristics of the materials.

## 10 Split hopper dredgers and split hopper units: hydraulic jacks and associated piping systems

### 10.1 General

**10.1.1** For ships with either of the service notations **split hopper dredger** and **split hopper unit**, the check of hydraulic jacks and associated piping systems intended for closing the two half-hulls of the ship is to be carried out according to [10.1] to [10.6].

**10.1.2** Hydraulic jack design and construction are to be in accordance with the applicable requirements of Pt C, Ch 1, Sec 11, [2], while associated piping systems are generally to fulfil the relevant requirements of Pt C, Ch 1, Sec 10.

Materials used are to be in accordance with the applicable requirements of Part D.

### 10.2 Definitions

**10.2.1** For the checking of hydraulic jacks and associated piping systems, the following definitions are to be considered:

$P_m$  : Pressure on the rod side of the jack resulting from the extreme foreseen ambient conditions corresponding to the maximum force  $F_m$ , defined in [9.5.1]

$P_C$  : Maximum pressure on the bottom side of the cylinder equal to the setting value of the safety valves protecting the bottom side of the cylinder

$P_p$  : Maximum pressure which can be delivered through the pumps and their associated pressure limiting devices

$P_s$  : Pressure on the rod side of the jack corresponding to the greatest of forces  $F_s$ , defined in [9.3.7], and  $F_p$ , defined in [9.3.3].

### 10.3 Arrangements

**10.3.1** When large ships are concerned, the following arrangements are generally to be provided:

- for each hydraulic jack, a measuring system of the pressure in the cylinder is to be supplied
- this system, in addition to the indication of the pressure at the bridge and at the dredging room, is to comprise a visual and audible alarm at the same locations, to be activated when a certain limit is exceeded
- the measuring system, the alarm activating limit as well as the instructions to be followed after the alarm occurs are to be submitted to the Society for approval.

**10.3.2** Special attention is to be paid to protection against corrosion.

### 10.4 Scantling of jacks

**10.4.1** For the pressure parts of hydraulic jacks made of steel, the permissible stress related to the loading conditions resulting in pressure  $P_p$  or  $P_s$  (whichever is the greater) acting on the cylinder rod side without pressure on the other side is to be taken as the smaller of  $R_{eH}/1,8$  and  $R_m/2,7$ .

The allowable stress applicable to the cylindrical envelope, for the loading conditions resulting in pressure  $P_m$ , may be taken as the smaller of  $R_{eH}/1,5$  and  $R_m/2,25$ .

**10.4.2** The scantlings of the jack end cover on the rod side are to be determined using  $P_m$  as design pressure.

The scantlings of the jack end cover on the bottom side as well as the mechanical connections (for example the bolts between the cover and the cylinder or between the piston and the rod) are to be based on  $F_m$ .

The calculations justifying the proposed scantlings and, as the case may be, the pre-stresses are to be submitted to the Society for approval.

**10.4.3** The scantlings of the rod are to be based on  $F_m$  and on the smaller value of  $R_{eH}/2$  and  $R_m/2,4$ , for the mean

permissible stress in traction. A calculation proving the adequate buckling strength of the rod is to be submitted to the Society for approval.

**10.4.4** The scantlings of the lugs and the pins at each end of the hydraulic cylinder are to be based on  $F_m$ .

## 10.5 Inspection and testing

**10.5.1** In addition to inspections required in [10.1.2], where applicable, welded joints connecting parts subject to the load  $F_m$  are to fulfil the requirements for class 1 pressure vessels or equivalent.

**10.5.2** Completed cylinders and attached piping up to and including the first isolating valve are to undergo, at works, a pressure test at the greater of the values  $1,4P_s$  and  $1,2P_m$  applied on the rod side and a pressure test at  $1,4P_c$  on the bottom side for the fully extended position.

**10.5.3** The completed hydraulic circuit is to be subjected, on board, to pressure tests at 1,4 times the relevant maximum service pressure for normal conditions or static loads, for the part of the circuit considered.

## 10.6 Relief valve setting

**10.6.1** At least one relief valve of appropriate capacity is to protect each part of the circuit which may be subject to overpressure due to external loads or due to pump action; in general, relief valves on the rod side of each cylinder or group of cylinders are to be set at  $P_m$ , while  $P_c$  applies to the bottom side for relief valve setting purposes.

Parts of the circuit possibly subject to overpressure from pumps only are to be protected by relief valves set at pressure  $P_p$ .

## 11 Rudders

### 11.1 General

**11.1.1** The rudder stock diameter obtained from Pt B, Ch 10, Sec 1, [4] is to be increased by 5%.

### 11.2 Additional requirements for split hopper dredgers and split hopper units

**11.2.1** Each half-hull of ships with either of the service notations **split hopper unit** or **split hopper dredger** is to be fitted with a rudder complying with the requirements of Pt B, Ch 10, Sec 1.

**11.2.2** An automatic system for synchronising the movement of both rudders is to be fitted.

## 12 Equipment

### 12.1 General

**12.1.1** The requirements of this Article apply to ships having normal ship shape of the underwater part of the hull.

For ships having unusual ship shape of the underwater part of the hull, the equipment is to be considered by the Society on a case-by-case basis.

**12.1.2** The equipment obtained from [12.1.4] or [12.1.5] is independent of anchors, chain cables and ropes which may be needed for the dredging operations.

**12.1.3** The Equipment Number EN is to be obtained from the following formula:

$$EN = 1,5(LBD)^{2/3}$$

When calculating EN, bucket ladders and gallows may not be included.

**12.1.4** For ships equal to or greater than 80 m in length and for ships with EN, calculated according to [12.1.3], equal to or greater than 795, the equipment is to be obtained from Pt B, Ch 10, Sec 4, [3], with EN calculated according to Pt B, Ch 10, Sec 4, [2] and not being taken less than 795, considering the following:

- to apply the formula, the displacement considered is that of the navigation draught, taking into account the cylinder housings and the free space between the two half-hulls
- the chain cable diameter is to be read off after moving to the next line below in the applicable Table.

**12.1.5** For ships other than those defined in [12.1.4], the equipment is to be obtained from Tab 17.

Where such ships are assigned one of the following navigation notations:

- summer zone
- tropical zone
- coastal area,

the equipment is to be obtained by consulting Tab 17 one line higher.

Where such ships are assigned the navigation notation **sheltered area**, the equipment is to be obtained by consulting Tab 17 two lines higher.

Table 17 : Ships for dredging activities - Equipment

Equipment number EN A < EN ≤ B		Stockless anchors		Stud link chain cables for anchors	
A	B	N	Mass per anchor, in kg	Total length, in m	Diameter, in mm
35	45	2	120	110,0	16,0
45	60	2	140	110,0	17,5
60	80	2	220	110,0	19,0
80	92	2	260	137,5	20,5
92	102	2	290	137,5	22
102	112	2	320	165,0	24
112	130	2	350	165,0	24
130	155	2	430	165,0	26
155	185	2	500	165,0	28
185	210	2	600	165,0	30
210	250	2	700	165,0	32
250	285	2	800	220,0	34
285	315	2	900	220,0	36
315	350	2	1000	220,0	38
350	385	2	1100	220,0	38
385	415	2	1200	220,0	40
415	450	2	1300	220,0	40
450	485	2	1400	220,0	42
485	515	2	1500	220,0	44
515	550	2	1600	220,0	46
550	585	2	1700	220,0	48
585	635	2	1800	275,0	48
635	685	2	2000	275,0	50
685	715	2	2100	275,0	52
715	750	2	2200	275,0	54
750	795	2	2300	275,0	54

**12.1.6 (1/7/2024)**

Dredgers with unusual design of the underwater part of the hull are not covered by alternative methodology using direct force calculation for anchoring equipment described in Pt B, Ch 10, App 4.

**12.2 Additional requirements for split hopper dredgers and split hopper units**

**12.2.1** Arrangements of ships with either of the service notations **split hopper dredger** or **split hopper unit** are to be in accordance with [12.2.2] to [12.2.5].

**12.2.2** One chain locker and one complete mooring chain cable are generally to be provided for each half-hull.

**12.2.3** If the mass of the anchor permits, only one windlass needs to be provided on either of the half-hulls. In this case, in addition to the requirements in Pt B, Ch 10,

Sec 4, [3], a chain stopper is to be fitted on the half-hull which is not equipped with a windlass.

**12.2.4** Fairleads or rollers are to be located in suitable places between the windlass and the hawse pipe so that the dropping and the housing of the anchor are satisfactorily ensured.

**12.2.5** Arrangements are to be made to avoid jamming of the cable during the opening and closing operations of the two half-hulls.

**12.3 Towlines and mooring lines**

**12.3.1** For ships equal to or greater than 80 m in length and ships with EN, calculated according to [12.1.3], greater than 795, the characteristics of towlines and mooring lines are to be obtained from Pt B, Ch 10, Sec 4, [3] with EN calculated according to Pt B, Ch 10, Sec 4, [2], considering

the displacement at navigation draught, taking into account the cylinder housings and the free space between the two half-hulls, the latter value of EN not being less than 795.

**12.3.2** For ships other than those defined in [12.3.1], the characteristics of towlines and mooring lines are to be obtained from Tab 18.

**Table 18 : Ships for dredging activities - Towlines and mooring lines (1/1/2022)**

Equipment number EN $A < EN \leq B$		Towline (1)		Mooring lines		
A	B	Minimum length, in m	Ship Design Minimum Breaking Load, in kN	N	Length of each line, in m	Ship Design Minimum Breaking Load, in kN
35	45	120	88	2	90	59
45	60	120	93	2	90	64
60	80	120	98	2	90	68
80	92	130	107	2	90	73
92	102	130	117	2	110	78
102	112	130	127	2	110	83
112	130	140	137	2	110	88
130	155	140	147	2	135	93
155	185	140	156	2	135	98
185	210	150	166	2	135	102
210	250	150	176	2	135	107
250	285	150	186	2	135	112
285	315	150	196	2	135	117
315	350	160	215	2	160	122
350	385	160	240	2	160	127
385	415	160	265	2	160	132
415	450	160	295	2	160	137
450	485	160	320	2	160	142
485	515	160	340	3	160	147
515	550	160	365	3	160	152
550	585	160	390	3	160	157
585	635	160	415	3	160	161
635	685	160	440	4	160	166
685	715	160	465	4	160	170
715	750	160	490	4	160	175
750	795	180	515	4	160	180

(1) The towline is not compulsory. It is recommended for ships having length not greater than 180 m.

## SECTION 3

## MACHINERY AND DREDGING SYSTEMS

### 1 General

#### 1.1 Application

**1.1.1** This Section provides requirements for ships having the service notation **dredger, hopper dredger, hopper unit, split hopper unit** and **split hopper dredger**. These requirements are only applicable at the request of an Owner.

**1.1.2** This Section does not cover the other aspects of the system and equipment design, in particular in respect of their performance.

**1.1.3** The requirements for bottom doors and valves fitted on ships having the notation **hopper dredger, hopper unit, split hopper unit** and **split hopper dredger** are given in Sec 2.

#### 1.2 Documents to be submitted

**1.2.1** The documents listed in Tab 1 are to be submitted for approval.

### 2 Dredging system

#### 2.1 General

##### 2.1.1 Mechanical strength

The systems intended for dredging operations and their components are to be of sufficient mechanical strength based on the maximum loads expected in service, as specified by the Designer.

##### 2.1.2 Piping systems

The piping systems intended for:

- suction or discharge of spoils or dredged materials
- the hydraulic supply of bottoms doors or valve actuators, cutting teeth, etc.

are to be designed, constructed and tested in accordance with the applicable provisions of Pt C, Ch 1, Sec 10.

##### 2.1.3 Pressure vessels

Where provided, pressure vessels are to be designed, constructed and tested in accordance with the applicable provisions of Pt C, Ch 1, Sec 3.

#### 2.2 Design of the dredging system components

##### 2.2.1 Dredging pump units

- a) In order to take into account the impact of the pump impeller on the dredged materials, diesel engines driving dredging pumps are to be designed considering an additional torque of 15% of the nominal torque.
- b) The flexible couplings fitted to dredging pump units are to be so designed as to withstand the maximum torque expected in service.
- c) Where their power is 110 kW or more, dredging pump units are to comply with the provisions of Pt C, Ch 1, Sec 9 related to torsional vibrations.
- d) Dredging pump impellers are to be made of a weldable material.

##### 2.2.2 Suction and discharge dredging piping

- a) Valves provided on the suction and discharge pipes of the dredging system are to be of a type approved by the Society.
- b) Suction and discharge pipes of the dredging system are to be of extra-reinforced thickness. For steel pipes, refer to Pt C, Ch 1, Sec 10, Tab 5.
- c) A sufficient number of attachment points are to be provided on the suction pipe itself, to facilitate handling.
- d) Accessories fitted onto the suction pipe are to be built in several parts to facilitate partial replacements in case of damage.

**Table 1 : Documents to be submitted**

No.	Document (1)
1	General arrangement of the dredging equipment
2	Design loads on all components of the dredging equipment
3	Structural plans of all components of the dredging equipment, including pressure vessels, hydraulic systems, etc., as applicable
4	Diagram of the piping system intended for dredging and, where applicable, for the transfer of spoils or dredged materials
5	Torsional vibration calculations of the dredging pump units, where their power is 110 kW or more
(1)	Diagrams are also to include, where applicable: <ul style="list-style-type: none"> <li>• the (local and remote) control and monitoring systems and automation systems</li> <li>• the instructions for the operation and maintenance of the piping system concerned (for information).</li> </ul>



### 2.2.3 Cutting teeth

- a) If the suction pipe is equipped with cutting teeth, a load limiting device is to be provided to avoid any overload.
- b) Where cutting teeth are driven by means of a hydraulic motor, an alarm is to be activated in the event of hydraulic oil leakage and the oil supply to the motor is to be stopped.

### 2.2.4 Discharge pipes

Arrangements are to be made to avoid collapse of the pipes used for the discharge of spoils or dredged materials to reception facilities when the discharge pump is stopped.

## 2.3 Attachment of dredging equipment to the hull

**2.3.1** The scantlings of the structure for attachment of the equipment intended for dredging operations (e.g. connection of the suction pipe to the hull, foundation of the suction pipe davits) are to be based on the service load of such equipment, as specified by the Designer.

In determining the above service load, the Designer is to take account of additional loads imposed by ship movements (in particular pitch and heave) in the most unfavourable sea and weather conditions expected during service.

## 3 Steering gear of split hopper dredgers and split hopper units

### 3.1 General

**3.1.1** The rudder fitted to each half-hull of ships having the service notations **split hopper dredger** or **split hopper unit** (see Sec 2, [11.2.1]) is to be served by its own steering gear.

### 3.2 Design of the steering gear

**3.2.1** The steering gear referred to in [3.1.1] is to consist of a control system and a power actuating system capable to operate the relevant rudder as required in Pt C, Ch 1, Sec 11, [3.3.1] or Pt C, Ch 1, Sec 11, [4.3.1], as appropriate.

**3.2.2** An auxiliary steering gear or a duplicated power actuating system need not be fitted.

### 3.3 Synchronisation

**3.3.1** An automatic system for synchronising the movement of both rudders is to be fitted. It is to comply with the provisions of Pt C, Ch 1, Sec 11, [5.2.2].

## 4 Testing of dredging equipment

### 4.1 Workshop testing

#### 4.1.1 General

The dredging equipment is to be tested in compliance with the following requirements, with the exception of prime

movers and pressure vessels (in particular hydraulic accumulators), which are to be tested in compliance with the applicable requirements of the relevant Sections of Part C.

#### 4.1.2 Testing of materials and components of the machinery

- a) In general, testing is required for shafts, gearing, pressure parts of pumps and hydraulic motors, and plates of foundations of welded construction.
- b) As far as mechanical tests of materials are concerned, internal works' certificates submitted by the Manufacturer may be accepted by the Society at its discretion. In such cases, testing operations may be limited to visual external inspection associated, where necessary, with non-destructive examinations and hardness tests.

#### 4.1.3 Hydrostatic tests

Pressure parts are to be subjected to hydrostatic tests in accordance with the relevant requirements of Pt C, Ch 1, Sec 3 or Pt C, Ch 1, Sec 10, as appropriate.

#### 4.1.4 Tests on electrical components

The tests required in Part C, Chapter 2 are to be carried out as applicable.

#### 4.1.5 Running tests

- a) Running tests are to be carried out whenever possible at the Manufacturer's works. As an alternative the above tests may be performed on board during the trials required after installation of machinery.
- b) During the running tests, the suitability of all the arrangements concerned is to be checked in relation to the various expected service conditions.
- c) On completion and subject to the result of the above tests, the inspection of components may be required, with dismantling where deemed necessary by the Surveyor in charge of the testing.

### 4.2 On board testing

#### 4.2.1 Ship trials

- a) Upon completion of construction, in addition to the conventional sea trials required in Pt C, Ch 1, Sec 15, specific tests may be required at the Society's discretion in relation to the particular service for which the ship is intended or the specific characteristics of machinery and equipment fitted on board.
- b) In particular, as regards propulsion and steering systems, tests may be required to check the manoeuvring capability and the speed of the ship whilst operating.

#### 4.2.2 Equipment trials

As far as the dredging system is concerned, tests are to be carried out to verify the proper operation of all relevant equipment in different sea and weather conditions.

Part E  
**Service Notations**

Chapter 14  
**TUGS**

---

**SECTION 1      GENERAL**

**SECTION 2      HULL AND STABILITY**

**SECTION 3      INTEGRATED TUG/BARGE COMBINATION**



# SECTION 1

# GENERAL

## 1 General

### 1.1 Application

**1.1.1** Ships complying with the requirements of this Chapter are eligible for the assignment of one of the following service notations:

- tug
- salvage tug
- escort tug

as defined in Pt A, Ch 1, Sec 2, [4.8.2].

**1.1.2** Ships dealt with in this Chapter are to comply with the requirements stipulated in Parts A, B, C and D, as applicable, and with the requirements of this Chapter, which are specific to tugs.

### 1.2 Summary table

**1.2.1** Tab 1 indicates, for ready reference, the Sections of this Chapter containing specific requirements applicable to tugs.

**Table 1**

Main subject	Reference
Ship arrangement	(1)
Hull and stability	Sec 2
Machinery	(1)
Electrical installations	(1)
Automation	(1)
Fire protection, detection and extinction	(1)
Integrated tug/barge combination	Sec 3
(1) No specific requirements for tugs are given in this Chapter.	

## SECTION 2 HULL AND STABILITY

### 1 General

#### 1.1 Application

##### 1.1.1 (1/7/2022)

The requirements of this Section apply to ships with one of the following service notations:

- **tug**, mainly intended for towing services, which are to comply with the requirements in [2]
- **salvage tug**, having specific equipment for salvage services, which are to comply with the requirements in [2] and [3]
- **escort tug**, mainly intended for escort services such as for steering, braking and otherwise controlling escorted ships, which are to comply with the requirements in [2] and [4].

Ships with the additional service feature **barge combined** (units designed to be connected with barges) are to comply with the applicable requirements in Sec 3.

Ships with the additional service feature **rescue** (units specially equipped for the rescue of shipwrecked persons and for their accommodation) are to comply with the requirements given in [2.11].

Ships with the additional service feature **standby vessel** (units specially intended to perform rescue and standby services) are to comply with the requirements given in [2.12].

Ships with the additional service feature **anchor handling** (units specially designed for anchor handling operations) are to comply with the requirements given in Ch 15, Sec 2, [2.10], [8.3] and [8.5].

Ships with the additional service feature **anchor handling stab** (units specially designed and equipped for anchor handling operation and also fulfilling specific stability requirements related to this service) are to comply with the requirements given in Ch 15, Sec 2, [2.10], [3.4], [8.3] and [8.6].

### 2 Tugs, salvage tugs and escort tugs

#### 2.1 General

**2.1.1** In general, tugs are completely decked ships provided with an ample drift surface and, where intended for service outside sheltered areas, with a forecastle or half forecastle, or at least with a large sheer forward.

Tugs of unusual design are to be considered by the Society on a case-by-case basis.

### 2.2 Stability

#### 2.2.1 Openings (1/1/2021)

a) Openings which cannot be closed weathertight:

Openings in the hull, superstructures or deckhouses which cannot be closed weathertight are to be considered as unprotected openings and, consequently, as down-flooding points for the purpose of stability calculations (the lower edge of such openings is to be taken into account).

b) Ventilation openings of machinery space and emergency generator room:

It is recognised that for tugs, due to their size and arrangement, compliance with the requirements of ICLL Reg. 17(3) for ventilators necessary to continuously supply the machinery space and the emergency generator room may not be practicable. Lesser heights of the coamings of these particular openings may be accepted if the openings:

- are positioned as close to the centreline and as high above the deck as practicable in order to maximise the down-flooding angle and to minimise exposure to green water
- are provided with weathertight closing appliances in combination with suitable arrangements, such as separators fitted with drains
- are equipped with efficient protective louvers and mist eliminators
- have a coaming height of not less than 900 mm above the deck
- are considered as unprotected openings and, consequently, as down-flooding points for the purpose of stability calculations.

#### 2.2.2 Stability booklet (1/1/2021)

The stability booklet for ships engaged in harbour, coastal or ocean going towing operations and/or escort operations is to contain additional information on:

- maximum bollard pull
- details on the towing arrangement, including location and type of the towing point(s) such as towing hook, staple, fairlead or any other point serving that purpose
- recommendations on the use of roll reduction systems
- If any wire, etc. is included as part of the lightship weight, clear guidance on the quantity and size is to be given
- maximum and minimum draught for towing and escort operations
- instructions on the use of the quick-release device

### 2.2.3 Intact stability

The stability of the ship for the loading conditions in Pt B, Ch 3, App 2, [1.2.11] is to be in compliance with the requirements in Pt B, Ch 3, Sec 2.

### 2.2.4 Additional intact stability criteria (1/1/2021)

All the loading conditions reported in the trim and stability booklet which are intended for towing operations are also to be checked in order to investigate the ship's capability to withstand the effect of the transverse heeling moments induced by the combined action of the towline force and the thrust vector (self-tripping, see [2.2.5]), and induced by the hydrodynamic resistance of the hull (tow-tripping, see [2.2.6]).

### 2.2.5 Self-tripping (1/1/2021)

Self-tripping A tug may be considered as having sufficient stability to withstand the self-tripping heeling moment if the following condition is complied with (see Fig 1):

$$A \geq B$$

where:

- A : Area, in m<sup>2</sup>rad, contained between the righting arm and the heeling arm curves, measured from the heeling angle  $\theta_C$  to the heeling angle  $\theta_D$
- B : Area, in m<sup>2</sup>rad, contained between the heeling arm and the righting arm curves, measured from zero heel ( $\theta = 0$ ) to the heeling angle  $\theta_C$ .
- $\theta_C$  : Heeling angle of equilibrium, corresponding to the first intersection between heeling and righting arms curves.
- $\theta_D$  : Heeling angle, to be taken as the lesser of:
- heeling angle corresponding to the second intersection between heeling and righting arm curves
  - the angle of downflooding,

The self-tripping heeling arm curve is to be calculated as follows:

$$b_H = \sum b_{Hi}$$

where:

- $b_{Hi}$  : Heeling arm induced by one thruster or group of thrusters  $i$ , in m, calculated as follows:

$$b_{Hi} = \frac{T_{Bpi} \cdot c_i \cdot (h_i \cdot \cos\theta - r \cdot \sin\theta)}{9,81 \cdot \Delta}$$

- $T_{Bpi}$  : Amount of thrust, in kN, generated by one thruster or group of thrusters  $i$ . The sum of all the individual thrusts is to be equal to the design Bollard Pull, as defined in Ch 1, Sec 2, [2.1].
- $h_i$  : Vertical distance, in m, between the towing point (fairlead, staple, towing hook or

equivalent fitting) and the horizontal centreline of the propulsion unit or group of units  $i$ , as relevant for the considered towing situation

- $r$  : Transverse offset, in m, between the towing point and the ship's centerline. The towing point is the location where the towline force is applied to the ship (fairlead, staple, towing hook or equivalent fitting). When the towing point is not at the center line, the most unfavourable tow line position is to be considered.
- $c_i$  : Coefficient to be taken equal to:
- $c = 0,90 / (1 + d_i / L_{LL})$  for a group of 2 azimuthing thrusters, but is in no case to be taken less than:  
0,70 for ASD tugs towing over the stern and tractor tugs towing over the bow;  
0,50 for ASD tugs towing over the bow and tractor tugs towing over the stern.
  - $c = 1 / (1 + d_i / L_{LL})$  for a single azimuthing thruster
  - $c = 0,50$  for non-azimuth propulsion unit or group of units
- $\Delta$  : Loading condition displacement, in tons.
- $\theta$  : Angle of heel, in degrees
- $d_i$  : Longitudinal distance, in m, between the towing point (fairlead, staple, towing hook or equivalent fitting) and the vertical centreline of the propulsion unit or group of units  $i$ , as relevant for the considered towing situation
- $L_{LL}$  : Load line length, in m, defined in Pt B, Ch 1, Sec 2, [3.2].

**Figure 1 : Heeling and righting arms curves (1/1/2021)**

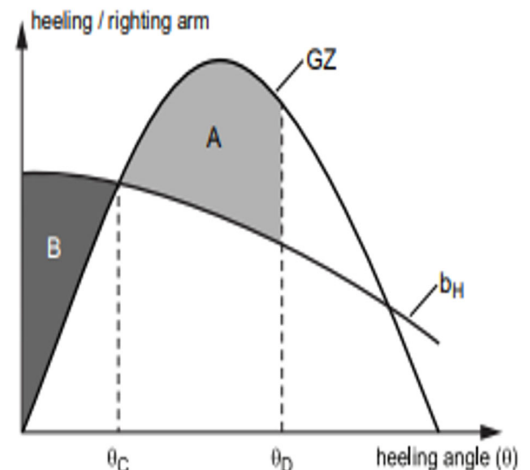

### 2.2.6 Tow-tripping (1/1/2021)

A tug may be considered as having sufficient stability to withstand the tow-tripping heeling moment if the first intersection between the righting arm curve and the tow-tripping heeling arm curve for tow-tripping occurs at an angle of heel less than the angle of downflooding. The tow-tripping heeling arm curve is to be calculated as follows:

$$b_H = \frac{C_1 \cdot C_2 \cdot \gamma \cdot V^2 \cdot A_p \cdot (h \cdot \cos\theta - r \cdot \sin\theta + C_3 \cdot T)}{19,62 \cdot \Delta}$$

Where:

$C_1$  : Lateral traction coefficient, taken equal to:

$$C_1 = 2,8 \cdot \left( \frac{L_s}{L_{LL}} - 0,1 \right)$$

without being taken lower than 0,1 and greater than 1.

$L_s$  : Longitudinal distance, in m, from the aft end of  $L_{LL}$  to the towing point

$C_2$  : Angle of heel correction for  $C_1$ , taken equal to:

$$C_2 = \left( \frac{\theta}{3 \cdot \theta_d} + 0,5 \right)$$

without being taken lower than 1.

$\theta_d$  : Angle to deck edge, in degree, taken equal to:

$$\theta_d = \text{atan}\left(\frac{2 \cdot f}{B}\right)$$

$f$  : Freeboard amidships, in m

$\gamma$  : Specific water density, in  $t/m^3$ , to be taken equal to 1,025

$V$  : Lateral velocity, in m/s, to be taken equal to 2,57 (5 Knots)

$A_p$  : Lateral projected area, in  $m^2$ , of the underwater hull

$C_3$  : Distance from the centre of  $A_p$  to the waterline as a fraction of the draught related to the heeling angle, taken equal to:

$$C_3 = \left( \frac{\theta}{\theta_d} \right) \cdot 0,26 + 0,3$$

without being taken lower than 0,5 and greater than 0,83.

$T$  : Loading condition draught, in m

$h$  : Vertical distance, in m, from the waterline to the towing point

### 2.2.7 Exemption (1/1/2021)

Tugs of any length with the navigation notation **sheltered area** may be exempted from complying with the requirement specified in [2.2.5] and [2.2.6], provided that the initial metacentric height GM, in m, corrected according to Pt B, Ch 3, Sec 2, [4.7], in the most severe condition is not less than the value obtained from the following formula:

$$GM = \frac{66 \cdot T \cdot H \cdot B}{f \cdot \Delta}$$

where:

$B$  : Ship's maximum breadth, in m

$f$  : Ship's freeboard, in mm, to be assumed not greater than 650 mm

$T, H, \Delta$  : Defined in [2.2.6].

## 2.3 Structure design principles

### 2.3.1 Bollards

For tugs equipped for side towing, the relevant bollards are to be effectively fixed on the deck in way of side transverses and deck beams or bulkheads.

### 2.3.2 Fenders

A strong fender for the protection of the tug's sides is to be fitted at deck level.

Alternatively, loose side fenders may be fitted, provided that they are supported by vertical ordinary stiffeners extending from the lightship waterline to the fenders themselves.

### 2.3.3 Floors

Floors are to be arranged with a welded face plate in the machinery space; elsewhere, floor flanging may be accepted as an alternative to the fitting of welded face plates.

### 2.3.4 Shaft tunnels

For tugs having small depth, the shaft tunnel may be omitted. In this case, access to the shaft line is to be given through the floor of the space above.

## 2.4 Hull scantlings

### 2.4.1 General

The net scantlings of plating, ordinary stiffeners and primary supporting members are to be in accordance with Part B, Chapter 7 or Part B, Chapter 8, as applicable, where the hull girder loads and the local loads are defined in Part B, Chapter 5 or Pt B, Ch 8, Sec 1, as applicable, to be calculated for T not less than 0,85 D.

### 2.4.2 Side plating thickness for tugs with L < 65 m

For tugs with L < 65 m, the net thickness of the side plating is to be increased by 1 mm with respect to that calculated according to Part B, Chapter 8, without being greater than that of the adjacent bottom plating calculated for the same panel dimensions.

## 2.5 Other structures

### 2.5.1 Machinery casings

Exposed machinery casings are to be not less than 900 mm in height, measured from the upper surface of the deck, and provided with weathertight means of closure.

In general, the longitudinal sides of the machinery casings are to be extended downwards by a deck girder to which the deck beams are to be connected.

Side ordinary stiffeners are to be connected to the deck. Their spacing is to be not greater than 0,75 m.

### 2.5.2 Emergency exits from machinery space

Emergency exits from the machinery space to the upper deck are to be located as high as possible above the waterline and in way of the ship's centreline, so that they may be used even at extreme angles of heel.

Escape hatch coaming heights are to be not less than 600 mm above the upper surface of the deck.

Escape hatch covers are to have hinges arranged athwartship and are to be capable of being opened and closed watertight from either side.

### 2.5.3 Height of hatchway coamings

The height of the hatchway coamings is to be not less than 300 mm. Hatch covers are to be fitted with efficient securing devices.

## 2.6 Rudder and bulwarks

### 2.6.1 Rudder

For tugs, the rudder stock diameter is to be increased by 5% with respect to that calculated according to Pt B, Ch 10, Sec 1, [4].

### 2.6.2 Bulwarks

The bulwarks are to be sloped inboard to avoid distortions likely to occur during contact. Their height may be reduced where required by operational necessities.

## 2.7 Equipment

### 2.7.1 Equipment number for tugs with the navigation notation “unrestricted navigation” (1/7/2024)

For tugs with the navigation notation **unrestricted navigation**, the equipment number EN is to be obtained from Pt B, Ch 10, Sec 4, [2.1.2] the following may be substituted for the term  $2hB$ :

$$2 \cdot \left( a \cdot B + \sum h_n \cdot b_n \right)$$

where  $a$ ,  $B$  and  $h_n$  are defined in Pt B, Ch 10, Sec 4, [2.1.2] and  $b_n$  is the breadth, in m, of the widest superstructure or deckhouse of each tier  $n$  having a breadth greater than  $B/4$ .

For tugs where the vertical extent of the superstructure is much greater than usual, the Society may require an increased equipment number EN.

### 2.7.2 Equipment number for tugs with the navigation notation coastal area or sheltered area

For tugs with the navigation notation **coastal area** or **sheltered area**, the equipment number EN is to be obtained from the following formula:

$$EN = 2,51 (L B D)^{2/3}$$

For tugs where the vertical extent of the superstructure is much greater than usual, the Society may require an increased equipment number EN.

For tugs with total block coefficient  $C_B$  less than 0,60, at a draught  $T$  equal to 0,85  $D$ , the equipment number EN is to be obtained from the following formulae:

$$EN = 1,76 (L B D)^{2/3}$$

For tugs where the vertical extent of the superstructure is much greater than usual, the Society may require an increased equipment number EN.

### 2.7.3 Anchors, chain cables and ropes (1/1/2017)

Tugs with notation **unrestricted navigation** or **summer navigation** with equipment number EN calculated according [2.7.1], are to be provided with equipment in anchors, chain cables and ropes obtained from Pt B, Ch 10, Sec 4.

Tugs with notation **unrestricted navigation** or **summer navigation** with equipment number EN calculated according g [2.7.1] equal to or less than 205, may reduce the number of anchor to one, and the mass of that anchor can be reduced to half of the mass indicated in Pt B, Ch 10, Sec 4, Tab 1. In the case only one anchor is adopted, the total length of anchor chain cable may be reduced to half of that indicated in Pt B, Ch 10, Sec 4, Tab 1. No reduction is foreseen for chain cable diameter.

Tugs with the navigation notation **coastal area** or **sheltered area** with equipment number EN calculated according [2.7.2], are to be provided with equipment in anchors, chain cables and ropes obtained from Tab 1 and Tab 2.

### 2.7.4 Additional equipment

Tugs are to be fitted with the additional equipment specified in Tab 3.

### 2.7.5 Tugs under 45 m in length intended for towing service only (1/7/2024)

For tugs under 45 m in length intended for towing service only, one anchor may be used onboard provided that the second anchor and its relevant chain cable holds readily available to be installed. In case of loss of anchor, the tug is to remain in port until replace anchor equipment is installed onboard.

## 2.8 Towing arrangements

### 2.8.1 General

In general, towing hooks and winches are to be arranged in way of the ship's centreline, in such a position as to minimise heeling moments in normal working conditions.

### 2.8.2 Definitions (1/7/2021)

- Emergency release system: refers to the mechanism and associated control arrangements that are used to release the load on the towline in a controlled manner under both normal and black out conditions
- Maximum design load: is the maximum load that can be held by the winch as defined by the manufacturer (the manufacturer's rating)
- Fleet angle: is the angle between the applied load (towline force) and the towline as it is wound onto the winch drum.

Figure 2 : Towline 'fleet angle' (1/7/2021)

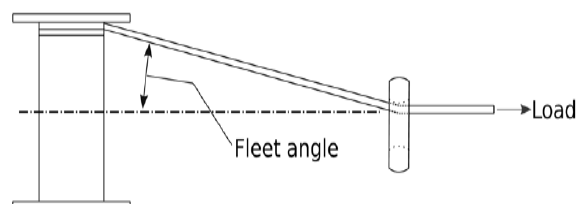



### 2.8.3 Hooks and winches (1/1/2020)

The hook and the winch materials are to comply with the applicable requirements of Part D.

The maximum towing force  $T$ , in kN, defined in [2.2.5], is to be specified in the structural arrangement plans of the hook and the winch.

The hooks and the winches are to be subjected to a static test, where the testing force  $C_T$  is to be not less than that obtained from Tab 4 as a function of  $T$ .

Winches may be equipped with a device for automatic adjustment of the tow.

All towing winches are to be fitted with an emergency release system.

**Table 1 : Equipment for tugs with the navigation notation coastal area or sheltered area (1/7/2013)**

Equipment number EN $A < EN \leq B$		Stockless anchors		Stud link chain cables for anchors		
A	B	N (1)	Mass per anchor, in kg	Total length, in m (2)	Diameter, in mm	
					mild steel	high strength steel
0	55	1	70	110,0	14,0 (3)	-
55	64	1	74	110,0	14,0 (3)	-
64	74	1	83	110,0	14,0 (3)	-
74	84	1	90	110,0	14,0 (3)	-
84	94	1	99	110,0	14,0	12,5
94	104	1	105	110,0	14,0	12,5
104	114	1	110	110,0	14,0	12,5
114	124	1	115	110,0	14,0	12,5
124	139	1	122	110,0	14,0	12,5
139	159	1	130	137,5	14,0	12,5
159	179	1	140	137,5	14,0	12,5
179	199	1	157	165,0	14,0	12,5
199	205	2	173	165,0	14,0	12,5
205	219	2	346	165,0	26,0	22,0
219	244	2	384	192,5	26,0	22,0
244	264	2	420	192,5	28,0	24,0
264	289	2	466	220,0	30,0	26,0
289	314	2	500	247,5	30,0	26,0
314	334	3	540	275,0	32,0	28,0
334	364	3	575	302,5	34,0	30,0
364	389	3	690	302,5	34,0	30,0
389	414	3	770	330,0	36,0	32,0
414	444	3	885	330,0	36,0	32,0
444	474	3	1000	357,5	38,0	34,0
474	504	3	1130	357,5	38,0	34,0
504	534	3	1270	385,0	40,0	34,0
534	569	3	1420	385,0	40,0	34,0
569	600		1540	440,0	42,0	36,0

(1) The third anchor is intended as a spare and is not required for the purpose of classification.  
(2) Where the total length required for chain cables is less than 220 m, one only of the two anchors may be linked with the chain cable and arranged in a hawse pipe. In this case, the second anchor is to be stowed such that it can be easily joined to the chain cable and dropped overboard in the event of loss of the first anchor.  
(3) These diameters are applicable to studless chain cables.

### 2.8.4 Hook quick-release device

The quick-release device is to be capable of being operated from a remote control device on the bridge, or as near as practicable, while the hook is under load. It is required that, in the case of a critical situation, the towline can be immediately released regardless of the angle of heel and the direction of the towline.

The quick-release device is to be tested both at maximum towing pull  $T$  and testing force  $C_T$ , defined above. The force necessary to open the hook under load is to be not greater than 150 N.

After installation on board, an unhooking trial under load is to be carried out by means of the above remote control device. This trial may be performed with a test load less than the maximum towing pull  $T$ .

**2.8.5 Winch towline release (1/1/2020)**

The in-board end of the towline is to be attached to the winch drum with a weak link or similar arrangement that is designed to release the towline at low load.

**2.8.6 Winch emergency release system requirements (1/7/2021)**

## a) Performance requirements

- 1) The emergency release system is to operate across the full range of towline load, fleet angle and ship heel angle under all normal and reasonably foreseeable abnormal conditions (these may include, but are not limited to, the following: vessel electrical failure, variable towline load (for example due to heavy weather), etc.).
- 2) The emergency release system shall be capable of operating with towline loads up to at least 100 per cent of the maximum design load.
- 3) The emergency release system is to function as quickly as is reasonably practicable and within a maximum of three seconds after activation.
- 4) The emergency release system is to allow the winch drum to rotate and the towline to pay out in a controlled manner such that, when the emergency release system is activated, there is sufficient resistance to rotation to avoid uncontrolled unwinding of the towline from the drum. Spinning (free, uncontrolled rotation) of the winch drum is to be avoided, as this could cause the towline to get stuck and disable the release function of the winch.
- 5) Once the emergency release is activated, the towline load required to rotate the winch drum is to be no greater than:
  - the lesser of five tonnes or five per cent of the maximum design load when two layers of towline are on the drum, or
  - 15 per cent of the maximum design load where it is demonstrated that this resistance to rotation does not exceed 25 per cent of the force that will result in listing sufficient for the immersion of the lowest unprotected opening.
- 6) Emergency release of the towline is to be possible in the event of a blackout. For this purpose, where additional sources of energy are required, such sources are to comply with [2.8.6] a) 7).
- 7) The sources of energy required by [2.8.6] a) 6) are to be sufficient to achieve the most onerous of the following conditions (as applicable):
  - sufficient for at least three attempts to release the towline (i.e. three activations of the emergency release system). Where the system provides energy for more than one winch it is to be sufficient for three activations of the most demanding winch connected to it.
  - Where the winch design is such that the drum release mechanism requires continuous application of power (e.g. where the brake is applied by spring tension and released using hydraulic or pneumatic power), sufficient power

is to be provided to operate the emergency release system (e.g. hold the brake open and allow release of the towline) in the event of a blackout for a minimum of five minutes. This may be reduced to the time required for the full length of the towline to feed off the winch drum at the load specified in [2.8.6] a) 5) if this is less than five minutes.

## b) Operational requirements

- 1) Emergency release operation must be possible from the bridge and from the winch control station on deck. The winch control station on deck is to be in a safe location. A position in close proximity to the winch is not regarded as "safe location", unless it is documented that the position is at least protected against towline break or winch failure.
- 2) The emergency release control is to be located close to an emergency stop button for winch operation, if provided, and shall be clearly identifiable, clearly visible, easily accessible and positioned to allow safe operability.
- 3) The emergency release function is to take priority over any emergency stop function. Activation of the winch emergency stop from any location is not to inhibit operation of the emergency release system from any location.
- 4) Emergency release system control buttons are to require positive action to cancel, the positive action may be made at a different control position from the one where the emergency release was activated. It must always be possible to cancel the emergency release from the bridge regardless of the activation location and without manual intervention on the working deck.
- 5) Controls for emergency use are to be protected against accidental use.
- 6) Indications are to be provided on the bridge for all power supply and/or pressure levels related to the normal operation of the emergency release system. Alarms are to activate automatically if any level falls outside of the limits within which the emergency release system is fully operational.
- 7) Wherever practicable, control of the emergency release system is to be provided by a hard-wired system, fully independent of programmable electronic systems.
- 8) Computer based systems that operate or may affect the control of emergency release systems are to meet the requirements for Category III systems as given in Pt C, Ch 2, Sec 3.
- 9) Components critical for the safe operation of the emergency release system are to be identified by the manufacturer.

**2.8.7 Connection with the hull structures**

The scantlings of the structures intended to connect the towing arrangements to the hull are to be in accordance with Part B, Chapter 7 or Part B, Chapter 8, as applicable,

where the load to be considered is the maximum towing pull T defined in [2.2.5].

**Table 2 : Mooring lines for tugs with the navigation notation coastal area or sheltered area (1/1/2022)**

Equipment number EN A < EN ≤ B		Mooring lines				
A	B	N	Breaking load, in kN	N	Ship Design Minimum Breaking Load, in kN	Length of each line, in m
0	55	1	24,5	1	59,8	110
55	64	1	24,5	1	66,7	110
65	74	1	24,5	1	73,5	110
75	84	1	24,5	1	80,4	110
85	94	1	30,4	1	86,3	110
95	104	1	34,3	1	91,2	110
105	114	1	38,2	1	95,1	110
115	124	1	43,2	1	99,0	110
125	139	1	49,0	1	104	110
140	159	1	58,8	1	111	120
160	179	1	68,6	1	119	120
180	199	1	78,4	1	127	120
200	219	1	88,2	1	136	120
220	244	1	98,0	1	145	120
245	264	1	108	1	154	120
265	289	1	108	1	163	120
290	314	1	108	1	172	130
315	334	1	108	1	174	130
335	364	1	108	2	174	130
365	389	1	108	2	174	130
390	414	1	108	2	174	140
415	444	1	108	2	174	140
445	474	1	108	2	174	140
475	504	1	108	2	174	140
505	534	1	108	2	174	150
535	569	1	108	2	174	150
570	600	1	108	2	174	160

**Table 3 : Additional equipment for tugs (1/7/2002)**

Arrangement or equipment	Navigation notation		
	Unrestricted navigation	Coastal area	Sheltered area
Fender	Requested	Requested	Requested
Towing hook or winch	Requested	Requested	Requested
Tow bar (1)	Requested	Requested	Not requested
No. of towlines of suitable diameter (2)	2	2	1
Length, in m, of towlines of suitable diameter (2)	200	150	100
No. of line throwing appliances (with 4 charges)	1	Not requested	Not requested
Crew accommodation spaces	Requested	Requested	Not requested
(1) The Society may not require the tow bar depending on the characteristics of the ship under consideration and where any obstructions on the deck area aft do not interfere with the towline during towing operations.			
(2) The suitability of the towline diameter is left to the judgement of the interested parties.			

**Table 4 : Testing force  $C_T$** 

Towing pull T, in kN	Testing force $C_T$ , in kN
$T < 400$	$2 T$
$400 \leq T \leq 1200$	$T + 400$
$T > 1200$	$1,33 T$

## 2.9 Test requirements

### 2.9.1 General (1/7/2021)

- All testing defined in [2.9] is to be witnessed by a Society surveyor
- For each emergency release system or type thereof, the performance requirements in [2.8.6] a) are to be verified either at the manufacturer's works or as part of the commissioning of the towing winch when it is installed on board. Where verification solely through testing is impracticable (e.g. due to health and safety), testing may be combined with inspection, analysis or demonstration in agreement with the Society.
- The performance capabilities, as well as instructions for operation, instructions of the emergency release system are to be documented by the manufacturer and made available on board the ship on which the winch has been installed.
- Instructions for surveys of the emergency release system are to be documented by the manufacturer, agreed by the Society and made available on board the ship on which the winch has been installed.
- Where necessary for conducting the annual and special surveys of the winch, adequately sized strong points are to be provided on deck.

### 2.9.2 Installation trials (1/1/2020)

- The full functionality of the emergency release system is to be tested as part of the shipboard commissioning trials to the satisfaction of the surveyor. Testing may be conducted either during a bollard pull test or by

applying the towline load against a strong point on the deck of the tug that is certified to the appropriate load.

- Where the performance of the winch in accordance with [2.8.6] a) has previously been verified, the load applied for the installation trials is to be at least the lesser of 30% of the maximum design load or 80% of vessel bollard pull.

## 2.10 Construction and testing

### 2.10.1 Bollard pull test (1/7/2012)

At the request of the interested parties, tugs may be subjected to a bollard pull test. The value of the bollard pull is indicated in a statement to be kept on board together with the ship documents.

The bollard pull test is to be carried out in the presence of a Surveyor of the Society according to the Rules for the certification of the bollard pull of tugs.

In the case of sister ships, the Society may assign the bollard pull on the basis of the results obtained from the tests carried out on the prototype ship.

## 2.11 Additional arrangements and equipment for tugs with additional service feature "rescue"

### 2.11.1 (1/7/2004)

Tugs with additional service feature "rescue" are to be provided with at least the arrangements and equipment indicated in [2.11.2].

### 2.11.2 (1/1/2017)

- a "RESCUE ZONE" area on each side of the ship's main deck where the relevant bulwark is lower than in the other part of the ship or provided with a gate in order to facilitate the embarkation of the shipwrecked persons. This zone is to be clearly identified by such wording written in at least 500 mm high/200 mm wide letters and side strips made in high intensity photo luminescent material

- b) nets or other equipment to facilitate the recovery of shipwrecked persons from the sea
- c) blankets (at least one for each person forming the maximum capacity of shipwrecked persons for which the ship is designed)
- d) cabins and beds in addition to those provided on board for the normal complement of crew (beds for at least 30% of the maximum capacity of shipwrecked persons for which the ship is designed)
- e) bathrooms and showers in addition to those provided on board for the normal complement of crew (bathrooms and showers for at least 1/6 of the maximum capacity of shipwrecked persons for which the ship is designed)
- f) sitting places (chairs, sofas and armchairs) in addition to those provided on board for the normal complement of crew (for 70% of the maximum capacity of shipwrecked persons for which the ship is designed)
- g) facilities and provisions for shipwrecked persons in addition to those necessary for the normal complement of crew (food rations for at least 300% of the maximum capacity of shipwrecked persons for which the ship is designed)
- h) first aid kits and medicines (for at least 100% of the maximum capacity of shipwrecked persons for which the ship is designed)
- i) a sick bay.

#### 2.11.3 (1/7/2010)

Relaxation from the requirements of [2.11.2] may be granted by the Society case-by-case on the basis of the ship operational area.

#### 2.11.4 (1/7/2010)

The maximum number of shipwrecked persons for which the ship is designed as well as the ship operational area, where [2.11.3] applies, are recorded in the Certificate of Classification of the ship.

The relevant arrangements and equipment are recorded in the ship's status.

#### 2.11.5 (1/1/2021)

An addendum to the trim and stability booklet is to be issued and submitted to the Society for approval. Such an addendum shall include:

- a) loading conditions pertaining to the maximum capacity of shipwrecked persons; and
- b) for each of the above loading conditions, checking of the criteria in Pt B, Ch 3, Sec 2, [2] and [3] (i.e. including weather criterion) and Ch 11, Sec 3, [1.1.3] and [1.1.4]. Such criteria are to be applied for any ship operational area.

### 2.12 Additional arrangements and equipment for tugs with additional service feature "standby vessel"

#### 2.12.1 (1/7/2016)

Tugs with additional service feature "standby vessel" are to be provided with at least the arrangements and equipment indicated in [2.12.2].

#### 2.12.2 (1/7/2016)

##### a) Rescue area

Ships with additional service feature **standby vessel** are to be provided, on each side, with a clearly marked rescue area having length not less than 8 m.

The rescue area is to comply with the following requirements:

- The ship's side in way of the rescue zone is to be free of any obstacle
- The ship's deck in way of the rescue area is to be so arranged as to protect personnel against injury
- The area is to be adequately fitted far from propellers and any ship side discharges up to 2 m below the waterline
- Each rescue area is to be provided with a scrambling net made of corrosion resistant and non-slip material

##### b) Rescue area lighting

Satisfactory lighting is to be provided along the rescue area.

A searchlight, able to provide an illumination level of 50 lux at a distance of 250 m, is to be available on each side and operated from the navigation bridge.

### 3 Additional requirements for salvage tugs

#### 3.1 General

##### 3.1.1 Application

The requirements of this Article apply to ships with the service notation **salvage tug** and specify the criteria these ships are to satisfy in addition to those in [2].

#### 3.2 Equipment

##### 3.2.1 Additional equipment

Ships with the service notation **salvage tug** are to be fitted with the additional equipment specified in Tab 5 in addition to that specified in Tab 3.

### 4 Additional requirements for escort tugs

#### 4.1 General

##### 4.1.1 Application

The requirements of this Article apply to ships with the service notation **escort tug** and specify the criteria these tugs are to satisfy in addition to those in [2].

##### 4.1.2 Characteristics of escort tugs (1/7/2005)

For classification purposes, the following characteristic is to be specified by the Designer:

- the maximum steering force  $T_Y$ , in kN, applied by the tug on the stern of the escorted ship, which is the transverse component of the maximum dynamic towing pull  $T$  with respect to the longitudinal axis of the escorted ship. This maximum force is generated at some

value of the angle  $\alpha$  between the line of pull and the direction of the escorted ship, see Fig 3. This force is to be calculated at speeds  $V$ , to be defined by the Designer and in general to be comprised between 8 and 10 knots. If the tug escort service is carried out within a certain speed range, the maximum steering forces  $T_V$  at the

minimum and maximum service speeds  $V_{MIN}$  e  $V_{MAX}$ , respectively, are to be calculated by the Designer.

$T_V$  is to be obtained on the basis of the results of full-scale tests (see [4.5]), to be carried out at speed  $V$  or, as applicable, at speeds  $V_{MIN}$  and  $V_{MAX}$ , defined above or alternatively may be evaluated by computer model simulation as indicated in [4.6.1].

**Table 5 : Additional equipment for salvage tugs**

Arrangement or equipment	Number of items
Fixed or movable drainage pumps having approximately the same capacity <b>(1) (2) (3)</b>	2 or more pumps of total capacity $\geq 400 \text{ m}^3/\text{h}$
Fire pumps each capable of throwing two simultaneous jets of water having a horizontal reach not less than 30 m <b>(4)</b>	2 pumps, each having a capacity $\geq 60 \text{ m}^3/\text{h}$
Breathing apparatuses for divers	2
Gas masks with filter	2
Cargo boom	1, with service load $\geq 1 \text{ t}$
Power operated winch capable of producing an adequate pull	1
Water stops to stop leaks of approximately 1 x 2 m	4
Complete set of equipment for flame cutting with at least 25 metres of flexible piping	1
Drain hoses	at least 20 m per pump
Fire hoses	10
Connections for fire main	at least 3
Power operated diver's compressor, with associated equipment <b>(5)</b>	1
Additional towline equipment, at least equal to that required for tugs in Tab 3	1
Lamps for underwater operation	2
Floodlight of power $\geq 500 \text{ W}$	1
Working lamps	2
Winding drums with wire ropes	see <b>(6)</b>
Electrical cables, each not less than 100 metres long and capable of supplying at least 50 kW	3
Tackles with lifting capacity of 1 t	2
Tackles with lifting capacity of 3 t	2
Radar with a range not less than 24 nautical miles	1
Echo-sounding device with a range of 100 m	1
Hydraulic jackets with lifting capacity of 10 t	2
Hydraulic jackets with lifting capacity of 20 t	2
Portable electrical drill with a set of twist bits having diameters up to 20 mm	1
<p><b>(1)</b> For each pump fitted on board, a suction strainer and, in the case of non self-priming pumps, a foot valve, are also to be provided.</p> <p><b>(2)</b> Where portable pumps are used, they are to be capable of effectively operating even with transverse and longitudinal inclinations up to 20°.</p> <p><b>(3)</b> These pumps are additional to the drain pumps intended for the drainage service of the ship.</p> <p><b>(4)</b> These pumps may be the same required for drainage purposes provided they have an adequate head.</p> <p><b>(5)</b> As an alternative, a compressor for recharging the oxygen tanks of divers may be provided together with two complete sets of equipment for divers.</p> <p><b>(6)</b> Winding drums fitted on board are to be capable of housing wire ropes of suitable size and length not normally less than 350 m.</p>	

Figure 3 : Typical escort configuration (1/7/2005)

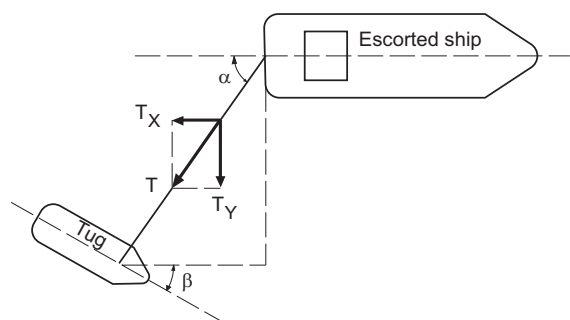

4.1.3 Documentation

In addition to the documents defined in Pt B, Ch 1, Sec 3, the following plans are to be submitted to the Society for information:

- towing arrangement plan, including towline components with relevant minimum breaking loads
- preliminary calculation of maximum steering forces  $T_y$  at speeds  $V$  or  $V_{MAX}$ , as applicable according to [4.1.2], including the propulsion force which is needed for equilibrating hydrodynamic forces acting on the tug and the towline pull
- preliminary stability calculation.

4.1.4 Propulsion forces (1/7/2005)

The hydrodynamic forces acting on the tug, the towline pull and the tug propulsion force are to be so designed that these forces are in equilibrium.

However, the engine is to ensure a sufficient thrust for manoeuvring the tug quickly for any angular position  $\beta$ , where  $\beta$  is defined in Fig 3.

4.1.5 Loss of propulsion

In the case of propulsion loss, the heeling moment due to the remaining forces is to lead to a safe equilibrium position of the tug with reduced heel.

4.2 Stability

4.2.1 Intact stability (1/7/2005)

A stability analysis of the tug is to be carried out taking into account the heeling moment caused by the forces acting on the tug, as shown in Fig 4.

The stability analysis is to consider:

- all potential attitudes of the escort tug relative to the direction of line pull,
- the maximum line pull,
- the resultant combination of heel and trim on the escort tug.

The stability analysis is to include the effects of fenders, skags, and other appendages on both the reserve buoyancy and the lateral resistance of the escort tug:

The two following intact stability criteria are to be complied with:

$A \geq 1,25 B$

$C \geq 1,4 D$

where:

A : Righting lever curve area, in m-rad, measured from the heeling angle  $\theta_c$  to a heeling angle of  $20^\circ$  (see Fig 5)

B : Heeling arm curve area, in m-rad, measured from the heeling angle  $\theta_c$  to a heeling angle of  $20^\circ$  (see Fig 5)

C : Righting lever curve area, in m-rad, measured from the angle  $0^\circ$  heel to the heeling angle  $\theta_D$  (see Fig 6)

D : Heeling arm curve area, in m-rad, measured from the angle  $0^\circ$  heel to the heeling angle  $\theta_D$  (see Fig 6)

$\theta_c$  : Heeling angle of equilibrium, corresponding to the first intersection between heeling and righting arms, to be obtained when the maximum steering force  $T_y$ , defined in [4.1.2], is applied from the tug

$\theta_D$  : Heeling angle, to be taken as the lesser of:

- the angle of downflooding
- $40^\circ$ .

The heeling arm curve is to be obtained from the full scale tests (see [4.5]), for the maximum steering force  $T_y$ .

Moreover, the heeling arm is to be assumed constant from the angle of equilibrium  $\theta_c$  to an angle equal to  $20^\circ$ .

Figure 4 : Dynamic stability components (1/7/2005)

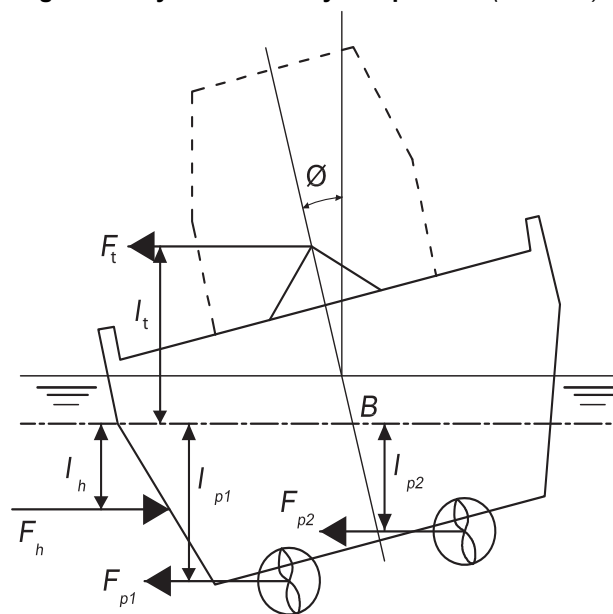

$F_t$  = Towline pull force, in t

$F_{p1}, F_{p2}$  = Propulsion thrust forces, in t

$F_h$  = Hull and appendage force, in t

$l_t$  = Towline pull force arm, in m

$l_{p1}, l_{p2}$  = Propulsion thrust forces arms, in m

$l_h$  = Hull and appendage force arm, in m

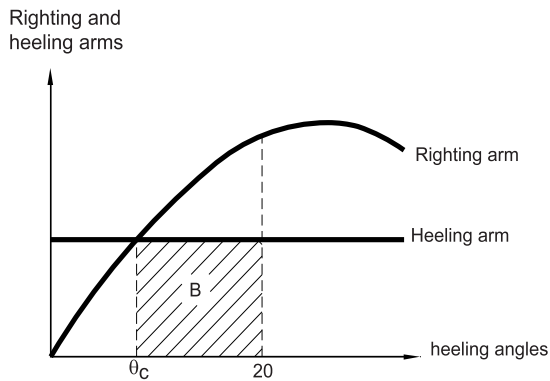
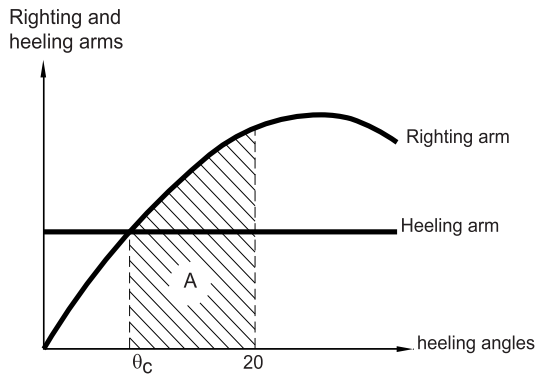
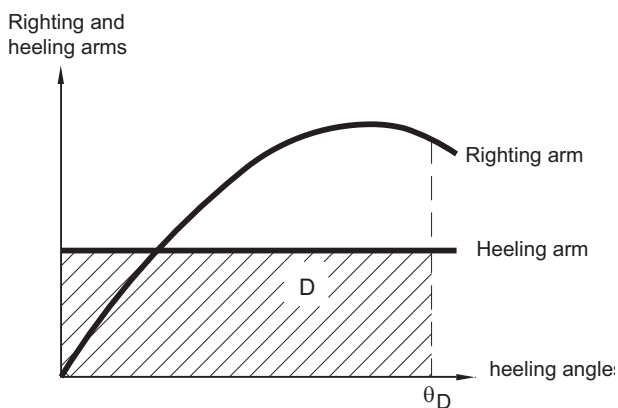
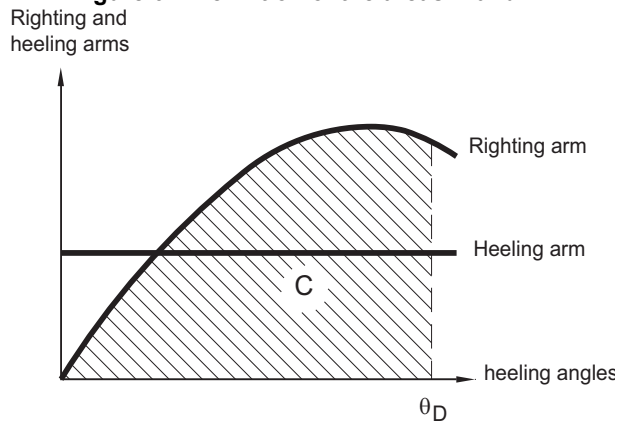
**Figure 5 : Definition of the areas A and B****Figure 6 : Definition of the areas C and D**

### 4.3 Structural design principles

#### 4.3.1 Hull shape

The hull shape is to be such as to provide adequate hydrodynamic lift and drag forces and to avoid excessive trim angles for large heeling angles.

#### 4.3.2 Bulwark

A bulwark is to be fitted all around the weather deck.

### 4.4 Equipment

#### 4.4.1 Towline breaking strength (1/1/2022)

The towline breaking strength is to be not less than 2,2 times the greater of the static bollard pull load and the maximum line pull.

#### 4.4.2 Towing winches (1/1/2021)

The towing winch is to be fitted with a system suitable to reduce the load in order to avoid overload due to dynamic oscillations of the towline. It is to be able to release the towline when the pull is greater than 50% of the towline breaking load.

Escort operations in conditions where dynamic oscillations of the towline are likely to occur may not be based on use of the brakes of the winch drum.

Escort operations performed by escort tugs in calm water conditions, such as in ports and sheltered (confined) waters, may be based on the use of the brakes of the winch drum. As a minimum, the winch brake holding load is to be equal to or greater than two times the maximum steady towline force, T.

### 4.5 Full-scale tests

#### 4.5.1 Testing

The following requirements apply to full scale tests to be carried out in order to obtain the values of the main characteristics of the tug defined in [4.1.2].

#### 4.5.2 Documentation to be submitted prior to testing

The following documentation is to be submitted to the Society for approval prior to testing:

- test speed of the tug; the speed is to be intended as relative speed with respect to the sea motions, therefore the effects of any possible current are to be taken into account
- main propulsion characteristics (power, maximum orientation angle of the rudder)
- preliminary calculation of the maximum steering force  $T_Y$  at the test speed
- calculation of the route deviation of the escorted ship (for the tests, the escorted ship is to be selected so that the route deviation induced by the tug is not too large)
- preliminary stability calculation in the above conditions
- towing arrangement plan, including the load cell and the specification of the breaking loads of the towline components
- documentation relevant to the bollard pull test (see [2.10.1]).



#### 4.5.3 Data to be collected during tests

During the tests, all data needed to define the characteristics of the tug are to be collected, e.g. the relative position ship-tug, their heading and speed, the towline length, the towline angle  $\alpha$  (see Fig 3), the maximum towing pull  $T$ , the ship rudder position, the heeling angle of the tug and any other parameter used in the preliminary calculation.

#### 4.6 Alternative to full-scale tests

##### 4.6.1 Maximum steering force (1/7/2005)

The maximum steering force  $T_Y$  that the tug applies on the assisted ship is to be evaluated by a computer model

programme that considers a quasi-steady solution, in which the horizontal forces and moments are balanced. The programme is also to consider the hydrodynamic forces on the escort tug's hull and underwater appendages, the forces acting on the rudder and the thrusts of the propellers.

#### 4.7 Inclinator

##### 4.7.1 (1/1/2021)

Escort tugs are to be equipped with a calibrated heeling angle measurement system (inclinator). The measured heeling angle is to be displayed in the wheelhouse next to the control desk or another appropriate location.

## SECTION 3 INTEGRATED TUG/BARGE COMBINATION

### Symbols

- $R_y$  : Minimum yield stress, in N/mm<sup>2</sup>, of the material, to be taken equal to 235/k N/mm<sup>2</sup>, unless otherwise specified
- $k$  : Material factor for steel, defined in Pt B, Ch 4, Sec 1, [2.3]
- $R_{eH}$  : Yield stress, in N/mm<sup>2</sup>, of the steel used, and not exceeding the lower of 0,7  $R_m$  and 450 N/mm<sup>2</sup>
- $R_m$  : Minimum ultimate tensile stress, in N/mm<sup>2</sup>, of the steel used.

### 1 General

#### 1.1 Application

##### 1.1.1 General

The requirements of this Section apply to the integrated tug/barge combinations constituted by:

- a tug, to which the additional service feature **barge combined** is assigned
- a barge, to which the additional service feature **tug combined** is assigned

and specify the criteria these combinations are to satisfy in addition to those in:

- Sec 2, [2], for the tug
- Ch 19, Sec 2, for the barge.

**1.1.2** When a series of barges may be operated in combination with a specific tug, the identification numbers of such barges are to be indicated in the tug class certificate.

**1.1.3** When a series of tugs may be operated in combination with a specific barge, the identification numbers of such tugs are to be indicated in the barge Certificate of Classification.

#### 1.2 Permanent connections

**1.2.1** An integrated tug/barge combination is connected with permanent connection if the tug and the barge cannot be disconnected in open sea. The connection is such that no relative motion between the tug and the barge is permitted.

#### 1.3 Removable connections

##### 1.3.1 General

An integrated tug/barge combination is connected with removable connection if the tug and the barge can be disconnected in open sea. The disconnecting procedure is to be performed safely by one man and is to take less than 5

min. After disconnection in open sea, the tug is to be arranged to tow the barge by hawser.

The procedure for disconnecting and reconnecting at sea the integrated tug/barge combination is to be made available for guidance to the Master.

##### 1.3.2 Types of removable connections

The removable connection is classed in the two following types:

- rigid connection, if no relative motion between the tug and the barge is permitted
- flexible connection, if relative motion between the tug and the barge is permitted (e.g. the tug is free to pitch with respect to the barge).

##### 1.3.3 Tug

The tug is to have the capability of separating from the barge and shifting to tow it by hawser.

### 2 General arrangement design

#### 2.1 Bulkhead arrangement

##### 2.1.1 Number and disposition of tug transverse watertight bulkheads

The tug is to be fitted with transverse watertight bulkheads according to Pt B, Ch 2, Sec 1.

##### 2.1.2 Number and disposition of barge transverse watertight bulkheads

In applying the criteria in Pt B, Ch 2, Sec 1, [3], the barge is to be fitted at least with an aftermost transverse watertight bulkhead located forward of the connection area and extended from side to side.

The cargo spaces are to be separated from the other spaces not used for cargo by watertight bulkheads.

##### 2.1.3 Barge collision bulkhead

The collision bulkhead of the barge is to be located at a distance, in m, from the fore end of L of not less than 0,05  $L_{LLC}$  or 10 m, whichever is the lesser, and not more than 0,08  $L_{LLB}$ , where:

$L_{LLC}$  : Ship's length, in m, measured between the aft and fore ends of L of the integrated tug/barge combination, taken at the fore and aft ends of the freeboard length

$L_{LLB}$  : Ship's length, in m, measured between the aft and fore ends of L of the barge considered as an individual ship, taken at the fore and aft ends of the freeboard length.

### 3 Integrated tug/barge combinations with permanent connection: stability, freeboard, design loads, hull scantlings and equipment

#### 3.1 Stability calculations

**3.1.1** The integrated tug/barge combination is to comply with the applicable intact and damage stability requirements in Part B, Chapter 3 considering the integrated tug/barge combination as a ship of the size of the combination.

#### 3.2 Freeboard calculation

**3.2.1** The freeboard is to be taken as the greatest of:

- the freeboard of the tug, considered as an individual ship
- the freeboard of the barge, considered as an individual ship
- the freeboard of the integrated tug/barge combination, considered as a ship of the size of the combination. For the freeboard calculation the barge is to be considered as being manned.

#### 3.3 Still water hull girder loads

**3.3.1** The still water hull girder loads and the forces transmitted through the connection are to be calculated for each loading condition considering the integrated tug/barge combination as a ship of the size of the combination.

#### 3.4 Wave hull girder loads

**3.4.1** The wave hull girder loads and the forces transmitted through the connection are to be calculated according to Pt B, Ch 5, Sec 2 considering the integrated tug/barge combination as a ship of the size of the combination.

##### 3.4.2 Direct calculation

When deemed necessary by the Society, the wave hull girder loads and the forces transmitted through the connection are to be obtained from a complete analysis of the integrated tug/barge combination motion and acceleration in irregular waves, unless such data are available from similar ships.

These loads are to be obtained as the most probable the integrated tug/barge combination, considered as a ship of the size of the combination, may experience during its operating life for a probability level of  $10^{-8}$ . For this calculation, the wave statistics relevant to the area of navigation and/or worst weather condition expressed by the navigation notation assigned to the integrated tug/barge combination are to be taken into account. For unrestricted navigation, the wave statistics relevant to the North Atlantic are to be taken into account.

When the difference between the tug and the barge depths is not considered negligible by the Society, its effects are to

be considered in evaluating the buoyancy force distributions and the corresponding hull girder loads on the tug structures immediately aft of the connection section, for the different wave encountering conditions.

#### 3.5 Still water local loads

**3.5.1** The still water local loads are to be calculated according to Pt B, Ch 5, Sec 5 for each loading condition and draught of the integrated tug/barge combination. The draught of the integrated tug/barge combination is to be taken not less than  $0,85 D$ , where  $D$  is the greater of the tug and the barge depths and not greater than the draught of the barge.

#### 3.6 Wave local loads

**3.6.1** The wave local loads are to be calculated according to Pt B, Ch 5, Sec 5, [2] considering the integrated tug/barge combination as a ship of the size of the combination. The draught of the integrated tug/barge combination is to be taken not less than  $0,85 D$ , where  $D$  is the greater of the tug and the barge depths and not greater than the draught of the barge.

#### 3.7 Hull girder strength

##### 3.7.1 Strength check

The longitudinal strength is to comply with Part B, Chapter 6, where the hull girder loads are those defined in [3.3] and [3.4].

##### 3.7.2 Loading manual

The loading manual is to include the (cargo and ballast) loading conditions of the integrated tug/barge combination at sea and in port conditions on the basis of which the approval of its hull structural scantlings is based.

The manual is to indicate the still water bending moment and shear force along the length of the integrated tug/barge combination as well as the permissible values at each hull section.

Information on loading and unloading sequences is to be provided for guidance to the Master.

#### 3.8 Scantlings of plating, ordinary stiffeners and primary supporting members

**3.8.1** The net scantlings of plating, ordinary stiffeners and primary supporting members are to be in accordance with Part B, Chapter 7 or Part B, Chapter 8, where the hull girder and local loads are those defined in [3.3] to [3.6].

In any case, the net scantlings of plating, ordinary stiffeners and primary supporting members of the tug and the barge are to be not less than those obtained according to Sec 2 and Ch 19, Sec 2 for the tug alone and the barge alone, respectively.

### 3.9 Equipment

**3.9.1** The equipment is to be in accordance with the requirements in both

- Sec 2, for the tug, and
- Ch 19, Sec 2, for the barge, considering the barge as a ship of the size of the integrated tug/barge combination.

## 4 Integrated tug/barge combination with removable connection: stability, freeboard, design loads, hull scantlings and equipment

### 4.1 Stability calculations

**4.1.1** The integrated tug/barge combination is to comply with the applicable intact stability requirement in Part B, Chapter 3, considering the integrated tug/barge combination as a ship of the size of the combination.

### 4.2 Freeboard calculation

**4.2.1** The freeboard is to be calculated for the tug and the barge considered as individual ships.

### 4.3 Still water hull girder loads

#### 4.3.1 General

The still water hull girder loads and the forces transmitted through the connection are to be calculated for each loading condition considering the integrated tug/barge combination as a ship of the size of the combination.

#### 4.3.2 Integrated tug/barge combination with removable flexible connection

For integrated tug/barge combinations with removable flexible connection, the effect of the degrees of freedom of the connection on the still water hull girder loads in the combination may be taken into account (e.g. free pitch of the tug with respect to the barge implies vertical bending moment equal to zero in the connection).

### 4.4 Wave hull girder loads

**4.4.1** The wave hull girder loads and the forces transmitted through the connection are to be calculated according to [3.4].

#### 4.4.2 Integrated tug/barge combination with removable flexible connection

For integrated tug/barge combinations with removable flexible connection, the effect of the degrees of freedom of the connection on the wave hull girder loads in the combination may be taken into account (e.g. free pitch of the tug with respect to the barge implies vertical bending moment equal to zero in the connection).

### 4.5 Still water local loads

**4.5.1** The still water local loads are to be calculated according to Pt B, Ch 5, Sec 5 for each loading condition and draught of the integrated tug/barge combination. The draught of the integrated tug/barge combination is to be taken not less than  $0,85 D$ , where  $D$  is the greater of the tug and the barge depths and not greater than the draught of the barge.

### 4.6 Wave local loads

**4.6.1** The wave local loads are to be calculated according to Pt B, Ch 5, Sec 5, [2] considering the integrated tug/barge combination as a ship of the size of the combination. The draught of the integrated tug/barge combination is to be taken not less than  $0,85 D$ , where  $D$  is the greater of the tug and the barge depths and not greater than the draught of the barge.

### 4.7 Hull girder strength

**4.7.1** The longitudinal strength is to comply with Part B, Chapter 6, where the hull girder loads are those defined in [4.3] and [4.4].

#### 4.7.2 Loading manual

The loading manual is to include the items specified in [3.7.2].

### 4.8 Scantlings of plating, ordinary stiffeners and primary supporting members

#### 4.8.1 Integrated tug/barge combinations with removable rigid connection

For integrated tug/barge combinations with removable rigid connection, the net scantlings of plating, ordinary stiffeners and primary supporting members are to be in accordance with Part B, Chapter 7 or Part B, Chapter 8, where the hull girder and local loads are those defined in [4.3] to [4.6].

In any case, the net scantlings of plating, ordinary stiffeners and primary supporting members of the tug and the barge are to be not less than those obtained according to Sec 2 and Ch 19, Sec 2 for the tug alone and the barge alone, respectively.

#### 4.8.2 Integrated tug/barge combinations with removable flexible connection

For integrated tug/barge combinations with removable flexible connection, the net scantlings of plating, ordinary stiffeners and primary supporting members of the tug and the barge are to be not less than those obtained according to Sec 2 and Ch 19, Sec 2 for the tug alone and the barge alone, respectively.

### 4.9 Equipment

**4.9.1** The equipment is to be in accordance with [3.9.1].

## 5 Connection

### 5.1 General

**5.1.1** The components of the connecting/disconnecting system are to be fitted on the tug.

Where the connecting system is located on a tug superstructure, this is to be checked according to Pt B, Ch 9, Sec 4. The efficiency of the structural connection between this superstructure and the underlying hull structures is to be ensured.

**5.1.2** The connecting system is to comply with the following requirements:

- it is to be permanently locked in position, at sea, with remote indication and control on the bridge
- it is to remain locked in the event of damage to the control system. A local control is to be provided for enabling the disconnection from the coupler machinery room.

### 5.2 Scantlings

#### 5.2.1 General

The bow of the tug and the stern of the barge are to be reinforced in order to withstand the connection forces.

The structure reinforcements are to be continued in aft and fore directions of the integrated tug/barge combination in order to transmit the connection forces to the hull structure of the tug and the barge.

#### 5.2.2 Calculation of stresses in the connection

The stresses in the connection are to be obtained by means of direct calculations, where the connection forces are to be obtained according to [3.3] and [3.4] or [4.3] and [4.4], as applicable, and the partial safety factors specified in Tab 1 are to be applied.

When calculating the stresses in the connection, pre-loading from locking devices, if any, is to be taken into account.

For notch type connections, the analysis of the barge wing walls is to take into account the effects of bending moment, shear force and torque.

**Table 1 : Partial safety factors**

Partial safety factors covering uncertainties regarding	Symbol	Partial safety factor value
Still water hull girder loads	$\gamma_{S1}$	1,00
Wave hull girder loads	$\gamma_{W1}$	1,15
Still water pressure	$\gamma_{S2}$	1,00
Wave pressure	$\gamma_{W2}$	1,20
Material	$\gamma_m$	1,02
Resistance	$\gamma_R$	1,02

#### 5.2.3 Shear check of the structural elements of the connection

The shear stresses in the structural elements of the connection are to comply with the following formulae:

$$\tau_E \leq \tau_{ALL}$$

$$\tau \leq 0,5 \frac{R_Y}{\gamma_R \gamma_m}$$

where:

$\tau$  : Shear stress, in N/mm<sup>2</sup>, to be obtained as a result of direct calculations

$\tau_{ALL}$  : Allowable shear stress, in N/mm<sup>2</sup>, to be taken equal to:

- $\tau_{ALL} = 0,5 \frac{R_Y}{\gamma_R \gamma_m}$  for structural steel plates

- $\tau_{ALL} = \frac{75}{\gamma_R \gamma_m k_1}$  for castings and forgings

$\gamma_R$  : Resistance partial safety factor, defined in Tab 1

$\gamma_m$  : Material partial safety factor, defined in Tab 1

$k_1$  : Material factor for castings and forgings, to be taken equal to:

$$k_1 = \left( \frac{235}{R_{eH}} \right)^{0,75}$$

#### 5.2.4 Yielding check of the structural elements of the connection

The Von Mises equivalent stresses in the structural elements of the connection are to comply with the following formula:

$$\sigma_E \leq \sigma_{ALL}$$

where:

$\sigma_E$  : Von Mises equivalent stress, in N/mm<sup>2</sup>, to be obtained as a result of direct calculations

$\sigma_{ALL}$  : Allowable stress, in N/mm<sup>2</sup>, to be taken equal to:

- $\sigma_{ALL} = \frac{R_Y}{\gamma_R \gamma_m}$  for structural steel plates

- $\sigma_{ALL} = \frac{150}{\gamma_R \gamma_m k_1}$  for castings and forgings

$\gamma_R$  : Resistance partial safety factor, defined in Tab 1

$\gamma_m$  : Material partial safety factor, defined in Tab 1

$k_1$  : Material factor for castings and forgings, defined in [5.2.3].

#### 5.2.5 Deflections

Deflections of the structural elements in the connection are to be obtained from direct calculations, to be carried out in accordance with [5.2.2] and submitted to the Society for review.

Deflection and pre-loading of the connection, if any, are to be considered in order to avoid hammering in the connection area.

## 6 Other structures

### 6.1 Tug fore part

#### 6.1.1 General

For integrated tug/barge combinations with permanent connection or removable rigid connection, the tug fore structure is to be aligned with the barge aft structure in way of the notch or the dock bottom.

### 6.1.2 Scantlings

The net scantlings of the fore part of the tug are to be in accordance with Part B, Chapter 7, considering the hull girder loads, the local loads and the connection forces defined in [3.3] to [3.6] for integrated tug/barge combinations with permanent connection or [4.3] to [4.6] for integrated tug/barge combinations with removable connection.

## 6.2 Tug aft part

### 6.2.1 Scantlings for integrated tug/barge combinations with permanent or removable rigid connections

The net scantlings of the aft part of the tug are to be in accordance with Pt B, Ch 9, Sec 2 considering this part as belonging to a ship of the size of the integrated tug/barge combination.

### 6.2.2 Scantlings for integrated tug/barge combinations with removable flexible connections

The net scantlings of the aft part of the tug are to be in accordance with Pt B, Ch 9, Sec 2 considering the tug as an individual ship.

## 6.3 Barge fore part

### 6.3.1 Scantlings for integrated tug/barge combinations with permanent or removable rigid connections

The net scantlings of the fore part of the barge are to be in accordance with Pt B, Ch 9, Sec 1 considering this part as belonging to a ship of the size of the integrated tug/barge combination.

### 6.3.2 Scantlings for integrated tug/barge combinations with removable flexible connections

The net scantlings of the fore part of the barge are to be in accordance with Pt B, Ch 9, Sec 1 considering the barge as an individual ship.

## 6.4 Barge aft part

### 6.4.1 General

For integrated tug/barge combinations with permanent connection or removable rigid connection, the barge aft structure is to be aligned with the tug fore structure in way of the notch or the dock bottom.

### 6.4.2 Scantlings

The net scantlings of the aft part of the barge are to be in accordance with Part B, Chapter 7, considering the hull girder loads, the local loads and the connection forces defined in [3.3] to [3.6] for integrated tug/barge combinations with permanent connection or [4.3] to [4.6] for integrated tug/barge combinations with removable connection.

## 7 Hull outfitting

### 7.1 Rudder and steering gear

**7.1.1** The tug rudder and steering gear are to be in accordance with Pt B, Ch 10, Sec 1 and Pt C, Ch 1, Sec 11, respectively, considering the maximum service speed (in ahead and astern condition) of the tug as an individual ship and the maximum service speed (in ahead and astern condition) of the integrated tug/barge combination.

The characteristics and performance of the rudder and the steering gear are to ensure the manoeuvrability of the integrated tug/barge combination.

## 8 Construction and testing

### 8.1 Test of the disconnection procedure of removable connection

**8.1.1** Tests are to be carried out in order to demonstrate the capability of the tug to be safely disconnected from the barge within 5 min by one man.

These tests may be performed in harbour. However, additional information is to be submitted to the Society in order to demonstrate the capability of the tug and the barge of being safely disconnected and reconnected at sea. The operating procedure, indicating the maximum or pre-fixed sea states, is to be made available for guidance to the Master, as indicated in [1.3.1].



Part E  
**Service Notations**

Chapter 15  
**SUPPLY VESSELS**

---

- SECTION 1      GENERAL**
- SECTION 2      HULL AND STABILITY**
- SECTION 3      MACHINERY AND CARGO SYSTEMS**





# SECTION 1 GENERAL

## 1 General

### 1.1 Application

**1.1.1** Ships complying with the requirements of this Chapter are eligible for the assignment of the service notation **supply vessel**, as defined in Pt A, Ch 1, Sec 2, [4.8.3].

**1.1.2** Ships dealt with in this Chapter are to comply with the requirements stipulated in Parts A, B, C and D, as applicable, and with the requirements of this Chapter, which are specific to supply vessels.

### 1.2 Summary table

**1.2.1** Tab 1 indicates, for ready reference, the Sections of this Chapter containing specific requirements applicable to supply vessels.

**Table 1 (1/1/2007)**

Main subject	Reference
Ship arrangement	(1)
Hull and stability	Sec 2
Machinery and cargo system	Sec 3
Electrical installations	(1)
Automation	(1)
Fire protection, detection and extinction	(1)
(1) No specific requirements for supply vessels are given in this Chapter.	

## SECTION 2

## HULL AND STABILITY

## Symbols

- $k$  : Material factor for steel, defined in Pt B, Ch 4, Sec 1, [2.3],
- $s$  : Length, in m, of the shorter side of the plate panel.
- $\alpha$  : Working fleet angle, in degrees, between the anchor handling wire rope in way of the last connection with the ship and a vertical axis, measured on the vertical plane  $\pi$  on which the anchor handling line lies (see Fig 1),
- $\beta$  : Working fleet angle, in degrees, measured horizontally between the vertical plane  $\pi$  on which the anchor handling line lies and the longitudinal vertical plane in way of the last connection with the ship (see Fig 1),
- $F_{AH}$  : Maximum allowed tension, in kN, in the steel wire rope used for anchor handling operation.

## 1 General

## 1.1 Definitions

## 1.1.1 Supply vessels

Supply vessels are, in general, single deck ships arranged with superstructures forward and a broad open deck aft intended for cargo.

Figure 1 (1/7/2011)

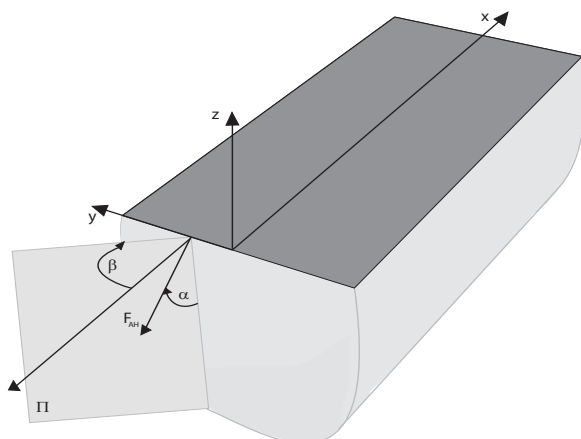

## 1.1.2 Additional service feature “oil product”

The additional service notation of supply vessels designed to carry oil products having any flashpoint in dedicated tanks is to be completed by the additional service feature **oil product**.

## 1.1.3 Additional service feature “chemical product”

The additional service notation of supply vessels designed to carry noxious products is to be completed by the additional service feature **chemical product**.

The products which may be carried are:

- hazardous and noxious liquids listed in Tab 1 and those other products which may be assigned to this list
- flammable liquid.

## 1.1.4 Additional service feature standby vessel (1/7/2003)

The additional service notation of supply vessels designed to provide rescue and standby services to offshore installations is to be completed by the additional service feature **standby vessel**.

## 1.1.5 Additional service feature "rescue" (1/7/2004)

The additional service notation of supply vessels is completed by the additional service feature **rescue** when they are specially equipped for the rescue of shipwrecked persons and for their accommodation.

## 1.1.6 Additional service feature "anchor handling" (1/7/2011)

The additional service notation of supply vessels is completed by the additional service feature **anchor handling** when they have visibility from the bridge and equipment specially designed for anchor handling operation.

## 1.1.7 Additional service feature "anchor handling stab" (1/7/2011)

The additional service notation of supply vessels is completed by the additional service feature **anchor handling stab** when they are specially equipped and designed for anchor handling operation and also fulfil specific stability requirements related to this service.

1.1.8 Additional service feature "heavycargo (X kN/m<sup>2</sup>)" (1/7/2022)

The additional service notation of supply vessels is completed by the additional service feature **heavycargo (X kN/m<sup>2</sup>)** when the weather deck intended to support heavy cargoes fulfills the appropriate structural rule requirements. The value X indicates the maximum allowable local pressure in kN/m<sup>2</sup>, which is to be greater than 10 kN/m<sup>2</sup>. The requirements for the assignment of this additional service feature are given in Pt B, Ch 5, Sec 6, [4.1.1] and Part B, Chapter 7 or Part B, Chapter 8, as applicable.

### 1.1.9 Additional service feature "heavyliquid (X t/m<sup>3</sup>)" (1/7/2022)

The additional service notation of supply vessels is completed by the additional service feature **heavyliquid (X t/m<sup>3</sup>)** when the ship is designed with specified cargo tanks strengthened to carry heavy liquids (i.e liquids having density greater than the one of the sea water) that fulfill the appropriate structural rule requirements. The value X indicates the maximum density in t/m<sup>3</sup> of the liquids that can be carried in the specified tanks 98% full. The requirements for the assignment of this additional service feature are given in Part B, Chapter 5 and Part B, Chapter 7 or Part B, Chapter 8, as applicable.

### 1.1.10 Additional service feature "Crew Transfer Vessel - CTV" (1/7/2022)

The additional service notation of supply vessels is completed by the additional service feature **Crew Transfer Vessel - CTV** when they are specially intended to transport technician and other personnel out to sites.

### 1.1.11 Additional service feature "Dive Support Vessel - DSV" (1/7/2022)

The additional service notation of supply vessels is completed by the additional service feature **Dive Support Vessel - DSV** when they are specially intended to support the offshore diving operation.

### 1.1.12 Additional service feature "Patrol and Guard Vessel" (1/7/2022)

The additional service notation of supply vessels is completed by the additional service feature **Patrol and Guard Vessel** when they are specially intended to patrol a coastal area or site for security, observation and defense.

### 1.1.13 Additional service feature "Seismic and Geotechnical Survey Vessel - SGSV" (1/7/2022)

The additional service notation of supply vessels is completed by the additional service feature **Seismic and Geotechnical Survey Vessel - SGSV** when they are specially intended for the purpose of research, seismic survey and mapping at seas.

### 1.1.14 Additional service feature "Windfarm Service Vessel - WSV" (1/7/2022)

The additional service notation of supply vessels is completed by the additional service feature **Windfarm Service Vessel - WSV** when they are specially intended to transport technician and other personnel to offshore wind farm and to support operations of wind farm maintenance and survey.

### 1.1.15 Integral tank

*Integral tank means a cargo containment envelope which forms part of the ship's hull and which may be stressed in the same manner and by the same loads which stress the contiguous hull structure and which is normally essential to the structural completeness of the ship's hull.*

### 1.1.16 Gas-dangerous spaces

Gas-dangerous spaces include:

- cargo tanks and cargo storage vessels
- cofferdams adjacent to cargo tanks and cargo storage vessels
- spaces where cargo handling pumps are located
- double bottoms or duct keels located under cargo tanks
- enclosed or partially enclosed spaces located directly above cargo tanks
- enclosed or partially enclosed spaces, located directly above pump rooms and cofferdams adjacent to cargo tanks and cargo storage vessels and which are not separated from such spaces by a gas-tight deck or effectively ventilated
- closed or partially closed spaces where piping, valves or other equipment for cargo handling are located
- zones on the weather deck located within a range of less than 10 m measured horizontally from the outlets of gas vents in cargo tanks and cargo storage vessels
- zones on the weather deck located above cargo tanks and cargo storage vessels within a height of 2,4 m above the deck or top of cargo storage vessels. Such zones are to be extended 3 m beyond the fore, aft and side ends of cargo tanks
- zones and partially enclosed spaces on the weather deck located within 3 metres of: hatches, any other openings in cargo tanks and cargo storage vessels, any cargo handling pumps which are not located in a space set aside for that purpose and the ends of cargo loading and unloading arrangements
- spaces for the storage of cargo hoses, if any.

## 2 General arrangement design

### 2.1 Compartment arrangement for all ships

#### 2.1.1 Location of cargo tanks and cargo storage vessels

All cargo tanks and cargo storage vessels are to be located aft of the collision bulkhead and forward of the aft peak.

#### 2.1.2 Independent portable tanks

Independent portable tanks, to be fitted on the weather deck, may be used as cargo storage vessels subject to the following conditions:

- the portable tanks are to be securely fastened to the hull structure
- in the zone on the weather deck where the portable tanks are arranged, a suitable possibly removable containment coaming is to be fitted such as to prevent any spillage and/or leakages from flowing to gas-safe areas
- a space is to be left between tanks and ship sides sufficient to allow easy passage of ship personnel and transfer of fire-fighting arrangements
- the cargo handling system serving portable tanks is to be such that liquid heads higher than those allowable for cargo tanks, if any, served by the same system cannot occur.

Provisions are to be made such that any portable tank is easily identifiable by means of markings or suitable plates.

## 2.2 Compartment arrangement for ships with additional service feature “oil product”

### 2.2.1 Length of cargo tanks

The length of each cargo tank may not exceed 10 metres or one of the values of Tab 3, as applicable, whichever is the greater.

### 2.2.2 Simultaneous carriage of dry cargoes and oil products

In general, the simultaneous carriage of dry cargoes and oil products with any flashpoint is not permitted.

Nevertheless, dry cargoes and oil products with a flashpoint of at least 43°C (closed cup test) may be simultaneously carried without special limitations provided that the room temperature in the spaces adjacent to cargo tanks, or where cargo storage vessels are installed, is at least 10°C below the flashpoint of the same oil products.

Where the above products are carried in storage vessels installed on the weather deck, adequate protection against accidental impact of the dry cargoes carried in the same area is to be provided.

**Table 1 : Hazardous and noxious permitted products (1/1/2009)**

Name	Category (1) (2)	Flammability
Drilling Brines, including Sodium Chloride Solution	Z	No
Drilling Brines, including Calcium Bromide Solution	Z	No
Drilling Brines, including Calcium Chloride Solution	Z	No
Calcium nitrate/Magnesium nitrate/Potassium chloride solution	Z	No
Calcium Nitrate Solution (50% or less)	Z	No
Drilling brines (containing zinc salts)	X	No
Potassium Formate Solution	Z	No
Potassium Chloride Solution	Z	No
Ethyl Alcohol	Z	Yes
Ethylene Glycol	Y	No
Ethylene Glycol monoalkyl ether	Y	Yes
Methyl Alcohol	Y	Yes
Acetic acid	Z	Yes
Formic acid	Y	Yes
Hydrochloric Acid	Z	No
Sulphuric Acid	Y	No
Toluene	Y	Yes
Xylene	Y	Yes
Liquid carbon dioxide	N/A	No
Liquid nitrogen	N/A	No
Noxious liquid, NF, (7) n.o.s. (trade name ..., contains ...) ST3, Cat. Y	Y	No
Noxious liquid, F, (8) n.o.s. (trade name ..., contains ...) ST3, Cat. Y	Y	Yes
Noxious liquid, NF, (9) n.o.s. (trade name ..., contains ...) ST3, Cat. Z	Z	No
Noxious liquid, F, (10) n.o.s. (trade name ..., contains ...) ST3, Cat. Z	Z	Yes
Noxious liquid, (11) n.o.s. (trade name ..., contains ...) Cat. Z	Z	No
Non-noxious liquid, (12) n.o.s. (trade name ..., contains ...) Cat. OS	N/A	No

(1) Product categories are defined in Tab 2

(2) N.A. means "not applicable"

**Table 2 : Hazardous and noxious product category (1/1/2009)**

Category	Definition
X	Noxious liquid substances which, if discharged into the sea from tank cleaning or deballasting operations, are deemed to present a major hazard to either marine resources or human health and, therefore, justify the prohibition of the discharge into the marine environment.
Y	Noxious liquid substances which, if discharged into the sea from tank cleaning or deballasting operations, are deemed to present a hazard to either marine resources or human health or cause harm to amenities or other legitimate uses of the sea and therefore justify a limitation on the quality and quantity of the discharge into the marine environment.
Z	Noxious liquid substances which, if discharged into the sea from tank cleaning or deballasting operations, are deemed to present a minor hazard to either marine resources or human health and therefore justify less stringent restrictions on the quality and quantity of the discharge into the marine environment.

**Table 3 : Length of cargo tanks**

Longitudinal Bulkhead	Type of Cargo Tank	$b_i/B$ (1)	Centreline Bulkhead	Length (m)
No bulkhead	-	-	-	$(0,5 \cdot b_i/B + 0,1) L$ (2)
Centreline bulkhead	-	-	-	$(0,25 \cdot b_i/B + 0,15) L$
Two or more bulkheads	Wing cargo tank	-	-	0,2 L
	Centre cargo tank	if $b_i/B > 1/5$	-	0,2 L
		if $b_i/B < 1/5$	NO	$(0,5 \cdot b_i/B + 0,1) L$
			YES	$(0,25 \cdot b_i/B + 0,15) L$
(1) Where $b_i$ is the minimum distance from the ship side to the outer longitudinal bulkhead of the tank in question measured inboard at right angles to the centreline at the level corresponding to the assigned summer freeboard.				
(2) Not to exceed 0,2 L.				

## 2.3 Compartment arrangement for ships with additional service feature “chemical product”

### 2.3.1 Location of cargo tanks and cargo storage vessels

Cargo tanks containing products as listed in [1.1.3] are to be located at least 760 mm measured inboard from the side of the vessel perpendicular to the centreline at the level of the summer load waterline.

### 2.3.2 Location of accommodation or service spaces and control stations

Accommodation or service spaces, or control stations may not be located within the cargo area.

### 2.3.3 Cargo tank extension

Cargo tanks may extend to the deck plating, provided dry cargo is not handled in that area. Where dry cargo is handled on the deck area above a cargo tank, the cargo tank may not extend to the deck plating unless a continuous, permanent deck sheathing of wood or other suitable material of appropriate thickness and construction is fitted to the satisfaction of the Society.

Cargoes may not be carried in either the fore or aft peak tanks.

### 2.3.4 Cargo segregation with fuel oils or other cargoes

Cargoes which react in a hazardous manner with other cargoes or fuel oils are to:

- be segregated from such other cargoes or fuel oils by means of a cofferdam, void space, cargo pump room, pump room, empty tank, or tank containing a mutually compatible cargo;
- have separate pumping and piping systems which may not pass through other cargo tanks containing such cargoes, unless encased in a tunnel; and
- have separate tank venting systems.

### 2.3.5 Cargo segregation with other spaces

Tanks containing cargo or residues of cargo listed in [1.1.3] are to be segregated from machinery spaces, shaft tunnels, if fitted, dry cargo spaces, accommodation and service spaces and from drinking water and stores for human consumption, by means of a cofferdam, void space, cargo pump room, empty tank, fuel oil tank, or other similar space. On-deck stowage of independent tanks or installation of independent tanks in otherwise empty hold spaces is to be considered as satisfactory.

### 2.3.6 Substances with a flashpoint exceeding 60°C

For pollution hazard only substances having a flashpoint exceeding 60°C (closed cup test), the Society may waive the arrangements referred to in [2.3.5] and [2.3.9] provided that the segregation requirements for accommodation spaces, drinking water and stores for human consumption

are observed. Additionally, [2.3.10] and [2.7.1] need not be applied.

### 2.3.7 Tank openings and connections

Except for the tank connections to cargo pump rooms, all tank openings and connections to the tank are to terminate above the weather deck and are to be located in the tops of the tanks. Where cofferdams are provided over integral tanks, small trunks may be used to penetrate the cofferdam.

### 2.3.8 Openings to accommodation, service and machinery spaces and control stations

- a) Unless they are spaced at least 7 m away from the cargo area containing flammable products, entrances, air inlets and openings to accommodation, service and machinery spaces and control stations may not face the cargo area. Doors to spaces not having access to accommodation, service and machinery spaces and control stations, such as cargo control stations and storerooms, may be permitted by the Society within the 7 m zone specified above, provided the boundaries of the spaces are insulated to A-60 standard. When arranged within the 7 m zone specified above, windows and sidescuttles facing the cargo area are to be of a fixed type. Such sidescuttles in the first tier on the main deck are to be fitted with inside covers of steel or equivalent material.
- b) In order to guard against the danger of hazardous vapours, due consideration is to be given to the location of air intakes and openings into accommodation, service and machinery spaces and control stations in relation to cargo piping and cargo vent systems.
- c) For pollution hazard only substances having a flashpoint exceeding 60°C, the arrangements referred to in a) and b) may be waived.

### 2.3.9 Openings for pipes

Cargo piping may not pass through any accommodation, service or machinery space other than cargo pump rooms or pump rooms.

### 2.3.10 Cofferdams

Where not bounded by bottom shell plating, fuel oil tanks, a cargo pump room or a pump room, the cargo tanks are to be surrounded by cofferdams. Tanks for other purposes (except fresh water and lubricating oils) may be accepted as cofferdams for these tanks.

### 2.3.11 Machinery space ventilators

Due regard is to be given to the position of machinery space ventilators. Preferably they are to be fitted in a position above the superstructure deck, or above an equivalent level if no superstructure deck is fitted.

## 2.4 Compartment arrangement for ships with additional service feature “standby vessel”

### 2.4.1 Survivor spaces (1/7/2003)

For ships with additional service feature **standby vessel**, a suitable closed accommodation space is to be provided for survivors.

The space is to be fitted with lighting, ventilation and adequate sanitary facilities, to be available exclusively for the survivors.

## 2.5 Access arrangement for all ships

### 2.5.1 Access to spaces below the freeboard deck

Access to the areas below the freeboard deck is, in general, to be provided from a position above the deck of a first tier superstructure.

As an alternative, indirect access may be provided from a space fitted with an outer door having a sill not less than 600 mm high and a self-closing, gas-tight inner door having a sill not less than 380 mm high.

### 2.5.2 Access to cargo pump rooms

Access to cargo pump rooms is only to be provided from an open position on the weather deck.

## 2.6 Access arrangement for ships with additional service feature “oil product”

### 2.6.1 Access to spaces within the cargo area

The access to spaces within the cargo area is to meet the requirements of Ch 7, Sec 2, [6.3].

### 2.6.2 Access to the gas-safe spaces

Gas-safe spaces such as accommodation, service, machinery and other similar spaces may not have any direct communication with gas-dangerous spaces defined in [1.1.16].

Nevertheless, access openings to gas-safe spaces below the weather deck, which are located less than 10 metres but not less than 3 metres from the outlets of gas vents in cargo tanks and cargo storage vessels, may be permitted where they are intended as emergency means of escape from normally attended spaces or as access to normally unattended spaces, provided that the relevant doors are kept permanently closed when the ship is not gas-freed.

Suitable warning plates are to be fixed in the proximity of such openings.

## 2.7 Access arrangement for ships with additional service feature “chemical product”

### 2.7.1 Access to spaces

For access to all spaces, the minimum spacing between cargo tank boundaries and adjacent ship's structures is to be 600 mm.

### 2.7.2 Access to the cargo deck

Hatches, doors, etc. which give access to the cargo deck are to be kept closed during navigation and are to comply with Pt B, Ch 2, Sec 1, [6.2.4].

### 2.7.3 Access to the machinery space

Access to the machinery space is, as far as practicable, to be arranged within the forecastle. Any access to the machinery space from the exposed cargo deck is to be provided with two weathertight closures. Access to spaces below the exposed cargo deck is preferably to be from a position within or above the superstructure deck.

## 2.8 Access arrangement for ships with additional service feature "standby vessel"

### 2.8.1 Rescue area (1/7/2003)

Ships with additional service feature **standby vessel** are to be provided, on each side, with a clearly marked rescue area having length not less than 8 m.

The rescue area is to comply with the following requirements:

- The ship's side in way of the rescue zone is to be free of any obstacle
- The ship's deck in way of the rescue area is to be so arranged as to protect personnel against injury
- The area is to be adequately fitted far from propellers and any ship side discharges up to 2 m below the waterline.
- Each rescue area is to be provided with a scrambling net made of corrosion resistant and non-slip material.

### 2.8.2 Rescue area lighting (1/7/2003)

Satisfactory lighting is to be provided along the rescue area.

A searchlight, able to provide an illumination level of 50 lux at a distance of 250 m, is to be available on each side and operated from the navigation bridge.

## 2.9 Additional arrangements and equipment for supply vessels with additional service feature "rescue"

### 2.9.1 (1/7/2004)

Supply vessels with additional service feature "rescue" are to be provided with at least the following arrangements and equipment indicated in [2.9.2].

### 2.9.2 (1/10/2021)

- a) a "RESCUE ZONE" area on each side of the ship's main deck where the relevant bulwark is lower than in the other part of the ship or provided with a gate in order to facilitate the embarkation of the shipwrecked persons. This zone is to be clearly identified by such wording written in at least 500 mm high/200 mm wide letters and side strips made in high intensity photo luminescent material
- b) nets or other equipment to facilitate the recovery of shipwrecked people from the sea

- c) blankets (at least one for each person forming the maximum capacity of shipwrecked people for which the ship is designed)
- d) cabins and beds in addition to those provided on board for the normal complement of crew (beds for at least 30% of the maximum capacity of shipwrecked people for which the ship is designed)
- e) bathrooms and showers in addition to those provided on board for the normal complement of crew (one bathroom and shower for every 50 persons or fraction of the maximum capacity of shipwrecked people for which the ship is designed)
- f) sitting places (chairs, sofas and armchairs) in addition to those provided on board for the normal complement of crew (for 100% of the maximum capacity of shipwrecked people for which the ship is designed)
- g) facilities and provisions for shipwrecked persons in addition to those necessary for the normal complement of crew (food rations for at least 300% of the maximum capacity of shipwrecked people for which the ship is designed)
- h) first aid kits and medicines (for at least 100% of the maximum capacity of shipwrecked people for which the ship is designed)
- i) a sick bay.

### 2.9.3 (1/10/2021)

Relaxation from the requirements of [2.9.2] may be granted by the Society case-by-case on the basis of the ship operational area, e.g. for ships operating in tropical and subequatorial climate areas, the requirement in [2.9.2] d) may be relaxed to beds for at least 10% of the maximum capacity of shipwrecked people for which the ship is designed and, for the remaining capacity of shipwrecked people, suitable thermal suites for the protection against cold and suitable sheltered areas by means of fixed or mobile shelter equipment (e.g. canopies).

### 2.9.4 (1/7/2013)

The maximum number of shipwrecked persons for which the ship is designed as well as the ship operational area, where [2.9.3] applies, are recorded in the Certificate of Classification of the ship.

The relevant arrangements and equipment are recorded in the ship's status.

### 2.9.5 (1/1/2021)

An addendum to the trim and stability booklet is to be issued and submitted to the Society for approval. Such an addendum shall include:

- a) loading conditions pertaining to the maximum capacity of shipwrecked persons; and
- b) for each of the above loading conditions, checking of the criteria in Pt B, Ch 3, Sec 2, [2] and [3] (i.e. including weather criterion) and Ch 11, Sec 3, [1.1.3] and [1.1.4]. Such criteria are to be applied for any ship operational area.



## 2.10 Additional requirements for supply vessels with additional service feature "anchor handling" and "anchor handling stab"

### 2.10.1 Visibility from the bridge deck (1/7/2011)

The visibility from the bridge deck is to be in compliance with the following requirements:

- the view of the sea surface from the working position at the workstation is to be not less than 600 m from the ship's stern (see Fig 2)
- the horizontal field of vision from the working position at the workstation shall extend over an arc of not less than the ship's stern breadth (see Fig 3)
- the anchor handling steel wire stoppers are to be visible from the working position at the workstation
- the spooling of the steel wire rope and the steel wire rope's guides/rollers are to be visible from the bridge
- for ships with the additional service feature anchor handling stab, the marking requested on the working bridge in [2.10.2] is to be visible from the bridge.

Figure 2 (1/7/2011)

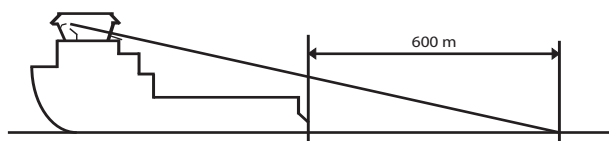
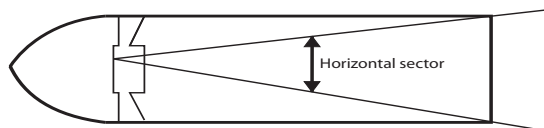

Figure 3 (1/7/2011)



### 2.10.2 Marking on the aft end of working bridge (only supply vessels with additional service feature "anchor handling stab") (1/7/2011)

For ships with the additional service feature anchor handling stab, adequate marking, which enables the Master to evaluate the angle  $\beta$ , is to be fitted on the aft end of the working bridge.

## 3 Stability

### 3.1 General

#### 3.1.1 Application (1/7/2002)

Every decked offshore supply vessel of 24 metres and over but not more than 100 metres in length is to comply with the provisions of [3.2]. The intact stability of a vessel of more than 100 metres in length is specified on a case-by-case basis.

#### 3.1.2 Relaxation (1/7/2002)

Relaxation in the requirements of [3.2] may be permitted by the Society for vessels engaged in near-coastal voyages pro-

vided the operating conditions are such as to render compliance with [3.2] unreasonable or unnecessary.

## 3.2 Intact stability for all ships

### 3.2.1 General stability criteria

The stability of the ship, for the loading conditions defined in Pt B, Ch 3, App 2, [1.2.1] and Pt B, Ch 3, App 2, [1.2.12] with the assumptions in [3.2.5], is to be in compliance with the requirements of Pt B, Ch 3, Sec 2, [2.1] or as an alternative with the requirements of [3.2.2]. The additional criteria of [3.2.3] are also to be complied with.

### 3.2.2 Alternative stability criteria

The following equivalent criteria are recommended where a vessel's characteristics render compliance with Pt B, Ch 3, Sec 2, [2.1] impracticable:

- The area, in  $m \cdot rad$ , under the curve of righting levers (GZ curve) may not be less than 0,070 up to an angle of  $15^\circ$  when the maximum righting lever (GZ) occurs at  $15^\circ$  and 0,055 up to an angle of  $30^\circ$  when the maximum righting lever (GZ) occurs at  $30^\circ$  or above. Where the maximum righting lever (GZ) occurs at angles of between  $15^\circ$  and  $30^\circ$ , the corresponding area "A", in  $m \cdot rad$ , under the righting lever curve is to be:

$$A = 0,055 + 0,001 \cdot (30^\circ - \theta_{max})$$

where  $\theta_{max}$  is the angle of heel, in degrees, at which the righting lever curve reaches its maximum.

- The area, in  $m \cdot rad$ , under the righting lever curve (GZ curve) between the angles of heel of  $30^\circ$  and  $40^\circ$ , or between  $30^\circ$  and  $\theta_f$  if this angle is less than  $40^\circ$ , may not be less than 0,03, where  $\theta_f$  is defined in Pt B, Ch 3, Sec 2, [2.1.2].
- The righting lever (GZ), in m, is to be at least 0,20 at an angle of heel equal to or greater than  $30^\circ$ .
- The maximum righting lever (GZ) is to occur at an angle of heel not less than  $15^\circ$ .
- The initial transverse metacentric height (GM), in m, may not be less than 0,15.

### 3.2.3 Additional criteria

A minimum freeboard at the stern of at least 0,005 L is to be maintained in all operating conditions.

### 3.2.4 Factors of influence

The stability criteria mentioned in [3.2.1] and [3.2.2] are minimum values; no maximum values are recommended. It is advisable to avoid excessive values, since these might lead to acceleration forces which could be prejudicial to the vessel, its complement, its equipment and the safe carriage of cargo.

Where anti-rolling devices are installed, the stability criteria indicated in [3.2.1] and [3.2.2] are to be maintained when the devices are in operation.

### 3.2.5 Assumptions for calculating loading conditions

If a vessel is fitted with cargo tanks, the fully loaded conditions of Pt B, Ch 3, App 2, [1.2.12] are to be modified, assuming first the cargo tanks full and then the cargo tanks empty.

If in any loading condition water ballast is necessary, additional diagrams are to be calculated, taking into account the water ballast, the quantity and disposition of which are to be stated in the stability information.

In all cases when deck cargo is carried, a realistic stowage weight is to be assumed and stated in the stability information, including the height of the cargo and its centre of gravity.

Where pipes are carried on deck, a quantity of trapped water equal to a certain percentage of the net volume of the pipe deck cargoes is to be assumed in and around the pipes. The net volume is to be taken as the internal volume of the pipes, plus the volume between the pipes. This percentage is 30 if the freeboard amidships is equal to or less than 0,015 L and 10 if the freeboard amidships is equal to or greater than 0,03 L. For intermediate values of the freeboard amidships, the percentage may be obtained by linear interpolation. In assessing the quantity of trapped water, the Society may take into account positive or negative sheer aft, actual trim and area of operation.

A vessel, when engaged in towing operations, may not carry deck cargo, except that a limited amount, properly secured, which would neither endanger the safe working of the crew nor impede the proper functioning of the towing equipment, may be accepted.

### 3.3 Intact stability for ships with additional service feature “oil product”

#### 3.3.1 Liquid transfer operations

Ships with particular internal subdivision may be subjected to lolling during liquid transfer operations such as loading, unloading or ballasting. In order to prevent the effect of lolling, the design of oil tankers of 5000 t deadweight and above is to be such that the following criteria are complied with:

- a) *The intact stability criteria reported in b) are to be complied with for the worst possible condition of loading and ballasting as defined in c), consistent with good operational practice, including the intermediate stages of liquid transfer operations. Under all conditions the ballast tanks are to be assumed slack.*
- b) *The initial metacentric height  $GM_{0\alpha}$ , in m, corrected for free surface measured at  $0^\circ$  heel, is to be not less than 0,15. For the purpose of calculating  $GM_{0\alpha}$ , liquid surface corrections are to be based on the appropriate upright free surface inertia moment.*
- c) *The vessel is to be loaded with:*
  - *all cargo tanks filled to a level corresponding to the maximum combined total of vertical moment of volume plus free surface inertia moment at  $0^\circ$  heel, for each individual tank,*
  - *cargo density corresponding to the available cargo deadweight at the displacement at which transverse KM reaches a minimum value,*
  - *full departure consumable,*
  - *1% of the total water ballast capacity. The maximum free surface moment is to be assumed in all ballast tanks.*

#### 3.3.2 Alternative requirements for liquid transfer operation

As an alternative to the requirements in [3.3.1], simple supplementary operational procedures are to be followed when the ship is carrying oil cargoes or during liquid transfer operations.

Simple supplementary operational procedures for liquid transfer operations means written procedures made available to the Master which:

- *are approved by the Society,*
- *indicate those cargo and ballast tanks which may, under any specific condition of liquid transfer and possible range of cargo densities, be slack and still allow the stability criteria to be met. The slack tanks may vary during the liquid transfer operations and be of any combination provided they satisfy the criteria,*
- *are to be readily understandable to the officer-in-charge of liquid transfer operations,*
- *provide for planned sequences of cargo/ballast transfer operations,*
- *allow comparisons of attained and required stability using stability performance criteria in graphical or tabular form,*
- *require no extensive mathematical calculations by the officer-in-charge,*
- *provide for corrective actions to be taken by the officer-in-charge in the event of departure from the recommended values and in case of emergency situations, and,*
- *are prominently displayed in the approved trim and stability booklet and at the cargo/ballast transfer control station and in any computer software by which stability calculations are performed.*

### 3.4 Intact stability for ships with additional service feature "anchor handling stab"

#### 3.4.1 Effects to be considered due to anchor handling steel wire rope tension (1/7/2011)

The additional trimming and heeling moment due to the maximum allowed tension in steel wire rope  $F_{AH}$  is to be taken into account in the ship stability calculations. In particular, the following criteria are to be fulfilled:

- the vertical component  $F_v$  of the force  $F_{AH}$  is to be applied at the upper edge of the stern roller (see Fig 4)
- the horizontal component  $F_h$  of the force  $F_{AH}$  is to be applied at the highest point between the upper edge of the stern roller and the edge of the winch where the steel wire rope is deployed
- for the purpose of calculating the heeling moments, the vertical and horizontal components  $F_v$  and  $F_h$  are to be applied at the outer edge of the stern roller (see Fig 4)
- the effect of the propeller is to be taken into account
- an adequate range of working fleet angles  $\alpha$  and  $\beta$  are to be considered in order to cover all possible operative conditions.

### 3.4.2 Stability criteria to be fulfilled during anchor handling operations (1/7/2011)

The maximum allowable KG curves are to be obtained taking into account that the static heeling angle calculated considering the effect of the anchor handling steel wire rope is to be less than the minimum of the following angles:

- heeling angle equivalent to a GZ value equal to 50% of  $GZ_{max}$
- the angle which results in water on the working deck when the deck is calculated as flat
- 15 degrees.

Figure 4 (1/7/2011)

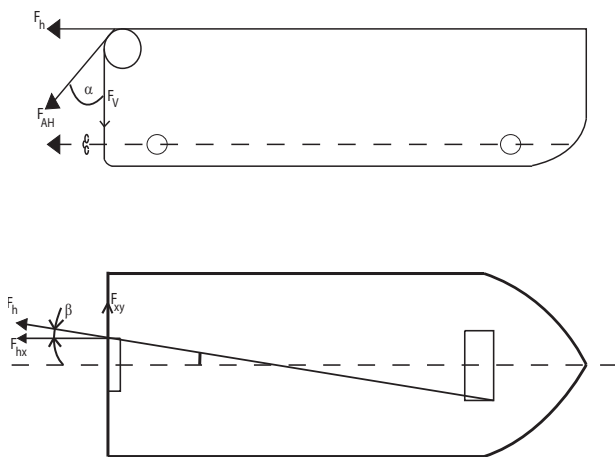

### 3.4.3 Information to be provided to the Master (1/7/2011)

A "stability operational manual for anchor handling operation" is to be provided on board for guidance to the Master, containing at least the following minimum information:

- curves indicating the maximum allowable KG for anchor handling operations as a function of the draft amidships, trim, maximum allowed tension  $F_{AH}$  in the steel wire rope used for anchor handling and the working fleet angles  $\alpha$  and  $\beta$ . The maximum KG curves are to be calculated applying the steel wire rope load as indicated in [3.4.2] and satisfying the criteria provided in [3.4.3]
- general arrangement drawing with description of the ship, propulsion and thruster configuration
- calculation example showing the use of KG curves
- compliance with the requirements listed in [3.4.3] for some typical operating loading conditions, considered by the Designer as being the most unfavourable combinations of tension in steel wire rope and working fleet angles  $\alpha$  and  $\beta$
- in general, the maximum allowable KG curves are to take into account also other stability criteria that the ship is required to satisfy. Where the maximum allowable KG curves indicated in the anchor handling operational manual take into account only the criteria provided in [3.4.3], a warning is to be given in the manual specifying that compliance of the actual loading

conditions with applicable requirements other than those in [3.4.3] is to be verified by the Master according to the information provided in the ship's loading manual

- maximum brake holding capacity of the winch
- maximum pull of the winch
- instructions for control of the maximum tension in the anchor handling steel wire rope.

## 4 Structure design principles

### 4.1 General

**4.1.1** For ships greater than 24 m in length, it is recommended that a double skin is provided to reinforce the protection of the main compartments in the event of contact with pontoons or platform piles.

### 4.2 Side structure exposed to bumping

#### 4.2.1 Longitudinally framed side

In the whole area where the side of the ship is exposed to bumping, distribution frames are to be provided at mid-span, consisting of an intercostal web of the same height as the ordinary stiffeners with a continuous face plate.

Within reinforced areas, scallop welding for all side ordinary stiffeners is forbidden.

#### 4.2.2 Transversely framed side

In the whole area where the side of the ship is exposed to bumping, a distribution stringer is to be fitted at mid-span, consisting of an intercostal web of the same height as the ordinary stiffeners with a continuous face plate.

Side frames are to be fitted with brackets at ends.

Within reinforced areas, scallop welding for all side ordinary stiffeners is forbidden.

#### 4.2.3 Fenders

Efficient fenders, adequately supported by structural members, are to be fitted on the side, including the forecastle, on the full length of the areas exposed to contact.

### 4.3 Deck structure

**4.3.1** Local reinforcements are to be fitted in way of specific areas which are subject to concentrated loads.

**4.3.2** Exposed decks carrying heavy cargoes or pipes are to provide protection and means of fastening for the cargo, e.g. inside bulwarks, guide members, lashing points, etc.

### 4.4 Structure of cement tanks and mud compartments

**4.4.1** Cargo tanks and hoppers intended to carry mud or cement are to be supported by structures which distribute the acting forces as evenly as possible on several primary supporting members.

## 5 Design loads

### 5.1 Dry uniform cargoes

#### 5.1.1 Still water and inertial pressures

The still water and inertial pressures transmitted to the structure of the upper deck intended to carry loads are to be obtained, in  $\text{kN/m}^2$ , as specified in Pt B, Ch 5, Sec 6, [4], where the value of  $p_s$  is to be taken not less than  $24 \text{ kN/m}^2$ .

## 6 Hull scantlings

### 6.1 Plating

#### 6.1.1 Minimum net thicknesses

The net thickness of the side and upper deck plating is to be not less than the values given in Tab 4.

**Table 4 : Minimum net thickness of the side and upper deck plating**

Plating	Minimum net thickness, in mm
Side below freeboard deck	The greater of: <ul style="list-style-type: none"> <li>• <math>2,1 + 0,031 L k^{0,5} + 4,5 s</math></li> <li>• <math>8 k^{0,5}</math></li> </ul>
Side between free-board deck and strength deck	The greater of: <ul style="list-style-type: none"> <li>• <math>2,1 + 0,013 L k^{0,5} + 4,5 s</math></li> <li>• <math>8 k^{0,5}</math></li> </ul>
Upper deck	7,0

#### 6.1.2 Strength deck plating

Within the cargo area, the net thickness of strength deck plating is to be increased by 1,5 mm with respect to that determined according to Pt B, Ch 7, Sec 1 or Pt B, Ch 8, Sec 3, as applicable.

### 6.2 Ordinary stiffeners

#### 6.2.1 Longitudinally framed side exposed to bumping

In the whole area where the side of the ship is exposed to bumping, the net section modulus of ordinary stiffeners is to be increased by 15% with respect to that determined according to Pt B, Ch 7, Sec 2 or Pt B, Ch 8, Sec 4, as applicable.

#### 6.2.2 Transversely framed side exposed to bumping

In the whole area where the side of the ship is exposed to bumping, the net section modulus of ordinary stiffeners, i.e. side, tweendeck and superstructure frames, is to be increased by 25% with respect to that determined according to Pt B, Ch 7, Sec 2 or Pt B, Ch 8, Sec 4, as applicable.

### 6.3 Primary supporting members

#### 6.3.1 Distribution stringers

The net section modulus of the distribution stringer required in [4.2.2] is to be at least twice that calculated in [6.2.2] for ordinary stiffeners.

#### 6.3.2 Cement tanks and mud compartments

The net scantlings of the primary supporting members of cement tanks and mud compartments are to be calculated taking into account high stresses resulting from vertical and horizontal accelerations due to rolling and pitching.

Secondary moments due to the tendency of materials to tip over are to be considered by the Society on a case-by-case basis.

## 7 Other structure

### 7.1 Aft part

#### 7.1.1 Rollers

At the transom, local reinforcements are to be fitted in way of rollers and other special equipment intended for cargo handling.

#### 7.1.2 Structures in way of rollers

The structures in way of the stern rollers and those of the adjacent deck are considered by the Society on a case-by-case basis, taking into account the relevant loads which are to be specified by the Designer.

#### 7.1.3 Propeller protection

It is recommended that devices should be fitted to protect the propellers from submerged cables.

### 7.2 Superstructures and deckhouses

#### 7.2.1 Forecastle

The forecastle length may not exceed 0,3 to 0,4 times the length L.

#### 7.2.2 Deckhouses

Due to their location at the forward end of the ship, deckhouses are to be reduced to essentials and special care is to be taken so that their scantlings and connections are sufficient to support wave loads.

#### 7.2.3 Minimum net thicknesses

The net thickness of forecastle aft end plating and of plating of deckhouses located on the forecastle deck is to be not less than the values given, in mm, in Tab 5.

**Table 5 : Minimum net thickness of forecastle aft end plating and plating of deckhouses located on the forecastle deck**

Plating	Minimum net thickness, in mm
Forecastle aft end	1,04 (5 + 0,01 L)
Front of deckhouses located on the forecastle deck	1,44 (4 + 0,01 L)
Sides of deckhouses located on the forecastle deck	1,31 (4 + 0,01 L)
Aft end of deckhouses located on the forecastle deck	1,22 (4 + 0,01 L)

**7.2.4 Ordinary stiffeners**

The net section modulus of ordinary stiffeners of the forecastle aft end and of deckhouses located on the forecastle deck is to be not less than the value obtained from Tab 6.

Ordinary stiffeners of the front of deckhouses located on the forecastle deck are to be fitted with brackets at their ends. Those of side and aft end bulkheads of deckhouses located on the forecastle deck are to be welded to decks at their ends.

**Table 6 : Ordinary stiffeners of the forecastle aft end and of deckhouses located on the forecastle deck**

Ordinary stiffeners	Net section modulus, in cm <sup>3</sup>
Forecastle aft end and front of deckhouses located on the forecastle deck	3 times the value calculated according to Pt B, Ch 9, Sec 4, [4].
Sides and aft end of deckhouses located on the forecastle deck	0,75 times that of the forecastle 'tweendeck frames.

**7.3 Arrangement for hull and superstructure openings**

**7.3.1 Sidescuttles and windows (1/7/2020)**

Sidescuttles and windows, with the relevant hinged and portable deadlight arrangement, are to be fitted according to Fig 5 and Pt B, Ch 9, Sec 9.

The strength of sidescuttles is to comply with Standard ISO 1751 as follows:

- Type A: in the shell plating, in the sides of superstructures and in the forward facing bulkhead of superstructures and deckhouses on weather deck as indicated in Fig 5
- Type B: in the after end of superstructures and in the sides and ends of deckhouses as indicated in Fig 5.

Portable deadlights and storm covers, where allowed according to Fig 5, are to be stowed adjacent to the windows for quick mounting.

Where portable deadlights are fitted externally, easy and safe access is to be provided for their mounting (e.g. gangway with rails).

At least two deadlights of wheelhouse windows are to be provided with means to provide a clear view.

The deadlights and storm covers are to comply with recognised national or international standards taking into account the glass thickness of the windows and sidescuttles to which they are attached.

The minimum thickness *t*, in mm, of glasses for sidescuttles and windows is to be obtained from the formula:

$$t = \frac{b}{S} \sqrt{p\beta}$$

where:

- b* : smaller dimension of the glass, in mm
- S* : safety factor obtained from Tab 7
- $\beta$  : adimensional factor
- p* : design sea pressure as given in Pt B, Ch 9, Sec 4, [2.2] to be assumed in any case not less than 6,5 KN/m<sup>2</sup>

$$\beta = 0,54 A_r - 0,078A_r^2 - 0,17 \text{ for } A_r < 3$$

$$\beta = 0,75 \text{ for } A_r \geq 3$$

$$A_r = a/b$$

*a* = length of the longer window side, in mm

Furthermore, the thickness of windows is not to be taken less than 10 mm. When laminated glass panes are used, to obtain the total thickness of the laminated panes a calculation for equivalent thickness according to a recognized international standard may be used by the designer.

**Table 7 : Safety factor S (1/7/2020)**

Window and sidescuttle location	2 <sup>nd</sup> tier	3 <sup>rd</sup> tier	4 <sup>th</sup> tier- and above	
Front or side	100	100	150	
Aft	100	150	200	

**Figure 5: Location windows and sidescuttles (1/7/2011)**

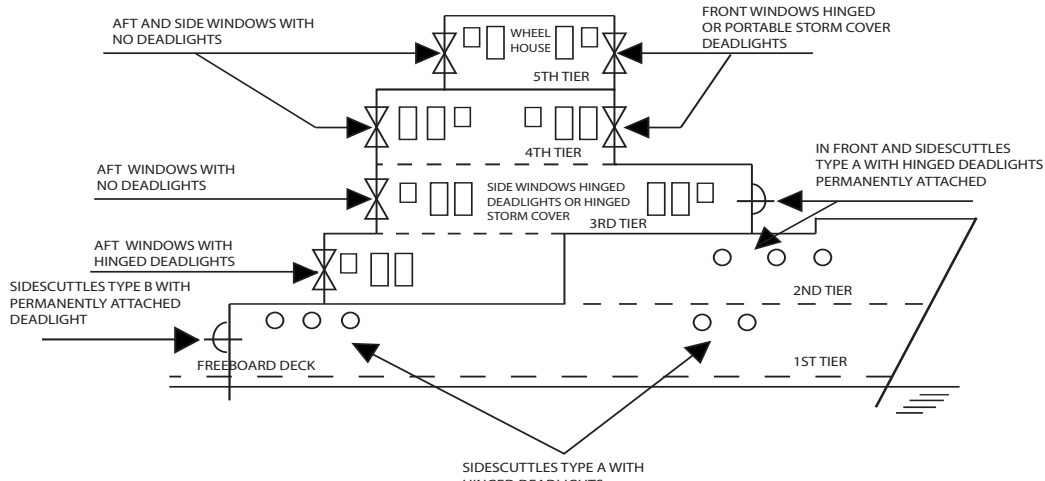

### 7.3.2 Sidescuttles of gas-safe spaces facing gas-dangerous spaces

Sidescuttles of gas-safe spaces facing gas-dangerous spaces, excluding those of non-opening type, are to be capable of ensuring an efficient gas-tight closure.

Warning plates are to be fitted on access doors to accommodation and service spaces facing the cargo area indicating that the doors and sidescuttles mentioned above are to be kept closed during cargo handling operations.

### 7.3.3 Freeing ports

The area of freeing ports is to be increased by 50% with respect to that determined according to Pt B, Ch 9, Sec 9, [5].

Shutters may not be fitted.

### 7.3.4 Freeing ports through box-bulwarks

Where box-bulwarks the upper level of which extends to the forecastle deck are fitted in way of the loading area, the freeing ports are to pass through these box-bulwarks, and their area is to be increased to take account of the height of the bulwarks.

### 7.3.5 Miscellaneous

Air pipes, ventilators, small hatchways, fans and control valves are to be located outside the loading area and protected from possible shifting of the deck cargo.

## 8 Hull outfitting

### 8.1 Rudders

#### 8.1.1 Rudder stock scantlings

The rudder stock diameter is to be increased by 5% with respect to that determined according to Pt B, Ch 10, Sec 1, [4].

### 8.2 Bulwarks

#### 8.2.1 Plating

In the case of a high bulwark, fitted with a face plate of large cross-sectional area, which contributes to the longitudinal strength, the net thickness of the plating contributing to the longitudinal strength is to be not less than the value obtained according to Pt B, Ch 7, Sec 1 or Pt B, Ch 8, Sec 3, as applicable.

#### 8.2.2 Stays

The bulwark stays are to be strongly built with an attachment to the deck reinforced to take account of accidental shifting of deck cargo (e.g. pipes).

### 8.2.3 Bulwark arrangement for ships with additional service feature standby vessel (1/7/2003)

For ships with additional service feature **standby vessel**, bulwarks or railings in way of the rescue zone are to be easy to open or remove, so as to enable direct access to deck.

### 8.3 Strength of rollers and their supporting structures for ships with additional service feature "anchor handling" and "anchor handling stab"

#### 8.3.1 Strength of rollers used for anchor handling operations and of their hull supporting structures (1/7/2011)

Stern rollers and all the rollers used for anchor handling operations, as well as their hull supporting structures, are to be designed to have a factor of safety of 3 with respect to the minimum yield strength of the material under a working load that is to be assumed not less than the greater of the maximum pull of the winch and the maximum brake holding capacity of the winch.

### 8.4 Equipment

#### 8.4.1 Chain cables for anchors (15/3/2009)

With the exception of ships with the additional class notation **DYNAPOS**, the required total length and the diameter of chain cables for bow anchors are to be those obtained from Pt B, Ch 10, Sec 4, Tab 1, for the EN range in the table, two rows below the one calculated according to Pt B, Ch 10, Sec 4, [2.1.2] or Pt B, Ch 10, Sec 4, [2.1.3], as applicable, for the ship under consideration.

#### 8.4.2 Mooring lines

The length of mooring lines is to be calculated according to Pt B, Ch 10, Sec 4, [3.5].

However, in the case of ships provided with devices enabling ample manoeuvring characteristics (e.g. ships provided with two or more propellers, athwartship thrust propellers, etc.), the length of mooring lines, in m, may be reduced to  $(L+20)$ .

#### 8.4.3 Chain locker

Chain lockers are to be arranged as gas-safe spaces. Hull penetrations for chain cables and mooring lines are to be arranged outside the gas-dangerous spaces specified in [1.1.16].

#### 8.4.4 Towline breaking load for ships with additional service feature standby vessel (1/7/2003)

For ships with additional service feature **standby vessel**, the towline breaking load is to be not less than  $0,04 P$ , in t, where  $P$  is the total power of the propulsion engines, in kW.

## **8.5 Arrangement of winches used for anchor handling operations for ships with additional service feature "anchor handling"**

### **8.5.1 Winch design and testing (1/7/2011)**

The winch materials are to be in compliance with the applicable requirements of Part D.

The maximum handling capacity of the anchor handling winch is to be specified in the structural arrangement of the winch.

The winches are to be subjected to a static test corresponding to their maximum handling capacity and to a static test considering the maximum brake winch holding capacity (with the brake in force).

### **8.5.2 Winch slip device (1/7/2011)**

Anchor handling winches are to be equipped with a suitable slip device, operable by local and remote control (if possible located on the bridge), allowing the rope to unwind when necessary.

### **8.5.3 Winch quick-release device (1/7/2011)**

The unhooking of the rope from the winch drum is to be possible by means of a suitable device or by using a rope whose terminal is not fixed to the drum.

### **8.5.4 Connection with hull structures (1/7/2011)**

The scantlings of the hull structures intended to connect the anchor handling winch to the hull are to be in accordance

with Part B, Chapter 7 or Part B, Chapter 8, as applicable, where the load to be considered is the greater of the maximum pull of the winch and the maximum brake holding capacity of the winch.

## **8.6 Arrangement of winches used for anchor handling operations for ships with additional service feature "anchor handling stab"**

### **8.6.1 Winch design (1/7/2011)**

The anchor handling winches are to be in accordance with the requirements from [8.5.1] to [8.5.4] and, in addition, they are to be fitted with a system suitable to adjust and keep constant the pull (the maximum pull for a precise loading condition is to be fixed by the Master according to the information provided in the operational loading manual).

This system is to be able to release the steel wire rope when the pull is greater than the adjusted one.

### **8.6.2 Winch monitoring systems (1/7/2011)**

The ship is to be fitted with a monitoring system on the bridge deck showing the following information:

- winch operation data (tension of steel wire rope, wire rope length, wire speed)
- winch control system status.

## SECTION 3

## MACHINERY AND CARGO SYSTEMS

### 1 General

#### 1.1 Application

##### 1.1.1 (1/1/2022)

This Section provides, for ships having the service notation supply vessel, requirements for:

- machinery systems
- cargo tanks and piping systems, in particular where the service features **oil product** or **chemical product** are assigned
- the calculation of the continuous duty pull of windlasses.

#### 1.2 Documents to be submitted

1.2.1 The documents listed in Tab 1 are to be submitted for approval.

### 2 Machinery systems

#### 2.1 Bilge system

##### 2.1.1 General

In supply vessels having the service feature **oil product** or **chemical product**, cargo pump rooms, duct keels below cargo tanks, hold spaces in which independent cargo tanks are installed and all gas-dangerous, dry cofferdams are to be served by an independent bilge pumping system entirely situated within the cargo area and fitted with pumps or

ejectors. No connection is permitted with the bilge system serving gas-safe spaces of the ship.

##### 2.1.2 Drainage of cargo pump rooms

Pumps and ejectors used for the drainage of cargo pump rooms are also to be capable of leading their delivery to a cargo tank, through a non-return valve and a connection at the tank top. Such provisions are intended to enable the drainage of such spaces in the event of cargo leakages without the risk of sea pollution.

##### 2.1.3 Specific requirement for acids

Spaces for acid storage tanks and acid pumping and piping are to be provided with drainage arrangements of corrosion-resistant materials.

#### 2.2 Other piping systems not intended for cargo

##### 2.2.1 Piping systems serving ballast tanks

Pumps, ballast lines, vent lines and other similar equipment serving permanent ballast tanks are to be independent of similar equipment serving cargo tanks.

##### 2.2.2 Piping systems serving spaces adjacent to cargo tanks

Where intended for ballast water, fuel oil, foam-forming liquids or dispersants, spaces adjacent to cargo tanks may be drained by pumps located in the machinery space, provided that the piping is directly connected to the associated pump and does not run through cargo tanks or cargo storage vessels.

**Table 1 : Documents to be submitted**

No.	A/I (1)	Document (2)
1	A	Plan of cargo handling systems intended for: <ul style="list-style-type: none"> <li>• powdery products such as cement, baryte, bentonite, etc.</li> <li>• liquid muds</li> <li>• oil products (3)</li> <li>• chemical products (4)</li> </ul>
2	A	Plan of gas vents in cargo tanks and cargo storage vessels (3) (4)
3	A	Plan of level gauging systems in cargo tanks and cargo storage vessels (3) (4)
4	A	Plan of the draining systems serving bilges in the cargo pump room and other gas-dangerous spaces (3) (4)
5	A	Plan of the pumping systems serving non-dry spaces adjacent to cargo tanks and cargo storage vessels (3) (4)
(1) A: To be submitted for approval in four copies I: To be submitted for information in duplicate (2) Diagrams are also to include, where applicable, the (local and remote) control and monitoring systems and automation systems. (3) for ships having the service feature <b>oil product</b> . (4) for ships having the service feature <b>chemical product</b> .		



No.	A/I (1)	Document (2)
6	A	Constructional plan of the automatic shut-off devices fitted to cargo hose couplings (3)
7	A	Plan of the cargo heating system
<p>(1) A: To be submitted for approval in four copies I: To be submitted for information in duplicate</p> <p>(2) Diagrams are also to include, where applicable, the (local and remote) control and monitoring systems and automation systems.</p> <p>(3) for ships having the service feature <b>oil product</b>.</p> <p>(4) for ships having the service feature <b>chemical product</b>.</p>		

### 2.2.3 Air pipes and sounding pipes of gas-dangerous cofferdams

- Gas-dangerous cofferdams are to be provided with air pipes led to the open and, where not accessible, also with sounding pipes.
- Outlets to the open of air pipes are to be fitted with easily removable metallic flameproof wire gauze.

## 2.3 Cargo heating systems

### 2.3.1 General

Heating media for cargo heating are to be compatible with the cargo itself and their temperature is not to exceed 220°C.

### 2.3.2 Use of steam

Where steam is used as a heating medium, the condensate from the cargo heating system is to be led to an observation tank located in an accessible, well-ventilated and well-lit position in the machinery space, well clear of boilers and other heat sources.

### 2.3.3 Use of cooling water

Cooling water from machinery in the engine room is not to be used for cargo heating. When it is intended to use the heat from such water, a secondary system outside the engine room is to be provided.

## 2.4 Exhaust pipes

2.4.1 In supply vessels having the service feature **oil product** or **chemical product**, the exhaust outlets from engines are to be fitted as high as practicable above the upper deck and are to be provided with spark arresters.

## 2.5 Steering gear

2.5.1 The steering gear is to be capable of putting the rudder from 35° on either side to 30° on the other side in not more than 20 seconds with the ship at its deepest seagoing draught and running ahead at maximum service speed.

## 3 Cargo systems - Requirements applicable to oil and chemical products

### 3.1 Cargo segregation

3.1.1 For cargo handling, a pumping and piping system entirely separate from other pumping and piping systems on

board is to be provided. Such systems are not to pass through any accommodation, service or machinery space other than cargo pump rooms.

## 3.2 Materials

3.2.1 Materials for construction of tanks, piping, fittings and pumps are to be in accordance with Ch 7, Sec 4, [3.3.2], Chapter 6 of the IBC Code, or Chapter 6 of the IGC Code, as applicable.

## 3.3 Installation of independent portable tanks

3.3.1 Independent portable tanks are to be fitted on the weather deck and are subject to the following conditions:

- the portable tanks are to be securely fastened to the hull structure to the satisfaction of the Society
- in the zone of the weather deck where the portable tanks are arranged, a suitable possibly removable containment coaming is to be fitted such as to prevent any spillages and flowing to gas-safe areas
- a space is to be left between tanks and ship sides sufficient to allow easy passage of ship personnel and transfer of fire-fighting arrangements.

## 4 Cargo systems of ships having the service feature “oil product”

### 4.1 Cargo pumping system, piping system and pump rooms

#### 4.1.1 General (1/1/2017)

- Where cargo handling pumps are installed in a space set aside for that purpose, such space is to comply with the applicable requirements for oil tankers. Refer to Ch 7, Sec 4 or Ch 7, Sec 5 for FP>60°C.
- For the construction, installation and operation of cargo pumps, the applicable requirements for oil tankers are to be complied with. Refer to Ch 7, Sec 4 or Ch 7, Sec 5 for FP>60°C.

#### 4.1.2 Piping system

- The cargo piping system is to be installed, except as stipulated in [4.1.3], within the cargo tank and cargo storage vessel area and is not to run through tanks, fuel

oil tanks and other compartments not belonging to the cargo system.

- b) Where necessary, cargo piping is to be provided with joints or expansion bends.
- c) Pipe lengths serving tanks are to be provided with shut-off valves operable from the weather deck.
- d) In order to prevent any generation of static electricity, the outlets of filling lines are to be led as low as possible in the tanks.

#### 4.1.3 Loading and unloading connections

- a) Pipe ends, valves and other fittings to which hoses for cargo loading and unloading are connected are to be of steel or other ductile material and are to be of solid construction and effectively secured.
- b) Connecting couplings for cargo hoses are to be fitted with devices which automatically shut off the cargo piping when the hose is disconnected and with means for quick-release of the hose, to be provided by the installation either of a coupling hydraulically controlled from outside the cargo area or of a weak link assembly which will break when subjected to a pre-determined pull.
- c) Where a pipe end to which hoses for cargo loading and unloading are connected is arranged outside the cargo tank area, the connection piping to such end is to be provided, in way of its connection to the manifold in the cargo tank area, with a blank spectacle flange or a spool piece, irrespective of the number and type of valves fitted in way of such connection. The space within a range of 3 metres from the above pipe end is to be considered gas-dangerous as far as electrical installations or other sources of ignition are concerned.

## 4.2 Cargo tanks and cargo storage vessels

### 4.2.1 Design and construction of portable tanks

- a) The cargo handling system serving portable tanks is to be such that liquid heads higher than those allowable for cargo tanks, if any, served by the same system cannot occur.
- b) Scantling of portable tanks is to be in compliance with the provisions of Pt C, Ch 1, App 4, except that the minimum thickness is not to be less than 5 mm.
- c) Provisions are to be made such that any portable tank is easily identifiable by means of markings or suitable plates.
- d) Portable tanks are to be provided with appropriate access hatches allowing the use of portable gas-freeing equipment.

### 4.2.2 Level gauging systems

- a) Each cargo tank or cargo storage vessel is to be fitted with at least one level gauging device of the closed type. Refer to Ch 7, Sec 4, [4.4.2].
- b) Sounding pipes may be accepted provided that they are so constructed and installed as to minimise the quantity of gas released during sounding operations. Such sounding pipes are not to be arranged within enclosed spaces.

### 4.2.3 Venting systems (1/1/2017)

Cargo tanks and cargo storage vessels are to be provided with gas venting systems entirely separate from any vent pipes serving other compartments. Such systems are to comply with the requirements for gas venting systems of cargo tanks of oil tankers. Refer to Ch 7, Sec 4, [4.2] or Ch 7, Sec 5, [4.2] for  $FP > 60^{\circ}\text{C}$ .

## 4.3 Prevention of pollution

### 4.3.1 (1/1/2017)

Residues of cargo oil, tank washing, other mixtures or ballast water containing cargo oil may be discharged into the sea provided that the discharge is in accordance with the relevant conditions as required under MARPOL 73/78, Annex I. Refer to Ch 7, Sec 4, [5] or Ch 7, Sec 5, [5] for  $FP > 60^{\circ}\text{C}$ .

## 5 Cargo systems of ships having the service feature “chemical product”

### 5.1 General

5.1.1 Unless otherwise stated, the special requirements for the cargo as referred to in Chapter 17 of the IBC Code or Chapter 19 of the IGC Code are applicable.

### 5.2 Cargo pumping and piping systems

#### 5.2.1 Segregation

Cargoes which react in a hazardous manner with other cargoes or fuel oils are to have separate pumping and piping systems not passing through other cargo tanks containing such cargoes, unless encased in a tunnel.

#### 5.2.2 Cargo transfer system

- a) The cargo transfer system is to comply with the requirements of Chapter 5 of the IBC Code.
- b) The remote shutdown devices for all cargo pumps and similar equipment, required by 5.6.1.3 of the IBC Code, are to be capable of being activated from a dedicated cargo control location which is manned at the time of cargo transfer and from at least one other location outside the cargo area and at a safe distance from it.
- c) In the case of transfer operations involving pressure in excess of 5 MPa gauge, arrangements for emergency depressurising and disconnection of the transfer hose are to be provided. The controls for activating emergency depressurisation and disconnection of the transfer hose are to meet the provisions of b) above.

#### 5.2.3 Special requirements for acids

Piping systems intended for acids are to comply with the following provisions:

- a) Flanges and other detachable connections are to be covered by spray shields.
- b) Portable shield covers protecting the connecting flanges of the loading manifold are to be provided. Drip trays of corrosion-resistant material are to be provided under loading manifolds for acids.

### 5.3 Cargo tanks

#### 5.3.1 General

- a) Cargo tanks are to be of the type required by the IBC Code or IGC Code, as applicable.
- b) Portable tanks meeting the requirements of Section 13 of the General Introduction to the International Maritime Dangerous Goods Code for the cargo concerned or other portable tanks specifically approved by the Society may be used, provided that they are properly located and secured to the vessel.

#### 5.3.2 Design, construction and testing of the tanks

- a) The design of the tanks is to comply with standards acceptable to the Society taking into account the carriage temperature and relative density of cargo. Due consideration is also to be given to dynamic forces and any vacuum pressure to which the tanks may be subjected.
- b) Integral and independent gravity tanks are to be constructed and tested according to recognised standards taking into account the carriage temperature and relative density of cargo.
- c) The greatest of the following design pressures (gauge) is to be used for determining scantlings of independent pressure tanks:
  - 0,07 MPa,
  - the vapour pressure of the cargo at 45°C,
  - the vapour pressure of the cargo at 15°C above the temperature at which it is normally carried, or
  - the pressure which occurs in the tank during the loading or unloading.
- d) Except for the tank connections to cargo pump rooms, all tank openings and connections to the tank are to terminate above the weather deck and are to be located in the tops of the tanks. Where cofferdams are provided over integral tanks, small trunks may be used to penetrate the cofferdam.

Note 1: This clause need not be applied for pollution hazard only substances having a flashpoint exceeding 60°C.

#### 5.3.3 Level gauging systems and level alarms

- a) Each cargo tank is to have a level gauging system and, where required by Chapter 17 of the IBC Code, a level alarm. Such devices are to comply with the relevant requirements of the IBC Code.

Note 1: Requirement 15.19.6 of the IBC Code for a visual and audible high-level alarm may be waived by the Society taking into account the cargo carriage arrangements and cargo loading procedures.

- b) Level gauging systems for process tanks on board well-stimulation vessels are to be to the satisfaction of the Society.

#### 5.3.4 Venting systems

- a) Cargoes which react in a hazardous manner with other cargoes or fuel oils are to have separate tank venting systems.
- b) Independent pressure tanks are to be fitted with pressure relief devices which are so designed as to direct the discharge away from personnel and have a set pressure and capacity which is in accordance with standards acceptable to the Society taking into account the design pressure referred to in [5.3.2].
- c) Cargo tank vent systems of integral or independent gravity tanks are to meet the requirements of the IBC Code, except that the height specified in IBC 8.2.2 may be reduced to 2 m.
- d) The location of cargo tank vent outlets for independent pressure tanks and for cargo tanks used to carry pollution hazard only substances with a flashpoint exceeding 60°C (closed cup test) is to be to the satisfaction of the Society.
- e) Cargo tank vent systems of portable tanks allowed under [5.3.1] are to be to the satisfaction of the Society, taking into account the provisions of [5.3.4].

### 5.4 Prevention of pollution

#### 5.4.1 Category X and Y substances (1/1/2007)

Discharge into the sea of category X and Y noxious liquid substances or ballast water, tank washing, or other residues or mixtures containing such substances is prohibited. Any discharges of residues containing noxious liquid substances are to be to reception facilities in port. As a consequence of this prohibition, the Society may waive the requirements for efficient stripping and underwater discharge arrangements in MARPOL 73/78, Annex II.

#### 5.4.2 Category Z substances (1/1/2007)

Residues of category Z substances, tank washings, other mixtures or ballast water containing such substances may be discharged into the sea provided that the discharge is in accordance with the relevant conditions as required under MARPOL 73/78, Annex II.

### 5.5 Personnel protection

#### 5.5.1 Decontamination showers and eyewashes

Except in the case of pollution hazard only substances, a suitably marked decontamination shower and eyewash are to be available on deck in a convenient location. The shower and eyewash are to be operable in all ambient conditions.

#### 5.5.2 Protective and safety equipment

Protective and safety equipment is to be kept on board in suitable locations as required in Chapter 14 of the IBC Code or the IGC Code for products to be carried.

## 6 Requirements for windlass

### 6.1 Assumptions for the calculation of the continuous duty pull

#### 6.1.1 (1/1/2022)

The calculation of the continuous duty pull  $P_C$  that the windlass unit prime mover is to be able to supply is based on the following assumptions:

- ordinary stockless anchors
- wind force equal to 6 on Beaufort Scale
- water current velocity 3 knots
- anchorage depth 100 m
- $P_C$  includes the influences of buoyancy and hawse pipe efficiency; the latter is assumed equal to 70%
- the anchor masses assumed are those defined in Pt D, Ch 4, Sec 1, excluding tolerances
- only one anchor is assumed to be raised at a time.

Owing to the buoyancy, the chain masses assumed are smaller than those defined in Pt D, Ch 4, Sec 1, and are obtained, per unit length of the chain cable, in kg/m, from the following formula:

$$m_L = 0,0218 d^2$$

where  $d$  is the chain cable diameter, in mm.

### 6.2 Calculation of the continuous duty pull

#### 6.2.1 (1/1/2022)

The calculation of the continuous duty pull  $P_C$  is to be in accordance to Pt C, Ch 1, Sec 15.