

Rules for the Classification of Ships

Effective from 1 July 2024

Part C

Machinery, Systems and Fire Protection



GENERAL CONDITIONS

Definitions:

Administration means the Government of the State whose flag the ship is entitled to fly or under whose authority the ship is authorized to operate in the specific case.

“IACS” means the International Association of Classification Societies.

“Interested Party” means the party, other than the Society, having an interest in or responsibility for the Ship, product, plant or system subject to classification or certification (such as the owner of the Ship and his representatives, the shipbuilder, the engine builder or the supplier of parts to be tested) who requests the Services or on whose behalf the Services are requested.

“Owner” means the registered owner, the shipowner, the manager or any other party with the responsibility, legally or contractually, to keep the ship seaworthy or in service, having particular regard to the provisions relating to the maintenance of class laid down in Part A, Chapter 2 of the Rules for the Classification of Ships or in the corresponding rules indicated in the Specific Rules.

“Rules” in these General Conditions means the documents below issued by the Society:

- (i) Rules for the Classification of Ships or other special units.
- (ii) Complementary Rules containing the requirements for product, plant, system and other certification or containing the requirements for the assignment of additional class notations;
- (iii) Rules for the application of statutory rules, containing the rules to perform the duties delegated by Administrations.
- (iv) Guides to carry out particular activities connected with Services;
- (v) Any other technical document, for example, rule variations or interpretations.

“Services” means the activities described in paragraph 1 below, rendered by the Society upon request made by or on behalf of the Interested Party.

“Ship” means ships, boats, craft and other special units, for example, offshore structures, floating units and underwater craft.

“Society” or **“TASNEEF”** means TASNEEF Maritime

“Surveyor” means technical staff acting on behalf of the Society in performing the Services.

“Force Majeure” means damage to the ship; unforeseen inability of the Society to attend the ship due to government restrictions on right of access or movement of personnel; unforeseeable delays in port or inability to discharge cargo due to unusually lengthy periods of severe weather, strikes or civil strife; acts of war; or other force majeure.

1. Society Roles

1.1. The purpose of the Society is, among others, the classification and certification of ships and the certification of their parts and components. In particular, the Society:

- (i) sets forth and develops Rules.
- (ii) publishes the Register of Ships.
- (iii) Issues certificates, statements and reports based on its survey activities.

1.2. The Society also takes part in the implementation of national and international rules and standards as delegated by various Governments.

1.3. The Society carries out technical assistance activities on request and provides special services outside the scope of classification, which is regulated by these general conditions unless expressly excluded in the particular contract.





2. Rule Development, Implementation and Selection of Surveyor

2.1. The Rules developed by the Society reflect the level of its technical knowledge at the time they are published therefore, the Society, although also committed through its research and development services to continuous updating of the Rules, does not guarantee the Rules meet state-of-the-art science and technology at the time of publication or that they meet the Society's or others' subsequent technical developments.

2.2. The Interested Party is required to know the Rules based on which the Services are provided. With particular reference to Classification Services, special attention is to be given to the Rules concerning class suspension, withdrawal and reinstatement. In case of doubt or inaccuracy, the Interested Party is to promptly contact the Society for clarification. The Rules for Classification of Ships are published on the Society's website: www.tasneef.ae.

2.3. Society exercises due care and skill:

(i) In the selection of its Surveyors

(ii) In the performance of its Services, taking into account the level of its technical knowledge at the time the Services are performed.

2.4. Surveys conducted by the Society include, but are not limited to, visual inspection and non-destructive testing. Unless otherwise required, surveys are conducted through sampling techniques and do not consist of comprehensive verification or monitoring of the Ship or the items subject to certification. The surveys and checks made by the Society on board ship do not necessarily require the constant and continuous presence of the Surveyor. The Society may also commission laboratory testing, underwater inspection and other checks carried out by and under the responsibility of qualified service suppliers. Survey practices and procedures are selected by the Society based on its experience and knowledge and according to generally accepted technical standards in the sector.

3. Class Report & Interested Parties Obligation

3.1. The class assigned to a Ship, like the reports, statements, certificates or any other document or information issued by the Society, reflects the opinion of the Society concerning compliance, at the time the Service is provided, of the Ship or product subject to certification, with the applicable Rules (given the intended use and within the relevant time frame). The Society is under no obligation to make statements or provide information about elements or facts which are not part of the specific scope of the Service requested by the Interested Party or on its behalf.

3.2. No report, statement, notation on a plan, review, Certificate of Classification, document or information issued or given as part of the Services provided by the Society shall have any legal effect or implication other than a representation that, on the basis of the checks made by the Society, the Ship, structure, materials, equipment, machinery or any other item covered by such document or information meet the Rules. Any such document is issued solely for the use of the Society, its committees and clients or other duly authorized bodies and no other purpose. Therefore, the Society cannot be held liable for any act made or document issued by other parties based on the statements or information given by the Society. The validity, application, meaning and interpretation of a Certificate of Classification, or any other document or information issued by the Society in connection with its Services, is governed by the Rules of the Society, which is the sole subject entitled to make such interpretation. Any disagreement on technical matters between the Interested Party and the Surveyor in the carrying out of his functions shall be raised in writing as soon as possible with the Society, which will settle any divergence of opinion or dispute.

3.3. The classification of a Ship or the issuance of a certificate or other document connected with classification or certification and in general with the performance of Services by the Society shall have the validity conferred upon it by the Rules of the Society at the time of the assignment of class or issuance of the certificate; in no case shall it amount to a statement or warranty of seaworthiness, structural integrity, quality or fitness for a particular purpose or service of any Ship, structure, material, equipment or machinery inspected or tested by the Society.

3.4. Any document issued by the Society about its activities reflects the condition of the Ship or the subject of certification or other activity at the time of the check.

3.5. The Rules, surveys and activities performed by the Society, reports, certificates and other documents issued by the Society are in no way intended to replace the duties and responsibilities of other parties such as Governments, designers, shipbuilders, manufacturers, repairers, suppliers, contractors or sub-contractors, Owners, operators, charterers, underwriters, sellers or intended buyers of a Ship or other product or system surveyed.





These documents and activities do not relieve such parties from any fulfilment, warranty, responsibility, duty or obligation (also of a contractual nature) expressed or implied or in any case incumbent on them, nor do they confer on such parties any right, claim or cause of action against the Society. With particular regard to the duties of the ship Owner, the Services undertaken by the Society do not relieve the Owner of his duty to ensure proper maintenance of the Ship and ensure seaworthiness at all times. Likewise, the Rules, surveys performed, reports, certificates and other documents issued by the Society are intended neither to guarantee the buyers of the Ship, its components or any other surveyed or certified item, nor to relieve the seller of the duties arising out of the law or the contract, regarding the quality, commercial value or characteristics of the item which is the subject of transaction.

In no case, therefore, shall the Society assume the obligations incumbent upon the above-mentioned parties, even when it is consulted in connection with matters not covered by its Rules or other documents.

In consideration of the above, the Interested Party undertakes to relieve and hold harmless the Society from any third-party claim, as well as from any liability about the latter concerning the Services rendered.

Insofar as they are not expressly provided for in these General Conditions, the duties and responsibilities of the Owner and Interested Parties concerning the services rendered by the Society are described in the Rules applicable to the specific service rendered.

4. Service Request & Contract Management

4.1. Any request for the Society's Services shall be submitted in writing and signed by or on behalf of the Interested Party. Such a request will be considered irrevocable as soon as received by the Society and shall entail acceptance by the applicant of all relevant requirements of the Rules, including these General Conditions. Upon acceptance of the written request by the Society, a contract between the Society and the Interested Party is entered into, which is regulated by the present General Conditions.

4.2 In consideration of the Services rendered by the Society, the Interested Party and the person requesting the service shall be jointly liable for the payment of the relevant fees, even if the service is not concluded for any cause not pertaining to the Society. In the latter case, the Society shall not be held liable for non-fulfilment or partial fulfilment of the Services requested.

4.3 The contractor for the classification of a ship or for the services may be terminated and any certificates revoked at the request of one of the parties, subject to at least 30/60/90 days' notice, to be given in writing. Failure to pay, even in part, the fees due for services carried out by the society will entitle the society to immediately terminate the contract and suspend the service.

For every termination of the contract, the fees for the activities performed until the time of the termination shall be owned to the society as well as the expenses incurred in view of activities already programmed, this is without prejudice to the right to compensation due to the society as a consequence of the termination.

With particular reference to ship classification and certification, unless decided otherwise by the society, termination of the contract implies that the assignment of class to a ship is withheld or, if already assigned, that it is suspended or withdrawn, any statutory certificates issued by society will be withdrawn in those cases where provided for by agreements between the society and the flag state.

5. Service Accuracy

5.1. In providing the Services, as well as other correlated information or advice, the Society, its Surveyors, servants or agents operate with due diligence for the proper execution of the activity. However, considering the nature of the activities performed (see **Rule Development, Implementation and Selection of Surveyor 2.4**), it is not possible to guarantee absolute accuracy, correctness and completeness of any information or advice supplied. Express and implied warranties are specifically disclaimed.





6. Confidentiality & Document sharing

6.1. All plans, specifications, documents and information provided by, issued by, or made known to the Society, in connection with the performance of its Services, will be treated as confidential and will not be made available to any other party other than the Owner without authorization of the Interested Party, except as provided for or required by any applicable international, European or domestic legislation, Charter or other IACS resolutions, or order from a competent authority. Information about the status and validity of class and statutory certificates, including transfers, changes, suspensions, withdrawals of class, recommendations/conditions of class, operating conditions or restrictions issued against classed ships and other related information, as may be required, may be published on the website or released by other means, without the prior consent of the Interested Party.

Information about the status and validity of other certificates and statements may also be published on the website or released by other means, without the prior consent of the Interested Party.

6.2. Notwithstanding the general duty of confidentiality owed by the Society to its clients in clause 7.1 below, the Society's clients hereby accept that the Society may participate in the IACS Early Warning System which requires each Classification Society to provide other involved Classification Societies with relevant technical information on serious hull structural and engineering systems failures, as defined in the IACS Early Warning System (but not including any drawings relating to the ship which may be the specific property of another party), to enable such useful information to be shared and used to facilitate the proper working of the IACS Early Warning System. The Society will provide its clients with written details of such information sent to the involved Classification Societies.

6.3. In the event of transfer of class, addition of a second class or withdrawal from a double/dual-class, the Interested Party undertakes to provide or to permit the Society to provide the other Classification Society with all building plans and drawings, certificates, documents and information relevant to the classed unit, including its history file, as the other Classification Society may require for classification in compliance with the applicable legislation and relative IACS Procedure. It is the Owner's duty to ensure that, whenever required, the consent of the builder is obtained about the provision of plans and drawings to the new Society, either by way of the appropriate stipulation in the building contract or by other agreement.

In the event that the ownership of the ship, product or system subject to certification is transferred to a new subject, the latter shall have the right to access all pertinent drawings, specifications, documents or information issued by the Society or which has come to the knowledge of the Society while carrying out its Services, even if related to a period prior to transfer of ownership.

7. Health, Safety & Environment

7.1. The clients such as the designers, shipbuilders, manufacturers, repairers, suppliers, contractors or sub-contractors, or other product or system surveyed who have a registered office in ABU Dhabi; should have an approved OSHAD as per Abu Dhabi OHS Centre, or, if they do not need to have an approved OSHAD, they shall comply with TASNEEF standards and have procedures in place to manage the risks from their undertakings.

7.2. For the survey, audit and inspection activities onboard the ship, the ship's owner, the owner representative or the shipyard must follow TASNEEF rules regarding the safety aspects.

8. Validity of General Conditions

8.1. Should any part of these General Conditions be declared invalid, this will not affect the validity of the remaining provisions.





9. Force Majeure

9.1 Neither Party shall be responsible to the other party for any delay or failure to carry out their respective obligations insofar as such delay and failure derives, directly or indirectly, and at any time, from force majeure of any type whatsoever that lies outside the control of either Party.

9.2 The Party that is unable to fulfil the agreement due to Force Majeure shall inform the other party without delay and in all cases within 7 days from when such force majeure arose.

9.3 It is understood that if such force majeure continues for more than 30 days, the Party not affected by the event may terminate this agreement by registered letter. The rights matured until the day in which the force majeure occurred remain unaffected.

10. Governing Law and Jurisdiction

This Agreement shall be governed by and construed in accordance with the laws of Abu Dhabi and the applicable Federal Laws of the UAE.

Any dispute arising out of or in accordance with this Agreement shall be subject to the exclusive jurisdiction of the Abu Dhabi courts.

11. Code of Business conduct

The **CLIENT** declares to be aware of the laws in force about the responsibility of the legal persons for crimes committed in their interest or to their own advantage by persons who act on their behalf or cooperate with them, such as directors, employees or agents.

In this respect, the **CLIENT** declares to have read and fully understood the "**Ethical Code**" published by **TASNEEF** and available in the **TASNEEF** Web site.

The **CLIENT**, in the relationships with **TASNEEF**, guarantees to refrain from any behaviour that may incur risk of entry in legal proceedings for crimes or offences, whose commission may lead to the enforcement of the laws above.

The **CLIENT** also acknowledges, in case of non-fulfilment of the previous, the right of **TASNEEF** to unilaterally withdraw from the contract/agreement even if there would be a work in progress situation or too early terminate the contract/agreement. It's up to **TASNEEF** to choose between the two above mentioned alternatives, and in both cases a registered letter will be sent with a brief sum-up of the circumstances or of the legal procedures proving the failure in following the requirements of the above-mentioned legislation.

In light of the above, it is forbidden to all employees and co-operators to:

- receive any commission, percentage or benefits of any possible kind;
- Start and maintaining any business relationship with **Clients** that could cause conflict of interests with their task and function covered on behalf of **TASNEEF**.
- Receive gifts, travel tickets or any other kind of benefits different from monetary compensation, that could exceed the ordinary business politeness.

Violation of the above-mentioned principles allows **TASNEEF** to early terminate the contract and to be entitled to claim compensation for losses if any.



EXPLANATORY NOTE TO PART C

1. Reference edition

The reference edition for Part C is the Tasneef Rules 2000 edition, which is effective from 1 June 2000.

2. Amendments after the reference edition

2.1 Tasneef Rules 2000 has been completely rewritten and reorganised.

2.2 Except in particular cases, the Rules are updated and published annually.

3. Effective date of the requirements

3.1 All requirements in which new or amended provisions with respect to those contained in the reference edition have been introduced are followed by a date shown in brackets.

The date shown in brackets is the effective date of entry into force of the requirements as amended by the last updating. The effective date of all those requirements not followed by any date shown in brackets is that of the reference edition.

3.2 Item 6 below provides a summary of the technical changes from the preceding edition. In general, this list does not include those items to which only editorial changes have been made not affecting the effective date of the requirements contained therein.

4. Rule Variations and Corrigenda

Until the next edition of the Rules is published, Rule Variations and/or corrigenda, as necessary, will be published on the Tasneef web site (www.Tasneef.ae). Except in particular cases, paper copies of Rule Variations or corrigenda are not issued.

5. Rule subdivision and cross-references

5.1 Rule subdivision

The Rules are subdivided into six parts, from A to F.

Part A: Classification and Surveys

Part B: Hull and Stability

Part C: Machinery, Systems and Fire Protection

Part D: Materials and Welding

Part E: Service Notations

Part F: Additional Class Notations

Each Part consists of:

- Chapters
- Sections and possible Appendices
- Articles
- Sub-articles
- Requirements

Figures (abbr. Fig) and Tables (abbr. Tab) are numbered in ascending order within each Section or Appendix.

5.2 Cross-references

Examples: Pt A, Ch 1, Sec 1, [3.2.1] or Pt A, Ch 1, App 1, [3.2.1]

- Pt A means Part A

The part is indicated when it is different from the part in which the cross-reference appears. Otherwise, it is not indicated.

- Ch 1 means Chapter 1

The Chapter is indicated when it is different from the chapter in which the cross-reference appears. Otherwise, it is not indicated.

- Sec 1 means Section 1 (or App 1 means Appendix 1)

The Section (or Appendix) is indicated when it is different from the Section (or Appendix) in which the cross-reference appears. Otherwise, it is not indicated.

- [3.2.1] refers to requirement 1, within sub-article 2 of article 3.

Cross-references to an entire Part or Chapter are not abbreviated as indicated in the following examples:

- Part A for a cross-reference to Part A
- Part A, Chapter 1 for a cross-reference to Chapter 1 of Part A.

6. Summary of amendments introduced in the edition effective from 1 January 2024

This edition of Part C contains amendments whose effective date is **1 January 2024**.

The date of entry into force of each new or amended item is shown in brackets after the number of the item concerned.

Chapters 1 **2 3 4**

Chapter 1	MACHINERY
Chapter 2	ELECTRICAL INSTALLATIONS
Chapter 3	AUTOMATION
Chapter 4	FIRE PROTECTION, DETECTION AND EXTINCTION

CHAPTER 2

ELECTRICAL INSTALLATIONS

Section 1 General

1	Application	23
1.1	General	
1.2	References to other regulations and standards	
2	Documentation to be submitted	23
2.1		
3	Definitions	24
3.1	General	
3.2	Essential services	
3.3	Primary essential services	
3.4	Secondary essential services	
3.5	Safety voltage	
3.6	Low-voltage systems	
3.7	High-voltage systems	
3.8	Basic insulation	
3.9	Supplementary insulation	
3.10	Double insulation	
3.11	Reinforced insulation	
3.12	Earthing	
3.13	Normal operational and habitable condition	
3.14	Emergency condition	
3.15	Main source of electrical power	
3.16	Dead ship condition	
3.17	Main generating station	
3.18	Main switchboard	
3.19	Emergency switchboard	
3.20	Emergency source of electrical power	
3.21	Distribution board	
3.22	Final sub-circuit	
3.23	Motor control centre (MCC)	
3.24	Hazardous areas	
3.25	Certified safe-type equipment	
3.26	Environmental categories	
3.27	Navigation Light (NL)	

Section 2 General Design Requirements

1	Environmental conditions	32
1.1	General	
1.2	Ambient air temperatures	
1.3	Humidity	
1.4	Cooling water temperatures	
1.5	Salt mist	
1.6	Inclinations	
1.7	Vibrations	

2	Quality of power supply	33
	2.1 Voltage and frequency variation	
	2.2 Harmonic distortions	
3	Electromagnetic susceptibility	34
	3.1	
4	Materials	34
	4.1 General	
	4.2 Insulating materials for windings	
	4.3 Insulating materials for cables	
5	Construction	35
	5.1 General	
	5.2 Degree of protection of enclosures	
6	Protection against explosion hazard	35
	6.1 Protection against explosive gas or vapour atmosphere hazard	
	6.2 Protection against combustible dust hazard	

Section 3 System Design

1	Supply systems and characteristics of the supply	37
	1.1 Supply systems	
	1.2 Maximum voltages	
2	Sources of electrical power	38
	2.1 General	
	2.2 Main source of electrical power	
	2.3 Emergency source of electrical power	
	2.4 Use of emergency generator in port	
3	Distribution	41
	3.1 Earthed distribution systems	
	3.2 Insulated distribution systems	
	3.3 Distribution systems with hull return	
	3.4 General requirements for distribution systems	
	3.5 Harmonic distortion for ship electrical distribution system including harmonic filters	
	3.6 Main distribution of electrical power	
	3.7 Emergency distribution of electrical power	
	3.8 Shore supply	
	3.9 Supply of motors	
	3.10 Specific requirements for special power services	
	3.11 Power supply to heaters	
	3.12 Power supply to lighting installations	
	3.13 Special lighting services	
	3.14 Navigation lights	
	3.15 General emergency alarm system	
	3.16 Public address system	
	3.17 Combined general emergency alarm - public address system	
	3.18 Control and indication circuits	
	3.19 Power supply to the speed control systems of main propulsion engines	
	3.20 Power supply to the speed control systems of generator sets	
4	Degrees of protection of the enclosures	47
	4.1 General	

5	Diversity (demand) factors	49
	5.1 General	
6	Environmental categories of the equipment	49
	6.1 Environmental categories	
7	Electrical protection	49
	7.1 General requirements for overcurrent protection	
	7.2 Short-circuit currents	
	7.3 Selection of equipment	
	7.4 Protection against short-circuit	
	7.5 Continuity of supply and continuity of service	
	7.6 Protection against overload	
	7.7 Localisation of overcurrent protection	
	7.8 Protection of generators	
	7.9 Protection of circuits	
	7.10 Protection of motors	
	7.11 Protection of storage batteries	
	7.12 Protection of shore power connection	
	7.13 Protection of measuring instruments, pilot lamps and control circuits	
	7.14 Protection of transformers	
8	System components	54
	8.1 General	
9	Electrical cables	54
	9.1 General	
	9.2 Choice of insulation	
	9.3 Choice of protective covering	
	9.4 Cables in refrigerated spaces	
	9.5 Cables in areas with a risk of explosion	
	9.6 Electrical services required to be operable under fire conditions and fire-resistant cables	
	9.7 Cables for submerged bilge pumps	
	9.8 Internal wiring of switchboards and other enclosures for equipment	
	9.9 Current carrying capacity of cables	
	9.10 Minimum nominal cross-sectional area of conductors	
	9.11 Choice of cables	
10	Electrical installations in hazardous areas	60
	10.1 Electrical equipment	
	10.2 Electrical cables	
	10.3 Electrical installations in battery rooms	
	10.4 Electrical equipment allowed in paint stores and in enclosed spaces leading to paint stores	
	10.5 Electrical installations in stores for welding gas (acetylene) bottles	
	10.6 Special ships	
11	Recording of the Type, Location and Maintenance Cycle of Batteries	62
	11.1 Battery schedule	

Section 4 Rotating Machines

1	Constructional and operational requirements for generators and motors	64
	1.1 Mechanical construction	
	1.2 Sliprings, commutators and brushes	

	1.3	Terminal connectors	
	1.4	Electrical insulation	
2		Special requirements for generators	64
	2.1	Prime movers, speed governors and overspeed protection	
	2.2	A.c. generators	
3		Testing of rotating machines	65
	3.1	General	
	3.2	Shaft material	
	3.3	Tests	
4		Description of the test	66
	4.1	Examination of the technical documentation, as appropriate, and visual inspection	
	4.2	Insulation resistance measurement	
	4.3	Winding resistance measurement	
	4.4	Verification of the voltage regulation system	
	4.5	Rated load test and temperature rise measurements	
	4.6	Overload/overcurrent tests	
	4.7	Verification of steady short-circuit conditions	
	4.8	Overspeed test	
	4.9	Dielectric strength test	
	4.10	No load test	
	4.11	Verification of degree of protection	
	4.12	Verification of bearings	
5		Requirements for AC Generating sets	68
	5.1	General	
	5.2	Generating sets - requirements	

Section 5 Transformers

1		Constructional and operational requirements	69
	1.1	Construction	
	1.2	Terminals	
	1.3	Short-circuit conditions and parallel operation	
	1.4	Electrical insulation and temperature rise	
	1.5	Insulation tests	
2		Testing	70
	2.1	General	
	2.2	Tests on transformers	

Section 6 Semiconductor Convertors

1		Constructional and operational requirements	71
	1.1	Construction	
	1.2	Protection	
	1.3	Parallel operation with other power sources	
	1.4	Temperature rise	
	1.5	Insulation test	
2		Testing	72
	2.1	General	
	2.2	Tests on convertors	

Section 7 Storage Batteries, Chargers, Uninterruptible Power Systems and Fuel Cells

1	Constructional requirements for batteries	73
1.1	General	
1.2	Vented batteries	
1.3	Valve-regulated sealed batteries	
1.4	Tests on batteries	
2	Constructional requirements for chargers	73
2.1	Characteristics	
2.2	Tests on chargers	
3	Uninterruptible power system (UPS) units as alternative and/or transitional power	74
3.1	Application	
3.2	Definitions	
3.3	Design and construction	
3.4	Location	
3.5	Performance	
3.6	Testing and survey	
4	Fuel cells	75
4.1	General	

Section 8 Switchgear and Controlgear Assemblies

1	Constructional requirements for main and emergency switchboards	76
1.1	Construction	
1.2	Busbars and bare conductors	
1.3	Internal wiring	
1.4	Switchgear and controlgear, protective devices	
1.5	Fuses	
1.6	Auxiliary circuits	
1.7	Instruments	
2	Constructional requirements for distribution boards	79
2.1	Construction	
3	Testing	79
3.1	General	
3.2	Inspection of equipment, check of wiring and electrical operation test	
3.3	High voltage test	
3.4	Measurement of insulation resistance	

Section 9 Cables

1	Constructional requirements	81
1.1	Construction	
1.2	Conductors	
1.3	Insulating materials	
1.4	Inner covering, fillers and binders	
1.5	Protective coverings (armour and sheath)	

	1.6	Identification	
2		Testing	82
	2.1	Type tests	
	2.2	Routine tests	

Section 10 Miscellaneous Equipment

1		Lighting fittings	83
	1.1	Applicable requirements	
	1.2	Construction	
2		Accessories	83
	2.1	Applicable requirements	
	2.2	Construction	
3		Plug-and-socket connections	83
	3.1	Applicable requirements	
4		Heating and cooking appliances	83
	4.1	Applicable requirements	
	4.2	General	
	4.3	Space heaters	
	4.4	Cooking appliances	
	4.5	Fuel oil and lube oil heaters	
	4.6	Water heaters	
5		Cable trays/protective casings made of plastics materials	84
	5.1	General requirement	
	5.2	Installation Requirements	

Section 11 Location

1		General	85
	1.1	Location	
	1.2	Areas with a risk of explosion	
2		Main electrical system	85
	2.1	Location in relation to the emergency system	
	2.2	Main switchboard	
3		Emergency electrical system	85
	3.1	Spaces for the emergency source	
	3.2	Location in relation to the main electrical system	
	3.3	Emergency switchboard	
	3.4	Emergency battery	
4		Distribution boards	86
	4.1	Distribution boards for cargo spaces and similar spaces	
	4.2	Distribution board for navigation lights	
5		Cable runs	86
	5.1	General	
	5.2	Location of cables in relation to the risk of fire and overheating	

5.3	Location of cables in relation to electromagnetic interference	
5.4	Services with a duplicate feeder	
5.5	Emergency circuits	
5.6	Electrical distribution in passenger ships	
6	Storage batteries	87
6.1	General	
6.2	Large vented batteries	
6.3	Moderate vented batteries	
6.4	Small vented batteries	
6.5	Ventilation	

Section 12 Installation

1	General	89
1.1	Protection against injury or damage caused by electrical equipment	
1.2	Protection against damage to electrical equipment	
1.3	Accessibility	
2	Earthing of non-current carrying parts	89
2.1	Parts which are to be earthed	
2.2	Methods of earthing	
2.3	Earthing connections	
2.4	Connection to the ship's structure	
2.5	Earthed distribution systems	
2.6	Aluminium superstructures	
3	Rotating machines	90
3.1		
4	Semiconductor convertors	91
4.1	Semiconductor power convertors	
5	Vented type storage batteries	91
5.1	General	
5.2	Protection against corrosion	
6	Switchgear and controlgear assemblies	91
6.1	Main switchboard	
6.2	Emergency switchboard	
6.3	Distribution boards	
7	Cables	92
7.1	General	
7.2	Radius of bend	
7.3	Fixing of cables	
7.4	Mechanical protection	
7.5	Penetrations of bulkheads and decks	
7.6	Expansion joints	
7.7	Cables in closed pipes or conduits	
7.8	Cables in casings or trunking and conduits with removable covers	
7.9	Cable ends	
7.10	Joints and tapplings (branch circuit)	
7.11	Earthing and continuity of metal coverings of cables	
7.12	Earthing and continuity of metal pipes, conduits and trunking or casings	
7.13	Precautions for single-core cables for a.c.	

- 7.14 Cables in refrigerated spaces
- 7.15 Cables in areas with a risk of explosion
- 7.16 Cables in the vicinity of radio equipment
- 7.17 Cables for submerged bilge pumps

8	Various appliances	97
	8.1 Lighting fittings	
	8.2 Heating appliances	
	8.3 Heating cables and tapes or other heating elements	

Section 13 High Voltage Installations

1	General	99
	1.1 Field of application	
	1.2 Nominal system voltage	
	1.3 High-voltage, low-voltage segregation	
2	System Design	99
	2.1 Distribution	
	2.2 Degrees of protection	
	2.3 Insulation	
	2.4 Protection	
3	Rotating machinery	100
	3.1 Stator windings of generators	
	3.2 Temperature detectors	
	3.3 Tests	
4	Power Transformers	101
	4.1 General	
5	Cables	101
	5.1 General	
6	Fuses	101
	6.1 General	
7	Switchgear and controlgear assemblies	101
	7.1 General	
	7.2 Construction	
	7.3 Auxiliary systems	
	7.4 High voltage test	
8	Installation	102
	8.1 Electrical equipment	
	8.2 Cables	

Section 14 Electric Propulsion Plant

1	General	103
	1.1 Applicable requirements	
	1.2 Operating conditions	
2	Design of the propulsion plant	103
	2.1 General	
	2.2 Power supply	

2.3	Auxiliary machinery	
2.4	Electrical Protection	
2.5	Excitation of electric propulsion motor	
3	Construction of rotating machines and semiconductor convertors	104
3.1	Ventilation	
3.2	Protection against moisture and condensate	
3.3	Rotating machines	
3.4	Semiconductor convertors	
4	Control and monitoring	105
4.1	General	
4.2	Power plant control systems	
4.3	Indicating instruments	
4.4	Alarm system	
4.5	Reduction of power	
5	Installation	106
5.1	Ventilation of spaces	
5.2	Cable runs	
6	Tests	106
6.1	Test of rotating machines	
7	Specific requirements for PODs	107
7.1	General	
7.2	Rotating commutators	
7.3	Electric motors	
7.4	Instrumentation and associated devices	
7.5	Additional tests	

Section 15 Testing

1	General	108
1.1	Rule application	
1.2	Insulation-testing instruments	
2	Type approved components	108
2.1		
3	Insulation resistance	108
3.1	Lighting and power circuits	
3.2	Internal communication circuits	
3.3	Switchboards	
3.4	Generators and motors	
4	Earth	109
4.1	Electrical constructions	
4.2	Metal-sheathed cables, metal pipes or conduits	
5	Operational tests	109
5.1	Generating sets and their protective devices	
5.2	Switchgear	
5.3	Consuming devices	
5.4	Communication systems	
5.5	Installations in areas with a risk of explosion	
5.6	Voltage drop	

Appendix 1 Indirect Test Method for Synchronous Machines

1	General	111
1.1	Test method	

Appendix 2 Battery Powered Ships

1	General	113
1.1	Application	
1.2	Definitions	
1.3	Documentation to be submitted	
2	System design	113
2.1	General	
2.2	Constructional requirements	
2.3	Electrical protection	
2.4	Battery charger	
3	Control, monitoring, alarm and safety systems	116
3.1	General	
3.2	Battery management systems (BMS)	
3.3	Alarm system	
3.4	Safety system	
3.5	Energy Management system	
4	Location	117
4.1	General	
4.2	Battery space	
5	Testing	119
5.1	General	
5.2	Testing and inspection at Manufacturer premises	
5.3	Testing and inspection after installation on board	
5.4	Plans to be kept on board	

Appendix 3 Fuel Cell Powered Ships

1	General	122
1.1	Scope	
1.2	Documentation to be submitted	
1.3	Definitions	MSC.1/Circ.1647 REFERENCE: para. 1.4
2	Goal and functional requirements	MSC.1/Circ.1647 REFERENCE: para. 1.2 and 1.3 124
2.1	Goal	
2.2	Functional requirements	
3	Alternative design	MSC.1/Circ.1647 REFERENCE: para. 1.5 125
3.1		
4	Design principles for fuel cell power installations	MSC.1/Circ.1647 REFERENCE: para. 2 125
4.1	Fuel cell spaces	

	4.2	Arrangement and access	
	4.3	Atmospheric control of fuel cell spaces	
	4.4	Materials	
	4.5	Piping arrangement for fuel cell power system	
	4.6	Exhaust gas and exhaust air	
5	Fire safety		MSC.1/Circ.1647 REFERENCE: para. 3 126
	5.1		
6	Electrical systems		MSC.1/Circ.1647 REFERENCE: para. 4 126
	6.1	General provisions on electrical systems	
	6.2	Area classification	
	6.3	Risk assessment	
7	Control, monitoring and safety systems		MSC.1/Circ.1647 REFERENCE: para. 5 127
	7.1	General provisions on control, monitoring and safety systems	
	7.2	Gas or vapour detection	
	7.3	Ventilation performance	
	7.4	Bilge wells	
	7.5	Manual emergency shutdown	
	7.6	Actions of the alarm system and safety system	
	7.7	Alarms	
	7.8	Safety actions	
8	Tests on board		127
	8.1	Functioning Tests	
	8.2	Hot spot verification	
9	Material Test, Workshop inspections and testing		128
	9.1	General principles	
	9.2	Type approval	
	9.3	Production testing	

CHAPTER 3

AUTOMATION

Section 1 General Requirements

1	General	131
1.1	Field of application	
1.2	Regulations and standards	
1.3	Definitions	
1.4	General	
2	Documentation	132
2.1	General	
2.2	Documents to be submitted	
2.3	Documents for programmable electronic system	
2.4	Documents for type approval of equipment	
3	Environmental and supply conditions	133
3.1	General	
3.2	Power supply conditions	
4	Materials and construction	134
4.1	General	
4.2	Type approved components	

Section 2 Design Requirements

1	General	135
1.1		
2	Power supply of automation systems	135
2.1	General	
3	Control systems	135
3.1	General	
3.2	Local control	
3.3	Remote control systems	
3.4	Automatic control systems	
4	Control of propulsion machinery	136
4.1	Remote control	
4.2	Remote control from navigating bridge	
4.3	Automatic control	
4.4	Automatic control of propulsion and manoeuvring units	
4.5	Clutches	
4.6	Brakes	
5	Remote control of valves	137
5.1		
6	Alarm system	137
6.1	General requirements	

6.2	Alarm functions	
7	Safety system	138
7.1	Design	
7.2	Function	
7.3	Shutdown	
7.4	Standby systems	
7.5	Testing	

Section 3 Computer Based Systems

1	Scope	139
1.1	General	
1.2	Reference to other regulations and standards	
1.3	Structure	
1.4	Abbreviations	
1.5	Definitions	
2	Approval of system and components	141
2.1		
3	System categories	142
3.1	System category definitions	
3.2	Class Societies' scope	
3.3	System category examples	
4	Requirements on development and certification of computer-based system	142
4.1	General requirements	
4.2	Requirements on the system supplier	
4.3	Requirements on the systems integrator	
5	Requirements on maintenance of computer-based systems	146
5.1	Requirements on the Vessel Owner	
5.2	Requirements on the Systems integrator	
5.3	Requirements on the System Supplier	
6	Management of change	147
6.1	General	
6.2	Documented change management procedures	
6.3	Agreement between relevant stakeholders	
6.4	Approved software shall be under change management	
6.5	Unique identification of system and software versions	
6.6	Handling of software master files	
6.7	Backup and restoration of onboard software	
6.8	Impact analysis before change is made	
6.9	Roll-back in case of failed software changes	
6.10	Verification and validation of system changes	
6.11	Change records	
6.12	Verification of change management by the Society	
7	Technical requirements on computer-based systems	148
7.1	General	
7.2	Reporting of system and software identification and version	
7.3	Data links	
7.4	Verification of technical requirements by the Society	

8	Summary of documentation submittal	149
	8.1	
9	Summary of test witnessing and survey	150
	9.1	

Section 4 Cyber Resilience of Ships

1	Introduction	151
	1.1 General	
	1.2 Structure of this Section	
	1.3 Aim and purpose	
	1.4 Scope of applicability	
2	Definitions	152
	2.1 General	
3	Goals and organization of requirements	154
	3.1 Primary goal	
	3.2 Sub-goals per functional element	
	3.3 Organization of requirements	
4	Requirements	154
	4.1 General	
	4.2 Identify	
	4.3 Protect	
	4.4 Detect	
	4.5 Respond	
	4.6 Recover	
5	Demonstration of compliance	170
	5.1 General	
	5.2 During design and construction phases	
	5.3 Upon ship commissioning	
	5.4 During the operational life of the ship	
6	Risk assessment for exclusion of CBS from the application of requirements	172
	6.1 Requirement	
	6.2 Rationale	
	6.3 Requirement details	
	6.4 Acceptance criteria	
7	Summary of actions and documents	172
	7.1 General	
8	Summary of requirements and documents	174
	8.1 General	

Section 5 Cyber Resilience of on-board Systems and Equipment

1	General	178
	1.1 Introduction	
	1.2 Limitations	

1.3	Scope of applicability	
1.4	Definitions & Abbreviations	
1.5	Requirements and Credits	
2	Security Philosophy	180
2.1	Systems and Equipment	
2.2	Cyber Resilience	
2.3	Essential Systems Availability	
2.4	Compensating Countermeasures	
3	Documentation	180
3.1	CBS Documentation	
4	System Requirements	182
4.1	General	
4.2	Required security capabilities	
4.3	Additional security capabilities	
5	Secure Development Lifecycle Requirements	185
5.1	General	
6	Demonstration of compliance	186
6.1	General	
6.2	Plan approval	
6.3	Survey and factory acceptance test	

Section 6 Constructional Requirements

1	General	190
1.1	Construction	
1.2	Materials	
1.3	Component design	
1.4	Environmental and supply conditions	
2	Electrical and/or electronic systems	190
2.1	General	
2.2	Electronic system	
2.3	Electrical system	
3	Pneumatic systems	191
3.1		
4	Hydraulic systems	191
4.1		
5	Automation consoles	191
5.1	General	
5.2	Indicating instruments	
5.3	VDU's and keyboards	

Section 7 Installation Requirements

1	General	192
1.1		

2	Sensors and components	192
	2.1 General	
	2.2 Temperature elements	
	2.3 Pressure elements	
	2.4 Level switches	
3	Cables	192
	3.1 Installation	
	3.2 Cable terminations	
4	Pipes	193
	4.1	
5	Automation consoles	193
	5.1 General	

Section 8 Testing

1	General	194
	1.1 Commissioning	
2	Type approval	194
	2.1 General	
	2.2 Hardware type approval	
	2.3 Software type approval	
	2.4 Navigational and radio equipment	
	2.5 Loading instruments	
3	Acceptance testing	203
	3.1 General	
	3.2 Hardware testing	
	3.3 Software testing	
4	Commissioning	204
	4.1 General	

CHAPTER 4

FIRE PROTECTION, DETECTION AND EXTINCTION

Section 1 Requirements for Fire Protection, Detection and Extinction

1	General	207
1.1	Purpose and application	
2	Documentation to be submitted	207
2.1		
3	Definitions	208
3.1	Accommodation spaces	
3.2	Airlock	
3.3	Ballast Water Management System (BWMS)	
3.4	Ballast Water Management Room (BWMR)	
3.5	BWMS storing, introducing or generating chemicals	
3.6	Cargo area	
3.7	Cargo ship	
3.8	Cargo spaces	
3.9	Chemical tanker	
3.10	Closed ro-ro spaces	
3.11	Closed vehicle spaces	
3.12	Combination carriers	
3.13	Continuously manned central control stations	
3.14	Control stations	
3.15	Crude oil	
3.16	Deadweight	
3.17	Flashpoint	
3.18	Gas carrier	
3.19	Lightweight	
3.20	Machinery spaces	
3.21	Machinery spaces of category A	
3.22	Main vertical zones	
3.23	Oil fuel unit	
3.24	Open decks (open deck spaces)	
3.25	Open ro-ro spaces	
3.26	Open vehicle spaces	
3.27	Passenger ship	
3.28	Public spaces	
3.29	Ro-ro spaces	
3.30	Ro-ro passenger ship	
3.31	Service spaces	
3.32	Special category spaces	
3.33	Tanker	
3.34	Vehicle spaces	
3.35	Weather decks	
4	Type approved products	210
4.1		
5	Probability of ignition	211
5.1	Arrangements for gaseous fuel for domestic purposes	
5.2	Cargo area of tankers	

	5.3	Non-sparking fans	
6		Suppression of fire - detection and alarm	213
	6.1	Protection of machinery spaces	
7		Suppression of fire: fire - fighting	213
	7.1	Fire-extinguishing arrangements in machinery spaces	
	7.2	Low pressure CO2 piping system	
8		Fire safety systems: General requirements and application for inert gas systems	215
	8.1	General requirements	
	8.2	Application	
	8.3	Requirements for equivalent systems	
9		Inert gas systems	215
	9.1	Contents	
	9.2	Engineering specifications	
	9.3	Requirements for all systems	
	9.4	Requirements for flue gas and inert gas generator systems	
	9.5	Requirements for nitrogen generator systems	
	9.6	Nitrogen /Inert Gas Systems Fitted for Purposes other than Inerting Required by SOLAS Reg. II-2/4.5.5.1 and 4.5.5.2	
10		Installation of BWMS on-board ships	220
	10.1	General	
	10.2	Fire categorization	
	10.3	BWMR location and boundaries	
	10.4	Fire fighting	
	10.5	Fire prevention	
	10.6	Ventilation	
	10.7	Personal equipment	

Part C

Machinery, Systems and Fire Protection

Chapter 2

ELECTRICAL INSTALLATIONS

SECTION 1	GENERAL
SECTION 2	GENERAL DESIGN REQUIREMENTS
SECTION 3	SYSTEM DESIGN
SECTION 4	ROTATING MACHINES
SECTION 5	TRANSFORMERS
SECTION 6	SEMICONDUCTOR CONVERTORS
SECTION 7	STORAGE BATTERIES, CHARGERS, UNINTERRUPTIBLE POWER SYSTEMS AND FUEL CELLS
SECTION 8	SWITCHGEAR AND CONTROLGEAR ASSEMBLIES
SECTION 9	CABLES
SECTION 10	MISCELLANEOUS EQUIPMENT
SECTION 11	LOCATION
SECTION 12	INSTALLATION
SECTION 13	HIGH VOLTAGE INSTALLATIONS
SECTION 14	ELECTRIC PROPULSION PLANT
SECTION 15	TESTING
APPENDIX 1	INDIRECT TEST METHOD FOR SYNCHRONOUS MACHINES
APPENDIX 2	BATTERY POWERED SHIPS
APPENDIX 3	FUEL CELL POWERED SHIPS

SECTION 1

GENERAL

1 Application

1.1 General

1.1.1 The requirements of this Chapter apply to electrical installations on ships. In particular, they apply to the components of electrical installations for:

- primary essential services
- secondary essential services
- essential services for special purposes connected with ships specifically intended for such purposes (e.g. cargo pumps on tankers, cargo refrigerating systems, air conditioning systems on passenger ships)
- services for habitability.

The other parts of the installation are to be so designed as not to introduce any risks or malfunctions to the above services.

1.1.2 (1/7/2007)

As stated in Note 1 to Pt A, Ch 1, Sec 1, [1.1.2], the statutory requirements of the SOLAS Convention and/or national safety regulations, as applicable, regarding fire protection, detection and extinction (hereinafter referred to as "fire protection statutory requirements") are no longer mandatory for the purpose of classification, except where the Society carries out surveys relevant to fire protection statutory requirements on behalf of the flag Administration. In such cases, fire protection statutory requirements are considered a matter of class and therefore compliance with these requirements is also verified by the Society for classification purposes.

1.1.3 (1/7/2019)

The Society may consider modified requirements for installations of ships having navigation notation "sheltered area" or "special navigation" in an area at not more than 6 miles from the shore.

1.2 References to other regulations and standards

1.2.1 The Society may refer to other regulations and standards when deemed necessary. These include the IEC publications, notably the IEC 60092 series.

1.2.2 When referred to by the Society, publications by the International Electrotechnical Commission (IEC) or other internationally recognised standards, are those currently in force at the date of agreement for ship classification.

2 Documentation to be submitted

2.1

2.1.1 The documents listed in Tab 1 are to be submitted. The list of documents requested is to be intended as guidance for the complete set of information to be submitted, rather than an actual list of titles.

The Society reserves the right to request the submission of additional documents in the case of non-conventional design or if it is deemed necessary for the evaluation of the system, equipment or components.

Unless otherwise agreed with the Society, documents for approval are to be sent in triplicate if submitted by the Shipyard and in four copies if submitted by the equipment supplier.

Documents requested for information are to be sent in duplicate.

In any case, the Society reserves the right to require additional copies when deemed necessary.

2.1.2 (1/7/2021)

In addition to the documentation listed in Tab 1, a FMEA, carried out according to the Tasneef "Guide for Failure mode and Effect Analysis" or other equivalent methods, and a Test Program, identifying the tests to be carried out in order to verify the assumptions and conclusions of the FMEA, may be requested for approval for the following systems where applicable (see Note 1):

- control and power systems to power-operated fire doors and status indication for all fire doors;
- control and power systems to power-operated watertight doors and their status indication;
- steering gear control system;
- electric propulsion control system;
- public address and general alarm system;
- remote emergency stop/shutdown arrangements for systems which may support the propagation of fire and/or explosion;
- control and power system and position indication circuits for bow doors, stern doors, side doors, inner doors.

The FMEA may be requested by the Society for other systems on a case by case basis, depending on their influence on the overall ship safety.

Note 1: where the modes of failure and their consequences are clearly identifiable from the relevant drawings the Society may waive this request.

2.1.3 (1/7/2021)

Where the Society carries out surveys relevant to fire protection statutory requirements on behalf of the flag Administration (see [1.1.2]) the additional documents listed in Tab 2 are to be submitted.

2.1.4 (1/7/2021)

When an alteration or addition to an existing installation is proposed, updated plans are to be submitted for approval. As a minimum a technical specification, schematic diagrams and a proposed list of tests to be carried out onboard at the presence of the Tasneef Surveyor are to be included.

2.1.5 (1/7/2021)

Where computer based systems are implemented and used to control the electrical installation, or to provide safety functions in accordance with the requirements of this Chapter (e.g. electric propulsion, steering gear, emergency safety systems etc.), the arrangements are to satisfy the applicable requirements of Chapter 3.

3 Definitions

3.1 General

3.1.1 Unless otherwise stated, the terms used in this Chapter have the definitions laid down by the IEC standards.

The definitions given in the following requirements also apply.

3.2 Essential services

3.2.1 Essential services are those services essential for propulsion and steering, and the safety of the ship, and services to ensure minimum comfortable conditions of habitability and necessary for special purposes connected with ships specifically intended for such purposes (e.g. cargo pumps on tankers, cargo refrigerating systems, air conditioning systems on passenger ships).

Table 1 : Documents to be submitted (1/1/2023)

No.	I/A (1)	Documents to be submitted	Notes
GENERAL			
1	A	Operation description of main, emergency and transitional electrical power systems (if applicable) under normal and foreseeable abnormal operating conditions.	
2	A	Single line diagram of main and emergency power and lighting systems.	The drawing is to include the single line diagram of: <ul style="list-style-type: none"> • the main switchboard and all the feeders connected to the main switchboard • the emergency switchboard and all feeders connected to the emergency switchboard • interconnector feeder between main switchboard and emergency switchboard • the main and emergency source of electrical power (i.e. generators and/or batteries and any additional source of power) • any distribution boards and motor control centers (MCC) • the main and emergency lighting distribution • transformers, converters and similar appliance which constitute an essential part of the electrical supply system • uninterruptible power system units (UPS) when providing an alternative power supply to essential services and/or when providing an alternative power supply or transitional power supply, if any, to the emergency services.
3	A	Electrical power balance (main and emergency supply).	The load balance of the main supply is to include the operating modes in which the ship is intended to operate.
<p>(1) A: to be submitted for approval I: to be submitted for information</p>			

No.	I/A (1)	Documents to be submitted	Notes
4	I	Calculation of short-circuit currents for installation in which the sum of rated power of the energy sources which may be connected contemporaneously to the network is greater than 500 kVA.	The calculation is to include the short circuit currents at: <ul style="list-style-type: none"> the main switchboard(s) the emergency switchboard all the distribution boards and MCC including those fed from transformers. Document is to include details of circuit breaker and fuse operating times and discrimination curves.
5	A	List of circuits including, for each supply and distribution circuit, data concerning the nominal current, the cable type, length and cross-section, nominal and setting values of the protective and control devices.	Main switchboard, emergency switchboards, each distribution board, motor control centers (MCC) and UPS and/or battery distribution.
6	A	Single line diagram and detailed functional diagram of the main switchboard	
7	A	Single line diagram and detailed functional diagram of the emergency switchboard.	
8	A	Single line diagram and detailed functional diagram of distribution boards, and 100kW and over motor control centers and single starters.	Main distribution boards are intended as distribution boards which are supplied directly or through transformer by main or emergency switchboard
9	A	Diagram and arrangement of main and emergency lighting	
10	A	Diagram and arrangement of the general emergency alarm system, the public address system and other intercommunication systems.	
11	A	A functional diagram of the distribution board specially reserved for the navigation lights.	
12	I	Schedule for recording of the type, location and maintenance cycle of batteries used for essential and emergency services.	Reference is to be made to the requirements of Sec 3, [11.1.1].
13	A	Single line diagram for electric propulsion installation, including power supply circuits.	For control alarm and safety system see Chapter 3.
14	A/I	For BATTERY POWERED SHIP documents required by App 2, Tab 1 and for FUEL CELL POWERED SHIP, documents required by App 3, Tab 1.	
15	A	A functional diagram of the electric power circuits for steering gear	Reference is to be made to the requirements of Ch 1, Sec 11, [2.3], [2.4], [3] & [4]. For control alarm and safety system see Chapter 3
16	A	Electrical diagram of local application fixed gas fire-extinguishing systems.	Reference is to be made to the requirements of Ch 4, Sec 1, [7.1.2]
17	A	Electrical diagrams of power control and position indication circuits of watertight doors	Reference is to be made to the requirements of: <ul style="list-style-type: none"> Pt B, Ch 2, Sec 1, [6] Pt E, Ch 11, Sec 2
(1) A: to be submitted for approval I: to be submitted for information			

No.	I/A (1)	Documents to be submitted	Notes
18	I	General arrangement plan of the ship showing location of main items of the electrical system	The plan is to include: <ul style="list-style-type: none"> • main switchboard(s) and emergency switchboard • main source of power including battery rooms, if any • emergency source of power and transitional source of power (where required by the applicable rules) • distribution boards supplying primary and secondary essential services • UPS or batteries serving primary and secondary essential services and emergency services • major equipment serving propulsion (e.g. motors, transformers, converter, etc.)
19	A	A functional diagram of uninterruptible power supply (UPS) for primary essential services, emergency services and 50kVA and over secondary essential services.	Reference is to be made to Sec 7, [3].
20	A	Plan of hazardous areas, where applicable	Reference is to be made to: <ul style="list-style-type: none"> - Sec 3, [10] and - service notations in relation to the type and/or service of the ship: <ul style="list-style-type: none"> • Pt E, Ch 1, Sec 4 for ro-ro cargo ships • Pt E, Ch 7, Sec 6 for oil tankers and fls tankers • Pt E, Ch 8, Sec 10 for chemical tankers • Pt E, Ch 9, Sec 10 for liquefied gas carrier • Pt E, Ch 12, Sec 5 for ro-ro passenger ships • Pt E, Ch 17, Sec 4 for oil recovery ships • Pt E, Ch 19, Sec 5 for barge oil-non propelled ship • Pt E, Ch 24, Sec 9 for Compressed Natural Gas Carrier • Pt E, Ch 25, Sec 6 for oil carrier-assisted propulsion • Pt E, Ch 26, Sec 5 for palm-oil carrier assisted propulsion • Pt E, Ch 28, Sec 4 for chemical recovery ship • Pt E, Ch 29, Sec 4 for well stimulation
DOCUMENTS REQUESTED IN RELATION TO THE TYPE AND SERVICES OF THE SHIP			
21	A	Diagram of alarm, monitoring and safety system of inert gas system, where applicable.	Reference is to be made to the requirements of Ch 4, Sec 1, [9]
22	A	Document giving certification details of types of cables and safety characteristics of the equipment installed in hazardous areas, as applicable.	Reference is to be made to Sec 3, [10].
23	A	Diagrams of tank level indicator systems, high level alarm systems and overflow control systems, where applicable.	Reference is to be made to the requirements of Pt E, Ch 7, Sec 4 and sec 5
24	A	Single line diagrams of the power supply to well stimulation equipment.	Reference is to be made to the requirements of Pt E, Ch 29, Sec 4.
(1) A: to be submitted for approval I: to be submitted for information			

No.	I/A (1)	Documents to be submitted	Notes
25	A	Electrical diagrams of power control and position indication circuits for bow doors, stern doors, side doors, inner doors, television system and alarm systems for ingress of water.	Reference is to be made to the requirements of Pt E, Ch 1, Sec 2; Pt E, Ch 11, Sec 3; Pt E, Ch 12, Sec 2, Ch 12, Sec 2.
26	A	Diagrams of the supplies to the supplementary emergency lighting systems for ro-ro passenger ships.	Reference is to be made to the requirements of Pt E, Ch 12, Sec 5, [2]
(1) A: to be submitted for approval I: to be submitted for information			

Table 2 : Documents requested in relation to the type and services of the ship (2) (1/7/2021)

No.	(1)	Documents to be submitted
1	A	Electrical diagram of the automatic fire detection and alarm systems and manually operated call points.
2	A	Electrical diagram of the fixed gas fire-extinguishing systems.
3	A	Electrical diagram of the sprinkler systems.
4	A	Electrical diagram of power control and position indication circuits for fire doors.
5	A	Diagram of the remote stop system (ventilation, fuel pumps, etc.).
6	A	Diagram of power, control and indication circuits for electrically operated low location lighting (LLL).
(1) A: to be submitted for approval (2) Reference is to be made to the requirements of "Rules for Fire Protection, Detection and Extinction for the Issue and Maintenance of SOLAS Certificates" or "Rules for Fire Protection, Detection and Extinction for the Issue and Maintenance of Statutory Certificates other than SOLAS Certificates", as applicable.		

3.3 Primary essential services

3.3.1 Primary essential services are those which need to be in continuous operation to maintain propulsion and steering.

Examples of equipment for primary essential services are the following:

- Steering gear
- Pumps for controllable pitch propellers
- Scavenging air blowers, fuel oil supply pumps, fuel valve cooling pumps, lubricating oil pumps and cooling water pumps for main and auxiliary engines and turbines necessary for the propulsion
- Forced draught fans, feed water pumps, water circulating pumps, condensate pumps, oil burning installations, for steam plants or steam turbines ship, and also for auxiliary boilers on ship where steam is used for equipment supplying primary essential services
- Azimuth thrusters which are the sole means for propulsion/steering with lubricating oil pumps, cooling water pumps
- Electrical equipment for electric propulsion plant with lubricating oil pumps and cooling water pumps
- Electric generators and associated power sources supplying the above equipment
- Hydraulic pumps supplying the above equipment
- Viscosity control equipment for heavy fuel oil
- Control, monitoring and safety devices/systems for equipment for primary essential services
- Speed regulators dependent on electrical energy for main or auxiliary engines necessary for propulsion.

The main lighting system for those parts of the ship normally accessible to and used by personnel and passengers is also considered (included as) a primary essential service.

3.4 Secondary essential services

3.4.1 Secondary essential services are those services which need not necessarily be in continuous operation to maintain propulsion and steering but which are necessary for maintaining the vessel's safety.

Examples of equipment for secondary essential services are the following:

- Windlasses
- Fuel oil transfer pumps and fuel oil treatment equipment
- Lubrication oil transfer pumps and lubrication oil treatment equipment
- Preheaters for heavy fuel oil
- Sea water pumps
- Starting air and control air compressors
- Bilge, ballast and heeling pumps
- Fire pumps and other fire-extinguishing medium pumps
- Ventilation fans for engine and boiler rooms
- Services considered necessary to maintain dangerous cargo in a safe condition
- Navigation lights, aids and signals
- Internal safety communication equipment
- Fire detection and alarm systems
- Electrical equipment for watertight closing appliances
- Electric generators and associated power supplying the above equipment
- Hydraulic pumps supplying the above equipment

- Control, monitoring and safety for cargo containment systems
- Control, monitoring and safety devices/systems for equipment for secondary essential services.

3.4.2 Services for habitability are those which need to be in operation to maintain the vessel's minimum comfort conditions for people on board.

Examples of equipment for maintaining conditions of habitability:

- Cooking
- Heating
- Domestic refrigeration
- Mechanical ventilation
- Sanitary and fresh water
- Electric generators and associated power sources supplying the above equipment.

3.5 Safety voltage

3.5.1 A voltage which does not exceed 50 V a.c. r.m.s. between conductors, or between any conductor and earth, in a circuit isolated from the supply by means such as a safety isolating transformer.

3.5.2 A voltage which does not exceed 50 V d.c. between conductors or between any conductor and earth in a circuit isolated from higher voltage circuits.

3.6 Low-voltage systems

3.6.1 Alternating current systems with rated voltages greater than 50 V r.m.s. up to 1000 V r.m.s. inclusive and direct current systems with a maximum instantaneous value of the voltage under rated operating conditions greater than 50 V up to 1500 V inclusive.

3.7 High-voltage systems

3.7.1 Alternating current systems with rated voltages greater than 1000 V r.m.s. and direct current systems with a maximum instantaneous value of the voltage under rated operating conditions greater than 1500 V.

3.8 Basic insulation

3.8.1 Insulation applied to live parts to provide basic protection against electric shock.

Note 1: Basic insulation does not necessarily include insulation used exclusively for functional purposes.

3.9 Supplementary insulation

3.9.1 Independent insulation applied in addition to basic insulation in order to provide protection against electric shock in the event of a failure of basic insulation.

3.10 Double insulation

3.10.1 Insulation comprising both basic insulation and supplementary insulation.

3.11 Reinforced insulation

3.11.1 A single insulation system applied to live parts, which provides a degree of protection against electric shock equivalent to double insulation.

Note 1: The term "single insulation system" does not imply that the insulation must be one homogeneous piece. It may comprise several layers which cannot be tested singly as supplementary or basic insulation.

3.12 Earthing

3.12.1 The earth connection to the general mass of the hull of the ship in such a manner as will ensure at all times an immediate discharge of electrical energy without danger.

3.13 Normal operational and habitable condition

3.13.1 *A condition under which the ship as a whole, the machinery, services, means and aids ensuring propulsion, ability to steer, safe navigation, fire and flooding safety, internal and external communications and signals, means of escape, and emergency boat winches, as well as the designed comfortable conditions of habitability are in working order and functioning normally.*

3.14 Emergency condition

3.14.1 *A condition under which any services needed for normal operational and habitable conditions are not in working order due to failure of the main source of electrical power.*

3.15 Main source of electrical power

3.15.1 *A source intended to supply electrical power to the main switchboard for distribution to all services necessary for maintaining the ship in normal operational and habitable condition.*

3.16 Dead ship condition

3.16.1 *The condition under which the main propulsion plant, boilers and auxiliaries are not in operation due to the absence of power.*

Note 1: Dead ship condition is a condition in which the entire machinery installation, including the power supply, is out of operation and the auxiliary services such as compressed air, starting current from batteries etc., for bringing the main propulsion into operation and for the restoration of the main power supply are not available.

3.17 Main generating station

3.17.1 *The space in which the main source of electrical power is situated.*

3.18 Main switchboard

3.18.1 *A switchboard which is directly supplied by the main source of electrical power and is intended to distribute electrical energy to the ship's services.*

3.19 Emergency switchboard

3.19.1 *A switchboard which in the event of failure of the main electrical power supply system is directly supplied by the emergency source of electrical power or the transitional source of emergency and is intended to distribute electrical energy to the emergency services.*

3.20 Emergency source of electrical power

3.20.1 *A source of electrical power, intended to supply the emergency switchboard in the event of failure of the supply from the main source of electrical power.*

3.21 Distribution board

3.21.1 (1/1/2021)

A switchgear and controlgear assembly which is supplied by the main or the emergency switchboard or distribution boards and is arranged for the distribution of electrical energy to other distribution boards, final distribution boards or final sub-circuits.

3.22 Final sub-circuit

3.22.1 That portion of a wiring system extending beyond the final required overcurrent protective device of a board.

3.23 Motor control centre (MCC)

3.23.1 (1/1/2021)

A switchgear and controlgear assembly which is supplied by main or emergency switchboards and is intended to control and distribute electrical energy.

Note 1: It is possible for the MCC to be a section or sections of the main switchboard.

3.24 Hazardous areas

3.24.1 Areas in which an explosive atmosphere is present, or may be expected to be present due to the presence of vapours, gases, flammable dusts or explosives in quantities such as to require special precautions for the construction, installation and use of electrical apparatus.

3.24.2 Hazardous areas are classified in zones based upon the frequency and the duration of the occurrence of explosive atmosphere.

3.24.3 (1/7/2022)

Hazardous areas for explosive gas atmosphere are classified in the following zones:

- Zone 0: an area in which ignitable concentrations of flammable gases or vapours are continuously present or present for long periods
- Zone 1: an area in which ignitable concentrations of flammable gases or vapours are likely to occur in normal operation
- Zone 2: an area in which ignitable concentrations of flammable gases or vapours are not likely to occur, or in which such a mixture, if it does occur, will exist for a short period only.

3.25 Certified safe-type equipment

3.25.1 Certified safe-type equipment is electrical equipment of a type for which a national or other appropriate authority has carried out the type verifications and tests necessary to certify the safety of the equipment with regard to explosion hazard when used in an explosive gas atmosphere.

3.26 Environmental categories

3.26.1 (1/7/2021)

Electrical equipment is classified into environmental categories according to the temperature range, vibration levels,

and resistance to chemically active substances and to humidity.

The designation of the environmental categories is indicated by the EC Code in Tab 3

The first characteristic numeral indicates the temperature range in which the electrical equipment operates satisfactorily, as specified in Tab 4

The second characteristic numeral indicates the vibration level in which the electrical equipment operates satisfactorily, as specified in Tab 5.

3.26.2 The tests for verifying the additional and supplementary letters and the characteristic numeral of the environmental categories are defined in Ch 3, Sec 8.

3.27 Navigation Light (NL)

3.27.1 (1/7/2015)

Navigation Light (NL) means the following lights:

- *masthead light, sidelights, sternlight, towing light, all-round light, flashing light as defined in Rule 21 of COLREGs (see Note 1),*
- *all-round flashing yellow light required for air-cushion vessels by Rule 23 of COLREGs,*
- *manoeuvring light required by Rule 34(b) of COLREGs.*

Note 1:

COLREGs means Convention on the International Regulations for Preventing Collisions at Sea, 1972, including their annexes.

Table 3 : EC Code

Code letter	First characteristic numeral	Second characteristic numeral	Additional letter	Supplementary letter
EC	(numerals 1 to 4)	(numerals 1 to 3)	(letter S) (1)	(letter C) (2)
(1) The additional letter S indicates the resistance to salt mist (exposed decks, masts) of the electrical equipment.				
(2) The supplementary letter C indicates the relative humidity up to 80% (air conditioned areas) in which the electrical equipment operates satisfactorily.				

Table 4 : First characteristic numeral (1/7/2017)

First characteristic numeral	Brief description of location	Temperature range °C	
1	Air conditioned areas	+ 5	+ 40
2	Enclosed spaces	+ 5	+ 45
3a	Electronic equipment inside consoles, housing, etc..	+ 5	+ 55
3b	Close to combustion engines, boilers and similar	+ 5	+ 70
4	Exposed decks, masts	- 25	+ 45

Table 5 : Second characteristic numeral

Second characteristic numeral	Brief description of location	Frequency range Hz	Displacement amplitude mm	Acceleration amplitude g
1	Machinery spaces, command and control stations, accommodation spaces, exposed decks, cargo spaces	from 2,0 to 13,2 from 13,2 to 100	1,0 -	- 0,7
2	Masts	from 2,0 to 13,2 from 13,2 to 50	3,0 -	- 2,1
3	On air compressors, on diesel engines and similar	from 2,0 to 25,0 from 25,0 to 100	1,6 -	- 4,0

SECTION 2

GENERAL DESIGN REQUIREMENTS

1 Environmental conditions

1.1 General

1.1.1 The electrical components of installations are to be designed and constructed to operate satisfactorily under the environmental conditions on board.

In particular, the conditions shown in the tables in this Article are to be taken into account.

Note 1: The environmental conditions are characterised by:

- one set of variables including climatic conditions (e.g. ambient air temperature and humidity), biological conditions, conditions dependent upon chemically active substances (e.g. salt mist) or mechanically active substances (e.g. dust or oil), mechanical conditions (e.g. vibrations or inclinations) and conditions dependent upon electromagnetic noise and interference, and
- another set of variables dependent mainly upon location on vessels, operational patterns and transient conditions.

1.2 Ambient air temperatures

1.2.1 (1/7/2017)

For ships classed for unrestricted navigation, the reference ambient air temperature ranges are shown in Tab 1 in relation to the various locations of installation.

1.2.2 (1/7/2006)

Where electrical equipment is installed within environmentally controlled spaces, the ambient temperature for which the equipment is to be suitable may be reduced from 45° and maintained at a value not less than 35° provided:

- the equipment is not for use for emergency services.
- temperature control is achieved by at least two cooling units so arranged that in the event of loss of one cooling unit, for any reason, the remaining unit(s) is (are) capable of satisfactorily maintaining the design temperature.
- the equipment is able to be initially set to work safely up to a 45° ambient temperature until such time as the lower ambient temperature is achieved; the cooling equipment is to be rated for a 45° ambient temperature.
- audible and visual alarms are fitted, at a continually manned control station, to indicate any malfunction of the cooling units.

1.2.3 (1/7/2004)

In accepting an ambient temperature less than 45° it is to be ensured that electrical cables are adequately rated throughout their length for the maximum ambient temperature to which they are exposed.

1.2.4 (1/7/2004)

The equipment used for cooling and maintaining the lower ambient temperature is to be classified for a secondary essential service.

1.2.5 For ships classed for service in specific zones, the Society may accept different ambient air temperature (e.g. for ships operating outside the tropical belt, the maximum ambient air temperature may be assumed as equal to + 40 °C instead of + 45 °C).

Table 1 : Ambient air temperature (1/7/2017)

Location	Temperature range, in °C	
Enclosed spaces	+ 5	+ 45
Electronic equipment inside console, housing, etc.	+ 5	+ 55
Fitted on combustion engines, boilers and similar	+ 5	+ 70
Exposed decks	- 25	+ 45

1.3 Humidity

1.3.1 For ships classed for unrestricted service, the humidity ranges shown in Tab 2 are applicable in relation to the various locations of installation.

Table 2 : Humidity

Location	Humidity
General	95% at 55 °C
Air conditioned areas	Different values may be considered on a case by case basis

1.4 Cooling water temperatures

1.4.1 The temperatures shown in Tab 3 are applicable to ships classed for unrestricted service.

1.4.2 For ships classed for service in specific zones, the Society may accept different values for the cooling water temperature (e.g. for ships operating outside the tropical belt, the maximum cooling water temperature may be assumed as equal to + 25 °C instead of + 32 °C).

Table 3 : Water temperature

Coolant	Temperature range, in °C	
Sea water	0	+ 32

1.5 Salt mist

1.5.1 The applicable salt mist content in the air is to be 1 mg/m³.

1.6 Inclinations

1.6.1 The inclinations applicable are those shown in Tab 4.

The Society may consider deviations from these angles of inclination taking into consideration the type, size and service conditions of the ships.

1.7 Vibrations

1.7.1 In relation to the location of the electrical components, the vibration levels given in Tab 5 are to be assumed.

1.7.2 The natural frequencies of the equipment, their suspensions and their supports are to be outside the frequency ranges specified.

Where this is not possible using a suitable constructional technique, the equipment vibrations are to be dumped so as to avoid unacceptable amplifications.

2 Quality of power supply

2.1 Voltage and frequency variation

2.1.1 (1/7/2006)

All electrical appliances supplied from the main or emergency systems are to be so designed and manufactured that they are capable of operating satisfactorily under the normally occurring variations in voltage and frequency.

2.1.2 (1/7/2006)

Unless otherwise stated in national or international standards, all equipment is to operate satisfactorily with the vari-

ations from its rated value shown in Tab 6 to Tab 8 subject to the following conditions.

- For alternating current components, the voltage and frequency variations shown in Tab 6 are to be assumed.
- For direct current components supplied by d.c. generators or converted by rectifiers, the voltage variations shown in Tab 7 are to be assumed.
- For direct current components supplied by electrical batteries, the voltage variations shown in Tab 8 are to be assumed.

2.1.3 (1/7/2007)

Any special system, e.g. electronic circuits, whose function cannot operate satisfactorily within the limits shown in Tab 6, Tab 7 and Tab 8 is not to be supplied directly from the system but by alternative means, e.g. through stabilised supply.

2.2 Harmonic distortions

2.2.1 For components intended for systems without substantially static converter loads and supplied by synchronous generators, it is assumed that the total voltage harmonic distortion does not exceed 5%, and the single harmonic does not exceed 3% of the nominal voltage.

2.2.2 For components intended for systems fed by static converters, and/or systems in which the static converter load predominates, it is assumed that:

- the single harmonics do not exceed 5% of the nominal voltage up to the 15th harmonic of the nominal frequency, decreasing to 1% at the 100th harmonic (see Fig 1), and that
- the total harmonic distortion does not exceed 10%.

Table 4 : Inclination of ship (1/7/2021)

Type of machinery, equipment or component	Angles of inclination, in degrees (1)			
	Athwartship		Fore-and-aft	
	static	dynamic (4)	static	dynamic (5)
Machinery and equipment relative to main electrical power installation	15	22,5	5	7,5
Machinery and equipment relative to the emergency power installation and crew and passenger safety systems of the ship (e.g. emergency source of power, emergency fire pumps, etc.)	22,5 (2)	22,5 (2)	10	10
Switchgear and associated electrical and electronic components and remote control systems (3)	22,5	22,5	10	10

(1) Athwartship and fore-and-aft angles may occur simultaneously in their most unfavourable combination.
(2) In the case of gas carriers or chemical tankers, the emergency power supply must also remain operable with the ship flooded to a final athwartship inclination up to a maximum of 30°.
(3) No undesired switching operations or functional changes are to occur.
(4) The period of dynamic inclination may be assumed equal to 10 s.
(5) The period of dynamic inclination may be assumed equal to 5 s.

Table 5 : Vibration levels

Location	Frequency range Hz	Displacement amplitude mm	Acceleration amplitude g
Machinery spaces, command and control stations, accommodation spaces, exposed decks, cargo spaces	from 2,0 to 13,2 from 13,2 to 100	1,0 -	- 0,7
On air compressors, on diesel engines and similar	from 2,0 to 25,0 from 25,0 to 100	1,6 -	- 4,0
Masts	from 2,0 to 13,2 from 13,2 to 50	3,0 -	- 2,1

Figure 1

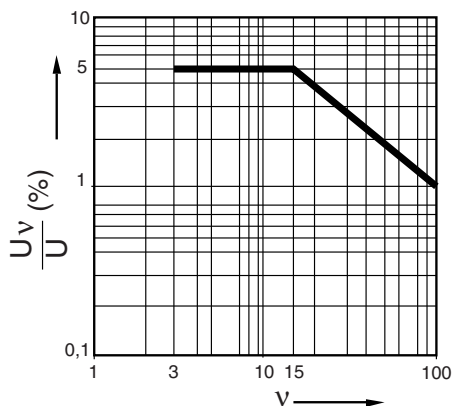

Table 6 : Voltage and frequency variations for a.c. distribution systems (1/7/2004)

Quantity in operation	Variations	
	Continuous	Transient
Voltage	+ 6% - 10%	± 20% (recovery time: 1,5 s)
Frequency	± 5%	± 10% (recovery time: 5 s)

Table 7 : Voltage variations for d.c. distribution systems

Parameters	Variations
Voltage tolerance (continuous)	± 10%
Voltage cyclic variation deviation	5%
Voltage ripple (a.c. r.m.s. over steady d.c. voltage)	10%

2.2.3 (1/7/2017)

Where harmonic filters are fitted onboard, e.g. in electric propulsion plant systems, the total harmonic distortion (THD) of electrical distribution systems is not to exceed 8%. This limit may be exceeded where all installed equipment and systems have been designed for a higher specified limit and this relaxation on limits is to be documented (harmonic distortion calculation report) and made available onboard as a reference for the surveyor in charge for survey.

Note 1: installation where harmonic filters are installed for single application frequency drives such as pump motors, are exclude from the application of this requirement.

Table 8 : Voltage variations for battery systems (1/7/2006)

Systems	Variations
Components connected to the battery during charging (1)	+30%, -25%
Components not connected to the battery during charging	+20%, -25%
(1) Different voltage variations as determined by the charging/discharging characteristics, including ripple voltage from the charging device, may be considered.	

3 Electromagnetic susceptibility

3.1

3.1.1 For electronic type components such as sensors, alarm panels, automatic and remote control equipment, protective devices and speed regulators, the conducted and radiated disturbance levels to be assumed are those given in Chapter 3.

Note 1: See also IEC Publication 60533 - "Electromagnetic Compatibility of Electrical and Electronic Installations in Ships and of Mobile and Fixed Offshore Units".

4 Materials

4.1 General

4.1.1 In general, and unless it is adequately protected, all electrical equipment is to be constructed of durable, flame-retardant, moisture-resistant materials which are not subject to deterioration in the atmosphere and at the temperatures to which they are likely to be exposed. Particular consideration is to be given to sea air and oil vapour contamination.

Note 1: The flame-retardant and moisture-resistant characteristics may be verified by means of the tests cited in IEC Publication 60092-101 or in other recognised standards.

4.1.2 Where the use of incombustible materials or lining with such materials is required, the incombustibility characteristics may be verified by means of the test cited in IEC Publication 60092-101 or in other recognised standards.

4.2 Insulating materials for windings

4.2.1 Insulated windings are to be resistant to moisture, sea air and oil vapour unless special precautions are taken to protect insulants against such agents.

4.2.2 (1/7/2006)

The insulation classes given in Tab 9 may be used.

Table 9 : Insulation Classes

Class	Maximum continuous operating temperature °C
A	105
E	120
B	130
F	155
H	180

4.3 Insulating materials for cables

4.3.1 See Sec 9, [1.3].

5 Construction

5.1 General

5.1.1 All electrical apparatus is to be so constructed as not to cause injury when handled or touched in the normal manner.

5.1.2 The design of electrical equipment is to allow accessibility to each part that needs inspection or adjustment, also taking into account its arrangement on board.

5.1.3 Enclosures are to be of adequate mechanical strength and rigidity.

5.1.4 Enclosures for electrical equipment are generally to be of metal; other materials may be accepted for accessories such as connection boxes, socket-outlets, switches and luminaires. Other exemptions for enclosures or parts of enclosures not made of metal will be specially considered by the Society.

5.1.5 Cable entrance are not to impair the degree of protection of the relevant enclosure (see Sec 3, Tab 2).

5.1.6 All nuts and screws used in connection with current-carrying parts and working parts are to be effectively locked.

5.1.7 All equipment is generally to be provided with suitable, fixed terminal connectors in an accessible position for convenient connection of the external cables.

5.2 Degree of protection of enclosures

5.2.1 Electrical equipment is to be protected against the ingress of foreign bodies and water.

The minimum required degree of protection, in relation to the place of installation, is generally that specified in Sec 3, Tab 2.

5.2.2 The degrees of protection are to be in accordance with:

- IEC Publication No. 60529 for equipment in general
- IEC Publication No. 60034-5 for rotating machines.

5.2.3 For cable entries see [4.3.1].

6 Protection against explosion hazard

6.1 Protection against explosive gas or vapour atmosphere hazard

6.1.1 Electrical equipment intended for use in areas where explosive gas or vapour atmospheres may occur (e.g. oil tankers, liquefied gas carriers, chemical tankers, etc.), is to be of a "safe type" suitable for the relevant flammable atmosphere and for shipboard use.

6.1.2 The following "certified safe type" equipment is considered:

- intrinsically-safe: Ex(ia) - Ex(ib)
- flameproof: Ex(d)
- increased safety: Ex(e)
- pressurised enclosure: Ex(p)
- encapsulated: Ex(m)
- sand filled: Ex(q)
- special protection: Ex(s)
- oil-immersed apparatus (see Note 1): Ex(o)

Note 1: Only when required by the application.

6.1.3 Other equipment complying with types of protection other than those in [6.1.2] may be considered by the Society, such as:

- simple electrical apparatus and components (e.g. thermocouples, photocells, strain gauges, junction boxes, switching devices), included in intrinsically-safe circuits not capable of storing or generating electrical power or energy in excess of limits stated in the relevant rules
- electrical apparatus specifically designed and certified by the appropriate authority for use in Zone 0 or specially tested for Zone 2 (e.g. type "n" protection)
- equipment the type of which ensures the absence of sparks and arcs and of "hot spots" during its normal operation
- pressurised equipment
- equipment having an enclosure filled with a liquid dielectric, or encapsulated.

6.2 Protection against combustible dust hazard

6.2.1 Electrical appliances intended for use in areas where a combustible dust hazard may be present are to be

arranged with enclosures having a degree of protection and maximum surface temperature suitable for the dust to which they may be exposed.

Note 1: Where the characteristics of the dust are unknown, the appliances are to have a degree of protection IP6X. For most dusts a maximum surface temperature of 200°C is considered adequate.

SECTION 3

SYSTEM DESIGN

1 Supply systems and characteristics of the supply

1.1 Supply systems

1.1.1 The following distribution systems may be used:

- a) on d.c. installations:
 - two-wire insulated
 - two-wire with one pole earthed
- b) on a.c. installations:
 - three-phase three-wire with neutral insulated
 - three-phase three-wire with neutral directly earthed or earthed through an impedance
 - three-phase four-wire with neutral directly earthed or earthed through an impedance
 - single-phase two-wire insulated
 - single-phase two-wire with one phase earthed.

1.1.2 Distribution systems other than those listed in [1.1.1] (e.g. with hull return, three-phase four-wire insulated) will be considered by the Society on a case by case basis.

1.1.3 The hull return system of distribution is not to be used for power, heating or lighting in any ship of 1600 tons gross tonnage and upwards.

1.1.4 The requirement of [1.1.3] does not preclude under conditions approved by the Society the use of:

- a) impressed current cathodic protective systems,
- b) limited and locally earthed systems, or
- c) insulation level monitoring devices provided the circulation current does not exceed 30 mA under the most unfavourable conditions.

Note 1: Limited and locally earthed systems such as starting and ignition systems of internal combustion engines are accepted provided that any possible resulting current does not flow directly through any dangerous spaces.

1.1.5 For the supply systems of ships carrying liquid developing combustible gases or vapours, see Pt E, Ch 7, Sec 5, Pt E, Ch 8, Sec 10 or Pt E, Ch 9, Sec 10.

1.1.6 For the supply systems in HV Installations, see Sec 13.

1.2 Maximum voltages

1.2.1 The maximum voltages for both alternating current and direct current low-voltage systems of supply for the ship's services are given in Tab 1.

Table 1 : Maximum voltages for various ship services

Use		Maximum voltage, in V
For permanently installed and connected to fixed wiring	Power equipment	1000
	Heating equipment (except in accommodation spaces)	500
	Cooking equipment	500
	Lighting	250
	Space heaters in accommodation spaces	250
	Control (1) , communication (including signal lamps) and instrumentation equipment	250
For permanently installed and connected by flexible cable	Power and heating equipment, where such connection is necessary because of the application (e.g. for moveable cranes or other hoisting gear)	1000
For socket-outlets supplying	Portable appliances which are not hand-held during operation (e.g. refrigerated containers) by flexible cables	1000
	Portable appliances and other consumers by flexible cables	250
	Equipment requiring extra precaution against electric shock where an isolating transformer is used to supply one appliance (2)	250
	Equipment requiring extra precaution against electric shock with or without a safety transformer (2) .	50
(1) For control equipment which is part of a power and heating installation (e.g. pressure or temperature switches for starting/stopping motors), the same maximum voltage as allowed for the power and heating equipment may be used provided that all components are constructed for such voltage. However, the control voltage to external equipment is not to exceed 500 V.		
(2) Both conductors in such systems are to be insulated from earth.		

1.2.2 Voltages exceeding those shown will be specially considered in the case of specific systems.

1.2.3 For high voltage systems see Sec 13.

2 Sources of electrical power

2.1 General

2.1.1 *Electrical installations are to be such that:*

- a) *All electrical auxiliary services necessary for maintaining the ship in normal operational and habitable conditions and for the preservation of the cargo will be assured without recourse to the emergency source of electrical power.*
- b) *Electrical services essential for safety will be assured under various emergency conditions.*
- c) When a.c. generators are involved, attention is to be given to the starting of squirrel-cage motors connected to the system, particularly with regard to the effect of the magnitude and duration of the transient voltage change produced due to the maximum starting current and the power factor. The voltage drop due to such starting current is not to cause any motor already operating to stall or have any adverse effect on other equipment in use.

2.2 Main source of electrical power

2.2.1 *A main source of electrical power is to be provided, of sufficient capability to supply all electrical auxiliary services necessary for maintaining the ship in normal operational and habitable conditions and for the preservation of the cargo without recourse to the emergency source of electrical power.*

2.2.2 For ships propelled by electrical power and having two or more constant voltage propulsion generating sets which constitute the source of electrical energy for the ship's auxiliary services, see Sec 14.

2.2.3 (1/7/2019)

The main source of electrical power is to consist of at least two generating sets.

The capacity of these generating sets is to be such that in the event of any one generating set being stopped it will still be possible to supply those services necessary to provide:

- a) normal operational conditions of propulsion and safety (see [2.2.4])
- b) minimum comfortable conditions of habitability (see Sec 1, [3.4.2])
- c) preservation of the cargo.

Such capacity is, in addition, to be sufficient to start the largest motor without causing any other motor to stop or having any adverse effect on other equipment in operation.

Note 1: for ships having navigation notation "sheltered area" or "special navigation" having an area of operation at not more than 6 miles from the shore (see Sec 1, [1.1.3]) and not subject to the SOLAS convention, the Society may accept that:

- the main source of electrical power consists of one generator (which may have the ship's propulsion machinery as prime mover), and one accumulator battery, provided that the capacity of the accumulator battery is sufficient to supply, without being recharged, all essential services for not less than 1.2 times the expected duration of the longest voyage, but not less than:
 - 5 hours, or
 - 30 minutes for ships having navigation notation "sheltered area",
- the main switchboard is supplied by only one cable by main generator and accumulator battery provided that main generator and accumulator battery are individually protected against short-circuit and overload.

2.2.4 Those services necessary to provide normal operational conditions of propulsion and safety include primary and secondary essential services.

For the purpose of calculating the capacity necessary for such services, it is essential to consider which of them can be expected to be in use simultaneously.

For a duplicated service, one being supplied electrically and the other non-electrically (e.g. driven by the main engine), the electrical capacity is not included in the above calculation.

2.2.5 The services in [2.2.4] do not include:

- thrusters not forming part of the main propulsion
- cargo handling gear
- cargo pumps
- refrigerators for air conditioning.

2.2.6 *Further to the provisions above, the generating sets shall be such as to ensure that with any one generator or its primary source of power out of operation, the remaining generating sets shall be capable of providing the electrical services necessary to start the main propulsion plant from a "dead ship" condition.*

2.2.7 *The emergency source of electrical power may be used for the purpose of starting from a "dead ship" condition if its capability either alone or combined with that of any other source of electrical power is sufficient to provide at the same time those services required to be supplied in accordance with the provisions of [3.7.3] (items a, b, c, d) or Pt E, Ch 11, Sec 5 for passenger ships.*

2.2.8 *The arrangement of the ship's main source of electrical power shall be such that essential services can be maintained regardless of the speed and direction of rotation of the main propulsion machinery or shafting.*

2.2.9 Generators driven by the propulsion plant (shaft generators) which are intended to operate at constant speed (e.g. a system where vessel speed and direction are controlled by varying propeller pitch) may be accepted as forming part of the main source of electrical power if, in all sailing and manoeuvring conditions including the propeller being stopped, the capacity of these generators is sufficient to provide the electrical power to comply with [2.2.3] and all further requirements, especially those of [2.2.6]. They are to be not less effective and reliable than the independent generating sets.

2.2.10 (1/7/2022)

Generators and generator systems, having the ship's propulsion machinery as their prime mover but not forming part of the ship's main source of electrical power (see Note 1) may be used whilst the ship is at sea to supply electrical services required for normal operational and habitable conditions, provided that:

- there are sufficient and adequately rated additional generators fitted, which constitute the main source of electrical power required by [2.2.1], meeting the provisions of [2.2.8]
- arrangements are fitted to automatically start one or more of the generators constituting the main source of electrical power required by [2.2.1], in compliance with [3.4.5] and also in the event of frequency variations exceeding $\pm 10\%$ of the limits specified below
- within the declared operating range of the generators and/or generator systems, the specified limits for the voltage variations in IEC 60092-301/AMD2 and the frequency variations in Sec 2, Tab 6 can be met
- the short-circuit current of the generator and/or generator system is sufficient to trip the generator/generator system circuit-breaker taking into account the selectivity of the protective devices for the distribution system
- where considered appropriate, load shedding arrangements are fitted to meet the requirements of [3.4.6], [3.4.7] and [3.4.8]
- on ships having remote control of the propulsion machinery from the navigating bridge, means are provided or procedures are in place so as to ensure that supplies to essential services are maintained during

manoeuvring conditions in order to avoid a blackout situation (see Note 2).

Note 1: Such generator systems are those whose operation does not meet the requirements of IEC 60092-201, paragraph 8.1.1.

Note 2: A 'blackout situation' means that the main and auxiliary machinery installations, including the main power supply, are out of operation but the services for bringing them into operation (e.g. compressed air, starting current from batteries etc.) are available.

2.2.11 (1/7/2006)

Where transformers, converters or similar appliances constitute an essential part of the electrical supply system, the system is to be so arranged as to ensure the same continuity of supply as stated in this sub-article [2.2].

This may be achieved by arranging at least two three-phase or three single-phase transformers supplied, protected and installed as indicated in Fig 1, so that with any one transformer not in operation, the remaining transformer(s) is (are) sufficient to ensure the supply to the services stated in [2.2.3].

Each transformer required is to be located as a separate unit with separate enclosure or equivalent, and is to be served by separate circuits on the primary and secondary sides. Each of the primary circuits is to be provided with switchgears and protection devices in each phase. Each of the secondary circuits is to be provided with a multiple isolating switch.

Suitable interlocks or a warning label are to be provided in order to prevent maintenance or repair of one single-phase transformer unless both switchgears are opened on their primary and secondary sides.

2.2.12 For ships intended for operation with periodically unattended machinery spaces, see Part F, Chapter 3.

2.2.13 For starting arrangements for main generating sets, see Ch 1, Sec 2, [5.1].

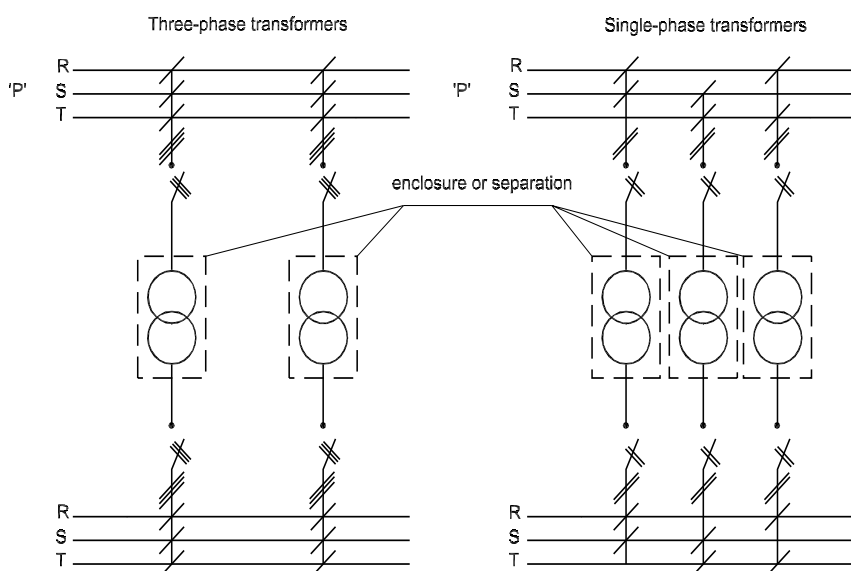
Figure 1

2.3 Emergency source of electrical power

2.3.1 *A self-contained emergency source of electrical power shall be provided.*

2.3.2 *Provided that suitable measures are taken for safeguarding independent emergency operation under all circumstances, the emergency generator may be used, exceptionally, and for short periods, to supply non-emergency circuits.*

Exceptionally is understood to mean conditions, while the vessel is at sea, such as:

- a) blackout situation
- b) dead ship situation
- c) routine use for testing
- d) short-term parallel operation with the main source of electrical power for the purpose of load transfer.

Unless otherwise instructed by the Society, the emergency generator may be used during lay time in port for the supply of the ship mains, provided the requirements of [2.4] are complied with.

2.3.3 *The electrical power available shall be sufficient to supply all those services that are essential for safety in an emergency, due regard being paid to such services as may have to be operated simultaneously.*

2.3.4 *The emergency source of electrical power shall be capable, having regard to starting currents and the transitory nature of certain loads, of supplying simultaneously at least the services stated in [3.7.3] for the period specified, if they depend upon an electrical source for their operation.*

2.3.5 *The transitional source of emergency electrical power, where required, is to be of sufficient capacity to supply at least the services stated in [3.7.7] for half an hour, if they depend upon an electrical source for their operation.*

2.3.6 *An indicator shall be mounted in a suitable place on the main switchboard or in the machinery control room to indicate when the batteries constituting either the emergency source of electrical power or the transitional source of emergency electrical power referred to in [2.3.13] and [2.3.14] are being discharged.*

2.3.7 If the services which are to be supplied by the transitional source receive power from an accumulator battery by means of semiconductor convertors, means are to be provided for supplying such services also in the event of failure of the convertor (e.g. providing a bypass feeder or a duplication of convertor).

2.3.8 (1/7/2002)

Where electrical power is necessary to restore propulsion, the capacity of the emergency source shall be sufficient to restore propulsion to the ship in conjunction to other machinery as appropriate, from a dead ship condition within 30 min. after blackout.

For the purpose of this requirement only, the dead ship condition and blackout are both understood to mean a condition under which the main propulsion plant, boilers

and auxiliaries are not in operation and in restoring the propulsion, no stored energy for starting the propulsion plant, the main source of electrical power and other essential auxiliaries is to be assumed available. It is assumed that means are available to start the emergency generator at all times.

The emergency generator and other means needed to restore the propulsion are to have a capacity such that the necessary propulsion starting energy is available within 30 minutes of blackout/dead ship condition as defined above. Emergency generator stored starting energy is not to be directly used for starting the propulsion plant, the main source of electrical power and/or other essential auxiliaries (emergency generator excluded).

For steam ships, the 30 minute time limit given in SOLAS Convention can be interpreted as time from blackout/dead ship condition defined above to light-off the first boiler.

For passenger ships not engaged in international voyages and cargo ships of less than 500 gross tonnage or of 500 gross tonnage and upwards not engaged in international voyages, the 30 minute time limit does not apply.

2.3.9 *Provision shall be made for the periodic testing of the complete emergency system and shall include the testing of automatic starting arrangements, where provided.*

2.3.10 For starting arrangements for emergency generating sets, see Ch 1, Sec 2, [5.1].

2.3.11 *The emergency source of electrical power may be either a generator or an accumulator battery which shall comply with the requirements of [2.3.12] or [2.3.13], respectively.*

2.3.12 *Where the emergency source of electrical power is a generator, it shall be:*

- a) *driven by a suitable prime mover with an independent supply of fuel, having a flashpoint (closed cup test) of not less than 43°C;*
- b) *started automatically upon failure of the main source of electrical power supply to the emergency switchboard unless a transitional source of emergency electrical power in accordance with (c) below is provided; where the emergency generator is automatically started, it shall be automatically connected to the emergency switchboard; those services referred to in [3.7.7] shall then be connected automatically to the emergency generator; and*
- c) *provided with a transitional source of emergency electrical power as specified in [2.3.14] unless an emergency generator is provided capable both of supplying the services mentioned in that paragraph and of being automatically started and supplying the required load as quickly as is safe and practicable subject to a maximum of 45 s.*

2.3.13 *Where the emergency source of electrical power is an accumulator battery it shall be capable of:*

- a) *carrying the emergency electrical load without recharging while maintaining the voltage of the battery*

throughout the discharge period within 12% above or below its nominal voltage;

- b) automatically connecting to the emergency switchboard in the event of failure of the main source of electrical power; and
- c) immediately supplying at least those services specified in [3.7.7].

2.3.14 The transitional source of emergency electrical power where required by [2.3.12] (item c) shall consist of an accumulator battery which shall operate without recharging while maintaining the voltage of the battery throughout the discharge period within 12% above or below its nominal voltage and be so arranged as to supply automatically in the event of failure of either the main or the emergency source of electrical power for half an hour at least the services in [3.7.7] if they depend upon an electrical source for their operation.

2.3.15 For the emergency source of electrical power in passenger ships, see Pt E, Ch 11, Sec 5.

2.3.16 (1/1/2022)

When the emergency generator room ventilation system is fitted with closable ventilation louvers and ventilator closing appliances, the following requirements apply:

- a) ventilation louvers and closing appliances may either be hand-operated or power-operated (hydraulic / pneumatic / electric) and are to be operable under a fire condition;
- b) hand-operated ventilation louvers and closing appliances are to be kept open during normal operation of the vessel. Corresponding instruction plates are to be provided at the location where hand-operation is provided;
- c) power-operated ventilation louvers and closing appliances are to be of a fail-to-open type. Closed power-operated ventilation louvers and closing appliances are acceptable during normal operation of the vessel;
- d) power-operated ventilation louvers and closing appliances are to open automatically whenever the emergency generator is starting / in operation;
- e) it is to be possible to close ventilation openings by a manual operation from a clearly marked safe position outside the space, where the closing operation can be easily confirmed. The louver status (open / closed) shall be indicated at this position. Such closing shall not be possible from any other remote position.

2.4 Use of emergency generator in port

2.4.1 To prevent the generator or its prime mover from becoming overloaded when used in port, arrangements are to be provided to shed sufficient non-emergency loads to ensure its continued safe operation.

2.4.2 The prime mover is to be arranged with fuel oil filters and lubrication oil filters, monitoring equipment and protection devices as requested for the prime mover for main power generation and for unattended operation.

2.4.3 The fuel oil supply tank to the prime mover is to be provided with a low level alarm, arranged at a level ensuring sufficient fuel oil capacity for the emergency services for the period of time as required in [3.7].

2.4.4 The prime mover is to be designed and built for continuous operation and should be subjected to a planned maintenance scheme ensuring that it is always available and capable of fulfilling its role in the event of an emergency at sea.

2.4.5 Fire detectors are to be installed in the location where the emergency generator set and emergency switchboard are installed.

2.4.6 Means are to be provided to readily change over to emergency operation.

2.4.7 Control, monitoring and supply circuits for the purpose of the use of the emergency generator in port are to be so arranged and protected that any electrical fault will not influence the operation of the main and emergency services.

When necessary for safe operation, the emergency switchboard is to be fitted with switches to isolate the circuits.

2.4.8 Instructions are to be provided on board to ensure that, even when the vessel is underway, all control devices (e.g. valves, switches) are in a correct position for the independent emergency operation of the emergency generator set and emergency switchboard.

These instructions are also to contain information on the required fuel oil tank level, position of harbour/sea mode switch, if fitted, ventilation openings, etc.

3 Distribution

3.1 Earthed distribution systems

3.1.1 System earthing is to be effected by means independent of any earthing arrangements of the non-current-carrying parts.

3.1.2 Means of disconnection are to be fitted in the neutral earthing connection of each generator so that the generator may be disconnected for maintenance or insulation resistance measurements.

3.1.3 Generator neutrals may be connected in common, provided that the third harmonic content of the voltage wave form of each generator does not exceed 5%.

3.1.4 Where a switchboard is split into sections operated independently or where there are separate switchboards, neutral earthing is to be provided for each section or for each switchboard. Means are to be provided to ensure that the earth connection is not removed when generators are isolated.

3.1.5 Where for final sub-circuits it is necessary to locally connect a pole (or phase) of the sub-circuits to earth after the protective devices (e.g. in automation systems or to avoid electromagnetic disturbances), provision (e.g.

d.c./d.c. convertors or transformers) is to be made such that current unbalances do not occur in the individual poles or phases.

3.1.6 For high voltage systems see Sec 13.

3.2 Insulated distribution systems

3.2.1 *Every insulated distribution system, whether primary or secondary (see Note 1), for power, heating or lighting, shall be provided with a device capable of continuously monitoring the insulation level to earth (i.e. the values of electrical insulation to earth) and of giving an audible and visual indication of abnormally low insulation values.*

Note 1: A primary system is one supplied directly by generators. Secondary systems are those supplied by transformers or convertors.

3.2.2 For high voltage systems see Sec 13.

3.3 Distribution systems with hull return

3.3.1 *Where the hull return system is used, if permitted, all final sub-circuits, i.e. all circuits fitted after the last protective device, shall be two-wire.*

The hull return is to be achieved by connecting to the hull one of the busbars of the distribution board from which the final sub-circuits originate.

3.4 General requirements for distribution systems

3.4.1 The distribution system is to be such that the failure of any single circuit will not endanger or impair primary essential services and will not render secondary essential services inoperative for longer periods.

3.4.2 No common switchgear (e.g. contactors for emergency stop) is to be used between the switchboard's busbars and two primary non duplicated essential services.

3.4.3 *Where the main source of electrical power is necessary for propulsion and steering of the ship, the system shall be so arranged that the electrical supply to equipment necessary for propulsion and steering and to ensure safety of the ship will be maintained or immediately restored in the case of loss of any one of the generators in service.*

3.4.4 (1/1/2001)

Where the electrical power is normally supplied by more than one generator set simultaneously in parallel operation, provision of protection, including automatic disconnection of sufficient non-essential services and if necessary secondary essential services and those provided for habitability, are to be made to ensure that, in case of loss of any of these generating sets, the remaining ones are kept in operation to permit propulsion and steering and to ensure safety.

3.4.5 (1/1/2001)

Where the electrical power is normally supplied by one generator, provision are to be made, upon loss of power,

for automatic starting and connecting to the main switchboard of stand-by generator(s) of sufficient capacity with automatic restarting of the essential auxiliaries, in sequential operation if required. Starting and connection to the main switchboard of one generator is to be as rapid as possible, preferably within 30 seconds after loss of power.

Where prime movers with longer starting time are used, this starting and connection time may be exceeded upon approval from the Society.

3.4.6 (1/1/2001)

Load shedding or other equivalent arrangements are to be provided to protect the generators against sustained overload.

3.4.7 (1/1/2001)

The load shedding is to be automatic.

3.4.8 (1/1/2001)

The non-essential services, service for habitable conditions may be shed and, where necessary, additionally, the secondary essential services, sufficient to ensure the connected generator set or generator sets are not overloaded.

3.5 Harmonic distortion for ship electrical distribution system including harmonic filters

3.5.1 Monitoring of harmonic distortion levels for ships including harmonic filters (1/1/2020)

For ships where harmonic filters are installed on main busbars of electrical distribution system facilities to continuously monitor the levels of harmonic distortion experienced on the main busbar, as well as alerting the crew should the level of harmonic distortion exceed the acceptable limits, are to be fitted.

Where the engine room is provided with automation systems, the reading should be logged electronically, otherwise the reading is to be recorded in the engine log book for inspection by the surveyor.

3.5.2 Protection arrangements for harmonic filters (1/1/2020)

The harmonic filters should be arranged as three phase units with individual protection of each phase.

The activation of the protection arrangement in a single phase is to result in automatic disconnection of the complete filter.

Additionally, a current unbalance detection system, independent of the overcurrent protection, alerting the crew in case of current unbalance, is to be provided.

Arrangements are to be provided to alert the crew in the event of activation of the protection of a harmonic filter circuit.

Consideration is to be given to additional protection for the individual capacitor element as e.g. relief valve or overpressure disconnecter in order to protect against damage from rupturing; this consideration should take into account the type of capacitors used.

3.5.3 Mitigation of the effects of harmonic filter failure on a ship's operation (1/1/2020)

The system integrator of the distribution system is to show, by calculation, the effect of a failure of a harmonic filter on the level of harmonic distortion experienced.

The system integrator of the distribution system is to provide the ship Owner with guidance documenting permitted modes of operation of the electrical distribution system while maintaining harmonic distortion levels within acceptable limits during normal operation as well as following the failure of any combination of harmonic filters.

The calculation results and validity of the guidance provided are to be verified by the surveyor during sea trials.

Note 1: harmonic filters installed for single application frequency drives, such as pump motors, may be excluded from requirements of [3.5].

3.6 Main distribution of electrical power

3.6.1 Where the main source of electrical power is necessary for propulsion of the ship, the main busbar is to be divided into at least two parts which are normally to be connected by circuit breakers or other approved means such as circuit breakers without tripping mechanisms or disconnecting links or switches by means of which busbars can be split safely and easily.

The connection of generating sets and associated auxiliaries and other duplicated equipment is to be equally divided between the parts as far as practicable, so that in the event of damage to one section of the switchboard the remaining parts are still supplied.

3.6.2 (1/1/2021)

Two or more units serving the same consumer (e.g. main and standby lubricating oil pumps) are to be supplied by individual separate circuits without the use of common feeders, protective devices or control circuits.

This requirement is satisfied when such units are supplied by separate cables from the main switchboard or from two independent distribution boards.

3.6.3 *A main electric lighting system which shall provide illumination throughout those parts of the ship normally accessible to and used by (passengers or) crew shall be supplied from the main source of electrical power.*

3.7 Emergency distribution of electrical power

3.7.1 *The emergency switchboard shall be supplied during normal operation from the main switchboard by an interconnector feeder which shall be adequately protected at the main switchboard against overload and short-circuit and which is to be disconnected automatically at the emergency switchboard upon failure of the main source of electrical power.*

Where the system is arranged for feedback operation, the interconnector feeder is also to be protected at the emergency switchboard at least against short-circuit.

3.7.2 *In order to ensure ready availability of the emergency source of electrical power, arrangements shall be made where necessary to disconnect automatically non-emergency circuits from the emergency switchboard to ensure that power shall be available to the emergency circuits.*

3.7.3 (1/1/2023)

The emergency source of electrical power shall be capable of supplying simultaneously at least the following services for the periods specified hereafter, if they depend upon an electrical source for their operation:

- a) *for a period of 3 hours, emergency lighting at every muster and embarkation station and over the sides;*
- b) *for a period of 18 hours, emergency lighting:*
 - 1) *in all service and accommodation alleyways, stairways and exits, personnel lift cars and personnel lift trunks;*
 - 2) *in the machinery spaces and main generating stations including their control positions;*
 - 3) *in all control stations, machinery control rooms, and at each main and emergency switchboard;*
 - 4) *at all stowage positions for firemen's outfits;*
 - 5) *at the steering gear;*
 - 6) *at the fire pump referred to in (e) below, at the sprinkler pump, if any, at the emergency bilge pump, if any, and at the starting positions of their motors; and*
 - 7) *in all cargo pump-rooms of tanker*
- c) *for a period of 18 hours:*
 - 1) *the navigation lights and other lights required by the International Regulations for Preventing Collisions at Sea in force;*
 - 2) *on ships constructed on or after 1 February 1995 the VHF radio installation required by Regulation IV/7.1.1 and IV/7.1.2 of SOLAS Consolidated Edition 1992, and, if applicable:*
 - *the MF radio installation required by Regulations IV/9.1.1, IV/9.1.2, IV/10.1.2 and IV/10.1.3;*
 - *the ship earth station required by Regulation IV/10.1.1; and*
 - *the MF/HF radio installation required by Regulations IV/10.2.1, IV/10.2.2 and IV/11.1;*
- d) *for a period of 18 hours:*
 - 1) *all internal communication equipment as required in an emergency [3.7.4];*
 - 2) *the shipborne navigational equipment as required by Regulation V/19; where such provision is unreasonable or impracticable the Society may waive this requirement for ships of less than 5 000 tons gross tonnage;*
 - 3) *the fire detection and fire alarm systems (see Sec 1, [1.1.2]); and*
 - 4) *intermittent operation of the daylight signalling lamp, the ship's whistle, the manually operated call*

points and all internal signals (see [3.7.5]) that are required in an emergency;

unless such services have an independent supply for the period of 18 hours from an accumulator battery suitably located for use in an emergency;

- e) for a period of 18 hours: one of the fire pumps, when required, if dependent upon the emergency generator for its source of power (see Sec 1, [1.1.2]);
- f) for the period of time required in Ch 1, Sec 11, [2], the steering gear where it is required to be so supplied.

Note 1: for ships having navigation notation "sheltered area" or "special navigation" in an area at not more than 6 miles from the shore (see Sec 1, [1.1.3]) and not subject to the SOLAS convention, the Society may accept that the emergency source of electrical power is capable of supplying, for a period of not less than 2 times the expected duration of the longest voyage, but not less than:

- 3 hours, or
- 30 minutes for ships having navigation notation "sheltered area",

only the following services:

- emergency lighting;
- navigation lights;
- radio installation;
- internal communication equipment and general alarm system;
- fire detection and alarm system;
- the steering gear pump (where it is required to be so supplied);
- fire pump (when required, if dependent upon the emergency source of electrical power for its source of power);
- power to the control, indication and alarm circuits of watertight and fire doors (where provided).

3.7.4 (1/7/2007)

Internal communication equipment required in an emergency generally includes:

- a) the means of communication between the navigating bridge and the steering gear compartment
- b) the means of communication between the navigating bridge and the position in the machinery space or control room from which the engines are normally controlled
- c) the public address system (see Sec 1, [1.1.2]).

3.7.5 (1/7/2007)

Internal signals required in an emergency generally include:

- a) general alarm (see Sec 1, [1.1.2])
- b) watertight door indication.

3.7.6 In a ship engaged regularly in voyages of short duration, i.e. voyages where the route is no greater than 20 nautical miles offshore or where the vessel has a class notation "Coastal Navigation", the Society may, if satisfied that an adequate standard of safety would be attained, accept a lesser period than the 18-hour period specified in [3.7.3] (item b to item e) but not less than 12 hours.

Note 1: In ships for which SOLAS is not applicable, a reduced period of time may be accepted.

Note 2: For passenger ships see Pt E, Ch 11, Sec 5.

3.7.7 The transitional source of emergency electrical power, where required, shall supply for half an hour at least

the following services if they depend upon an electrical source for their operation:

- a) the lighting required by [3.7.3](item a, b, c1); for this transitional phase, the required emergency electric lighting, in respect of the machinery space and the accommodation and service spaces may be provided by permanently fixed, individual, automatically charged, relay operated accumulator lamps; and
- b) all services required by [3.7.3] (item d1, d3, d4) unless such services have an independent supply for the period specified from an accumulator battery suitably located for use in an emergency.

3.8 Shore supply

3.8.1 Where arrangements are made for supplying the electrical installation from a source on shore or elsewhere, a suitable connection box is to be installed on the ship in a convenient location to receive the flexible cable from the external source.

3.8.2 (1/7/2006)

Permanently fixed cables of adequate rating are to be provided for connecting the box to the main switchboard or emergency switchboard.

3.8.3 Where necessary for systems with earthed neutrals, the box is to be provided with an earthed terminal for connection between the shore's and ship's neutrals or for connection of a protective conductor.

3.8.4 (1/7/2009)

The connection box is to contain a circuit-breaker or a switch-disconnector and fuses.

The shore connection is to be protected against short-circuit and overload; however, the overload protection may be omitted in the connection box if provided on the main or emergency switchboard.

3.8.5 Means are to be provided for checking the phase sequence of the incoming supply in relation to the ship's system.

3.8.6 (1/7/2009)

The cable connection to the box is to be provided with at least one switch-disconnector on the main or emergency switchboard.

3.8.7 (1/7/2009)

The shore connection is to be provided with an indicator at the main or emergency switchboard in order to show when the cable is energised.

3.8.8 At the connection box a notice is to be provided giving full information on the nominal voltage and frequency of the installation.

3.8.9 (1/7/2009)

The switch-disconnector on the main or emergency switchboard is to be interlocked with the generator circuit-breakers in order to prevent its closure when any generator is supplying the main or emergency switchboard unless special provisions to the satisfaction of the Society are taken to permit safe transfer of electrical load.

3.8.10 Adequate means are to be provided to equalise the potential between the hull and the shore when the electrical installation of the ship is supplied from shore.

3.8.11 (1/7/2013)

Where high voltage shore connections are provided, the requirements of Pt F, Ch 13, Sec 15 are to be complied with.

3.9 Supply of motors

3.9.1 A separate final sub-circuit is to be provided for every motor required for an essential service (and for every motor rated at 1 kW or more).

3.9.2 Each motor is to be provided with controlgear ensuring its satisfactory starting.

Depending on the capacity of the generating plant or the cable network, it may be necessary to limit the starting current to an acceptable value.

Direct on line starters are accepted if the voltage drop does not exceed 15% of the network voltage.

3.9.3 Efficient means are to be provided for the isolation of the motor and its associated control gear from all live poles of the supply.

Where the control gear is mounted on or adjacent to a switchboard, a disconnecting switch in the switchboard may be used for this purpose.

Otherwise, a disconnecting switch within the control gear enclosure or a separate enclosed disconnecting switch is to be provided.

3.9.4 Where the starter or any other apparatus for disconnecting the motor is remote from the motor itself, one of the following is to be arranged:

- a) provision for locking the circuit disconnecting switch in the OFF position
- b) an additional disconnecting switch fitted near the motor
- c) provision such that the fuses in each live pole or phase can be readily removed and retained by persons authorised to have access to the motor.

3.10 Specific requirements for special power services

3.10.1 For the supply and characteristics of the distribution of the following services see the requirements listed:

- Steering gear: Ch 1, Sec 11, [2]
- Fire-extinguishing and detecting systems: Ch 4, Sec 1, [6]
- Permanently installed submergible bilge pump: Ch 1, Sec 10, [6.7.7]
- Ventilation fans: Chapter 4
- Fuel pumps: Ch 1, Sec 10
- Pumps discharging overboard above the lightest water line and in way of the area of lifeboat and liferaft launching: Ch 1, Sec 10, [5.2.4].

3.10.2 All power circuits terminating in a bunker or cargo space are to be provided with a multiple-pole switch outside the space for disconnecting such circuits.

3.11 Power supply to heaters

3.11.1 Each heater rated more than 16A is to be connected to a separate final circuit.

3.12 Power supply to lighting installations

3.12.1 Final sub-circuits for lighting supplying more than one lighting point and for socket-outlets are to be fitted with protective devices having a current rating not exceeding 16 A.

3.13 Special lighting services

3.13.1 In spaces such as:

- main and large machinery spaces
- large galleys
- passageways
- stairways leading to boat-decks
- public spaces

there is to be more than one final sub-circuit for lighting such that failure of any one circuit does not reduce the lighting to an insufficient level.

3.13.2 Where the emergency installation is required, one of the circuits in [3.13.1] may be supplied from the emergency source of power.

3.13.3 All lighting circuits terminating in a bunker or cargo space are to be provided with a multiple-pole switch outside the space for disconnecting such circuits.

3.14 Navigation lights

3.14.1 (1/7/2003)

Navigation lights are to be connected separately to a distribution board specially reserved for this purpose.

Signalling lights may be connected to the navigation light distribution board, or to a separate distribution board.

3.14.2 (1/7/2003)

The navigation light distribution board is to be supplied from two alternative circuits, one from the main source of power and one from the emergency source of power; see also [3.7].

The transfer of supply is to be practicable from the bridge, for example by means of a switch.

3.14.3 Each navigation light is to be controlled and protected in each insulated pole by a double-pole switch and a fuse or, alternatively, by a double-pole circuit-breaker, fitted on the distribution board referred to in [3.14.1].

3.14.4 Where there are double navigation lights, i.e. lights with two lamps or where for every navigation light a spare is also fitted, the connections to such lights may run in a single cable provided that means are foreseen in the

distribution board to ensure that only one lamp or light may be supplied at any one time.

3.14.5 Each navigation light is to be provided with an automatic indicator giving audible and/or visual warning in the event of failure of the light. If an audible device alone is fitted, it is to be connected to a separate source of supply from that of the navigation lights, for example an accumulator (storage) battery.

If a visual signal is used connected in series with the navigation light, means are to be provided to prevent the extinction of the navigation light due to the failure of the visual signal.

A minimum level of visibility is to be assured in the case of use of dimmer devices.

3.15 General emergency alarm system

3.15.1 (1/7/2007)

For the application of this item [3.15], see Sec 1, [1.1.2].

3.15.2 (1/7/2002)

An electrically operated bell or klaxon or other equivalent warning system installed in addition to the ship's whistle or siren, for sounding the general emergency alarm signal, is to comply with the requirements of this sub-article.

For passenger ships not engaged in international voyages and cargo ships of less than 500 gross tonnage or of 500 gross tonnage and upwards not engaged in international voyages, the system is to be capable of operation from the navigating bridge, it is to be continuously supplied from an emergency source of electrical power and it is to comply with [3.15.3], [3.15.4], [3.15.9], [3.15.11] and [3.15.13].

3.15.3 The general emergency alarm system is to be supplemented by either a public address system complying with the requirements in [3.16] or other suitable means of communication.

3.15.4 Entertainment sound system is to be automatically turned off when the general alarm system is activated.

3.15.5 The system is to be continuously powered and is to have an automatic change-over to a standby power supply in case of loss of normal power supply.

An alarm is to be given in the event of failure of the normal power supply.

3.15.6 The system is to be powered by means of two circuits, one from the ship's main supply and the other from the emergency source of electrical power required by [2.3] and [3.7].

3.15.7 The system is to be capable of operation from the navigation bridge and, except for the ship's whistle, also from other strategic points.

Note 1: Other strategic points are taken to mean those locations, other than the navigation bridge, from where emergency situations are intended to be controlled and the general alarm system can be activated. A fire control station or a cargo control station should normally be regarded as strategic points.

3.15.8 The alarm is to continue to function after it has been triggered until it is manually turned off or is temporarily interrupted by a message on the public address system.

3.15.9 The alarm system is to be audible throughout all the accommodation and normal crew working spaces.

3.15.10 The minimum sound pressure level for the emergency alarm tone in interior and exterior spaces is to be 80 dB (A) and at least 10 dB (A) above ambient noise levels occurring during normal equipment operation with the ship underway in moderate weather.

3.15.11 In cabins without a loudspeaker installation, an electronic alarm transducer, e.g. a buzzer or similar, is to be installed.

3.15.12 The sound pressure level at the sleeping position in cabins and in cabin bathrooms is to be at least 75 dB (A) and at least 10 dB (A) above ambient noise levels.

3.15.13 For cables used for the general emergency alarm system, see [9.6].

3.16 Public address system

3.16.1 (1/7/2007)

For the application of this item [3.16], see Sec 1, [1.1.2].

3.16.2 (1/7/2002)

The public address system is to be a loudspeaker installation enabling the broadcast of messages into all spaces where people on board are normally present.

3.16.3 (1/7/2002)

In spaces such as under deck passageways, bosun's locker, hospital and pump rooms, the public address system is/may not be required.

For passenger ships not engaged in international voyages and cargo ships of less than 500 gross tonnage or of 500 gross tonnage and upwards not engaged in international voyages, item [3.16.9] does not apply.

3.16.4 Where the public address system is used to supplement the general emergency alarm system as per [3.15.3], it is to be continuously powered from the emergency source of electrical power required by [3.7].

3.16.5 The system is to allow for the broadcast of messages from the navigation bridge and from other places on board the ship as deemed necessary.

3.16.6 The system is to be protected against unauthorised use.

3.16.7 The system is to be installed with regard to acoustically marginal conditions and not require any action from the addressee.

3.16.8 Where an individual loudspeaker has a device for local silencing, an override arrangement from the control station(s), including the navigating bridge, is to be in place.

3.16.9 With the ship underway in normal conditions, the minimum sound pressure level for broadcasting emergency announcements is to be:

- a) in interior spaces, 75 dB (A) and at least 20 dB (A) above the speech interference level
- b) in exterior spaces, 80 dB (A) and at least 15 dB (A) above the speech interference level.

With respect to cabin/state rooms, the sound pressure level is to be attained as required inside such spaces during sea trials.

3.16.10 (1/7/2013)

For cables used for the public address system, see [9.6].

3.17 Combined general emergency alarm - public address system

3.17.1 (1/7/2007)

For the application of this item [3.17], see Sec 1, [1.1.2].

3.17.2 Where the public address system is the only means for sounding the general emergency alarm signal and the fire alarm, in addition to the requirements of [3.15] and [3.16], the following are to be satisfied:

- the system automatically overrides any other input system when an emergency alarm is required
- the system automatically overrides any volume control provided to give the required output for the emergency mode when an emergency alarm is required
- the system is arranged to prevent feedback or other interference
- the system is arranged to minimise the effect of a single failure so that the alarm signal is still audible (above ambient noise levels) also in the case of failure of any one circuit or component, by means of the use of:
 - multiple amplifiers
 - segregated cable routes to public rooms, alleyways, stairways and control stations
 - more than one device for generating electronic sound signal
 - electrical protection for individual loudspeakers against short-circuits.

3.18 Control and indication circuits

3.18.1 For the supply of automation systems, comprising control, alarm and safety system, see the requirements of Chapter 3.

3.18.2 Control and indicating circuits relative to primary essential services are to be branched off from the main circuit in which the relevant equipment is installed. Equivalent arrangements may be accepted by the Society.

3.18.3 Control and indicating circuits relative to secondary essential services and to non-essential services may be supplied by distribution systems reserved for the purpose to the satisfaction of the Society.

3.19 Power supply to the speed control systems of main propulsion engines

3.19.1 Electrically operated speed control systems of main engines are to be fed from the main source of electrical power.

3.19.2 (1/1/2021)

Where more than one main propulsion engine is foreseen, each speed control system is to be provided with an individual supply by means of separate wiring from the main switchboard or from two independent distribution boards.

Where the main busbars are divided into two sections, the governors are, as far as practicable, to be supplied equally from the two sections.

3.19.3 In the case of propulsion engines which do not depend for their operation on electrical power, i.e. pumps driven from the main engine, the speed control systems are to be fed both from the main source of electrical power and from an accumulator battery for at least 15 minutes or from a similar supply source.

Such battery may also be used for other services such as automation systems, where foreseen.

3.20 Power supply to the speed control systems of generator sets

3.20.1 Each electrically operated control and/or speed control system of generator sets is to be provided with a separate supply from the main source of electric power and from an accumulator battery for at least 15 minutes or from a similar supply source.

3.20.2 The wiring supplying the main source of electrical power is to be from the main switchboard or from independent section boards.

Where the main busbars are divided into two sections, the governors are, as far as practicable, to be supplied from the sections to which the relevant generators are connected.

4 Degrees of protection of the enclosures

4.1 General

4.1.1 The minimum required degree of protection for electrical equipment, in relation to the place of installation, is generally that specified in Tab 2.

4.1.2 Equipment supplied at nominal voltages in excess of 500 V and accessible to non-authorised personnel (e.g. equipment not located in machinery spaces or in locked compartments under the responsibility of the ship's officers) is to have a degree of protection against touching live parts of at least IP4X.

4.1.3 In addition to the requirements of this sub-article, equipment installed in spaces with an explosion hazard is also subject to the provisions of Sec 2, [6].

4.1.4 The enclosures of electrical equipment for the monitoring and control of watertight doors which are situated below the bulkhead deck are to provide suitable protection against the ingress of water.

In particular, the minimum required degree of protection is to be:

- IPX7 for electric motors, associated circuits and control components
- IPX8 for door position indicators and associated circuit components
- IPX6 for door movement warning signals.

Note 1: The water pressure testing of the enclosures protected to IPX8 is to be based on the pressure that may occur at the location of the component during flooding for a period of 36 hours.

Table 2 : Minimum required degrees of protection

Condition in location	Example of location	Switchboard Control gear Motor start- ers	Gener- ators	Motors	Trans- formers	Lumi- naires	Heating appli- ances	Cook- ing appli- ances	Socket outlets	Accessories (e.g. switches, connection boxes)
Danger of touch- ing live parts only	Dry accommoda- tion spaces Dry control rooms	IP 20	X (1)	IP 20	IP 20	IP 20	IP20	IP 20	IP 20	IP 20
Danger of drip- ping liquid and/or moderate mechanical damage	Control rooms, wheel-house, radio room	IP 22	X	IP 22	IP 22	IP 22	IP22	IP 22	IP 22	IP 22
	Engine and boiler rooms above floor	IP 22	IP 22	IP 22	IP 22	IP 22	IP22	IP 22	IP 44	IP 44
	Steering gear rooms	IP 22	IP 22	IP 22	IP 22	IP 22	IP22	X	IP 44	IP 44
	Emergency machinery rooms	IP 22	IP 22	IP 22	IP 22	IP 22	IP22	X	IP 44	IP 44
	General store- rooms	IP 22	X	IP 22	IP 22	IP 22	IP22	X	IP 22	IP 44
	Pantries	IP 22	X	IP 22	IP 22	IP 22	IP22	IP 22	IP 44	IP 44
	Provision rooms	IP 22	X	IP 22	IP 22	IP 22	IP22	X	IP 44	IP 44
	Ventilation ducts	X	X	IP 22	X	X	X	X	X	X
Increased dan- ger of liquid and/or mechani- cal damage	Bathrooms and/or showers	X	X	X	X	IP 34	IP44	X	IP 55	IP 55
	Engine and boiler rooms below floor	X	X	IP 44	X	IP 34	IP44	X	X	IP 55
	Closed fuel oil separator rooms	IP 44	X	IP 44	IP 44	IP 34	IP44	X	X	IP 55
	Closed lubricat- ing oil separator rooms	IP 44	X	IP 44	IP 44	IP 34	IP44	X	X	IP 55
Increased dan- ger of liquid and mechanical damage	Ballast pump rooms	IP 44	X	IP 44 (2)	IP 44 (2)	IP 34	IP44	X	IP 55	IP 55
	Refrigerated rooms	X	X	IP 44	X	IP 34	IP44	X	IP 55	IP 55
	Galleys and laundries	IP 44	X	IP 44	IP 44	IP 34	IP44	IP 44	IP 44	IP 44
	Public bathrooms and shower	X	X	IP 44	IP 44	IP 34	IP44	X	IP 44	IP 44

Condition in location	Example of location	Switchboard Control gear Motor starters	Generators	Motors	Transformers	Luminaires	Heating appliances	Cooking appliances	Socket outlets	Accessories (e.g. switches, connection boxes)
Danger of liquid spraying. Presence of cargo dust. Serious mechanical damage. Aggressive fumes	Shaft or pipe tunnels in double bottom	IP 55	X	IP 55	IP 55	IP 55	IP55	X	IP 56	IP 56
	Holds for general cargo	X	X	IP 55	X	IP 55	IP55	X	IP 56	IP 56
	Ventilation trunks	X	X	IP 55	X	X	X	X	X	X
Danger of liquid in massive quantities	Open decks	IP 56	X	IP 56	X	IP 55	IP56	X	IP 56	IP 56
(1) The symbol "X" denotes equipment which it is not advised to install.										
(2) Electric motors and starting transformers for lateral thrust propellers located in spaces similar to ballast pump rooms may have degree of protection IP22.										

Table 3 : Required Environmental Categories (1/7/2017)

Location within main area				
Main Areas on Board	General	Inside cubicles, desks, etc.	On machinery such as internal combustion engines, compressors	Masts
Machinery Spaces/Steering Gear	EC21	EC3a1	EC3b3	X (1)
Control Room, Accommodation	EC21 EC11C	EC3a1	X	X
Bridge	EC21 EC11C	EC3a1	X	X
Pump Room, Holds, Rooms with no Heating	EC41	X	X	X
Exposed Decks	EC41S	X	X	EC42S
(1) The symbol "X" denotes locations which are generally not applicable.				

4.1.5 (1/7/2005)

For electrical and electronic equipment installed in engine rooms protected by fixed water-based local application fire-fighting systems, see Ch 4, Sec 1, [7] .

5 Diversity (demand) factors

5.1 General

5.1.1 The cables and protective devices of final sub-circuits are to be rated in accordance with their connected load.

5.1.2 Circuits supplying two or more final sub-circuits are to be rated in accordance with the total connected load subject, where justifiable, to the application of a diversity (demand) factor.

5.1.3 A diversity (demand) factor may be applied provided that the known or anticipated operating conditions in a particular part of an installation are suitable for the application of diversity.

6 Environmental categories of the equipment

6.1 Environmental categories

6.1.1 The environmental categories of the electrical equipment, in relation to the place of installation, are generally to be those specified in Tab 3.

6.1.2 For ships operating outside the tropical belt, the maximum ambient air temperature may be assumed as equal to + 40 °C instead of + 45 °C, so that the first characteristic numeral changes from 1 to 3.

7 Electrical protection

7.1 General requirements for overcurrent protection

7.1.1 Electrical installations are to be protected against accidental overcurrents including short-circuit.

The choice, arrangement and performance of the various protective devices are to provide complete and coordinated automatic protection in order to ensure as far as possible:

- continuity of service in the event of a fault, through coordinated and discriminative action of the protective devices
- elimination of the effects of faults to reduce damage to the system and the hazard of fire as far as possible.

Note 1: An overcurrent is a current exceeding the nominal current.

Note 2: A short-circuit is the accidental connection by a relatively low resistance or impedance of two or more points in a circuit which are normally at different voltages.

7.1.2 Devices provided for overcurrent protection are to be chosen according to the requirements, especially with regard to overload and short-circuit.

Note 1: Overload is an operating condition in an electrically undamaged circuit which causes an overcurrent.

7.1.3 Systems are to be such as to withstand the thermal and electrodynamic stresses caused by the possible overcurrent, including short-circuit, for the admissible duration.

7.2 Short-circuit currents

7.2.1 In calculating the maximum prospective short-circuit current, the source of current is to include the maximum number of generators which can be simultaneously connected (as far as permitted by any interlocking arrangements), and the maximum number of motors which are normally simultaneously connected in the system.

The maximum number of generators or transformers is to be evaluated without taking into consideration short-term parallel operation (e.g. for load transfer) provided that suitable interlock is foreseen.

7.2.2 Short-circuit current calculations are to be performed in accordance with a method recognised by the Society, such as that given in IEC Publication 61363-1.

7.2.3 In the absence of precise data concerning the characteristics of generators, accumulator batteries and motors, the maximum short-circuit currents on the main busbars may be calculated as follows:

- for alternating current systems:

$$I_{ac} = 10 I_{TG} + 3,5 I_{TM}$$

$$I_{pk} = 2,4 I_{ac}$$

- for direct current systems supplied by batteries:

$$I_p = K C_{10} + 6 I_{TM}$$

where:

- I_p : Maximum short-circuit current
- I_{ac} : r.m.s. value of the symmetrical component (at the instant T/2)
- I_{pk} : Maximum peak value
- I_{TG} : Rated current of all generators which can be connected simultaneously
- C_{10} : Battery capacity in Ah for a discharge duration of 10 hours
- K : Ratio of the short-circuit current of the batteries to C_{10} ; (see Note 1)

I_{TM} : Rated current of all motors which are normally simultaneously connected in the system.

Note 1: For stationary batteries the following values may be assumed for guidance:

- vented lead-acid batteries: $K = 8$
- vented alkaline type batteries intended for discharge at low rates corresponding to a battery duration exceeding three hours: $K = 15$
- sealed lead-acid batteries having a capacity of 100 Ah or more or alkaline type batteries intended for discharge at high rates corresponding to a battery duration not exceeding three hours: $K = 30$.

7.3 Selection of equipment

7.3.1 (1/7/2013)

Circuit-breakers are to be suitable for isolation.

Circuit-breakers of withdrawable type are required where they are not suitable for isolation.

7.3.2 Equipment is to be chosen on the basis of its rated current and its making/breaking capacity.

7.3.3 (1/7/2013)

In the selection of circuit-breakers with intentional short-time delay for short-circuit release (e.g. generator circuit-breakers), those of utilisation category B are to be used and they are to be selected also taking into account their rated short-time withstand current capacity (I_{cw}).

For circuit-breakers without intentional short-time delay for short-circuit release, circuit breakers of utilisation category A may be used and they are to be selected according to their rated service short-circuit breaking capacity (I_{cs}).

Note 1: For the purpose of these Rules, circuit breakers are distinguished according to the utilization categories A and B in compliance with IEC publication 60947-2 as follows:

- Utilisation category A: circuit-breakers not specifically intended for selectivity under short-circuit conditions with respect to other short-circuit protective devices in series on the load side, i.e. without an intentional short-time delay provided for selectivity under short-circuit conditions and therefore without a short-time withstand current rating (I_{cw}).
- Utilisation category B: circuit-breakers specifically intended for selectivity under short-circuit conditions with respect to other short-circuit protective devices in series on the load side, i.e. with an intentional short-time delay (which may be adjustable) provided for selectivity under short-circuit conditions. Such circuit-breakers have a short-time withstand current rating (I_{cw}).

7.3.4 For duplicated essential services and non-essential services, circuit-breakers may be selected according to their ultimate short-circuit breaking capacity (I_{cu}).

7.3.5 (1/7/2013)

Circuit breakers used in insulated systems are to comply with Annex H of IEC Publication 60947-2.

7.3.6 For switches, the making/breaking capacity is to be in accordance with utilisation category AC-22 A or DC-22 A (in compliance with IEC Publication 60947-3).

7.3.7 For fuse-switch disconnectors or switch-disconnector fuse units, the making/breaking capacity is to be in accordance with utilisation categories AC-23 A or DC-23 A (in compliance with IEC Publication 60947-3).

7.4 Protection against short-circuit

7.4.1 Protection against short-circuit currents is to be provided by circuit-breakers or fuses.

7.4.2 The rated short-circuit breaking capacity of every protective device is to be not less than the maximum prospective value of the short-circuit current at the point of installation at the instant of contact separation.

7.4.3 The rated short-circuit making capacity of every mechanical switching device intended to be capable of being closed on short-circuit is to be not less than the maximum value of the short-circuit current at the point of installation. On alternating current this maximum value corresponds to the peak value allowing for maximum asymmetry.

7.4.4 Every protective device or contactor not intended for short-circuit interruption is to be adequate for the maximum short-circuit current liable to occur at the point of installation having regard to the time required for the short-circuit to be removed.

7.4.5 The use of a protective device not having a short-circuit breaking or making capacity at least equal to the maximum prospective short-circuit current at the point where it is installed is permitted, provided that it is backed up on the generator side by a fuse or by a circuit-breaker having at least the necessary short-circuit rating and not being the generator circuit-breaker.

7.4.6 The same fuse or circuit-breaker may back up more than one circuit-breaker where the circuits concerned do not involve essential services.

7.4.7 The short-circuit performance of the back-up arrangement is to be equal to the requirements of IEC Publication 60947-2 for a single circuit-breaker having the same short-circuit performance category as the backed-up circuit-breaker and rated for the maximum prospective short-circuit level at the supply terminals of the arrangement.

7.4.8 Circuit-breakers with fuses connected to the load side may be used, provided the back-up fuses and the circuit-breakers are of coordinated design, in order to ensure that the operation of the fuses takes place in due time so as to prevent arcing between poles or against metal parts of the circuit-breakers when they are submitted to overcurrents involving the operation of the fuse.

7.4.9 When determining the performance requirements for the above-mentioned back-up protection arrangement, it is permissible to take into account the impedance of the various circuit elements of the arrangement, such as the impedance of a cable connection when the backed-up circuit-breaker is located away from the back-up breaker or fuse.

7.5 Continuity of supply and continuity of service

7.5.1 The protection of circuits is to be such that a fault in one service does not cause the loss of any essential services.

7.5.2 The protection of the emergency circuit is to be such that a failure in one circuit does not cause a loss of other emergency services.

Note 1: The continuity of supply for the primary essential services and the continuity of service for the secondary essential services are to be ensured.

The continuity of supply is the condition for which during and after a fault in a circuit, the supply to the healthy circuits (see circuit 3 in Fig 2) is permanently ensured.

The continuity of service is the condition for which after a fault in a circuit has been cleared, the supply to the healthy circuits (see circuit 3 in Fig 2) is re-established.

7.6 Protection against overload

7.6.1 Devices provided for overload protection are to have a tripping characteristic (overcurrent-trip time) adequate for the overload ability of the elements of the system to be protected and for any discrimination requirements.

7.6.2 The use of fuses up to 320 A for overload protection is permitted.

7.7 Localisation of overcurrent protection

7.7.1 Short-circuit protection is to be provided for every non-earthed conductor.

7.7.2 Overload protection is to be provided for every non-earthed conductor; nevertheless, in insulated single-phase circuits or insulated three-phase circuits having substantially balanced loads, the overload protection may be omitted on one conductor.

7.7.3 Short-circuit and overload protective devices are not to interrupt earthed conductors, except in the case of multiple disconnection devices which simultaneously interrupt all the conductors, whether earthed or not.

7.7.4 Electrical protection is to be located as close as possible to the origin of the protected circuit.

7.8 Protection of generators

7.8.1 Generators are to be protected against short-circuits and overloads by multipole circuit-breakers.

For generators not arranged to operate in parallel with a rated output equal to or less than 50 kVA, a multipole switch with a fuse in each insulated phase on the generator side may be accepted.

7.8.2 When multipole switch and fuses are used, the fuse rating is to be maximum 110% of the generator rated current.

Figure 2

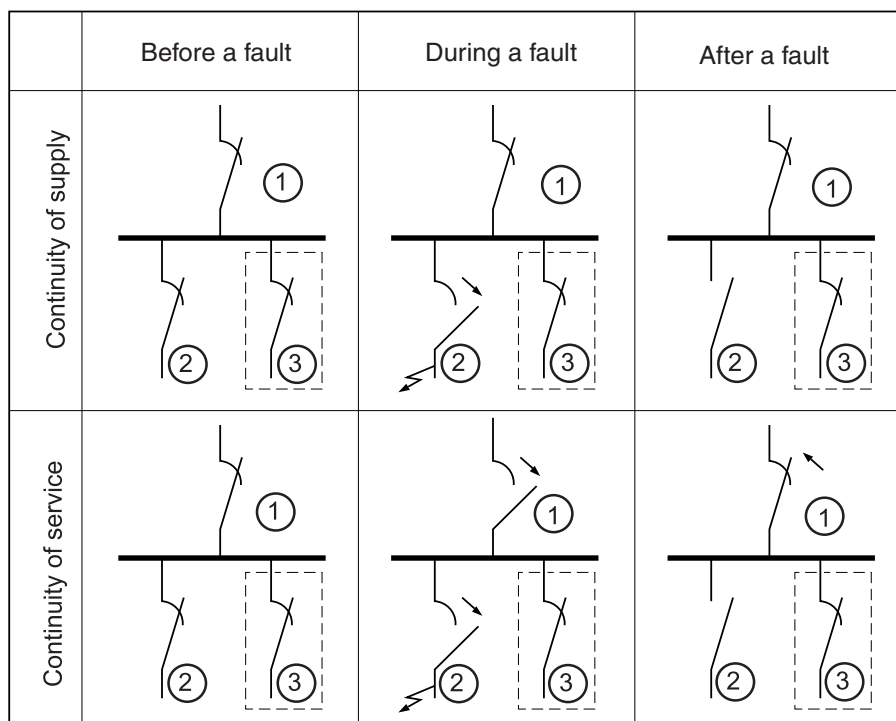

7.8.3 Where a circuit-breaker is used:

- a) the overload protection is to trip the generator circuit-breaker at an overload between 10% and 50%; for an overload of 50% of the rated current of the generator the time delay is not to exceed 2 minutes; however, the figure of 50% or the time delay of 2 minutes may be exceeded if the construction of the generator permits this
- b) the setting of the short-circuit protection is to instantaneously trip the generator circuit-breaker at an overcurrent less than the steady short-circuit current of the generator. Short time delays (e.g. from 0,5 s to 1 s) may be introduced for discrimination requirements in "instantaneous" tripping devices.

7.8.4 For emergency generators the overload protection may, instead of disconnecting the generator automatically, give a visual and audible alarm in a permanently attended space.

7.8.5 After disconnection of a generator due to overload, the circuit-breaker is to be ready for immediate reclosure.

7.8.6 Generator circuit-breakers are to be provided with a reclosing inhibitor which prevents their automatic reclosure after tripping due to a short-circuit.

7.8.7 Generators having a capacity of 1500 kVA or above are to be equipped with a suitable protective device or system which, in the event of a short-circuit in the generator or in the supply cable between the generator and its circuit-breaker, will de-excite the generator and open the circuit-breaker (e.g. by means of differential protection).

7.8.8 Where the main source of electrical power is necessary for the propulsion of the ship, load shedding or other equivalent arrangements are to be provided to protect the generators against sustained overload.

7.8.9 Arrangements are to be made to disconnect or reduce automatically the excess load when the generators are overloaded in such a way as to prevent a sustained loss of speed and/or voltage (see Sec 2, Tab 6). The operation of such device is to activate a visual and audible alarm. A time delay of 5-20 s is considered acceptable.

7.8.10 When an overload is detected the load shedding system is to disconnect automatically, after an appropriate time delay, the circuits supplying the non-essential services and, if necessary, the secondary essential services in a second stage.

7.8.11 Alternating current generators arranged to operate in parallel are to be provided with reverse-power protection.

The protection is to be selected in accordance with the characteristics of the prime mover.

The following values are recommended:

- 2-6% of the rated power for turbogenerators
- 8-15% of the rated power for diesel generators.

The reverse-power protection may be replaced by other devices ensuring adequate protection of the prime movers.

7.8.12 Generators are to be provided with an undervoltage protection which trips the breaker if the voltage falls to 70% - 35% of the rated voltage.

For generators arranged for parallel operation, measures are to be taken to prevent the generator breaker from closing if the generator is not generating and to prevent the generator remaining connected to the busbars if voltage collapses.

The operation of the undervoltage release is to be instantaneous when preventing closure of the breaker, but it is to be delayed for selectivity purposes when tripping the breaker.

7.9 Protection of circuits

7.9.1 *Each separate circuit shall be protected against short-circuit and against overload, unless otherwise specified in these Rules or where the Society may exceptionally otherwise permit.*

7.9.2 Each circuit is to be protected by a multipole circuit-breaker or switch and fuses against overloads and short-circuits.

7.9.3 Circuits for lighting are to be disconnected on both non-earthed conductors; single-pole disconnection of final sub-circuits with both poles insulated is permitted only in accommodation spaces.

7.9.4 The protective devices of the circuits supplying motors are to allow excess current to pass during transient starting of motors.

7.9.5 Final sub-circuits which supply one consumer with its own overload protection (for example motors), or consumers which cannot be overloaded (for example permanently wired heating circuits and lighting circuits), may be provided with short-circuit protection only.

7.9.6 Steering gear circuits are to be provided with short-circuit protection only (see Ch 1, Sec 11, [2]).

7.10 Protection of motors

7.10.1 Motors of rating exceeding 1 kW and all motors for essential services are to be protected individually against overload and short-circuit. The short-circuit protection may be provided by the same protective device for the motor and its supply cable (see [7.9.5]).

7.10.2 For motors intended for essential services, the overload protection may be replaced by an overload alarm (for steering gear motors see Ch 1, Sec 11, [2]).

7.10.3 The protective devices are to be designed so as to allow excess current to pass during the normal accelerating period of motors according to the conditions corresponding to normal use.

If the current/time characteristic of the overload protection device does not correspond to the starting conditions of a motor (e.g. for motors with extra-long starting period), provision may be made to suppress operation of the device during the acceleration period on condition that the short-circuit protection remains operative and the suppression of overload protection is only temporary.

7.10.4 For continuous duty motors the protective gear is to have a time delay characteristic which ensures reliable thermal protection against overload.

7.10.5 The protective devices are to be adjusted so as to limit the maximum continuous current to a value within the range 105% - 120% of the motor's rated full load current.

7.10.6 For intermittent duty motors the current setting and the delay (as a function of time) of the protective devices are to be chosen in relation to the actual service conditions of the motor.

7.10.7 Where fuses are used to protect polyphase motor circuits, means are to be provided to protect the motor against unacceptable overload in the case of single phasing.

7.10.8 Motors rated above 1 kW are to be provided with:

- undervoltage protection, operative on the reduction or failure of voltage, to cause and maintain the interruption of power in the circuit until the motor is deliberately restarted or
- undervoltage release, operative on the reduction or failure of voltage, so arranged that the motor restarts automatically when power is restored after a power failure.

7.10.9 The automatic restart of a motor is not to produce a starting current such as to cause excessive voltage drop.

In the case of several motors required to restart automatically, the total starting current is not to cause an excessive voltage drop or sudden surge current; to this end, it may be necessary to achieve a sequence start.

7.10.10 The undervoltage protective devices are to allow the motor to be started when the voltage exceeds 85% of the rated voltage and are to intervene without fail when the voltage drops to less than approximately 20% of the rated voltage, at the rated frequency and with a time delay as necessary.

7.11 Protection of storage batteries

7.11.1 Batteries are to be protected against overload and short-circuit by means of fuses or multipole circuit-breakers at a position adjacent to the battery compartment.

Overcurrent protection may be omitted for the circuit to the starter motors when the current drawn is so large that is impracticable to obtain short-circuit protection.

7.11.2 Emergency batteries supplying essential services are to have short-circuit protection only.

7.12 Protection of shore power connection

7.12.1 Permanently fixed cables connecting the shore connection box to the main switchboard are to be protected by fuses or circuit-breakers (see [3.8.4]).

7.13 Protection of measuring instruments, pilot lamps and control circuits

7.13.1 Measuring circuits and devices (voltage transformers, voltmeters, voltage coils of measuring instruments, insulation monitoring devices etc.) and pilot lamps are to be protected against short-circuit by means of multipole circuit-breakers or fuses.

The protective devices are to be placed as near as possible to the tapping from the supply.

The secondary side of current transformers is not to be protected.

7.13.2 Control circuits and control transformers are to be protected against overload and short-circuit by means of multipole circuit-breakers or fuses on each pole not connected to earth.

Overload protection may be omitted for transformers with a rated current of less than 2 A on the secondary side.

The short-circuit protection on the secondary side may be omitted if the transformer is designed to sustain permanent short-circuit current.

7.13.3 Where a fault in a pilot lamp would impair the operation of essential services, such lamps are to be protected separately from other circuits such as control circuits.

Note 1: Pilot lamps connected via short-circuit-proof transformers may be protected in common with control circuits.

7.13.4 Circuits whose failure could endanger operation, such as steering gear control feeder circuits, are to be protected only against short-circuit.

7.13.5 The protection is to be adequate for the minimum cross-section of the protected circuits.

7.14 Protection of transformers

7.14.1 The primary winding side of power transformers is to be protected against short-circuit and overload by means of multipole circuit-breakers or switches and fuses.

Overload protection on the primary side may be dispensed with where it is provided on the secondary side or when the total possible load cannot reach the rated power of the transformer.

7.14.2 The protection against short-circuit is to be such as to ensure the selectivity between the circuits supplied by the secondary side of the transformer and the feeder circuit of the transformer.

7.14.3 When transformers are arranged to operate in parallel, means are to be provided so as to trip the switch on the secondary winding side when the corresponding switch on the primary side is open.

8 System components

8.1 General

8.1.1 The components of the electrical system are to be dimensioned such as to withstand the currents that can pass through them during normal service without their rating being exceeded.

8.1.2 The components of the electrical system are to be designed and constructed so as to withstand for the admissible duration the thermal and electrodynamic stresses caused by possible overcurrents, including short-circuit.

9 Electrical cables

9.1 General

9.1.1 *All electrical cables and wiring external to equipment shall be at least of a flame-retardant type, in accordance with IEC Publication 60332-1.*

9.1.2 In addition to the provisions of [9.1.1], when cables are laid in bundles, cable types are to be chosen in compliance with IEC Publication 60332-3 Category A, or other means (see Sec 12) are to be provided such as not to impair their original flame-retarding properties.

9.1.3 Where necessary for specific applications such as radio frequency or digital communication systems, which require the use of particular types of cables, the Society may permit the use of cables which do not comply with the provisions of [9.1.1] and [9.1.2].

9.1.4 (1/1/2007)

Cables which are required to have fire-resisting characteristics are to comply with the requirements stipulated in [9.6].

9.2 Choice of insulation

9.2.1 The maximum rated operating temperature of the insulating material is to be at least 10°C higher than the maximum ambient temperature liable to occur or to be produced in the space where the cable is installed.

9.2.2 The maximum rated conductor temperature for normal and short-circuit operation, for the type of insulating compounds normally used for shipboard cables, is not to exceed the values stated in Tab 4. Special consideration will be given to other insulating materials.

9.2.3 PVC insulated cables are not to be used either in refrigerated spaces, or on decks exposed to the weather of ships classed for unrestricted service.

9.2.4 Mineral insulated cables will be considered on a case by case basis.

9.3 Choice of protective covering

9.3.1 The conductor insulating materials are to be enclosed in an impervious sheath of material appropriate to

the expected ambient conditions where cables are installed in the following locations:

- on decks exposed to the weather,
- in damp or wet spaces (e.g. in bathrooms),
- in refrigerated spaces,
- in machinery spaces and, in general,
- where condensation water or harmful vapour may be present.

9.3.2 Where cables are provided with armour or metallic braid (e.g. for cables installed in hazardous areas), an overall impervious sheath or other means to protect the metallic elements against corrosion is to be provided: see Sec 9, [1.5].

9.3.3 An impervious sheath is not required for single-core cables installed in tubes or ducts inside accommodation spaces, in circuits with maximum system voltage 250 V.

9.3.4 In choosing different types of protective coverings, due consideration is to be given to the mechanical action to which each cable may be subjected during installation and in service.

If the mechanical strength of the protective covering is considered insufficient, the cables are to be mechanically protected (e.g. by an armour or by installation inside pipes or conduits).

9.3.5 Single-core cables for a.c. circuits with rated current exceeding 20 A are to be either non-armoured or armoured with non-magnetic material.

9.4 Cables in refrigerated spaces

9.4.1 Cables installed in refrigerated spaces are to have a watertight or impervious sheath and are to be protected against mechanical damage. If an armour is applied on the sheath, the armour is to be protected against corrosion by a further moisture-resisting covering.

9.5 Cables in areas with a risk of explosion

9.5.1 For cables in areas with a risk of explosion, see [10].

9.6 Electrical services required to be operable under fire conditions and fire-resistant cables

9.6.1 (1/1/2007)

Electrical services required to be operable under fire conditions are as follows:

- Control and power systems to power-operated fire doors and status indication for all fire doors
- Control and power systems to power-operated watertight doors and their status indication
- Emergency fire pump
- Emergency lighting
- Fire and general alarms
- Fire detection systems

- Fire-extinguishing systems and fire-extinguishing media release alarms
- Low location lighting
- Public address systems
- Remote emergency stop/shutdown arrangements for systems which may support the propagation of fire and/or explosion.

9.6.2 (1/1/2022)

Where cables for services specified in [9.6.1] including their power supplies pass through high fire risk areas (see Note 1), and in addition for passenger ships, main vertical fire zones, other than those which they serve, they are to be so arranged that a fire in any of these areas or zones does not affect the operation of the service in any other area or zone. This may be achieved by either of the following measures:

- Cables being of a fire-resistant type complying with IEC 60331-1 for cables of greater than 20 mm overall diameter, otherwise IEC 60331-21 or IEC 60331-2 for cables with an overall diameter not exceeding 20 mm, are installed and run continuous to keep the fire integrity within the high fire risk area (see Fig 3).
- At least two loops/radial distributions run as widely apart as is practicable and so arranged that in the event of damage by fire at least one of the loops/radial distributions remains operational.

Systems that are, fail safe or duplicated with cable runs as widely separated as is practicable may be exempted.

Note 1:

a) For the purpose of application of this item [9.6], the definition of "high fire risk areas" is the following:

(1) Machinery spaces as defined by Chapter 4 Regulation 3.30 of SOLAS Chapter II-2, as amended by IMO resolutions up to MSC.421(98) (hereinafter the same), except spaces having little or no fire risk as defined by paragraph (10) of Regulation 9.2.2.3.2.2 of SOLAS Chapter II-2 (including the interpretations for tables 9.3, 9.4, 9.5, 9.6, 9.7 and 9.8 given in MSC/Circ.1120 as amended by MSC.1/Circ.1436 and MSC.1/Circ.1510)

(2) Spaces containing fuel treatment equipment and other highly flammable substances

(3) Galley and Pantries containing cooking appliances

(4) Laundry containing drying equipment

(5) Spaces as defined by paragraphs (8), (12), and (14) of Reg. 9.2.2.3.2.2 of SOLAS Chapter II-2 for ships carrying more than 36 passengers

b) Fire-resistant type cables are to be easily distinguishable.

c) For special cables, requirements in the following standards may be used:

(1) IEC60331-23: Procedures and requirements - Electric data cables

(2) IEC60331-25: Procedures and requirements - Optical fibre cables.

9.6.3 (1/1/2016)

The electrical cables to the emergency fire pump are not to pass through the machinery spaces containing the main fire pumps and their source(s) of power and prime mover(s).

They are to be of a fire resistant type, in accordance with [9.6.2] a), where they pass through other high fire risk areas.

9.7 Cables for submerged bilge pumps

9.7.1 Cables and their connections to such pumps are to be capable of operating under a head of water equal to their distance below the bulkhead deck. The cable is to be impervious-sheathed and armoured, is to be installed in continuous lengths from above the bulkhead to the motor terminals and is to enter the air bell from the bottom.

9.8 Internal wiring of switchboards and other enclosures for equipment

9.8.1 For installation in switchboards and other enclosures for equipment, single-core cables may be used without further protection (sheath).

Other types of flame-retardant switchboard wiring may be accepted at the discretion of the Society.

9.9 Current carrying capacity of cables

9.9.1 The current carrying capacity for continuous service of cables given in Tab 5 to Tab 9 is based on the maximum

permissible service temperature of the conductor also indicated therein and on an ambient temperature of 45°C.

9.9.2 The current carrying capacity cited in [9.9.1] is applicable, with rough approximation, to all types of protective covering (e.g. both armoured and non-armoured cables).

9.9.3 Values other than those shown in Tab 5 to Tab 9 may be accepted provided they are determined on the basis of calculation methods or experimental values approved by the Society.

9.9.4 When the actual ambient temperature obviously differs from 45°C, the correction factors shown in Tab 10 may be applied to the current carrying capacity in Tab 5 to Tab 9.

9.9.5 Where more than six cables are bunched together in such a way that there is an absence of free air circulating around them, and the cables can be expected to be under full load simultaneously, a correction factor of 0,85 is to be applied.

Figure 3 (1/1/2007)

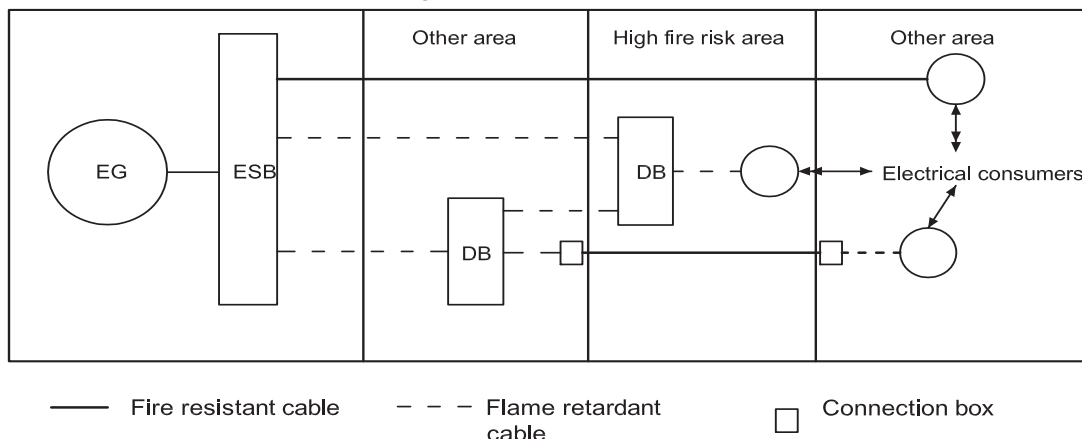

Table 4 : Maximum rated conductor temperature (1/7/2024)

Type of insulating compound	Abbreviated designation	Maximum rated conductor temperature, in °C	
		Normal operation	Short-circuit
a) Thermoplastic: - based upon polyvinyl chloride or copolymer of vinyl chloride and vinyl acetate	PVC	70	150
b) Elastomeric or thermosetting:			
- based upon ethylene-propylene rubber or similar (EPM or EPDM)	EPR	90	250
- based upon high modulus or hardgrade ethylene propylene rubber	HEPR	90	250
- based upon cross-linked polyethylene	XLPE	90	250
- based upon rubber silicon	S 95	95	350 (2)
- based upon ethylene-propylene rubber or similar (EPM or EPDM) halogen free	HF EPR	90	250
- based upon high modulus or hardgrade halogen free ethylene propylene rubber	HF HEPR	90	250
- based upon cross-linked polyethylene halogen free	HF XLPE	90	250
- based upon rubber silicon halogen free	HF S 95	95	350 (2)
- based upon cross-linked polyolefin material for halogen free cable (1)	HF 90	90	250
(1) Used on sheathed cable only			
(2) This temperature is applicable only to power cables and not appropriate for tinned copper conductors			

Table 5 : Current carrying capacity, in A, in continuous service for cables based on maximum conductor operating temperature of 60°C (ambient temperature 45°C) (1/7/2024)

Nominal section mm ²	Number of conductors		
	1	2	3 or 4
1,5	10	9	7
2,5	17	14	12
4	23	20	16
6	29	25	20
10	40	34	28
16	54	46	38
25	71	60	50
35	88	75	62
50	110	94	77
70	135	115	95
95	164	139	115
120	189	161	132
150	218	185	153
185	248	211	174
240	292	248	204
300	336	286	235
400	d.c.:390 a.c.:380	d.c.:332 a.c.:323	d.c.:273 a.c.:266
500	d.c.:450 a.c.:430	d.c.:383 a.c.:366	d.c.:315 a.c.:301
600	d.c.:520 a.c.:470	d.c.:442 a.c.:400	d.c.:364 a.c.:329

Table 6 : Current carrying capacity, in A, in continuous service for cables based on maximum conductor operating temperature of 70°C (ambient temperature 45°C) (1/7/2024)

Nominal section mm ²	Number of conductors		
	1	2	3 or 4
1,5	15	13	11
2,5	21	18	15
4	29	25	20
6	37	31	26
10	51	43	36
16	68	58	48
25	90	77	63
35	111	94	78
50	138	117	97
70	171	145	120
95	207	176	145
120	239	203	167
150	275	234	193
185	313	266	219
240	369	314	258
300	424	360	297
400	d.c.:500 a.c.:490	d.c.:425 a.c.:417	d.c.:350 a.c.:343
500	d.c.:580 a.c.:550	d.c.:493 a.c.:468	d.c.:406 a.c.:385
600	d.c.:670 a.c.:610	d.c.:570 a.c.:519	d.c.:467 a.c.:427

Table 7 : Current carrying capacity, in A, in continuous service for cables based on maximum conductor operating temperature of 85°C (ambient temperature 45°C) (1/7/2024)

Nominal section mm ²	Number of conductors		
	1	2	3 or 4
1,5	21	18	15
2,5	28	24	20
4	38	32	27
6	49	42	34
10	67	57	47
16	91	77	64
25	120	102	84
35	148	126	104
50	184	156	129
70	228	194	160
95	276	235	193
120	319	271	223
150	367	312	257
185	418	355	293
240	492	418	344
300	565	480	396
400	d.c.:650 a.c.:630	d.c.:553 a.c.:536	d.c.:455 a.c.:441
500	d.c.:740 a.c.:680	d.c.:629 a.c.:578	d.c.:518 a.c.:476
600	d.c.:840 a.c.:740	d.c.:714 a.c.:629	d.c.:588 a.c.:518

Table 8 : Current carrying capacity, in A, in continuous service for cables based on maximum conductor operating temperature of 90°C (ambient temperature 45°C) (1/7/2024)

Nominal section mm ²	Number of conductors		
	1	2	3 or 4
1,5	23	20	16
2,5	40	26	21
4	51	34	28
6	52	44	36
10	72	61	50
16	96	82	67
25	127	108	89
35	157	133	110
50	196	167	137
70	242	206	169
95	293	249	205
120	339	288	237
150	389	331	272

Nominal section mm ²	Number of conductors		
	1	2	3 or 4
185	444	377	311
240	522	444	365
300	601	511	421
400	d.c.:690 a.c.:670	d.c.:587 a.c.:570	d.c.:483 a.c.:469
500	d.c.:780 a.c.:720	d.c.:663 a.c.:612	d.c.:546 a.c.:504
600	d.c.:890 a.c.:780	d.c.:757 a.c.:663	d.c.:623 a.c.:546

Table 9 : Current carrying capacity, in A, in continuous service for cables based on maximum conductor operating temperature of 95°C (ambient temperature 45°C) (1/7/2024)

Nominal section mm ²	Number of conductors		
	1	2	3 or 4
1,5	26	22	18
2,5	32	27	22
4	43	37	30
6	55	47	39
10	76	65	53
16	102	87	71
25	135	115	95
35	166	141	116
50	208	177	146
70	256	218	179
95	310	264	217
120	359	305	251
150	412	350	288
185	470	400	329
240	553	470	387
300	636	541	445
400	d.c.:760 a.c.:725	d.c.:646 a.c.:616	d.c.:532 a.c.:508
500	d.c.:875 a.c.:810	d.c.:744 a.c.:689	d.c.:612 a.c.:567
600	d.c.:1010 a.c.:900	d.c.:859 a.c.:765	d.c.:707 a.c.:630

9.9.6 Where a cable is intended to supply a short-time load for 1/2-hour or 1-hour service (e.g. mooring winches or bow thruster propellers), the current carrying capacity obtained from Tab 5 to Tab 9 may be increased by applying the corresponding correction factors given in Tab 11.

In no case is a period shorter than 1/2-hour to be used, whatever the effective period of operation.

9.9.7 For supply cables to single services for intermittent loads (e.g. cargo winches or machinery space cranes), the current carrying capacity obtained from Tab 5 to Tab 9 may

be increased by applying the correction factors given in Tab 12.

The correction factors are calculated with rough approximation for periods of 10 minutes, of which 4 minutes with a constant load and 6 minutes without load.

9.10 Minimum nominal cross-sectional area of conductors

9.10.1 In general the minimum allowable conductor cross-sectional areas are those given in Tab 13.

9.10.2 The nominal cross-sectional area of the neutral conductor in three-phase distribution systems is to be equal to at least 50% of the cross-sectional area of the phases, unless the latter is less than or equal to 16 mm². In such case the cross-sectional area of the neutral conductor is to be equal to that of the phase.

9.10.3 For the nominal cross-sectional area of:

- earthing conductors, see Sec 12, [2.3]
- earthing connections for distribution systems, see Sec 12, [2.5].

9.11 Choice of cables

9.11.1 The rated voltage of any cable is to be not lower than the nominal voltage of the circuit for which it is used.

9.11.2 The nominal cross-sectional area of each cable is to be sufficient to satisfy the following conditions with reference to the maximum anticipated ambient temperature:

- the current carrying capacity is to be not less than the highest continuous load carried by the cable
- the voltage drop in the circuit, by full load on this circuit, is not to exceed the specified limits
- the cross-sectional area calculated on the basis of the above is to be such that the temperature increases which may be caused by overcurrents or starting transients do not damage the insulation.

9.11.3 The highest continuous load carried by a cable is to be calculated on the basis of the power requirements and of the diversity factor of the loads and machines supplied through that cable.

9.11.4 When the conductors are carrying the maximum nominal service current, the voltage drop from the main or emergency switchboard busbars to any point in the installation is not to exceed 6% of the nominal voltage.

For battery circuits with supply voltage less than 55 V, this value may be increased to 10%.

For the circuits of navigation lights, the voltage drop is not to exceed 5% of the rated voltage under normal conditions.

Table 10 : Correction factors for various ambient air temperatures (Reference ambient temperature of 45°C) (1/7/2024)

Maximum rated conductor temperature, in °C	Correction factors for ambient air temperature of:										
	35°C	40°C	45°C	50°C	55°C	60°C	65°C	70°C	75°C	80°C	85°C
60	1,29	1,15	1,00	0,82	-	-	-	-	-	-	-
65	1,22	1,12	1,00	0,87	0,71	-	-	-	-	-	-
70	1,18	1,10	1,00	0,89	0,77	0,63	-	-	-	-	-
75	1,15	1,08	1,00	0,91	0,82	0,71	0,58	-	-	-	-
80	1,13	1,07	1,00	0,93	0,85	0,76	0,65	0,53	-	-	-
85	1,12	1,06	1,00	0,94	0,87	0,79	0,71	0,61	0,50	-	-
90	1,10	1,05	1,00	0,94	0,88	0,82	0,74	0,67	0,58	0,47	-
95	1,10	1,05	1,00	0,95	0,89	0,84	0,77	0,71	0,63	0,55	0,45

Table 11 : Correction factors for short-time loads

½ -hour service		1-hour service		Correlation factor
Sum of nominal cross-sectional areas of all conductors in the cable, in mm ²		Sum of nominal cross-sectional areas of all conductors in the cable, in mm ²		
Cables with metallic sheath and armoured cables	Cables with non-metallic sheath and non-armoured cables	Cables with metallic sheath and armoured cables	Cables with non-metallic sheath and non-armoured cables	
up to 20	up to 75	up to 80	up to 230	1,06
21-41	76-125	81-170	231-400	1,10
41-65	126-180	171-250	401-600	1,15
66-95	181-250	251-430	601-800	1,20

½ -hour service		1-hour service		Correlation factor
Sum of nominal cross-sectional areas of all conductors in the cable, in mm ²		Sum of nominal cross-sectional areas of all conductors in the cable, in mm ²		
Cables with metallic sheath and armoured cables	Cables with non-metallic sheath and non-armoured cables	Cables with metallic sheath and armoured cables	Cables with non-metallic sheath and non-armoured cables	
96-135	251-320	431-600	-	1,25
136-180	321-400	601-800	-	1,30
181-235	401-500	-	-	1,35
236-285	501-600	-	-	1,40
286-350	-	-	-	1,45

Table 12 : Correction factors for intermittent service

Sum of nominal cross sectional areas of all conductors in the cable, in mm ²		Correction factor
Cables with metallic sheath and armoured cables	Cables without metallic sheath and non-armoured cables	
	$S \leq 5$	1,10
	$5 < S \leq 8$	1,15
	$8 < S \leq 16$	1,20
$S \leq 4$	$16 < S \leq 825$	1,25
$4 < S \leq 7$	$25 < S \leq 42$	1,30
$7 < S \leq 17$	$42 < S \leq 72$	1,35
$17 < S \leq 42$	$72 < S \leq 140$	1,40
$42 < S \leq 110$	$140 < S$	1,45
$110 < S$	-	1,50

10 Electrical installations in hazardous areas

10.1 Electrical equipment

10.1.1 No electrical equipment is to be installed in hazardous areas unless the Society is satisfied that such equipment is:

- essential for operational purposes,
- of a type which will not ignite the mixture concerned,
- appropriate to the space concerned, and
- appropriately certified for safe usage in the dusts, vapours or gases likely to be encountered.

10.1.2 Where electrical equipment of a safe type is permitted in hazardous areas it is to be selected with due consideration to the following:

- a) risk of explosive dust concentration; see Sec 2, [6.2]:
 - degree of protection of the enclosure
 - maximum surface temperature
- b) risk of explosive gas atmosphere; see Sec 2, [6.1]:
 - explosion group
 - temperature class.

10.1.3 Where electrical equipment is permitted in hazardous areas, all switches and protective devices are to interrupt all poles or phases and, where practicable, to be located in a non-hazardous area unless specifically permitted otherwise.

Such switches and equipment located in hazardous areas are to be suitably labelled for identification purposes.

10.1.4 For electrical equipment installed in Zone 0 hazardous areas, only the following types are permitted:

- certified intrinsically-safe apparatus Ex(ia)
- simple electrical apparatus and components (e.g. thermocouples, photocells, strain gauges, junction boxes, switching devices), included in intrinsically-safe circuits of category “ia” not capable of storing or generating electrical power or energy in excess of limits stated in the relevant rules, and accepted by the appropriate authority
- equipment specifically designed and certified by the appropriate authority for use in Zone 0.

Table 13 : Minimum nominal cross-sectional areas

Service	Nominal cross-sectional area	
	external wiring mm ²	internal wiring mm ²
Power, heating and lighting systems	1,0	1,0
Control circuits for power plant	1,0	1,0
Control circuits other than those for power plant	0,75	0,5
Control circuits for telecommunications, measurement, alarms	0,5	0,2
Telephone and bell equipment, not required for the safety of the ship or crew calls	0,2	0,1
Bus and data cables	0,2	0,1

10.1.5 For electrical equipment installed in Zone 1 hazardous areas, only the following types are permitted:

- any type that may be considered for Zone 0
- certified intrinsically-safe apparatus Ex(ib)
- simple electrical apparatus and components (e.g. thermocouples, photocells, strain gauges, junction boxes, switching devices), included in intrinsically-safe circuits of category "ib" not capable of storing or generating electrical power or energy in excess of limits stated in the relevant rules, and accepted by the appropriate authority
- certified flameproof Ex(d)
- certified pressurised Ex(p)
- certified increased safety Ex(e)
- certified encapsulated Ex(m)
- certified sand filled Ex(q)
- certified specially Ex(s)
- through runs of cable.

10.1.6 (1/1/2022)

For electrical equipment installed in Zone 2 hazardous areas, only the following types are permitted:

- any type that may be considered for Zone 1
- tested specially for Zone 2 (e.g. type "n" protection)
- pressurised, and accepted by the appropriate authority
- encapsulated, and accepted by the appropriate authority
- the type which ensures the absence of sparks and arcs and of "hot spots" during its normal operation (electrical equipment having an enclosure of at least IP55).

10.1.7 When apparatus incorporates a number of types of protection, it is to be ensured that all are suitable for use in the zone in which it is located.

10.2 Electrical cables

10.2.1 Electrical cables are not to be installed in hazardous areas except as specifically permitted or when associated with intrinsically safe circuits.

10.2.2 (1/7/2003)

All cables installed in Zone 0, Zone 1 and weather exposed areas classified Zone 2 are to be sheathed with at least one of the following:

- a non-metallic impervious sheath in combination with braiding or other metallic covering
- a copper or stainless steel sheath (for mineral insulated cables only).

10.2.3 All cables installed in non-weather exposed Zone 2 areas are to be provided with at least a non-metallic external impervious sheath.

10.2.4 Cables of intrinsically safe circuits are to have a metallic shielding with at least a non-metallic external impervious sheath.

10.2.5 The circuits of a category "ib" intrinsically safe system are not to be contained in a cable associated with a category "ia" intrinsically safe system required for a hazardous area in which only category "ia" systems are permitted.

10.3 Electrical installations in battery rooms

10.3.1 (1/7/2003)

Only intrinsically safe apparatus and certified safe type lighting fittings may be installed in compartments assigned solely to large vented storage batteries; see Sec 11, [6.2.1].

The associated switches are to be installed outside such spaces.

Electric ventilator motors are to be outside ventilation ducts and, if within 3 m of the exhaust end of the duct, they are to be of an explosion-proof safe type. The impeller of the fan is to be of the non-sparking type.

Overcurrent protective devices are to be installed as close as possible to, but outside of, battery rooms.

Electrical cables other than those pertaining to the equipment arranged in battery rooms are not permitted.

Electrical equipment for use in battery rooms is to have minimum explosion group IIC and temperature class T1.

10.3.2 Standard marine electrical equipment may be installed in compartments assigned solely to valve-regulated sealed storage batteries.

10.3.3 (1/7/2004)

Where vented (see Note 1) type batteries replace valve-regulated sealed (see Note 2) types, the requirements of Sec 11 are to be complied with.

Note 1: A vented battery is one in which the cells have a cover provided with an opening through which products of electrolysis and evaporation are allowed to escape freely from the cells to atmosphere.

Note 2: A valve-regulated battery is one in which cells are closed but have an arrangement (valve) which allows the escape of gas if the internal pressure exceeds a predetermined value.

10.4 Electrical equipment allowed in paint stores and in enclosed spaces leading to paint stores

10.4.1 General (1/1/2022)

Electrical equipment is to be installed in paint stores and in ventilation ducts serving such spaces only when it is essential for operational services

Certified safe type equipment of the following type is acceptable:

- a) intrinsically safe Exi
- b) flameproof Exd
- c) pressurised Exp
- d) increased safety Exe
- e) special protection Exs

Cables (through-runs or terminating cables) of armoured type or installed in metallic conduits are to be used.

10.4.2 Minimum Requirements (1/1/2022)

The minimum requirements for certified safe type equipment are as follows:

- explosion group II B
- temperature class T3.

Note 1: The paint stores and inlet and exhaust ventilation ducts under [10.4.1] are classified as Zone 1 and areas on open deck under [10.4.3] b) as Zone 2, as defined in IEC 60092-502 (Electrical Installation in ships-part 502: Tankers-special features).

Note 2: A watertight door may be considered as being gas-tight.

10.4.3 Special requirements (1/1/2022)

- a) Switches, protective devices and motor control gear of electrical equipment installed in a paint store are to interrupt all poles or phases and are preferably to be located in a non-hazardous space.
- b) In areas on open deck within 1m of inlet and exhaust ventilation openings or within 3 m of exhaust mechanical ventilation outlets, the following electrical equipment may be installed:
 - electrical equipment with the type of protection as permitted in paint stores;
 - equipment of protection class Exn;
 - appliances which do not generate arcs in service and whose surface does not reach unacceptably high temperature;
 - appliances with simplified pressurised enclosures or vapour-proof enclosures (electrical equipment

having an enclosure of at least IP55) whose surface does not reach unacceptably high temperature; or

- cables as specified in [10.4.1].

c) The enclosed spaces giving access to the paint store may be considered as non-hazardous, provided that:

- the door to the paint store is a gas-tight door with self-closing devices without holding back arrangements;
- the paint store is provided with an acceptable, independent, natural ventilation system ventilated from a safe area; and
- warning notices are fitted adjacent to the paint store entrance stating that the store contains flammable liquids.

10.5 Electrical installations in stores for welding gas (acetylene) bottles

10.5.1 The following equipment may be installed in stores for welding gas bottles provided that it is of a safe type appropriate for Zone 1 area installation:

- lighting fittings
- ventilator motors where provided.

10.5.2 Electrical cables other than those pertaining to the equipment arranged in stores for welding gas bottles are not permitted.

10.5.3 Electrical equipment for use in stores for welding gas bottles is to have minimum explosion group IIC and temperature class T2.

10.6 Special ships

10.6.1 For installations in hazardous areas in:

- oil tankers, chemical tankers and liquefied gas carriers, see Pt E, Ch 7, Sec 5, Pt E, Ch 8, Sec 10 or Pt E, Ch 9, Sec 10
- ships arranged with spaces for the carriage of vehicles, see Pt E, Ch 1, Sec 4 or Pt E, Ch 12, Sec 4.

11 Recording of the Type, Location and Maintenance Cycle of Batteries

11.1 Battery schedule

11.1.1 (1/7/2004)

Where batteries are fitted for use for essential and emergency services, a schedule of such batteries is to be compiled and maintained. The schedule, required in Sec 1,

Tab 1, is to include at least the following information regarding the battery(ies):

- type and Manufacturer's type designation
- voltage and ampere-hour rating
- location
- equipment and/or system(s) served
- maintenance/replacement cycle dates
- date(s) of last maintenance and/or replacement
- for replacement batteries in storage, the date of manufacture and shelf life.

Note 1: Shelf life is the duration of storage under specified conditions at the end of which a battery retains the ability to give a specified performance.

SECTION 4 ROTATING MACHINES

1 Constructional and operational requirements for generators and motors

1.1 Mechanical construction

1.1.1 (1/7/2001)

Insulating materials, insulated windings and construction of electrical machines are to conform to the relevant requirements of Sec 2, [4] and Sec 2, [5].

1.1.2 Shafts are to be made of material complying with the provisions of Pt D, Ch 2, Sec 3 or, where rolled products are allowed in place of forgings, with those of Pt D, Ch 2, Sec 1.

1.1.3 Where welded parts are foreseen on shafts and rotors, the provisions of Part D, Chapter 5 are to apply.

1.1.4 Sleeve bearings are to be efficiently and automatically lubricated at all running speeds.

Provision is to be made for preventing the lubricant from gaining access to windings or other insulated or bare current carrying parts.

1.1.5 Means are to be provided to prevent bearings from being damaged by the flow of currents circulating between them and the shaft. According to the Manufacturer's requirements, electrical insulation of at least one bearing is to be considered.

1.1.6 For surface-cooled machines with an external fan installed on the open deck, adequate protection of the fan against icing is to be provided.

1.1.7 When liquid cooling is used, the coolers are to be so arranged as to avoid entry of water into the machine, whether by leakage or condensation in the heat exchanger, and provision is to be made for the detection of leakage.

1.1.8 (1/7/2013)

Motors cooled with a water jacket can be accepted for both propulsion and auxiliary services, however the use of water jacket cooled electric motors for propulsion is limited to installations with motor redundancy.

In motors cooled with a water jacket, internal water leakage sensors are to be provided.

The water jacket is to be pressure tested at not less than 1,5 times the working pressure after final machining.

1.1.9 Rotating machines whose ventilation or lubrication system efficiency depends on the direction of rotation are to be provided with a warning plate.

1.2 Sliprings, commutators and brushes

1.2.1 Sliprings and commutators with their brushgear are to be so constructed that undue arcing is avoided under all normal load conditions.

1.2.2 The working position of brushgear is to be clearly and permanently marked.

1.2.3 Sliprings, commutators and brushgear are to be readily accessible for inspection, repairs and maintenance.

1.3 Terminal connectors

1.3.1 Suitable, fixed terminal connectors are to be provided in an accessible position for connection of the external cables.

1.3.2 All terminal connectors are to be clearly identified with reference to a diagram.

1.3.3 The degree of protection of terminal boxes is to be adequate to that of the machine.

1.4 Electrical insulation

1.4.1 Insulating materials for windings and other current carrying parts are to comply with the requirements of Sec 2, [4.2] and Sec 2, [4.3].

2 Special requirements for generators

2.1 Prime movers, speed governors and overspeed protection

2.1.1 Prime movers for generators are to comply with the relevant requirements of Ch 1, Sec 2, [4.7].

2.1.2 When generators are to operate in parallel, the characteristics of speed governors are to comply with the provisions of [2.2].

2.2 A.c. generators

2.2.1 Alternators are to be so constructed that, when started up, they take up the voltage without the aid of an external electrical power source.

Where these provisions are not complied with, the external electrical power source is to be constituted by a battery installation in accordance with the requirements for electrical starting systems of auxiliary machinery (see Ch 1, Sec 2).

2.2.2 The voltage wave form is to be approximately sinusoidal, with a maximum deviation from the sinusoidal fundamental curve of 5% of the peak value.

2.2.3 Each alternator is to be provided with automatic means of voltage regulation.

2.2.4 For a.c. generating sets operating in parallel, the governing characteristics of the prime movers are to be such that, within the limits of 20% and 100% total load, the load on any generating set will not normally differ from its proportionate share of the total load by more than 15% of the rated power in kW of the largest machine or 25% of the rated power in kW of the individual machine in question, whichever is the lesser.

2.2.5 For a.c. generating sets intended to operate in parallel, means are to be provided to regulate the governor so as to permit an adjustment of load not exceeding 5% of the rated load at normal frequency.

2.2.6 When a.c. generators are operated in parallel, the reactive loads of the individual generating sets are not to differ from their proportionate share of the total reactive load by more than 10% of the rated reactive power of the largest machine, or 25% of that of the smallest machine, whichever is the lesser.

3 Testing of rotating machines

3.1 General

3.1.1 (1/1/2002)

All machines are to be tested by the Manufacturer

3.1.2 (1/1/2002)

Manufacturer's test records are to be provided for machines for essential services, for other machines they are to be available upon request.

3.1.3 (1/1/2002)

All tests are to be carried out according to IEC 60092-301.

3.1.4 (1/1/2002)

All a.c. generators having rated power of 100 kVA and above, all d.c. generators having rated power of 100 kW and above, and all a.c./d.c. motors having rated power of 100 kW and above, intended for essential services are to be surveyed by the Society during testing and, if appropriate, during manufacturing.

Note 1: An Alternative Certification Scheme may be agreed by the Society with the Manufacturer whereby the attendance of the Surveyor will not be required as indicated above.

3.2 Shaft material

3.2.1 (1/1/2002)

Shaft material for electric propulsion motors and for main engine driven generators where the shaft is part of the propulsion shafting is to be certified by the Society.

3.2.2 (1/1/2002)

Shaft material for other machines is to be in accordance with recognised international or national standards (See [1.1.2]).

3.3 Tests

3.3.1 (1/7/2002)

Type tests are to be carried out on a prototype machine or on the first of a batch of machines, and routine tests carried out on subsequent machines in accordance with Tab 1.

Note 1: Test requirements may differ for shaft generators, special purpose machines and machines of novel construction.

Table 1 : Tests to be carried out on electrical rotating machines (1/1/2002)

No.	Tests	a.c. Generators		Motors	
		Type test (1)	Routine test (2)	Type test (1)	Routine test (2)
1	Examination of the technical documentation, as appropriate, and visual inspection	X	X	X	X
2	Insulation resistance measurement	X	X	X	X
3	Winding resistance measurement	X	X	X	X
4	Verification of the voltage regulation system	X	X (3)		
5	Rated load test and temperature rise measurement	X		X	
6	Overload/overcurrent test	X	X (4)	X	X (4)
7	Verification of steady short-circuit conditions (5)	X			
8	Overspeed test	X	X	X (6)	X (6)
9	Dielectric strength test	X	X	X	X
10	No load test	X	X	X	X
11	Verification of degree of protection	X		X	

No.	Tests	a.c. Generators		Motors	
		Type test (1)	Routine test (2)	Type test (1)	Routine test (2)
12	Verification of bearings	X	X	X	X
<p>(1) Type tests on prototype machine or tests on at least the first of a batch of machines.</p> <p>(2) The report on routinely tested machines is to contain the Manufacturer's serial number of the machine which has been type tested and the test result.</p> <p>(3) Only functional test of voltage regulator system.</p> <p>(4) Only applicable for machine of essential services rated above 100kW/kVA.</p> <p>(5) Verification of steady short circuit condition applies to synchronous generators only.</p> <p>(6) Not applicable for squirrel cage motors.</p>					

Table 2 : Minimum insulation resistance (1/1/2002)

Rated voltage U_n , in V	Minimum test voltage, in V	Minimum insulation resistance, in $M\Omega$
$U_n = 250$	$2 U_n$	1
$250 < U_n \leq 1000$	500	1
$1000 < U_n \leq 7200$	1000	$U_n/1000 + 1$
$7200 < U_n \leq 15000$	5000	$U_n/1000 + 1$

4 Description of the test

4.1 Examination of the technical documentation, as appropriate, and visual inspection

4.1.1 Examination of the technical documentation (1/1/2002)

Technical documentation of machines rated at 100kW (kVA) and over is to be available for examination by the Surveyor.

4.1.2 Visual inspection (1/1/2002)

A visual examination of the machine is to be made to ensure, as far as is practicable, that it complies with the technical documentation.

4.2 Insulation resistance measurement

4.2.1 (1/1/2002)

Immediately after the high voltage tests the insulation resistances are to be measured using a direct current insulation tester between:

- all current carrying parts connected together and earth,
- all current carrying parts of different polarity or phase, where both ends of each polarity or phase are individually accessible.

The minimum values of test voltages and corresponding insulation resistances are given in Tab 2. The insulation resistance is to be measured close to the operating temperature, or an appropriate method of calculation is to be used.

4.3 Winding resistance measurement

4.3.1 (1/1/2002)

The resistances of the machine windings are to be measured and recorded using an appropriate bridge method or voltage and current method.

4.4 Verification of the voltage regulation system

4.4.1 (1/1/2017)

The alternating current generator, together with its voltage regulation system, at all loads from no load running to full load, is to be able to keep the rated voltage at the rated power factor under steady conditions within $\pm 2.5\%$. These limits may be increased to $\pm 3.5\%$ for emergency sets.

4.4.2 (1/1/2002)

When the generator is driven at rated speed, giving its rated voltage, and is subjected to a sudden change of symmetrical load within the limits of specified current and power factor, the voltage is not to fall below 85% nor exceed 120% of the rated voltage

4.4.3 (1/1/2002)

The voltage of the generator is then to be restored to within plus or minus 3% of the rated voltage for the main generator sets in not more than 1.5 s. For emergency sets, these values may be increased to plus or minus 4% in not more than 5 s.

4.4.4 (1/1/2017)

In the absence of precise information concerning the maximum values of the sudden loads, the following conditions may be assumed: 60% of the rated current with a power factor of between 0.4 lagging and zero to be suddenly switched on with the generator running at no load, and then switched off after steady - state conditions have been reached. Subject to Classification Society's approval, such voltage regulation during transient conditions may be cal-

culated values based on the previous type test records, and need not to be tested during factory testing of a generator.

4.5 Rated load test and temperature rise measurements

4.5.1 (1/7/2022)

The temperature rises are to be measured at the rated output, voltage and frequency and for the duty for which the machine is rated and marked in accordance with the testing methods specified in IEC 60034-1, or by means of a combination of other tests.

The limits of temperature rise are those specified in IEC 60034-1 adjusted as necessary for the ambient reference temperatures specified in Sec 2.

4.6 Overload/overcurrent tests

4.6.1 (1/1/2002)

Overload test is to be carried out as a type test for generators as proof of overload capability of generators and the excitation system, for motors as proof of momentary excess torque as required in IEC 60034-1. The overload test can be replaced at a routine test by an overcurrent test. The overcurrent test is to be proof of the current capability of the windings, wires, connections etc. of each machine. The overcurrent test can be performed at reduced speed (motors) or at short-circuit (generators).

4.6.2 (1/1/2002)

In the case of machines for special uses (e.g. for windlasses), overload values other than the above may be considered.

4.7 Verification of steady short-circuit conditions

4.7.1 (1/1/2017)

It is to be verified that under steady state short-circuit conditions, the generator with its voltage regulating system is capable of maintaining, without sustaining any damage, a current of at least three times the rated current for a duration of at least 2 s or, where precise data is available, for a duration of any time delay which may be fitted in a tripping device for discrimination purposes.

In order to provide sufficient information to the party responsible for determining the discrimination settings in the distribution system where the generator is going to be used, the generator manufacturer shall provide documentation showing the transient behaviour of the short circuit current upon a sudden short-circuit occurring when excited, and running at nominal speed. The influence of the automatic voltage regulator shall be taken into account, and the setting parameters for the voltage regulator shall be noted together with the decrement curve. Such a decrement curve shall be available when the setting of the distribution system's short-circuit protection is calculated. The decrement curve need not be based on physical testing. The manufacturers simulation model for the generator and the voltage

regulator may be used where this has been validated through the previous type test on the same model.

4.8 Overspeed test

4.8.1 (1/1/2002)

Machines are to withstand the overspeed test as specified in IEC 60034-1. This test is not applicable for squirrel cage motors.

4.9 Dielectric strength test

4.9.1 (1/1/2002)

New and completed rotating machines are to withstand a dielectric test as specified in IEC 60034-1.

4.9.2 (1/1/2002)

For high voltage machines an impulse test is to be carried out on the coils according to Sec 13.

4.9.3 (1/1/2002)

When it is necessary to perform an additional high voltage test, this is to be carried out after any further drying, with a test voltage of 80% of that specified in IEC 60034-1.

4.9.4 (1/1/2002)

Completely rewound windings of used machines are to be tested with the full test voltage applied in the case of new machines.

4.9.5 (1/1/2002)

Partially rewound windings are to be tested at 75% of the test voltage required for new machines. Prior to the test, the old part of the winding is to be carefully cleaned and dried.

4.9.6 (1/1/2002)

Following cleaning and drying, overhauled machines are to be subjected to a test at a voltage equal to 1,5 times the rated voltage, with a minimum of 500 V if the rated voltage is less than 100 V, and with a minimum of 1000 V if the rated voltage is equal to or greater than 100 V.

4.9.7 (1/1/2002)

A repetition of the high voltage test for groups of machines and apparatus is to be avoided if possible, but if a test on an assembled group of several pieces of new apparatus, each of which has previously passed its high voltage test, is performed, the test voltage to be applied to such assembled group is 80% of the lowest test voltage appropriate for any part of the group.

Note 1: For windings of one or more machines connected together electrically, the voltage to be considered is the maximum voltage that occurs in relation to earth.

4.10 No load test

4.10.1 (1/1/2002)

Machines are to be operated at no load and rated speed whilst being supplied at rated voltage and frequency as a motor while generators are to be driven by a suitable means and excited to give rated terminal voltage.

During the running test, the vibration of the machine and operation of the bearing lubrication system, if appropriate, are to be checked.

4.11 Verification of degree of protection

4.11.1 (1/1/2002)

As specified in IEC 60034-5.

4.12 Verification of bearings

4.12.1 (1/1/2002)

Upon completion of the above tests, machines which have sleeve bearings are to be opened upon request for examination by the Surveyor, to establish that the shaft is correctly seated in the bearing shells.

5 Requirements for AC Generating sets

5.1 General

5.1.1 (1/7/2020)

This Section provides requirements for AC Generating sets (i.e. Reciprocating Internal Combustion engines^{a)}, b), alternators^{c)} and couplings) in addition to those stated Ch 1, Sec 2; Ch 1, Sec 16; Ch 1, App 1 and Sec 4.

a) Reciprocating Internal Combustion engines are to comply with the requirements in Ch 1, Sec 2; Ch 1, Sec 16 and Ch 1, App 1.

b) The Reciprocating Internal Combustion engine speed governor and overspeed protective device are to comply with the requirements of Ch 1, Sec 2, [4.7.3] to [4.7.7].

c) Alternators are to comply with the requirements in Sec 4.

5.1.2 (1/7/2020)

The requirements are applicable to AC generating sets driven by reciprocating internal combustion engines irrespective of their types (i.e. diesel engine, dual fuel engine, gasfuel engine), except for those sets consisting of a propulsion engine which also drives power take off (PTO) generator(s).

5.2 Generating sets - requirements

5.2.1 (1/7/2020)

The generating set shall show torsional vibration levels which are compatible with the allowable limits for the alternator, shafts, coupling and damper.

5.2.2 (1/7/2020)

The coupling selection for the generating set shall take into account the stresses and torques imposed on it by the torsional vibration of the system. Where flexible couplings are adopted, the provisions of Ch 1, Sec 7, [2.5.4] b) and Ch 1, Sec 9, [3.6.3] are to be complied with. The torsional vibration calculations are to be submitted to the Society for approval when the engine power is 110 kW or above.

5.2.3 (1/7/2020)

The rated power shall be appropriate for the actual use of the generator set.

5.2.4 (1/7/2020)

The entity responsible of assembling the generating set shall install a rating plate marked with at least the following information:

(i) the generating set manufacturer's name or mark;

(ii) the set serial number;

(iii) the set date of manufacture (month/year);

(iv) the rated power (both in kW and KVA) with one of the prefixes COP, PRP (or, only for emergency Generating sets, LTP) as defined in ISO 8528-1:2018;

(v) the rated power factor;

(vi) the set rated frequency (Hz);

(vii) the set rated voltage (V Sec 4);

(viii) the set rated current (A);

(ix) the mass (kg).

SECTION 5

TRANSFORMERS

1 Constructional and operational requirements

1.1 Construction

1.1.1 Transformers, except those for motor starting, are to be double wound (two or more separate windings).

1.1.2 Transformers are normally to be of the dry, air-cooled type.

1.1.3 When a forced air cooling system is used, an alarm is to be activated in the event of its failure.

1.1.4 Liquid-cooled transformers may be used provided that:

- the liquid is non-toxic and of a type which does not readily support combustion
- the construction is such that the liquid is not spilled in inclined position
- temperature and pressure relief devices with an alarm are installed
- drip trays or other suitable arrangements for collecting the liquid from leakages are provided
- a liquid gauge indicating the normal liquid level range is fitted.

1.1.5 Transformers are to have enclosures with a degree of protection in accordance with Sec 3, Tab 2.

1.2 Terminals

1.2.1 Suitable fixed terminal connections are to be provided in an accessible position with sufficient space for convenient connection of the external cables.

1.2.2 Terminals are to be clearly identified.

1.3 Short-circuit conditions and parallel operation

1.3.1 In determining the voltage ratio and the impedance voltage of transformers, account is to be taken of the total permitted voltage drop from the main switchboard's busbars to the consumers (see Sec 3, [9.11.4]).

1.3.2 Transformers are to be constructed to withstand, without damage, the thermal and mechanical effects of a secondary terminal short-circuit for 2 s, with rated primary voltage and frequency.

For transformers of 1 MVA and over, this is to be justified with appropriate tests or documentation.

1.3.3 When transformers are so arranged that their secondary windings may be connected in parallel, their winding

connections are to be compatible, their rated voltage ratios are to be equal (with tolerances allowed) and their short-circuit impedance values, expressed as a percentage, are to have a ratio within 0,9 to 1,1.

When transformers are intended for operation in parallel, the rated power of the smallest transformer in the group is to be not less than half of the rated power of the largest transformer in the group.

1.4 Electrical insulation and temperature rise

1.4.1 Insulating materials for windings and other current carrying parts are to comply with the requirements of Sec 2.

1.4.2 All windings of air-cooled transformers are to be suitably treated to resist moisture, air salt mist and oil vapours.

1.4.3 The permissible limits of temperature rise with an ambient air temperature of 45°C for (natural or forced) air-cooled transformers are given in Tab 1. The temperature rises shown for windings refer to measurement by the resistance method while those for the core refer to the thermometer method.

1.4.4 For dry-type transformers cooled with an external liquid cooling system, the permissible limits of temperature rise with a sea water temperature of 32°C are 13°C higher than those specified in Tab 1.

1.4.5 For liquid-cooled transformers, the following temperature rises measured by the resistance method apply:

- 55°C where the fluid is cooled by air
- 68°C where the fluid is cooled by water.

1.5 Insulation tests

1.5.1 Transformers are to be subjected to a high voltage test in accordance with the procedure defined in Sec 4, [4.9].

1.5.2 The test voltage is to be applied between each winding under test and the other windings not under test, core and enclosure all connected together.

Single-phase transformers for use in a polyphase group are to be tested in accordance with the requirements applicable to that group.

1.5.3 The r.m.s. value of the test voltage is to be equal to $2U + 1000$ V, with a minimum of 2500 V, where U is the rated voltage of the winding. The full voltage is to be maintained for 1 minute.

1.5.4 Partially rewound windings are to be tested at 75% of the test voltage required for new machines.

Table 1 : Temperature rise limits for transformers

No.	Part of machine	Temperature rise by class of insulation, in °C				
		A	E	B	F	H
1	Windings	55	70	75	95	120
2	Cores and other parts: a) in contact with the windings b) not in contact with the windings	a) the same values as for the windings b) in no case is the temperature to reach values such as to damage either the core itself or other adjacent parts or materials				

1.5.5 The insulation resistance of a new, clean and dry transformer, measured after the temperature rise test has been carried out (at or near operating temperature) at a voltage equal to 500 V d.c., is to be not less than 5 MΩ.

1.5.6 Transformers are to be subjected to an induced voltage insulation test by applying to the terminals of the winding under test a voltage equal to twice the rated voltage. The duration of the test is to be 60 s for any test frequency f_p up to and including twice the rated frequency f_n .

If the test frequency exceeds twice the rated frequency, the test time in seconds will be $120 f_n/f_p$ with a minimum of 15 s.

2 Testing

2.1 General

2.1.1 On new transformers intended for essential services the tests specified in [2.2] are to be carried out.

2.1.2 The manufacturer is to issue a test report giving, inter alia, information concerning the construction, type, serial number, insulation class and all other technical data relevant to the transformer, as well as the results of the tests required.

Such test reports are to be made available to the Society.

2.1.3 In the case of transformers which are completely identical in rating and in all other constructional details, it will be acceptable for the temperature rise test to be performed on only one transformer.

The results of this test and the serial number of the tested transformer are to be inserted in the test reports for the other transformers.

2.1.4 Where the test procedure is not specified, the requirements of IEC 60076 apply.

2.1.5 (1/7/2004)

The tests and, if appropriate, manufacture of transformers of 100 kVA and over (60 kVA when single phase) intended for essential services are to be attended by a Surveyor of the Society.

Transformers of 5 kVA up to the limit specified above are approved on a case by case basis, at the discretion of the Society, subject to the submission of adequate documentation and routine tests.

Note 1: An Alternative Certification Scheme may be agreed by the Society with the Manufacturer whereby the attendance of the Surveyor will not be required as indicated above.

2.2 Tests on transformers

2.2.1 Tests to be carried out on transformers are specified in Tab 2.

Table 2 : Tests to be carried out on transformers (1/7/2009)

No.	Tests	Type test (1)	Routine test (2)
1	Examination of the technical documentation, as appropriate, and visual inspection (3)	X	X
2	Insulation resistance measurement	X	X
3	High voltage test	X	X
4	Temperature rise measurement	X	
5	Induced voltage test	X	X
6	Voltage ratio	X	X

(1) Type test on prototype transformer or test on at least the first batch of transformers.
(2) The certificates of transformers routine tested are to contain the manufacturer's serial number of the transformer which has been type tested and the test result.
(3) A visual examination is to be made of the transformer to ensure, as far as practicable, that it complies with technical documentation.

SECTION 6

SEMICONDUCTOR CONVERTORS

1 Constructional and operational requirements

1.1 Construction

1.1.1 Semiconductor convertors are generally to comply with the requirements for switchgear assemblies (see Sec 8).

1.1.2 The monitoring and control circuits are generally to comply with the requirements of Chapter 3.

1.1.3 For liquid-cooled convertors the following provisions are to be satisfied:

- liquid is to be non-toxic and of low flammability
- drip trays or other suitable means are to be provided to contain any liquid leakages
- the resistivity of the cooling fluid in direct contact with semiconductor or other current carrying parts is to be monitored and an alarm initiated if the resistivity is outside the specified limits.

1.1.4 Where forced cooling is used, the temperature of the heated cooling medium is to be monitored.

If the temperature exceeds a preset value an alarm is to be given and the shutdown of the convertor is to be activated.

1.1.5 Where forced (air or liquid) cooling is provided, it is to be so arranged that the convertor cannot be or remain loaded unless effective cooling is maintained.

Alternatively, other effective means of protection against overtemperature may be provided.

1.1.6 Stacks of semiconductor elements, and other equipment such as fuses, or control and firing circuit boards etc., are to be so arranged that they can be removed from equipment without dismantling the complete unit.

1.1.7 Semiconductor convertors are to be rated for the required duty having regard to the peak loads, system transient and overvoltage and to be dimensioned so as to withstand the maximum short-circuit currents foreseen at the point of installation for the time necessary to trip the protection of the circuits they supply.

1.2 Protection

1.2.1 Semiconductor elements are to be protected against short-circuit by means of devices suitable for the point of installation in the network.

1.2.2 Overcurrent and overvoltage protection is to be installed to protect the convertor. When the semiconductor convertor is designed to work as an inverter supplying the network in transient periods, precautions necessary to limit the current are to be taken.

1.2.3 Semiconductor convertors are not to cause distortion in the voltage wave form of the power supply at levels exceeding the voltage wave form tolerances at the other user input terminals (see Sec 2, [2.2]).

1.2.4 An alarm is to be provided for tripping of protective devices against overvoltages and overcurrents in electric propulsion convertors and for convertors for the emergency source of power.

1.3 Parallel operation with other power sources

1.3.1 For convertors arranged to operate in parallel with other power sources, load sharing is to be such that under normal operating conditions overloading of any unit does not occur and the combination of paralleled equipment is stable.

1.4 Temperature rise

1.4.1 The permissible limit of temperature rise of the enclosure of the semiconductors is to be assessed on the basis of an ambient air temperature of 45°C or sea water temperature of 32°C for water-cooled elements, taking into account its specified maximum permissible temperature value.

1.4.2 The value of the maximum permissible temperature of the elements at the point where this can be measured (point of reference) is to be stated by the manufacturer.

1.4.3 The value of the mean rated current of the semiconductor element is to be stated by the manufacturer.

1.5 Insulation test

1.5.1 The test procedure is that specified in IEC Publication 60146.

1.5.2 The effective value of the test voltage for the insulation test is to be as shown in Tab 1.

Table 1 : Test voltages for high voltage test on static convertors

$\frac{U_m}{\sqrt{2}} = U$ in V (1)	Test voltage V
$U \leq 60$	600
$60 < U \leq 90$	900
$90 < U$	$2U + 1000$ (at least 2000)
(1) U_m : highest crest value to be expected between any pair of terminals.	

2 Testing

2.1 General

2.1.1 (1/1/2017)

All the convertors are to be subjected to the tests stated in [2.2].

2.1.2 (1/1/2017)

For convertors intended for essential services the manufacturer is to provide a test report, giving information

on the construction, type, serial number and all technical data relevant to the convertor, as well as the results of the tests required; for other convertors the test report is to be made available upon request.

Note 1: An Alternative Certification Scheme may be agreed by the Society with the Manufacturer whereby the attendance of the Surveyor will not be required as indicated above.

2.1.3 In the case of convertors which are completely identical in rating and in all other constructional details, it will be acceptable for the rated current test and temperature rise measurement stipulated in [2.2] not to be repeated.

2.1.4 The tests and, if appropriate, manufacture of convertors of 50 kVA and over intended for essential services are to be attended by a Surveyor of the Society.

2.2 Tests on convertors

2.2.1 Convertors are to be subjected to tests in accordance with Tab 2.

Type tests are the tests to be carried out on a prototype convertor or the first of a batch of convertors, and routine tests are the tests to be carried out on subsequent convertors of a particular type.

2.2.2 Final approval of convertors is to include complete function tests after installation on board, performed with all ship's systems in operation and in all characteristic load conditions.

Table 2 : Tests to be carried out on static convertors

No.	Tests	Type test (1)	Routine test (2)
1	Examination of the technical documentation, as appropriate, and visual inspection (3) including check of earth continuity	X	X
2	Light load function test to verify all basic and auxiliary functions	X	X
3	Rated current test	X	
4	Temperature rise measurement	X	
5	Insulation test (dielectric strength test and insulation resistance measurement)	X	X
6	Protection of the convertors in case of failure of forced cooling system	X	X
(1) Type test on prototype convertor or test on at least the first batch of convertors.			
(2) The certificates of convertors routine tested are to contain the manufacturer's serial number of the convertor which has been type tested and the test result.			
(3) A visual examination is to be made of the convertor to ensure, as far as practicable, that it complies with technical documentation.			

SECTION 7

STORAGE BATTERIES, CHARGERS, UNINTERRUPTIBLE POWER SYSTEMS AND FUEL CELLS

1 Constructional requirements for batteries

1.1 General

1.1.1 The requirements of this Article apply to permanently installed storage batteries (not to portable batteries).

1.1.2 (1/1/2019)

Storage batteries may be of the lead-acid or nickel-alkaline type, due consideration being given to the suitability for any specific application.

The use of batteries other than Lead-acid or alkaline batteries is allowed subject to the compliance of the battery system and its installation to the requirements given in App 2.

Storage batteries of satisfactorily proven design (e.g. silver/zinc) may be accepted provided they are suitable for shipboard use to the satisfaction of the Society.

1.1.3 Cells are to be assembled in suitable crates or trays equipped with handles for convenient lifting.

1.2 Vented batteries

1.2.1 Vented batteries are those in which the electrolyte can be replaced and freely releases gas during periods of charge and overcharge.

1.2.2 Vented batteries are to be constructed to withstand the movement of the ship and the atmosphere (salt mist, oil etc.) to which they may be exposed.

1.2.3 Battery cells are to be so constructed as to prevent spilling of electrolyte at any inclination of the battery up to 40° from the vertical.

1.2.4 It is to be possible to check the electrolyte level and the pH.

1.3 Valve-regulated sealed batteries

1.3.1 Valve-regulated sealed batteries are batteries whose cells are closed under normal conditions but which have an arrangement which allows the escape of gas if the internal pressure exceeds a predetermined value. The cells cannot normally receive addition to the electrolyte.

Note 1: The cells of batteries which are marketed as "sealed" or "maintenance free" are fitted with a pressure relief valve as a safety

precaution to enable uncombined gas to be vented to the atmosphere; they should more properly be referred to as valve-regulated sealed batteries. In some circumstances the quantity of gas vented can be up to 25% of the equivalent vented design. The design is to take into consideration provision for proper ventilation.

1.3.2 Cell design is to minimise risks of release of gas under normal and abnormal conditions.

1.4 Tests on batteries

1.4.1 The battery autonomy is to be verified on board in accordance with the operating conditions.

2 Constructional requirements for chargers

2.1 Characteristics

2.1.1 Chargers are to be adequate for the batteries for which they are intended and provided with a voltage regulator.

2.1.2 In the absence of indications regarding its operation, the battery charger is to be such that the completely discharged battery can be recharged to 80% capacity within a period of 10 hours without exceeding the maximum permissible charging current. A charging rate other than the above (e.g. fully charged within 6 hours for batteries for starting of motors) may be required in relation to the use of the battery.

2.1.3 For floating service or for any other condition where the load is connected to the battery while it is on charge, the maximum battery voltage is not to exceed the safe value of any connected apparatus.

Note 1: Consideration is to be given to the temperature variation of the batteries.

2.1.4 The battery charger is to be designed so that the charging current is set within the maximum current allowed by the manufacturer when the battery is discharged and the floating current to keep the battery fully charged.

2.1.5 Trickle charging to neutralise internal losses is to be provided. An indication is to be provided to indicate a charging voltage being present at the charging unit.

2.1.6 Protection against reversal of the charging current is to be provided.

2.1.7 Battery chargers are to be constructed to simplify maintenance operation. Indications are to be provided to visualise the proper operation of the charger and for troubleshooting.

2.2 Tests on chargers

2.2.1 Battery chargers are to be subjected to tests in accordance with Tab 1.

Type tests are the tests to be carried out on a prototype charger or the first of a batch of chargers, and routine tests are the tests to be carried out on subsequent chargers of a particular type.

2.2.2 (1/7/2004)

The tests of battery chargers of 50 kVA and over intended for essential services are to be attended by a Surveyor of the Society.

Note 1: An Alternative Certification Scheme may be agreed by the Society with the Manufacturer whereby the attendance of the Surveyor will not be required as indicated above.

3 Uninterruptible power system (UPS) units as alternative and/or transitional power

3.1 Application

3.1.1 (1/1/2023)

These requirements for UPS units apply when providing an alternative power supply or transitional power supply to services as defined in Pt E, Ch 11, Sec 5, [2] and Sec 3, [2.3] and [3.7] and when providing an alternative power supply to primary essential services as defined in Sec 1, [3.3.1].

A UPS unit complying with these requirements may provide an alternative power supply as an accumulator battery in terms of being an independent power supply for services defined in Pt E, Ch 11, Sec 5, [2.2.3] or Sec 3, [3.7.3] d) and primary essential services as defined in Sec 1, [3.3.1].

3.2 Definitions

3.2.1 (1/7/2006)

Uninterruptible Power System (UPS) - combination of convertors, switches and energy storage means, for example batteries, constituting a power system for maintaining continuity of load power in case of input power failure

Off-line UPS unit - a UPS unit where under normal operation the output load is powered from the bypass line (raw mains) and only transferred to the inverter if the bypass supply fails or goes outside preset limits. This transition will invariably result in a brief (typically 2 to 10 ms) break in the load supply.

Line interactive UPS unit - an off-line UPS unit where the bypass line switches to stored energy power when the input power goes outside the preset voltage and frequency limits.

On-line UPS unit - a UPS unit where, under normal operation, the output load is powered from the inverter and will therefore continue to operate without a break in the

event of the supply input failing or going outside preset limits.

3.3 Design and construction

3.3.1 (1/7/2022)

UPS units are to be constructed in accordance with IEC 62040-1, IEC 62040-2, IEC 62040-3, IEC 62040-4 and/or IEC 62040-5-3, as applicable, or an acceptable and relevant national or international standard.

3.3.2 (1/7/2006)

The operation of the UPS is not to depend upon external services.

3.3.3 (1/7/2006)

The type of UPS unit employed, whether off-line, line interactive or on-line, is to be appropriate to the power supply requirements of the connected load equipment.

3.3.4 (1/7/2006)

An external bypass is to be provided.

3.3.5 (1/7/2006)

The UPS unit is to be monitored and audible and visual alarm is to be given in a normally attended location for:

- power supply failure (voltage and frequency) to the connected load,
- earth fault,
- operation of a battery protective device,
- when the battery is being discharged, and
- when the bypass is in operation for on-line UPS units.

3.4 Location

3.4.1 (1/1/2023)

The UPS unit providing an alternative power supply or transitional power supply to services as defined in Pt E, Ch 11, Sec 5, [2] and Sec 3, [2.3] and [3.7] is to be suitably located for use in an emergency.

3.4.2 (1/7/2022)

UPS units using valve regulated sealed batteries may be located in compartments with normal electrical equipment, provided the ventilation arrangements are in accordance with the requirements of IEC 62040-1, IEC 62040-2, IEC 62040-3, IEC 62040-4 and/or IEC 62040-5-3, as applicable, or an acceptable and relevant national or international standard.

3.5 Performance

3.5.1 (1/7/2022)

The output power is to be maintained for the duration required for the connected emergency services as stated in SOLAS II-1/42 or SOLAS II-1/43.

3.5.2 (1/7/2006)

No additional circuits are to be connected to the UPS unit without verification that the latter has adequate capacity. The UPS battery capacity is, at all times, to be capable of supplying the designated loads for the time specified in the regulations.

3.5.3 (1/7/2006)

On restoration of the input power, the rating of the charge unit is to be sufficient to recharge the batteries while maintaining the output supply to the load equipment.

3.6 Testing and survey**3.6.1 (1/7/2006)**

UPS units of 50 kVA and over are to be surveyed by the Society during manufacturing and testing.

3.6.2 (1/7/2006)

Appropriate testing is to be carried out to demonstrate that the UPS unit is suitable for its intended environment. This is expected to include, as a minimum, the following tests:

- Functionality, including operation of alarms;
- Temperature rise;
- Ventilation rate;
- Battery capacity.

3.6.3 (1/7/2006)

Where the supply is to be maintained without a break following a power input failure, this is to be verified after installation by means of a practical test.

Table 1 : Tests to be carried out on battery chargers

No.	Tests	Type test (1)	Routine test (2)
1	Examination of the technical documentation, as appropriate, and visual inspection (3) including check of earth continuity	X	X
2	Functional tests (current and voltage regulation, quick, slow, floating charge, alarms)	X	X
3	Temperature rise measurement	X	
4	Insulation test (dielectric strength test and insulation resistance measurement)	X	X

(1) Type test on prototype battery charger or test on at least the first batch of battery chargers.
(2) The certificates of battery chargers routine tested are to contain the manufacturer's serial number of the battery charger which has been type tested and the test result.
(3) A visual examination is to be made of the battery charger to ensure, as far as practicable, that it complies with technical documentation.

4 Fuel cells**4.1 General****4.1.1 (1/1/2023)**

The requirements of this Article apply to fuel cells installed on board.

4.1.2 (1/1/2023)

The use of fuel cells is allowed subject to the compliance of the fuel cell power installation to the requirements given in App 3.

SECTION 8

SWITCHGEAR AND CONTROLGEAR ASSEMBLIES

1 Constructional requirements for main and emergency switchboards

1.1 Construction

1.1.1 (1/1/2021)

Construction is to be in accordance with IEC Publication 60092-302-2.

1.1.2 (1/1/2021)

Switchboard manufactured and tested to standards other than those specified in [1.1.1] will be accepted provided they are in accordance with an acceptable international or national standard of an equivalent or higher safety level.

1.1.3 Where the framework, panels and doors of the enclosure are of steel, suitable measures are to be taken to prevent overheating due to the possible circulation of eddy currents.

1.1.4 Insulating material for panels and other elements of the switchboard is at least to be moisture-resistant and flame-retardant.

1.1.5 Switchboards are to be of dead front type, with enclosure protection according to Sec 3, Tab 2.

1.1.6 Switchboards are to be provided with insulated handrails or handles fitted in an appropriate position at the front of the switchboard. Where access to the rear is necessary for operational or maintenance purposes, an insulated handrail or insulated handles are to be fitted.

1.1.7 Where the aggregate capacity of generators connected to the main busbars exceeds 100 kVA, a separate cubicle for each generator is to be arranged with flame-retardant partitions between the different cubicles. Similar partitions are to be provided between the generator cubicles and outgoing circuits.

1.1.8 Instruments, handles or push-buttons for switchgear operation are to be placed on the front of the switchboard. All other parts which require operation are to be accessible and so placed that the risk of accidental touching of live parts, or accidental making of short-circuits and earthings, is reduced as far as practicable.

1.1.9 Where it is necessary to make provision for the opening of the doors of the switchboard, this is to be in accordance with one of the following requirements:

- a) opening is to necessitate the use of a key or tool (e.g. when it is necessary to replace a lamp or a fuse-link)
- b) all live parts which can be accidentally touched after the door has been opened are to be disconnected before the door can be opened
- c) the switchboard is to include an internal barrier or shutter with a degree of protection not less than IP2X shielding all live parts such that they cannot accidentally be touched when the door is open. It is not to be possible to remove this barrier or shutter except by the use of a key or tool.

1.1.10 All parts of the switchboard are to be readily accessible for maintenance, repair or replacement. In particular, fuses are to be able to be safely inserted and withdrawn from their fuse-bases.

1.1.11 Hinged doors which are to be opened for operation of equipment on the door or inside are to be provided with fixing devices for keeping them in open position.

1.1.12 Means of isolation of the circuit-breakers of generators and other important parts of the installation are to be provided so as to permit safe maintenance while the main busbars are alive.

1.1.13 Where components with voltage exceeding the safety voltage are mounted on hinged doors, the latter are to be electrically connected to the switchboard by means of a separate, flexible protective conductor.

1.1.14 All measuring instruments and all monitoring and control devices are to be clearly identified with indelible labels of durable, flame-retardant material.

1.1.15 The rating of each circuit, together with the rating of the fuse or the appropriate setting of the overload protective device (circuit-breaker, thermal relay etc.) for each circuit is to be permanently indicated at the location of the fuse or protective device.

1.2 Busbars and bare conductors

1.2.1 Busbars are to be of copper or of copper-surrounded aluminium alloy if suitable for use in the marine environment and if precautions are taken to avoid galvanic corrosion.

1.2.2 All connections are to be so made as to inhibit corrosion.

1.2.3 Busbars are to be dimensioned in accordance with IEC Publication 60092-302-2.

The mean temperature rise of busbars is not to exceed 45°C under rated current condition with an ambient air temperature of 45°C (see Sec 2, [1.2.5]) and is not to have any harmful effect on adjacent components. Higher values of temperature rise may be accepted to the satisfaction of the Society.

1.2.4 The cross-section of neutral connection on an a.c. three-phase, four-wire system is to be at least 50% of the cross-section for the corresponding phases.

1.2.5 Bare main busbars, excluding the conductors between the main busbars and the supply side of outgoing units, are to have the minimum clearances and creepage distances given in Tab 1.

The values shown apply to clearances and creepage distances between live parts as well as between live parts and exposed conductive parts.

Table 1 : Clearance and creepage distances

Rated insulation voltage a.c. r.m.s. or d.c. V	Minimum clearance mm	Minimum creepage distance mm
≤ 250	15	20
> 250 to ≤ 690	20	25
> 690	25	35

Note 1: Clearance is the distance between two conductive parts along a string stretched the shortest way between such parts. Creepage distance is the shortest distance along the surface of an insulating material between two conductive parts.

1.2.6 Reduced values as specified in IEC Publication 60092-302-2 may be accepted for type tested and partially type tested assemblies.

The reference values for the evaluation of the minimum clearances and creepage distances for these assemblies are based on the following:

- pollution degree 3 (conductive pollution occurs, or dry non-conductive pollution occurs which becomes conductive due to condensation which is expected)
- overvoltage category III (distribution circuit level)
- inhomogenous field conditions (case A)
- rated operational voltage 1000 V a.c., 1500 V d.c.
- group of insulating material IIIa.

Special consideration is to be given to equipment located in spaces where a pollution degree higher than 3 is applicable, e.g. in diesel engine rooms.

1.2.7 Busbars and other bare conductors with their supports are to be mechanically dimensioned and fixed such that they can withstand the stresses caused by short-circuits.

1.2.8 Busbars and bare conductors are to be protected, where necessary, against falling objects (e.g. tools, fuses or other objects).

1.3 Internal wiring

1.3.1 Insulated conductors for internal wiring of auxiliary circuits of switchboards are to be constructed in accordance with Sec 9, [1.1.5].

1.3.2 All insulated conductors provided for in [1.3.1] are to be of flexible construction and of the stranded type.

1.3.3 Connections from busbars to protective devices are to be as short as possible. They are to be laid and secured in such a way to minimise the risk of a short-circuit.

1.3.4 All conductors are to be secured to prevent vibration and are to be kept away from sharp edges.

1.3.5 Connections leading to indicating and control instruments or apparatus mounted in doors are to be installed such that they cannot be mechanically damaged due to movement of the doors.

1.3.6 Non-metallic trays for internal wiring of switchboards are to be of flame-retardant material.

1.3.7 Control circuits are to be installed and protected such that they cannot be damaged by arcs from the protective devices.

1.3.8 Where foreseen, fixed terminal connectors for connection of the external cables are to be arranged in readily accessible positions.

1.4 Switchgear and controlgear, protective devices

1.4.1 (1/7/2013)

Switchgear and controlgear are to comply with IEC 60947 series adjusted as necessary for the ambient air reference temperature specified in Sec 2, Tab 1 and to be type tested or type approved when required in accordance with Sec 15.

1.4.2 The characteristics of switchgear, controlgear and protective devices for the various consumers are to be in compliance with Sec 3, [7].

1.4.3 (1/7/2015)

For high voltage switchgear and controlgear see Sec 13, [7].

1.4.4 (1/7/2014)

For materials and construction, see Sec 2, [4] and Sec 2, [5].

1.4.5 (1/7/2014)

Power-driven circuit-breakers are to be equipped with an additional separate drive operated by hand.

1.4.6 (1/7/2014)

Power circuit-breakers with a making capacity exceeding 10 kA are to be equipped with a drive which performs the make operation independently of the actuating force and speed.

1.4.7 (1/7/2014)

Where the conditions for closing the circuit-breaker are not satisfied (e.g. if the undervoltage trip is not energised), the closing mechanism is not to cause the closing of the contacts.

1.4.8 (1/7/2014)

All circuit-breakers rated more than 16 A are to be of the trip-free type, i.e. the breaking action initiated by overcurrent or undervoltage releases is to be fulfilled independently of the position of the manual handle or other closing devices.

1.4.9 (1/7/2014)

Short-circuit releases are generally to be independent of energy supplied from circuits other than that to be protected. Tripping due to short-circuit is to be reliable even in the event of a total loss of voltage in the protected circuit.

1.4.10 (1/7/2014)

Short-circuit releases for generators are to be equipped with reclosing inhibitors and are to be delayed for selective tripping.

1.4.11 (1/7/2014)

Overload releases or relays are to operate reliably at any voltage variation of the supply voltage in the protected circuit.

1.4.12 (1/7/2014)

Undervoltage relays or releases are to cause the circuit-breaker to open if the voltage drops to 70%-35% of the rated voltage.

1.4.13 (1/7/2014)

Shunt releases are to ensure the disconnection of the circuit-breaker even when the supply voltage of the release drops to 85% of the rated supply voltage.

1.4.14 (1/7/2014)

The reverse power protection device is to respond to the active power regardless of the power factor, and is to operate only in the event of reverse power.

1.4.15 (1/7/2014)

Single-phase failure devices in three-phase circuits are to operate without a time lag.

1.4.16 (1/7/2014)

Insulation monitoring devices are to continuously monitor the insulation resistance to earth and trigger an alarm should the insulation resistance fall below a predetermined value.

The measuring current of such devices is not to exceed 30 mA in the event of a total short to earth.

1.5 Fuses

1.5.1 (1/7/2015)

Low voltage fuses are to comply with IEC Publication 60269 series and are to be type tested or type approved when required in accordance with Sec 15, [2.1.1].

1.5.2 (1/7/2014)

For high voltage fuses see Sec 13, [7].

1.6 Auxiliary circuits

1.6.1 Auxiliary circuits are to be designed in such a manner that, as far as practicable, faults in such circuits do not impair the safety of the system. In particular, control circuits are to be designed so as to limit the dangers resulting from a fault between the control circuit and earth (e.g. inadvertent operation or malfunction of a component in the installa-

tion), also taking account of the earthing system of their supply.

1.6.2 Auxiliary circuits of essential systems are to be independent of other auxiliary circuits.

1.6.3 Common auxiliary circuits for groups of consumers are permitted only when the failure of one consumer jeopardises the operation of the entire system to which it belongs.

1.6.4 Auxiliary circuits are to be branched off from the main circuit in which the relevant switchgear is used.

1.6.5 The supply of auxiliary circuits by specifically arranged control distribution systems will be specially considered by the Society.

1.6.6 Means are to be provided for isolating the auxiliary circuits as well when the main circuit is isolated (e.g. for maintenance purposes).

1.6.7 For the protection of auxiliary circuits see Sec 3, [7.13].

1.7 Instruments

1.7.1 The upper limit of the scale of every voltmeter is to be not less than 120% of the rated voltage of the circuit in which it is installed.

1.7.2 The upper limit of the scale of every ammeter is to be not less than 130% of the normal rating of the circuit in which it is installed.

1.7.3 The upper limit of the scale of every wattmeter is to be not less than 120% of the rated voltage of the circuit in which it is installed.

1.7.4 Wattmeters for use with a.c. generators which may be operated in parallel are to be capable of indicating 15% reverse power.

1.7.5 For wattmeters using one current circuit only, the measurement of the current of all generators is to be made in the same phase.

1.7.6 The rated value of the measure read, at full load, is to be clearly indicated on the scales of instruments.

1.7.7 Frequency meters are to have a scale at least $\pm 5\%$ of the nominal frequency.

1.7.8 The secondary windings of instrument transformers are to be earthed.

1.7.9 Each a.c. generator not operated in parallel is to be provided with:

- 1 voltmeter
- 1 frequency meter
- 1 ammeter in each phase or 1 ammeter with a selector switch to enable the current in each phase to be read
- 1 three-phase wattmeter in the case of generators rated more than 50 kVA.

1.7.10 Each a.c. generator operated in parallel is to be provided with:

- 1 three-phase wattmeter
- 1 ammeter in each phase or 1 ammeter with a selector switch to enable the current in each phase to be read.

1.7.11 For paralleling purposes the following are to be provided:

- 2 voltmeters
- 2 frequency meters
- 1 synchroscope and synchronising indicating lamps or equivalent means.

A switch is to be provided to enable one voltmeter and one frequency meter to be connected to each generator before the latter is connected to the busbars.

The other voltmeter and frequency meter are to be permanently connected to the busbars.

1.7.12 Each secondary distribution system is to be provided with one voltmeter.

1.7.13 Switchboards are to be fitted with means for monitoring the insulation level of insulated distribution systems as stipulated in Sec 3, [3.2.1].

1.7.14 The main switchboard is to be fitted with a voltmeter or signal lamp indicating that the cable between the shore-connection box and the main switchboard is energised (see Sec 3, [3.8.7]).

1.7.15 For each d.c. power source (e.g. converters, rectifiers and batteries), one voltmeter and one ammeter are to be provided, except for d.c. power sources for starting devices (e.g. starting motor for emergency generator).

2 Constructional requirements for distribution boards

2.1 Construction

2.1.1 (1/1/2021)

Distribution boards are to be constructed, insofar as applicable, as specified for main and emergency switchboards.

2.1.2 All parts which require operation in normal use are to be placed on the front.

2.1.3 Distribution switchboards which are provided with two or more supply circuits arranged for automatic standby connection are to be provided with positive indication of which of the circuits is feeding the switchboard.

3 Testing

3.1 General

3.1.1 Switchboards are to be subjected to the tests specified from [3.2] to [3.4].

3.1.2 The manufacturer is to issue the relative test reports providing information concerning the construction, serial

number and technical data relevant to the switchboard, as well as the results of the tests required.

3.1.3 The tests are to be carried out prior to installation on board.

3.1.4 (1/1/2021)

The test procedures are as specified in IEC Publication 60092-302-2.

3.1.5 (1/1/2021)

The following switchgear and controlgear assemblies are to be surveyed by the Society during testing:

- a) main and emergency switchboards;
- b) low voltage distribution boards, starters and motor control centers having busbars rated current of 100A and above;
- c) steering gear starter;
- d) high voltage assemblies.

3.2 Inspection of equipment, check of wiring and electrical operation test

3.2.1 It is to be verified that the switchboard:

- complies with the approved drawings
- maintains the prescribed degree of protection
- is constructed in accordance with the relevant constructional requirements, in particular as regards creepage and clearance distances.

3.2.2 The connections, especially screwed or bolted connections, are to be checked for adequate contact, possibly by random tests.

3.2.3 Depending on the complexity of the switchboard it may be necessary to carry out an electrical functioning test. The test procedure and the number of tests depend on whether or not the switchboard includes complicated interlocks, sequence control facilities, etc. In some cases it may be necessary to conduct or repeat this test following installation on board.

3.3 High voltage test

3.3.1 The test is to be performed with alternating voltage at a frequency between 25 and 100 Hz of approximately sinusoidal form.

3.3.2 The test voltage is to be applied:

- between all live parts connected together and earth
- between each polarity and all the other polarities connected to earth for the test.

During the high voltage test, measuring instruments, ancillary apparatus and electronic devices may be disconnected and tested separately in accordance with the appropriate requirements.

3.3.3 The test voltage at the moment of application is not to exceed half of the prescribed value. It is then to be increased steadily within a few seconds to its full value. The prescribed test voltage is to be maintained for 1 minute.

3.3.4 The value of the test voltage for main and auxiliary circuits is given in Tab 2 and Tab 3.

Table 2 : Test voltages for main circuits

Rated insulation voltage U_i V	Test voltage c.a (r.m.s.) V
$U_i \leq 60$	1000
$60 < U_i \leq 300$	2000
$300 < U_i \leq 660$	2500
$660 < U_i \leq 800$	3000
$800 < U_i \leq 1000$	3500

Table 3 : Test voltage for auxiliary circuits

Rated insulation voltage U_i V	Test voltage c.a (r.m.s.) V
$U_i \leq 12$	250
$12 < U_i \leq 60$	500
$U_i > 60$	$2 U_i + 1000$ (at least 1500)

3.4 Measurement of insulation resistance

3.4.1 Immediately after the high voltage test, the insulation resistance is to be measured using a device with a direct current voltage of at least 500 V.

3.4.2 The insulation resistance between all current carrying parts and earth (and between each polarity and the other polarities) is to be at least equal to 1 M Ω .

SECTION 9

CABLES

1 Constructional requirements

1.1 Construction

1.1.1 (1/7/2022)

Cables manufactured in accordance with the relevant recommendations of IEC 60092-350, 60092-360, 60092-352, 60092-353, 60092-354, 60092-370 and 60092-376 are acceptable to the Society provided that they are tested as specified in this Chapter.

1.1.2 Mineral-insulated cables are to be constructed according to IEC Publication 60702.

1.1.3 Optical fibre cables are to be constructed in accordance with IEC Publication 60794.

1.1.4 Flexible cables constructed according to national standards will be specially considered by the Society.

1.1.5 (1/7/2017)

Cables manufactured and tested to standards other than those specified in [1.1.1] will be accepted provided they are in accordance with an acceptable and relevant international or national standard of an equivalent or higher safety level.

1.1.6 Insulated wiring for auxiliary circuits of switchboards may be constituted by cables with a single conductor of the stranded type for all sections, PVC- or rubber-insulated in accordance with the Publications cited in [1.1.1] and without further protection.

The insulated wiring is to be at least of the flame-retardant type according to IEC Publication 60332-1. Equivalent types of flame-retardant switchboard wires will be specially considered by the Society.

1.2 Conductors

1.2.1 Conductors are to be of annealed electrolytic copper with a resistivity not exceeding $17,241 \Omega \text{ mm}^2/\text{km}$ at 20°C according to IEC 60228.

1.2.2 Individual conductor wires of rubber-insulated cables are to be tinned or coated with a suitable alloy.

1.2.3 All conductors are to be stranded, except for cables of nominal cross-sectional area $2,5 \text{ mm}^2$ and less (provided that adequate flexibility of the finished cable is assured).

1.2.4 For the minimum nominal cross-sectional areas permitted, see Sec 3, [9.10].

1.3 Insulating materials

1.3.1 The materials used for insulation are to comply with IEC Publication 60092-360 and to have the thicknesses

specified for each type of cable in the relevant standard. The maximum permissible rated temperature is specified for the various materials.

1.3.2 Materials and thicknesses other than those in [1.3.1] will be specially considered by the Society.

1.4 Inner covering, fillers and binders

1.4.1 The cores of a multicore cable are to be laid up. The spaces between the cores are to be filled so as to obtain an assembly having an essentially circular cross-section. The filling may be omitted in multicore cables having a conductor cross-sectional area not exceeding 4 mm^2 .

When a non-metallic sheath is applied directly over the inner covering or the fillers, it may substitute partially for the inner covering or fillers.

1.4.2 The materials used, the binders and the thicknesses of the inner coverings are generally to be in accordance with IEC Publications of the series 60092-3..., in relation to the type of cable.

1.5 Protective coverings (armour and sheath)

1.5.1 Metallic armour, if not otherwise protected against corrosion, is to be protected by means of a coating of protective paint (see Sec 3, [9.3]).

1.5.2 The paint is to be non-flammable and of adequate viscosity. When dry, it is not to flake off.

1.5.3 The materials and construction used for (metal) armour are to be in accordance with IEC Publication 60092-350 and their dimensions are to be those specified for each type of cable in the relevant standard.

1.5.4 The materials used for sheaths are to be in accordance with IEC Publication 60092-360 and are to have the thicknesses specified for each type of cable in the relevant standard.

The quality of the materials is to be adequate to the service temperature of the cable.

1.5.5 Materials other than those in [1.5.3] and [1.5.4] will be specially considered by the Society.

1.6 Identification

1.6.1 Each cable is to have clear means of identification so that the manufacturer can be determined.

1.6.2 Fire non propagating cables are to be clearly labelled with indication of the standard according to which

this characteristic has been verified and, if applicable, of the category to which they correspond.

1.6.3 (1/7/2003)

Fire-resisting cables are to be clearly labelled with the indication of the standard according to which this characteristic has been verified.

2 Testing

2.1 Type tests

2.1.1 Type tests are to be in accordance with the relevant IEC 60092-3.. Series Publications and IEC 60332-1, IEC 60332-3 Category A, and IEC 60331 where applicable.

2.2 Routine tests

2.2.1 Every length of finished cable is to be subjected to the tests specified in [2.2.2].

2.2.2 The following routine tests are to be carried out:

- a) visual inspection
- b) check of conductor cross-sectional area by measuring electrical resistance

- c) high voltage test
- d) insulation resistance measurement
- e) dimensional checks (as necessary).

2.2.3 The manufacturer is to issue a statement providing information on the type and characteristics of the cable, as well as the results of the tests required and the Type Approval Certificates.

2.2.4 The test procedure is as specified in IEC Publication 60092-350.

2.2.5 (29/8/2003)

Power cables for electrical propulsion systems, other than internal wiring in switchboards, are to be type approved and tested for acceptance in the presence of the Surveyor. Acceptance tests are to include at least:

- a) a high voltage test
- b) insulation resistance measurement.

2.2.6 Where an alternative scheme, e.g. a certified quality assurance system, is recognised by the Society, attendance of the Surveyor may not be required.

SECTION 10

MISCELLANEOUS EQUIPMENT

1 Lighting fittings

1.1 Applicable requirements

1.1.1 Lighting fittings are to comply with IEC Publications 60598 and 60092-306.

Lighting fittings complying with other standards will be specially considered by the Society.

1.2 Construction

1.2.1 The temperature of terminals for connection of supplying cables is not to exceed the maximum conductor temperature permitted for the cable (see Sec 3, [9.9]).

Where necessary, luminaires are to be fitted with terminal boxes which are thermally insulated from the light source.

1.2.2 Wires used for internal connections are to be of a temperature class which corresponds to the maximum temperature within the luminaire.

1.2.3 The temperature rise of parts of luminaires which are in contact with the support is not to exceed 50°C. The rise is not to exceed 40°C for parts in contact with flammable materials.

1.2.4 The temperature rise of surface parts which can easily be touched in service is not to exceed 15°C.

1.2.5 High-power lights with higher surface temperatures than those in [1.2.2] and [1.2.3] are to be adequately protected against accidental contact.

2 Accessories

2.1 Applicable requirements

2.1.1 Accessories are to be constructed in accordance with the relevant IEC Publications, and in particular with Publication 60092-306.

2.2 Construction

2.2.1 Enclosures of accessories are to be of metal having characteristics suitable for the intended use on board, or of flame-retardant insulating material.

2.2.2 Terminals are to be suitable for the connection of stranded conductors, except in the case of rigid conductors for mineral-insulated cables.

3 Plug-and-socket connections

3.1 Applicable requirements

3.1.1 (1/1/2022)

Plug-and-socket connections are to comply with IEC Publication 60092-306 and with the following additional standards in relation to their use:

- in accommodation spaces, day rooms and service rooms (up to 16 A, 250 V a.c.): IEC Publication 60083 or 60320, as applicable
- for power circuits (up to 250 A, 690 V a.c.): IEC Publication 60309
- for electronic switchgear: IEC Publications, e.g. 60130 and 60603
- for refrigerated containers: ISO 1496-2
- for high voltage shore connections: IEC Publications 62613-1 (see Pt F, Ch 13, Sec 15).

4 Heating and cooking appliances

4.1 Applicable requirements

4.1.1 Heating and cooking appliances are to comply with the relevant IEC Publications (e.g. those of series 60335), with particular attention to IEC 60092-307.

4.2 General

4.2.1 Heating elements are to be enclosed and protected with metal or refractory material.

4.2.2 The terminals of the power supply cable are not to be subjected to a higher temperature than that permitted for the conductor of the connection cable.

4.2.3 The temperature of parts which are to be handled in service (switch knobs, operating handles and the like) is not to exceed the following values:

- 55°C for metal parts
- 65°C for vitreous or moulded material.

4.3 Space heaters

4.3.1 The casing or enclosure of heaters is to be so designed that clothing or other flammable material cannot be placed on them.

4.3.2 The temperature of the external surface of space heaters is not to exceed 60°C.

4.3.3 Space heaters are to be provided with a temperature limiting device without automatic reconnection which automatically trips all poles or phases not connected to

earth when the temperature exceeds the maximum permissible value.

4.4 Cooking appliances

4.4.1 Live parts of cooking appliances are to be protected such that any foods or liquids which boil over or spill do not cause short-circuits or loss of insulation.

4.5 Fuel oil and lube oil heaters

4.5.1 In continuous-flow fuel oil and lube oil heaters, the maximum temperature of the heating elements is to be below the boiling point of the oil.

4.5.2 Each oil heater is to be provided with a thermostat maintaining the oil temperature at the correct level.

4.5.3 In addition to the thermostat in [4.5.2], each oil heater is to be provided with a temperature limiting device without automatic reconnection, and with the sensing device installed as close as possible to the heating elements and permanently submerged in the liquid.

4.6 Water heaters

4.6.1 Water heaters are to be provided with a thermostat and safety temperature limiter.

5 Cable trays/protective casings made of plastics materials

5.1 General requirement

5.1.1 (1/7/2023)

Cable trays/protective casings (see Note 1) made of plastic (see Note 2) materials are to be type tested or type approved (See Note 3).

Note 1: "Protective casing" means a closed cover in the form of a pipe or other closed ducts of non-circular shape.

Note 2: "Plastics" means both thermoplastic and thermosetting plastic materials with or without reinforcement, such as PVC and fibre reinforced plastics - FRP.

Note 3: "Cable trays/protective casings made of plastic materials" are to be type tested or type approved in accordance with the latest published version of IACS REC 73.

5.2 Installation Requirements

5.2.1 (1/7/2003)

Cable trays/protective casings made of plastics materials are to be supplemented by metallic fixing and straps such that in the event of a fire they, and the cables affixed, are prevented from falling and causing an injury to personnel and/or an obstruction to any escape route.

Note 1: When plastic cable trays/protective casings are used on open deck, they are additionally to be protected against UV light.

5.2.2 (1/7/2003)

The load on the cable trays/protective casings is to be within the Safe Working Load (SWL). The support spacing is to be not greater than the Manufacturer's recommendation or in excess of the spacing at the SWL test. In general it is not to exceed 2 metres.

The selection and spacing of cable tray/protective casing supports are to take into account:

- dimensions of cable trays/protective casings;
- mechanical and physical properties of their material;
- mass of cable trays/protective casings;
- loads due to weight of cables, external forces, thrust forces and vibrations;
- maximum accelerations to which the system may be subjected;
- combination of loads.

5.2.3 (1/7/2003)

The sum of the cables' total cross-sectional area, based on the cables' external diameter, is not to exceed 40% of the protective casing's internal cross-sectional area. This does not apply to a single cable in a protective casing.

SECTION 11

LOCATION

1 General

1.1 Location

1.1.1 The degree of protection of the enclosures and the environmental categories of the equipment are to be appropriate to the spaces or areas in which they are located; see Sec 3, Tab 2, Sec 3, Tab 3 and Sec 2, [5.2.2].

1.2 Areas with a risk of explosion

1.2.1 Except where the installation of equipment for explosive gas atmosphere is provided for by the Rules, electrical equipment is not to be installed where flammable gases or vapours are liable to accumulate; see Sec 3, [10].

2 Main electrical system

2.1 Location in relation to the emergency system

2.1.1 The arrangement of the emergency electrical system is to be such that a fire or other casualty in spaces containing the emergency source of electrical power, associated converting equipment, if any, the emergency switchboard and the emergency lighting switchboard will not render inoperative the main electric lighting system and the other primary essential services.

2.2 Main switchboard

2.2.1 *The main switchboard shall be so placed relative to one main generating station that, as far as is practicable, the integrity of the normal electrical supply may be affected only by a fire or other casualty in one space.*

2.2.2 *An environmental enclosure for the main switchboard, such as may be provided by a machinery control room situated within the main boundaries of the space, is not to be considered as separating switchboards from generators.*

2.2.3 The main generating station is to be situated within the machinery space, i.e. within the extreme main transverse watertight bulkheads.

2.2.4 Any bulkhead between the extreme main transverse watertight bulkheads is not regarded as separating the equipment in the main generating station provided that there is access between the spaces.

2.2.5 The main switchboard is to be located as close as practicable to the main generating station, within the same machinery space and the same vertical and horizontal A60 fire boundaries.

2.2.6 (1/1/2021)

Where essential services for steering and propulsion are supplied from distribution boards, these and any transformers, converters and similar appliances constituting an essential part of the electrical supply system are also to satisfy the above provisions.

2.2.7 A non-required subdivision bulkhead, with sufficient access, located between the switchboard and generators, or between two or more generators, is not to be considered as separating the equipment.

3 Emergency electrical system

3.1 Spaces for the emergency source

3.1.1 *The emergency source of electrical power, associated transforming equipment, if any, transitional source of emergency power, emergency switchboard and emergency lighting switchboard shall be located above the uppermost continuous deck and shall be readily accessible from the open deck.*

They shall not be located forward of the collision bulkhead.

3.1.2 *The spaces containing the emergency source of electrical power, associated transforming equipment, if any, the transitional source of emergency electrical power and the emergency switchboard are not to be contiguous to the boundaries of machinery spaces of Category A or those spaces containing the main source of electrical power, associated transforming equipment, if any, and the main switchboard.*

Where this is not practicable, the contiguous boundaries are to be Class A60.

3.2 Location in relation to the main electrical system

3.2.1 *The location of the emergency source of electrical power, associated transforming equipment, if any, the transitional source of emergency power, the emergency switchboard and the emergency lighting switchboard in relation to the main source of electrical power, associated transforming equipment, if any, and the main switchboard shall be such as to ensure to the satisfaction of the Society that a fire or other casualty in the space containing the main source of electrical power, associated transforming equipment, if any, and the main switchboard or in any machinery space of Category A will not interfere with the supply, control and distribution of emergency electrical power.*

3.2.2 The arrangement of the main electrical system is to be such that a fire or other casualty in spaces containing the main source of electrical power, associated converting equipment, if any, the main switchboard and the main light-

ing switchboard will not render inoperative the emergency electric lighting system and the other emergency services other than those located within the spaces where the fire or casualty has occurred.

3.3 Emergency switchboard

3.3.1 *The emergency switchboard shall be installed as near as is practicable to the emergency source of electrical power.*

3.3.2 *Where the emergency source of electrical power is a generator, the emergency switchboard shall be located in the same space unless the operation of the emergency switchboard would thereby be impaired.*

3.4 Emergency battery

3.4.1 *No accumulator battery fitted in accordance with the provisions of Sec 3, [2.3] shall be installed in the same space as the emergency switchboard.*

3.4.2 (1/1/2021)

For ships not subject to SOLAS, accumulator batteries fitted in accordance with the provisions of Sec 3, [2.3] may be accepted in the same space as the emergency switchboard, provided that they are not vented type batteries connected to a charging device of power greater than 2 kW.

4 Distribution boards

4.1 Distribution boards for cargo spaces and similar spaces

4.1.1 Distribution boards containing multipole switches for the control of power and lighting circuits in bunkers and cargo spaces are to be situated outside such spaces.

4.2 Distribution board for navigation lights

4.2.1 The distribution board for navigation lights is to be placed in an accessible position on the bridge.

5 Cable runs

5.1 General

5.1.1 Cable runs are to be selected so as to be as far as practicable accessible, with the exception of single cables, situated behind walls or ceilings constructed of incombustible materials, supplying lighting fittings and socket-outlets in accommodation spaces, or cables enclosed in pipes or conduits for installation purposes.

5.1.2 Cable runs are to be selected so as to avoid action from condensed moisture and from dripping of liquids.

5.1.3 Connection and draw boxes are to be accessible.

5.1.4 Cables are generally not to be installed across expansion joints.

Where this is unavoidable, however, a loop of cable of length proportional to the expansion of the joint is to be provided (see Sec 12, [7.2.2]).

5.2 Location of cables in relation to the risk of fire and overheating

5.2.1 Cables and wiring serving essential or emergency power, lighting, internal communications or signals are, so far as is practicable, to be routed clear of galleys, laundries, machinery spaces of Category A and their casings and other high fire risk areas, except for supplying equipment in those spaces.

5.2.2 When it is essential that a circuit functions for some time during a fire and it is unavoidable to carry the cable for such a circuit through a high fire risk area (e.g. cables connecting fire pumps to the emergency switchboard), the cable is to be of a fire-resistant type or adequately protected against direct exposure to fire.

5.2.3 (1/1/2021)

Main cable runs (see Note 1) and cables for the supply and control of essential services are, as far as is practicable, to be kept away from machinery parts having an increased fire risk (see Note 2) unless:

- the cables have to be connected to the subject equipment,
- the cables are protected by a steel bulkhead or deck, or
- the cables in that area are of the fire-resisting type.

Note 1: Main cable runs are for example:

- cable runs from generators and propulsion motors to main and emergency switchboards
- cable runs directly above or below main and emergency switchboards, centralised motor starter panels, distribution boards and centralised control panels for propulsion and essential auxiliaries.

Note 2: Machinery, machinery parts or equipment handling combustibles are considered to present an increased fire risk.

5.2.4 Cables and wiring serving essential or emergency power, lighting, internal communications or signals are to be arranged, as far as practicable, in such a manner as to preclude their being rendered unserviceable by heating of the bulkheads that may be caused by a fire in an adjacent space.

5.2.5 Cables are to be arranged as remote as possible from sources of heat such as hot pipes, resistors, etc. Where installation of cables near heat sources cannot be avoided, and where there is consequently a risk of damage to the cables by heat, suitable shields are to be installed, or other precautions to avoid overheating are to be taken, for example use of ventilation, heat insulation materials or special heat-resisting cables.

5.3 Location of cables in relation to electromagnetic interference

5.3.1 For the installation of cables in the vicinity of radio equipment or of cables belonging to electronic control and monitoring systems, steps are to be taken in order to limit the effects of unwanted electromagnetic interference (see Ch 3, Sec 7).

5.4 Services with a duplicate feeder

5.4.1 In the case of essential services requiring a duplicate supply (e.g. steering gear circuits), the supply and associated control cables are to follow different routes which are to be as far apart as practicable, separated both vertically and horizontally.

5.5 Emergency circuits

5.5.1 Cables supplying emergency circuits are not to run through spaces containing the main source of electrical power, associated transforming equipment, if any, the main switchboard and the main lighting switchboard, except for cables supplying emergency equipment located within such spaces (see [3.2.2]).

5.6 Electrical distribution in passenger ships

5.6.1 For the electrical distribution in passenger ships, see Pt E, Ch 11, Sec 5, [1.3].

6 Storage batteries

6.1 General

6.1.1 Batteries are to be located where they are not exposed to excessive heat, extreme cold, spray, steam or other conditions which would impair performance or accelerate deterioration. They are to be installed in such a way that no damage may be caused to surrounding appliances by the vapours generated.

6.1.2 Storage batteries are to be suitably housed, and compartments (rooms, lockers or boxes) used primarily for their accommodation are to be properly constructed and efficiently ventilated so as to prevent accumulation of flammable gas.

6.1.3 Starter batteries are to be located as close as practicable to the engine or engines served.

6.1.4 *Accumulator batteries shall not be located in sleeping quarters except where hermetically sealed to the satisfaction of the Society.*

6.1.5 Lead-acid batteries and alkaline batteries are not to be installed in the same compartment (room, locker, box), unless of valve-regulated sealed type.

6.2 Large vented batteries

6.2.1 Batteries connected to a charging device of power exceeding 2 kW, calculated from the maximum obtainable charging current and the nominal voltage of the battery (hereafter referred to as "large batteries") are to be installed in a room assigned to batteries only.

Where this is not possible, they may be arranged in a suitable locker on deck.

6.2.2 Rooms assigned to large batteries are to be provided with mechanical exhaust ventilation.

Natural ventilation may be employed for boxes located on open deck.

6.2.3 The provisions of [6.2.1] and [6.2.2] also apply to several batteries connected to charging devices of total power exceeding 2 kW calculated for each one as stated in [6.2.1].

6.3 Moderate vented batteries

6.3.1 Batteries connected to a charging device of power between 0,2 kW and 2 kW calculated as stated in [6.2.1] (hereafter referred to as "moderate batteries") are to be arranged in the same manner as large batteries or placed in a box or locker in suitable locations such as machinery spaces, storerooms or similar spaces. In machinery spaces and similar well-ventilated compartments, these batteries may be installed without a box or locker provided they are protected from falling objects, dripping water and condensation where necessary.

6.3.2 Rooms, lockers or boxes assigned to moderate batteries are to be provided with natural ventilation or mechanical exhaust ventilation, except for batteries installed without a box or locker (located open) in well-ventilated spaces.

6.3.3 The provisions of [6.3.1] and [6.3.2] also apply to several batteries connected to charging devices of total power between 0,2 kW and 2 kW calculated for each one as stated in [6.2.1].

6.4 Small vented batteries

6.4.1 Batteries connected to a charging device of power less than 0,2 kW calculated as stated in [6.2.1] (hereafter referred to as "small batteries") are to be arranged in the same manner as moderate or large batteries, or without a box or locker, provided they are protected from falling objects, or in a box in a ventilated area.

6.4.2 Boxes for small batteries may be ventilated only by means of openings near the top to permit escape of gas.

6.5 Ventilation

6.5.1 The ventilation of battery compartments is to be independent of ventilation systems for other spaces.

6.5.2 The quantity of air expelled (by natural or forced ventilation) for compartments containing vented type batteries is to be at least equal to:

$$Q = 110 \cdot I \cdot n$$

where:

- Q : Quantity of air expelled, in litres per hour
I : Maximum current delivered by the charging equipment during gas formation, but not less than one quarter of the maximum obtainable charging current in amperes
n : Number of cells in series.

6.5.3 The quantity of air expelled (by natural or forced ventilation) for compartments containing valve-regulated sealed batteries is to be at least 25% of that given in [6.5.2].

6.5.4 Ducts are to be made of a corrosion-resisting material or their interior surfaces are to be painted with corrosion-resistant paint.

6.5.5 Adequate air inlets (whether connected to ducts or not) are to be provided near the floor of battery rooms or the bottom of lockers or boxes (except for that of small batteries).

Air inlet may be from the open air or from another space (for example from machinery spaces).

6.5.6 Exhaust ducts of natural ventilation systems:

- a) are to be run directly from the top of the compartment to the open air above (they may terminate in the open or in well-ventilated spaces)
- b) are to terminate not less than 90 cm above the top of the battery compartment
- c) are to have no part more than 45° from the vertical
- d) are not to contain appliances (for example for barring flames) which may impede the free passage of air or gas mixtures.

Where natural ventilation is impracticable or insufficient, mechanical exhaust ventilation is to be provided.

6.5.7 In mechanical exhaust ventilation systems:

- a) electric motors are to be outside the exhaust ducts and battery compartment and are to be of safe type if installed within 3 m from the exhaust of the ventilation duct
- b) fans are to be so constructed and of a material such as to render sparking impossible in the event of the impeller touching the fan casing
- c) steel or aluminium impellers are not to be used
- d) the system is to be interlocked with the charging device so that the battery cannot be charged without ventilation (trickle charge may be maintained)
- e) a temperature sensor is to be located in the battery compartment to monitor the correct behaviour of the battery in cases where the battery element is sensitive to temperature.

6.5.8 For natural ventilation systems for deck boxes:

- a) holes for air inlet are to be provided on at least two opposite sides of the box
- b) the exhaust duct is to be of ample dimensions
- c) the duct is to terminate at least 1,25 m above the box in a goose-neck or mushroom-head or the equivalent
- d) the degree of protection is to be in accordance with Sec 3, Tab 2.

SECTION 12 INSTALLATION

1 General

1.1 Protection against injury or damage caused by electrical equipment

1.1.1 All electrical equipment is to be so installed as not to cause injury when handled or touched in the normal manner.

1.1.2 All electrical equipment is to be installed in such a way that live parts cannot be inadvertently touched, unless supplied at a safety voltage.

1.1.3 For protective earthing as a precaution against indirect contact, see [2].

1.1.4 Equipment is to be installed so as not to cause, or at least so as to reduce to a minimum, electromagnetic interference.

1.2 Protection against damage to electrical equipment

1.2.1 Electrical equipment is to be so placed that as far as practicable it is not exposed to risk of damage from water, steam, oil or oil vapours.

1.2.2 The air supply for internal ventilation of electrical equipment is to be as clean and dry as practicable; cooling air for internal ventilation is not to be drawn from below the floor plates in engine and/or boiler rooms.

1.2.3 Equipment is to be so mounted that its enclosing arrangements and the functioning of the built-in equipment will not be affected by distortions, vibrations and movements of the ship's structure or by other damage liable to occur.

1.2.4 If electrical fittings, not of aluminium, are attached to aluminium, suitable provision is to be made to prevent galvanic corrosion.

1.3 Accessibility

1.3.1 Equipment is to be so installed that sufficient space is available for inspection and maintenance as required for all its parts (see [6.1.3]).

2 Earthing of non-current carrying parts

2.1 Parts which are to be earthed

2.1.1 Exposed metal parts of both fixed and portable electrical machines or equipment which are not intended to

be live but which are liable under fault conditions to become live and similar metal parts inside non-metallic enclosures are to be earthed unless the machines or equipment are:

- a) supplied at a voltage not exceeding 50 V direct current or 50 V, root mean square between conductors, achieved without the use of auto-transformers (safety voltage); or
- b) supplied at a voltage not exceeding 250 V by safety isolating transformers supplying one consuming device only; or
- c) constructed in accordance with the principle of double insulation.

2.1.2 To minimise shock from high frequency voltage induced by the radio transmitter, handles, handrails and other metal elements on the bridge or upper decks are to be in electrical connection with the hull or superstructures.

2.2 Methods of earthing

2.2.1 Metal frames or enclosures of apparatus and electrical machinery may be fixed to, and in metallic contact with, the ship's structure, provided that the surfaces in contact are clean and free from rust, scale or paint when installed and are firmly bolted together.

2.2.2 For metal frames or enclosures which are not earthed as specified in [2.2.1], earthing connections complying with [2.3] and [2.4] are to be used.

2.2.3 For requirements regarding the earthing of coverings of cables and the mechanical protection of cables, see [7.11] and [7.12].

2.3 Earthing connections

2.3.1 Every earthing connection is to be of copper or other corrosion-resistant material and is to be securely installed and protected, where necessary, against damage and electrolytic corrosion.

2.3.2 The nominal cross-sectional area of each copper earthing connection is to be not less than that required in Tab 1.

Earthing connections of other metals are to have conductance at least equal to that specified for a copper earthing connection.

Table 1 : Cross-sectional area of earth-continuity conductors and earthing connections

Type of earthing connection		Cross-sectional area of associated current carrying conductor	Minimum cross-sectional area of copper earthing connection	
1	Earth-continuity conductor in flexible cable or flexible cord	any	Same as current carrying conductor up to and including 16 mm ² and one half above 16 mm ² but at least 16 mm ²	
2	Earth-continuity conductor incorporated in fixed cable	any	a) for cables having an insulated earth-continuity conductor <ul style="list-style-type: none"> a cross-section equal to the main conductors up to and including 16 mm², but minimum 1,5 mm² a cross-section not less than 50% of the cross-section of the main conductor when the latter is more than 16 mm², but at least 16 mm² 	
			b) for cables with a bare earth wire in direct contact with the lead sheath	
			Cross-section of main conductor mm ²	Earthing connection mm ²
			1 ÷ 2,5	1
			4 ÷ 6	1,5
3	Separate fixed earthing conductor	≤ 2,5 mm ²	Same as current carrying conductor subject to minimum of 1,5 mm ² for stranded earthing connection or 2,5 mm ² for unstranded earthing connection	
		> 2,5 mm ² but ≤ 120 mm ²	One half the cross-sectional area of the current carrying conductor, subjected to a minimum of 4 mm ²	
		> 120 mm ²	70 mm ²	

2.3.3 Metal parts of portable appliances are to be earthed, where required (see [2.1.1]), by means of an earth-continuity conductor in the flexible supply cable or cord, which has the cross-sectional area specified in Tab 1 and which is earthed, for example, through the associated plug and socket.

2.3.4 In no circumstances is the lead sheathing or armour of cables to be relied upon as the sole means of earthing.

2.4 Connection to the ship's structure

2.4.1 Every connection of an earth-continuity conductor or earthing lead to the ship's structure is to be secured by means of a screw of brass or other corrosion-resistant material of diameter not less than 6 mm.

2.4.2 Such earthing connection is not to be used for other purposes.

2.4.3 The connection described in [2.4.1] is to be located in an accessible position where it may readily be checked.

2.5 Earthed distribution systems

2.5.1 The system earthing of earthed distribution systems is to be effected by means independent of any earthing arrangements of non-current carrying parts and is to be connected to the hull at one point only.

2.5.2 In an earthed distribution system in which the earthing connection does not normally carry current, this connection is to conform with the requirements of [2.3],

except that the lower limit of 70 mm² (see Tab 1) does not apply.

2.5.3 In a distribution system with hull return, the system earthing connection is to have at least the same cross-sectional area as the feeder lines.

2.5.4 The earthing connection is to be in an accessible position where it may readily be inspected and disconnected for insulation testing.

2.6 Aluminium superstructures

2.6.1 When aluminium superstructures are insulated from the steel hull to prevent electrolytic corrosion, they are to be secured to the hull by means of a separate bonding connection.

2.6.2 The connections are to be adequately close together and are to have a resistance less than 0.1 Ω.

2.6.3 The connections are to be located where they may readily be inspected.

3 Rotating machines

3.1

3.1.1 Every rotating machine is preferably to be installed with the shaft in the fore-and-aft direction. Where a rotating machine of 100 kW and over is installed athwartship, or vertically, it is to be ensured that the design of the bearings

and the arrangements for lubrication are satisfactory to withstand the rolling specified in Sec 2, Tab 4.

4 Semiconductor convertors

4.1 Semiconductor power convertors

4.1.1 Naturally air-cooled semiconductor convertors are to be installed such that the circulation of air to and from the stacks or enclosures is not impeded and that the temperature of the cooling inlet air to convertor stacks does not exceed the ambient temperature for which the stacks are specified.

5 Vented type storage batteries

5.1 General

5.1.1 Batteries are to be arranged so that each cell or crate of cells is accessible from the top and at least one side to permit replacement and periodical maintenance.

5.1.2 Cells or crates are to be carried on insulating supports of material non-absorbent to the electrolyte (e.g. treated wood).

5.1.3 Cells are to be securely chocked by means of insulating material non-absorbent to the electrolyte, e.g. strips of treated wood. Special mechanical precautions are to be taken to prevent the emergency battery from being damaged by the shock due to a collision.

5.1.4 Provision is to be made for the free circulation of air.

5.2 Protection against corrosion

5.2.1 The interior of battery compartments (rooms, lockers, boxes) including all metal parts subject to the electrolyte is to be protected against the deteriorating effect of the latter by electrolyte-resistant coating or other equivalent means, unless corrosion-resistant materials are used.

5.2.2 Interior surfaces of metal shelves for battery cells, whether or not grouped in crates or trays, are to be protected by a lining of electrolyte-resistant material, watertight and carried up to at least 75 mm on all sides. In particular, linings are to have a minimum thickness of 1,5 mm, if of lead sheet for lead-acid batteries, and of 0,8 mm, if of steel for alkaline batteries.

Alternatively, the floor of the room or locker is to be lined as specified above to a height of at least 150 mm.

5.2.3 Battery boxes are to be lined in accordance with [5.2.2] to a height of at least 75 mm.

6 Switchgear and controlgear assemblies

6.1 Main switchboard

6.1.1 The main switchboard is to be so arranged as to give easy access as may be needed to apparatus and equipment, without danger to personnel.

6.1.2 An unobstructed space is to be left in front of the switchboard wide enough to allow access for operation; such width is generally about 1 metre.

When withdrawable equipment is contained in the switchboard, the width of the space is to be not less than 0,5 m when the equipment is fully withdrawn.

Reduced widths may be considered for small ships.

6.1.3 Where necessary, an unobstructed space is to be provided at the rear of the switchboard ample to permit maintenance; in general, the width of this passage is to be not less than 0,6 m, except that this may be reduced to 0,5 m in way of stiffeners and frames, and the height sufficient for the operation foreseen.

6.1.4 Where the switchboard is open at the rear, the rear space in [6.1.3] is to form a locked space provided at each end with an access door. The required IP protection for the corresponding location is to be fulfilled.

6.1.5 If necessary, the clear height above the switchboard specified by the manufacturer is to be maintained for pressure relief in the event of a short-circuit.

6.1.6 When the voltage exceeds the safety voltage, non-conducting mats or gratings are to be provided at the front and rear of the switchboard as necessary.

6.1.7 Piping and conduits are not to be installed directly above or in the vicinity of switchboards and controlgear assemblies.

Where this is unavoidable, pipes and conduits are to have welded joints only or to be provided with protection against spray from steam or pressurised liquids or dripping.

6.2 Emergency switchboard

6.2.1 For the installation of the emergency switchboard, the same requirements apply as given in [6.1] for the installation of the main switchboard.

6.3 Distribution boards

6.3.1 (1/1/2021)

For the installation of distribution boards, the same requirements apply, as far as applicable, as given in [6.1] for the installation of the main switchboard.

7 Cables

7.1 General

7.1.1 Cables having insulating materials with different maximum permissible conductor temperatures are not to be bunched together.

Where this is not practicable, the cables are to be so installed that no cable reaches a temperature higher than its rating.

7.1.2 Cables having a protective covering which may damage the covering of more vulnerable cables are not to be bunched with the latter.

7.1.3 Cables having a bare metallic sheath (e.g. of copper) or braid or armour are to be installed in such a way that galvanic corrosion by contact with other metals is prevented.

7.1.4 All cables and wiring external to equipment are to be so installed as not to impair their original flame-retarding properties.

To this end, the following methods may be used:

- a) the use of cables which have been tested in accordance with IEC Publication 332-3 Category A or an equivalent test procedure for cables installed in bunches, or
- b) the use of fire stops having at least B0 penetrations fitted as follows (see Fig 1, Fig 2, Fig 3 and Fig 4):
 - cable entries at the main and emergency switchboard
 - where cables enter engine control rooms
 - cable entries at centralised control panels for propulsion machinery and essential auxiliaries
 - at each end of totally enclosed cable trunks
 - at every second deck or approximately 6 metres for verticals runs and every 14 metres for horizontal runs in enclosed and semi-enclosed spaces
 - at the boundaries of the spaces in cargo areas.
- c) the use of fire protection coating applied to at least 1 metre in every 14 metres on horizontal cable runs and over the entire length of vertical cable runs for cables installed in enclosed and semi-enclosed spaces.

The cable penetrations are to be installed in steel plates of at least 3 mm thickness extending all around to twice the

largest dimension of the cable run for vertical runs and once for horizontal runs, but need not extend through ceilings, decks, bulkheads or solid sides of trunks. These precautions apply in particular to bunches of 5 or more cables in areas with a high fire risk (such as Category A machinery spaces, galleys etc.) and to bunches of more than 10 cables in other areas.

7.2 Radius of bend

7.2.1 The internal radius of bend for the installation of cables is to be chosen according to the type of cable as recommended by the manufacturer.

Its value is generally to be not less than the figure given in Tab 2.

7.2.2 Where the installation of cables across expansion joints is unavoidable, the minimum internal radius of the loop at the end of the travel of the expansion joint is to be not less than 12 times the external diameter of the cable.

Figure 1 : Totally enclosed trunks

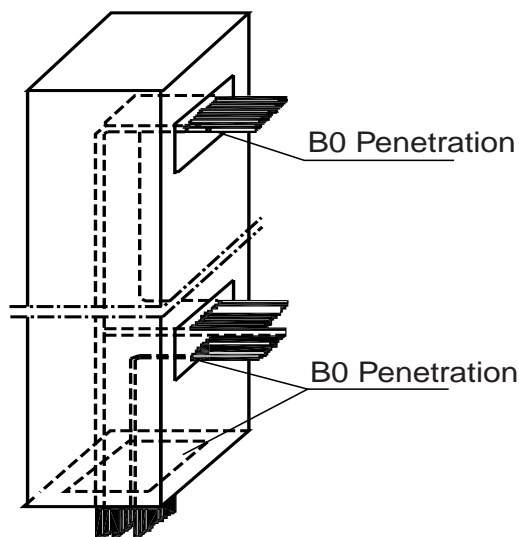

Table 2 : Bending radii

Cable construction		Overall diameter of cable (D)	Minimum internal radius of bend
Insulation	Outer covering		
Thermoplastic or thermosetting with circular copper conductors	Unarmoured or unbraided	≤ 25 mm	4 D
		> 25 mm	6 D
	Metal braid screened or armoured	Any	6 D
	Metal wire armoured	Any	6 D
	Metal tape armoured or metal-sheathed	Any	6 D
Thermoplastic or thermosetting with shaped copper conductors	Composite polyester/metal laminate tape screened units or collective tape screening	Any	8 D
		Any	8 D

Figure 2 : Non-totally enclosed trunks, vertical

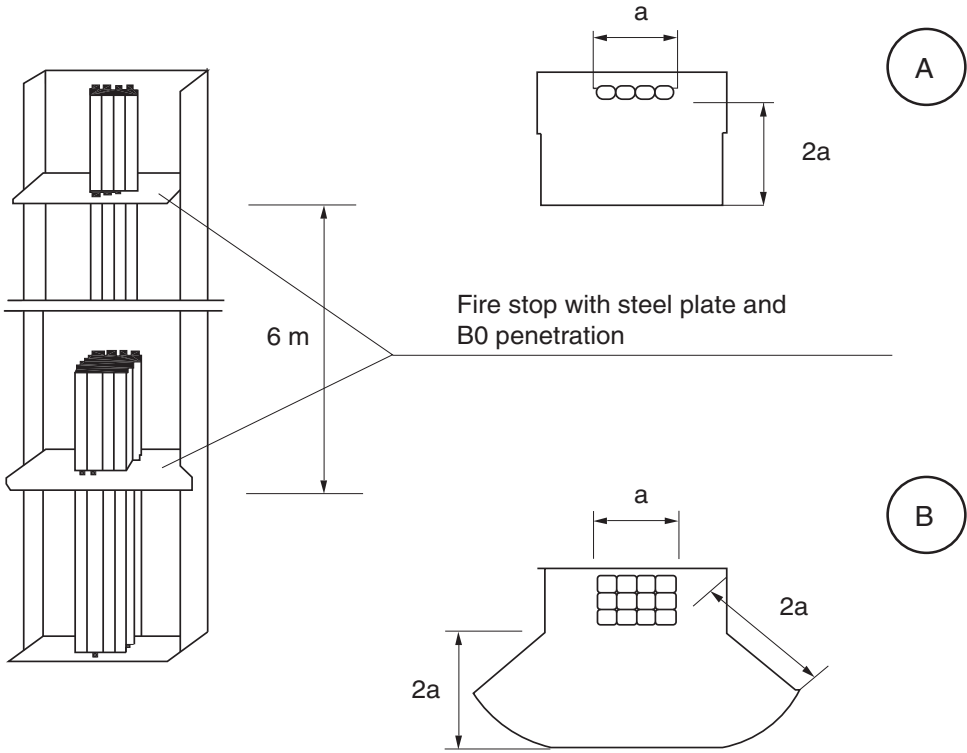

Figure 3 : Non-totally enclosed trunks, horizontal

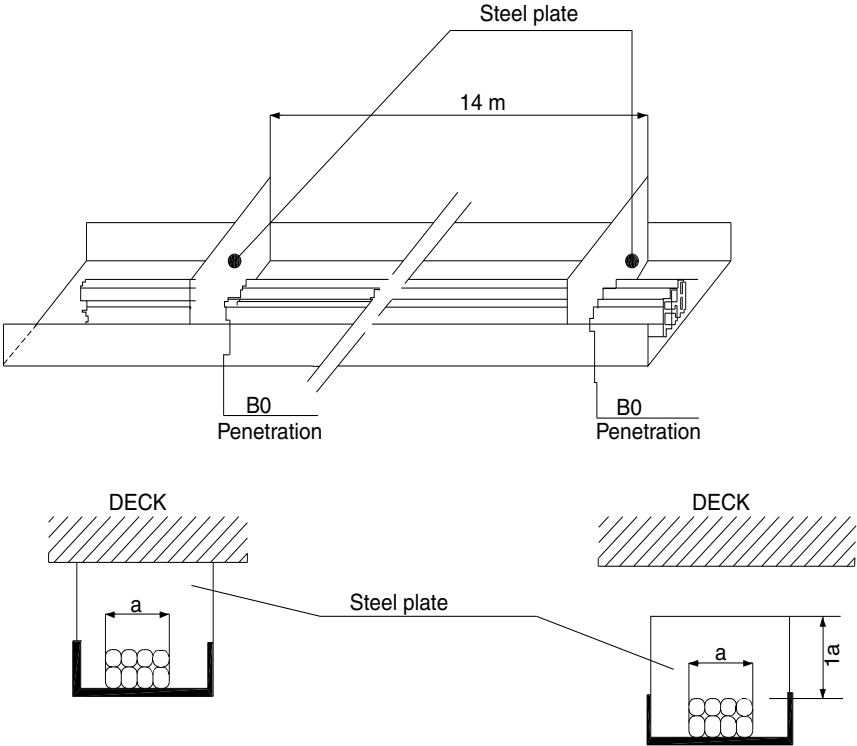
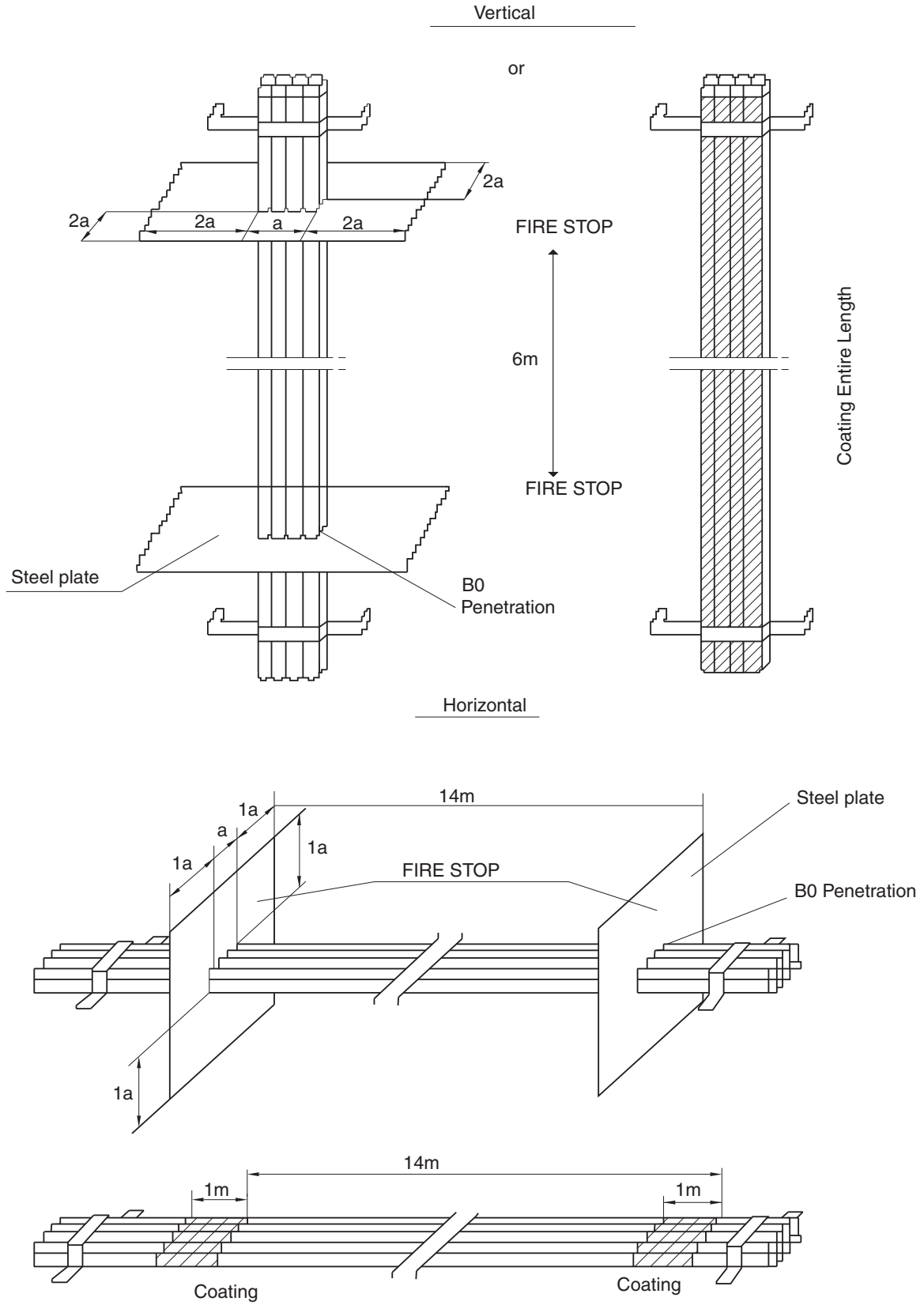

Figure 4 : Open cables runs



7.3 Fixing of cables

7.3.1 Cables shall be installed and supported in such a manner as to avoid chafing or other damage.

7.3.2 The supports (tray plates, separate support brackets or hanger ladders) and the corresponding accessories are to be of robust construction and of corrosion-resistant material or suitably treated before erection to resist corrosion.

When cables are installed directly on aluminium structures, fixing devices of aluminium or suitably treated steel are to be used.

For mineral-insulated cables with copper sheath, fixing devices in contact with the sheath are to be of copper alloy.

7.3.3 With the exception of cables installed in pipes, conduits, trunkings or special casings, cables are to be fixed by means of clips, saddles or straps of suitable material, in order to tighten the cables without their coverings being damaged.

7.3.4 Cable clips or straps made from a material other than metal are to be manufactured of a flame-retardant material.

7.3.5 The distances between fastenings and between supports are to be suitably chosen according to the type and number of cables and the probability of vibration.

7.3.6 When cables are fixed by means of clips or straps made from a material other than metal and these cables are not laid on top of horizontal cable supports (e.g. in the case of vertical installation), suitable metal clips or saddles spaced not more than 1 metre apart are to be used in addition in order to prevent the release of cables during a fire.

7.3.7 Suspended cables of fire-resisting type are to be fixed by means of steel straps spaced not more than 500 mm apart.

7.4 Mechanical protection

7.4.1 Cables exposed to risk of mechanical damage are to be protected by metal casing, profiles or grids or enclosed in metal pipes or conduits, unless the cable covering (e.g. armour or sheath) provides adequate mechanical protection.

7.4.2 In situations where there would be an exceptional risk of mechanical damage, e.g. in holds, storage spaces, cargo spaces, etc., cables are to be protected by metal casing, trunkings or conduits, even when armoured, if the ship's structure or attached parts do not afford sufficient protection for the cables.

7.4.3 For the protection of cables passing through decks, see [7.5.3].

7.4.4 Metal casing used for mechanical protection of cables is to be effectively protected against corrosion.

7.5 Penetrations of bulkheads and decks

7.5.1 If cables have to pass without adequate support through non-watertight bulkheads and generally through holes drilled in sheets of structural steel, these holes are to be fitted with glands or bushings of suitable material.

7.5.2 If cables have to pass through a watertight bulkhead or deck, the penetration is to be effected in a watertight manner.

Either suitable individual watertight glands for single cables or boxes containing several cables and filled with a flame-retardant packing may be used for this purpose.

Whichever type of penetration is used, the watertight integrity of the bulkheads or deck is to be maintained.

7.5.3 Cables passing through decks and continuing vertically are to be protected against mechanical damage to a suitable height above the deck.

7.5.4 Where cables pass through bulkheads or decks separating areas with a risk of explosion, arrangements are to be such that hazardous gas or dust cannot penetrate through openings for the passage of cables into other areas.

7.5.5 Where cables pass through a bulkhead or deck which is required to have some degree of fire integrity, penetration is to be so effected as to ensure that the required degree of fire integrity is not impaired.

7.6 Expansion joints

7.6.1 If there is reason to fear that a tray plate, pipe or conduit may break because of the motion of the ship, different load conditions and temperature variations, appropriate expansion joints are to be provided.

This may apply in particular in the case of cable runs on the weather deck.

7.7 Cables in closed pipes or conduits

7.7.1 Closed pipes or conduits are to have such internal dimensions and radius of bend as will permit the easy drawing in and out of the cables which they are to contain; the internal radius of bend is to be not less than that permitted for cables and, for pipes exceeding 63 mm external diameter, not less than twice the external diameter of the pipe where this value is greater.

7.7.2 Closed pipes and conduits are to be suitably smooth on the interior and are to have their ends shaped or bushed in such a way as not to damage the cable covering.

7.7.3 The space factor (ratio of the sum of the cross-sectional areas corresponding to the external diameters of the cables to the internal cross-sectional areas of the pipe or conduit) is to be not greater than 0,4.

7.7.4 If necessary, openings are to be provided at the highest and lowest points so as to permit air circulation and ensure that the heat from the cables can be dissipated, and to obviate the possibility of water accumulating at any part of the pipe or conduit.

7.7.5 Vertical trunking for electrical cables is to be so constructed as not to jeopardise the required passive fire protection between the spaces.

7.7.6 Metal pipes or conduits are to be protected against corrosion.

7.7.7 Non-metallic pipes or conduits are to be flame-retardant.

7.8 Cables in casings or trunking and conduits with removable covers

7.8.1 Covers are to be removable and when they are open, cables are to be accessible.

7.8.2 Materials used are to comply with [7.7.6] and [7.7.7].

7.8.3 If the fixing of covers is by means of screws, the latter are to be of non-rusting material and arranged so as not to damage the cables.

7.8.4 Means are to be provided to ensure that the heat from the cables can be dissipated and water accumulation is avoided (see [7.7.4]).

7.9 Cable ends

7.9.1 Terminations in all conductors are to be so made as to retain the original electrical, mechanical, flame-retarding properties of the cable.

7.9.2 Where mechanical clamps are not used, the ends of all conductors having a cross-sectional area greater than 4 mm² are to be fitted with soldering sockets or compression-type sockets of sufficient size to contain all the strands of the conductor.

7.9.3 Cables not having a moisture-resistant insulation (e.g. mineral-insulated) are to have their ends effectively sealed against ingress of moisture.

7.10 Joints and tappings (branch circuit)

7.10.1 Cable runs are normally not to include joints. Where absolutely necessary, cable joints are to be carried out by a junction method with rebuilding of the insulation and protective coverings.

7.10.2 Joints in all conductors are to be so made as to retain the original electrical (continuity and isolation), mechanical (strength and protection), flame-retarding and, where necessary, fire-resisting properties of the cable.

7.10.3 Tappings (branch circuits) are to be made via suitable connections or in suitable boxes of such design that the conductors remain adequately insulated and protected from atmospheric action and are fitted with terminals or busbars of dimensions appropriate to the current rating.

7.10.4 Cables for safety voltages are not to terminate in the same connection boxes as cable for higher voltages unless separated by suitable means.

7.11 Earthing and continuity of metal coverings of cables

7.11.1 All metal coverings of cables are to be electrically connected to the metal hull of the ship.

7.11.2 Metal coverings are generally to be earthed at both ends of the cable, except for [7.11.3] and [7.11.4].

7.11.3 Single-point earthing is admitted for final sub-circuits (at the supply end), except for those circuits located in areas with a risk of explosion.

7.11.4 Earthing is to be at one end only in those installations (mineral-insulated cables, intrinsically safe circuits, control circuits (see Ch 3, Sec 7), etc.) where it is required for technical or safety reasons.

7.11.5 Metal coverings of single-core a.c. cables and special d.c. cables with high "ripple" content (e.g. for thyristor equipment) are to be earthed at one point only (e.g. at the mid-point).

7.11.6 The electrical continuity of all metal coverings of cables throughout the length of the latter, particularly at joints and tappings, is to be ensured.

7.11.7 The metal covering of cables may be earthed by means of glands intended for the purpose and so designed as to ensure an effective earth connection.

The glands are to be firmly attached to, and in effective electrical contact with, a metal structure earthed in accordance with these requirements.

7.11.8 The metal covering of cables may also be earthed by means of clamps or clips of corrosion-resistant material making effective contact with the covering and earthed metal.

7.12 Earthing and continuity of metal pipes, conduits and trunking or casings

7.12.1 Metal casings, pipes, conduits and trunking are to be effectively earthed.

7.12.2 Pipes or conduits may be earthed by being screwed into a metal enclosure, or by nuts on both sides of the wall of a metallic enclosure, provided the surfaces in contact are clean and free from rust, scale or paint and that the enclosure is in accordance with these requirements on earthing.

The connection is to be painted immediately after assembly in order to inhibit corrosion.

7.12.3 Pipes and conduits may be earthed by means of clamps or clips of corrosion-resistant metal making effective contact with the earthed metal.

7.12.4 Pipes, conduits or trunking together with connection boxes of metallic material are to be electrically continuous.

7.12.5 All joints in metal pipes and conduits used for earth continuity are to be soundly made and protected, where necessary, against corrosion.

7.12.6 Individual short lengths of pipes or conduits need not be earthed.

7.13 Precautions for single-core cables for a.c.

7.13.1 For the earthing of metal coverings see [7.11.5].

7.13.2 Where it is necessary to use single-core cables for alternating current circuits rated in excess of 20 A, the requirements of [7.13.3] to [7.13.7] are to be complied with.

7.13.3 Conductors belonging to the same circuit are to be contained within the same pipe, conduit or trunking, unless this is of non-magnetic material.

7.13.4 Cable clips are to include cables of all phases of a circuit unless the clips are of non-magnetic material.

7.13.5 In the installation of two, three or four single-core cables forming respectively single-phase circuits, three-phase circuits, or three-phase and neutral circuits, the cables are to be in contact with one another, as far as possible. In any event, the distance between the external covering of two adjacent cables is to be not greater than one diameter.

7.13.6 When single-core cables having a current rating greater than 250 A are installed near a steel bulkhead, the clearance between the cables and the bulkhead is to be at least 50 mm, unless the cables belonging to the same circuit are installed in trefoil twisted formation.

7.13.7 Magnetic material is not to be used between single-core cables of a group. Where cables pass through steel plates, all the conductors of the same circuit are to pass through a plate or gland, so made that there is no magnetic material between the cables, and the clearance between the cables and the magnetic material is to be no less than 75 mm, unless the cables belonging to the same circuit are installed in trefoil twisted formation.

7.14 Cables in refrigerated spaces

7.14.1 For the types of cables permitted in refrigerated spaces, see Sec 3, [9.4].

7.14.2 Power cables installed in refrigerated spaces are not to be covered by thermal insulation. Moreover, such cables are not to be placed directly on the face of the refrigerated space unless they have a thermoplastic or elastomeric extruded sheath.

7.14.3 Power cables entering a refrigerated space are to pass through the walls and thermal insulation at right angles, in tubes sealed at each end and protected against oxidation.

7.15 Cables in areas with a risk of explosion

7.15.1 For the types of cables permitted in areas with a risk of explosion, see Sec 3, [10.2].

7.15.2 For penetration of bulkheads or decks separating areas with a risk of explosion, see [7.5.4].

7.15.3 Cables of intrinsically safe circuits are to be separated from the cables of all other circuits (minimum 50 mm).

7.16 Cables in the vicinity of radio equipment

7.16.1 All cables between antennas and transmitters are to be routed separately of any other cable.

7.16.2 Where it is necessary to use single-core cables, the arrangement of conductors is to be such as to avoid complete or partial loops.

7.17 Cables for submerged bilge pumps

7.17.1 See Sec 3, [9.7].

8 Various appliances

8.1 Lighting fittings

8.1.1 Lighting fittings are to be so arranged as to prevent temperature rises which could damage the cables and wiring.

Note 1: Where the temperature of terminals of lighting fittings exceeds the maximum conductor temperature permitted for the supplied cable (see Sec 3, [9.9]), special installation arrangements, such as terminal boxes thermally insulated from the light source, are to be provided.

8.1.2 Lighting fittings are to be so arranged as to prevent surrounding material from becoming excessively hot.

8.1.3 Lighting fittings are to be secured in place such that they cannot be displaced by the motion of the vessel.

8.2 Heating appliances

8.2.1 Space heaters are to be so installed that clothing, bedding and other flammable material cannot come in contact with them in such a manner as to cause risk of fire.

Note 1: To this end, for example, hooks or other devices for hanging garments are not to be fitted above space heaters or, where appropriate, a perforated plate of incombustible material is to be mounted above each heater, slanted to prevent hanging anything on the heater itself.

8.2.2 Space heaters are to be so installed that there is no risk of excessive heating of the bulkheads or decks on which or next to which they are mounted.

8.2.3 Combustible materials in the vicinity of space heaters are to be protected by suitable incombustible and thermal-insulating materials.

8.3 Heating cables and tapes or other heating elements

8.3.1 Heating cables and tapes or other heating elements are not to be installed in contact with combustible materials.

Where they are installed close to such materials, they are to be separated by means of a non-flammable material.

SECTION 13

HIGH VOLTAGE INSTALLATIONS

1 General

1.1 Field of application

1.1.1 (1/1/2002)

The following requirements apply to a.c. three-phase systems with nominal voltage exceeding 1kV, the nominal voltage being the voltage between phases.

If not otherwise stated herein, construction and installation applicable to low voltage equipment generally apply to high voltage equipment.

1.2 Nominal system voltage

1.2.1 (1/1/2002)

The nominal system voltage is not to exceed 15 kV.

Note 1: Where necessary for special application, higher voltages may be accepted by the Society.

1.3 High-voltage, low-voltage segregation

1.3.1 (1/1/2002)

Equipment with voltage above about 1 kV is not to be installed in the same enclosure as low voltage equipment, unless segregation or other suitable measures are taken to ensure that access to low voltage equipment is obtained without danger.

2 System Design

2.1 Distribution

2.1.1 Network configuration for continuity of ship services (1/1/2002)

It is to be possible to split the main switchboard into at least two independent sections, by means of at least one circuit breaker or other suitable disconnecting devices, each supplied by at least one generator. If two separate switchboards are provided and interconnected with cables, a circuit breaker is to be provided at each end of the cable.

Services which are duplicated are to be divided between the sections.

2.1.2 Earthed neutral systems (1/1/2002)

In the event of an earth fault, the current is not to be greater than full load current of the largest generator on the switchboard or relevant switchboard section and not less than three times the minimum current required to operate any device against earth fault.

It is to be assured that at least one source neutral to ground connection is available whenever the system is in the energised mode. Electrical equipment in directly earthed neutral or other neutral earthed systems is to withstand the current due to a single phase fault against earth for the time necessary to trip the protection device.

2.1.3 Neutral disconnection (1/1/2002)

Means of disconnection are to be fitted in the neutral earthing connection of each generator so that the generator may be disconnected for maintenance and for insulation resistance measurement.

2.1.4 Hull connection of earthing impedance (1/1/2002)

All earthing impedances are to be connected to the hull. The connection to the hull is to be so arranged that any circulating currents in the earth connections do not interfere with radio, radar, communication and control equipment circuits.

2.1.5 Divided systems (1/1/2002)

In systems with neutral earthed, connection of the neutral to the hull is to be provided for each section.

2.2 Degrees of protection

2.2.1 General (1/1/2002)

Each part of the electrical installation is to be provided with a degree of protection appropriate to the location, as a minimum the requirements of IEC 60092-201.

2.2.2 Rotating machines (1/1/2002)

The degree of protection of enclosures of rotating electrical machines is to be at least IP 23.

The degree of protection of terminals is to be at least IP44.

For motors installed in spaces accessible to unqualified personnel, a degree of protection against approaching or contact with live or moving parts of at least IP4X is required.

2.2.3 Transformers (1/1/2002)

The degree of protection of enclosures of transformers is to be at least IP23.

For transformers installed in spaces accessible to unqualified personnel a degree of protection of at least IP4X is required.

For transformers not contained in enclosures, see [8.1].

2.2.4 Switchgear, controlgear assemblies and convertors (1/1/2002)

The degree of protection of metal enclosed switchgear, controlgear assemblies and static convertors is to be at least IP32. For switchgear, control gear assemblies and static convertors installed in spaces accessible to unqualified personnel, a degree of protection of at least IP4X is required.

2.3 Insulation

2.3.1 (1/1/2002)

In general, for non Type Tested equipment phase-to-phase air clearances and phase-to-earth air clearances between non-insulated parts are to be not less than those specified in Tab 1.

Intermediate values may be accepted for nominal voltages provided that the next highest air clearance is observed.

In the case of smaller distances, an appropriate voltage impulse test is to be applied.

Table 1 : Minimum clearances (1/7/2004)

Rated voltage, in kV	Minimum clearance, in mm
3 - 3,3	55
6 - 6,6	90
10 - 11	120
15	160

2.3.2 (1/7/2016)

Creepage distances between live parts and between live parts and earthed metal parts are to be in accordance with IEC 60092-503 for the nominal voltage of the system, the nature of the insulation material and the transient overvoltage developed by switch and fault conditions.

2.4 Protection

2.4.1 Faults on the generator side of the circuit breaker (1/1/2002)

Protective devices are to be provided against phase-to-phase faults in the cables connecting the generators to the main switchboard and against interwinding faults within the generators. The protective devices are to trip the generator circuit breaker and to automatically de-excite the generator.

In distribution systems with a neutral earthed, phase to earth faults are also to be treated as above.

2.4.2 Faults to earth (1/7/2016)

Any earth fault in the system is to be indicated by means of a visual and audible alarm.

In low impedance or direct earthed systems provision is to be made to automatically disconnect the faulty circuits. In high impedance earthed systems, where outgoing feeders will not be isolated in case of an earth fault, the insulation of the equipment is to be designed for the phase to phase voltage (see Note 1).

A system is defined effectively earthed (low impedance) when earthing factor is lower than 0,8. A system is defined non-effectively earthed (high impedance) when earthing factor is higher than 0,8.

Note 1: Earthing factor is defined as the ratio between the phase to earth voltage of the health phase and the phase to phase voltage. This factor may vary between $1/\sqrt{3}$ and 1.

2.4.3 Power transformers (1/1/2002)

Power transformers are to be provided with overload and short circuit protection.

When transformers are connected in parallel, tripping of the protective devices on the primary side is to automatically trip the switch connected on the secondary side.

2.4.4 Voltage transformers for control and instrumentation (1/1/2002)

Voltage transformers are to be provided with overload and short circuit protection on the secondary side.

2.4.5 Fuses (1/1/2002)

Fuses are not to be used for overload protection.

2.4.6 Low voltage systems (1/1/2002)

Lower voltage systems supplied through transformers from high voltage systems are to be protected against overvoltages. This may be achieved by:

- a) direct earthing of the lower voltage system
- b) appropriate neutral voltage limiters
- c) earthed screen between the primary and secondary windings of transformers.

2.4.7 Arc Detection System (1/7/2017)

In order to limit the consequences of an internal arc to the high voltage main switchboard, measures may be adopted for a rapid fault-clearance times initiated by an Arc Detection System by means of detectors, e.g. sensitive to light, pressure or heat.

Where the Arc Detection System is fitted, the following requirements are to be complied with:

- a) Arc Detection Systems for each section of the main switchboard are to be independent
- b) The total disconnection of one section of the main switchboard, as a consequence of an arc fault, is permitted only when it is demonstrated that an arc fault located in any compartments of the switchboard (e.g. cable compartments, circuit breaker compartment, etc.) may jeopardise the operation of the entire switchboard
- c) The arrangement of the power supplies are to be in such a way that a failure inside the Arc Detection System will not cause the loss of generators and/or essential services.
- d) A failure analysis is to be carried out using appropriate means (e.g. FMEA) to demonstrate that, for single failures, system will fail to safety and that system in operation will not be lost or degraded beyond acceptable performance criteria. Faults are to be simulated as realistically as possible to demonstrate appropriate system fault detection and system response.
- e) The Arc Detection System, including relevant arc detectors, is to be type tested or type approved according to the tests listed in Ch 3, Sec 8, Tab 1.

3 Rotating machinery

3.1 Stator windings of generators

3.1.1 (1/1/2002)

Generator stator windings are to have all phase ends brought out for the installation of the differential protection.

3.2 Temperature detectors

3.2.1 (1/1/2002)

Rotating machinery is to be provided with temperature detectors in its stator windings to actuate a visual and audible alarm in a normally attended position whenever the temperature exceeds the permissible limit.

If embedded temperature detectors are used, means are to be provided to protect the circuit against overvoltage.

3.3 Tests

3.3.1 (1/1/2002)

In addition to the tests normally required for rotating machinery, a high frequency high voltage test in accordance with IEC 60034-15 is to be carried out on the individual coils in order to demonstrate a satisfactory withstand level of the inter-turn insulation to steep fronted switching surges.

4 Power Transformers

4.1 General

4.1.1 (1/7/2022)

Dry type transformers are to comply with IEC 60076-11.

Liquid cooled transformers are to comply with the applicable Parts of the IEC 60076 Series.

Oil immersed transformers are to be provided with the following alarms and protection:

- liquid level (Low) - alarm
- liquid temperature (High) - alarm
- liquid level (Low) - trip or load reduction
- liquid temperature (High) - trip or load reduction
- gas pressure relay (High) - trip

5 Cables

5.1 General

5.1.1 (1/1/2002)

Cables are to be constructed in accordance with IEC 60092-353 and 60092-354 or other equivalent Standard.

6 Fuses

6.1 General

6.1.1 (1/7/2015)

Fuses are to be constructed in accordance with IEC 60282-1 or other equivalent Standard.

7 Switchgear and controlgear assemblies

7.1 General

7.1.1 (1/1/2002)

Switchgear and controlgear assemblies are to be constructed according to IEC 62271-200 and the following additional requirements.

7.2 Construction

7.2.1 Mechanical construction (1/1/2002)

Switchgear is to be of metal - enclosed type in accordance with IEC 62271-200 or of the insulation - enclosed type in accordance with IEC 62271-201.

7.2.2 Locking facilities (1/1/2002)

Withdrawable circuit breakers and switches are to be provided with mechanical locking facilities in both service and disconnected positions. For maintenance purposes, key locking of withdrawable circuit breakers and switches and fixed disconnectors is to be possible.

Withdrawable circuit breakers are to be located in the service position so that there is no relative motion between fixed and moving portions.

7.2.3 Shutters (1/7/2016)

The fixed contacts of withdrawable circuit breakers and switches are to be so arranged that in the withdrawable position the live contacts are automatically covered.

Shutters are to be clearly marked for incoming and outgoing circuits; this is to be achieved with the use of colours or labels.

7.2.4 Earthing and short-circuiting (1/7/2016)

For maintenance purposes an adequate number of earthing and short-circuiting devices is to be provided to enable circuits to be worked upon with safety.

7.2.5 Internal Arc Classification (IAC) (1/7/2016)

Switchgear and controlgear assemblies are to be internal arc classified (IAC) in accordance with IEC 62271-200.

Where switchgear and controlgear are accessible by authorized personnel only, Accessibility Type A is sufficient. Where switchgear and controlgear are accessible by non-authorized personnel, accessibility Type B is required.

Installation and location of the switchgear and controlgear is to correspond with its internal arc classification and classified sides (F, L and R).

7.3 Auxiliary systems

7.3.1 Source of supply (1/1/2002)

If electrical energy and/or physical energy is required for the operation of circuit breakers and switches, a store supply of such energy is to be provided for at least two operations of all the components.

However, the tripping due to overload or short-circuit, and under-voltage is to be independent of any stored electrical energy sources. This does not preclude shunt tripping provided that alarms are activated upon lack of continuity in the release circuits and power supply failures.

7.3.2 Number of supply sources (1/7/2004)

When external supply is necessary for auxiliary circuits, at least two external sources of supply are to be provided and so arranged that a failure or loss of one source will not cause the loss of more than one generator set and/or set of essential services.

Where necessary, one source of supply is to be from the emergency source of electrical power for the start up from dead ship condition.

7.4 High voltage test

7.4.1 (1/1/2002)

A power-frequency voltage test is to be carried out on any switchgear and controlgear assemblies. The test procedure and voltages are to be according to IEC 62271-200.

8 Installation

8.1 Electrical equipment

8.1.1 (1/7/2016)

Where equipment is not contained in an enclosure but a room forms the enclosure of the equipment, the access doors are to be so interlocked that they cannot be opened until the supply is isolated and the equipment earthed down.

At the entrance to spaces where high-voltage electrical equipment is installed, a suitable marking is to be placed indicating danger of high-voltage. As regards high-voltage electrical equipment installed outside the aforementioned spaces, similar marking is to be provided.

An adequate, unobstructed working space is to be left in the vicinity of high voltage equipment for preventing potential severe injuries to personnel performing maintenance activities. In addition, the clearance between the switchboard and the ceiling/deckhead above is to meet the requirements of the Internal Arc Classification (see [7.2.5]).

8.2 Cables

8.2.1 Runs of cables (1/1/2002)

In accommodation spaces, high voltage cables are to be run in enclosed cable transit systems.

8.2.2 Segregation (1/1/2002)

High voltage cables are to be segregated from cables operating at different voltage ratings; in particular, they are not to be run in the same cable bunch, in the same ducts or pipes, or in the same box.

Where high voltage cables of different voltage ratings are installed on the same cable tray, the air clearance between cables is not to be less than the minimum air clearance for the higher voltage side in [2.3.1]. However, high voltage

cables are not to be installed on the same cable tray for cables operating at the nominal system voltage of 1 kV and less.

8.2.3 Installation arrangements (1/7/2016)

High voltage cables are generally to be installed on carrier plating cable tray when they are provided with a continuous metallic sheath or armour which is effectively bonded to earth; otherwise they are to be installed for their entire length in metallic castings effectively bonded to earth.

8.2.4 Terminations (1/1/2002)

Terminations in all conductors of high voltage cables are, as far as practicable, to be effectively covered with suitable insulating material. In terminal boxes, if conductors are not insulated, phases are to be separated from earth and from each other by substantial barriers of suitable insulating materials.

High voltage cables of the radial field type, i.e. having a conductive layer to control the electric field within the insulation, are to have terminations which provide electric stress control.

Terminations are to be of a type compatible with the insulation and jacket material of the cable and are to be provided with means to ground all metallic shielding components (i.e. tapes, wires etc).

8.2.5 Marking (1/1/2002)

High voltage cables are to be readily identifiable by suitable marking.

8.2.6 Test after installation (1/7/2019)

Before a new high voltage cable installation, or an addition to an existing installation, is put into service a voltage withstand test is to be satisfactorily carried out on each completed cable and its accessories.

The test is to be carried out after an insulation resistance test in accordance with Sec 15, [3.1.1].

For cables with rated voltage (U_0/U) above 1.8/3 kV ($U_m=3,6$ kV) an a.c. voltage withstand test is to be carried out upon advice from high voltage cable manufacturer. For this purpose, one of the following test methods are to be used:

- test for 5 min with the phase-to-phase voltage of the system applied between the conductor and the metallic screen/sheath;
- test for 24 h with the normal operating voltage of the system.

Alternatively, a d.c. voltage equal to $4 U_0$ is to be applied for 15 minutes.

For cables with rated voltage (U_0/U) up to 1.8/3 kV ($U_m=3.6$ kV) a d.c. voltage equal to $4 U_0$ is to be applied for 15 minutes.

After completion of the test the conductors are to be connected to earth for a sufficient period in order to remove any trapped electric charge.

An insulation resistance test in accordance with Sec 15, [3.1.1] is then repeated.

SECTION 14

ELECTRIC PROPULSION PLANT

1 General

1.1 Applicable requirements

1.1.1 The following requirements apply to ships for which the main propulsion plants are provided by at least one electric propulsion motor and its electrical supply. All electrical components of the propulsion plants are to comply with these requirements.

1.1.2 Prime movers are to comply with the requirements of Ch 1, Sec 2.

1.1.3 For the torsional vibration characteristics of the electric propulsion plant, the provisions of Ch 1, Sec 9 apply.

1.1.4 Cooling and lubricating oil systems are to comply with the requirements of Ch 1, Sec 10.

1.1.5 Monitoring and control systems are to comply with the requirements of Chapter 3.

1.1.6 Installations assigned an additional notation for automation are to comply with the requirements of Part F.

1.2 Operating conditions

1.2.1 The normal torque available on the electric propulsion motors for manoeuvring is to be such as to enable the vessel to be stopped or reversed when sailing at its maximum service speed.

1.2.2 Adequate torque margin is to be provided for three-phase synchronous motors to avoid the motor pulling out of synchronism during rough weather and when turning.

1.2.3 When an electric generating plant has a continuous rating greater than the electric propulsion motor rating, means are to be provided to limit the continuous input to the motor. This value is not to exceed the continuous full load torque for which motor and shafts are designed.

1.2.4 The plant as a whole is to have sufficient overload capacity to provide the torque, power and reactive power needed during starting and manoeuvring conditions.

Locked rotor torque which may be required in relation to the operation of the vessel (e.g. for navigation in ice) is to be considered.

1.2.5 The electric motors and shaftline are to be constructed and installed so that, at any speed reached in service, all the moving components are suitably balanced.

2 Design of the propulsion plant

2.1 General

2.1.1 The electrical power for the propulsion system may be supplied from generating sets, dedicated to the propulsion system, or from a central power generation plant, which supplies the ship's services and electric propulsion.

The minimum configuration of an electric propulsion plant consists of one prime mover, one generator and one electric motor. When the electrical production used for propulsion is independent of the shipboard production, the diesel engines driving the electric generators are to be considered as main engines.

2.1.2 For plants having only one propulsion motor controlled via a static convertor, a standby convertor which it is easy to switch over to is to be provided. Double stator windings with one convertor for each winding are considered as an alternative solution.

2.1.3 In electric propulsion plants having two or more constant voltage propulsion generating sets, the electrical power for the ship's auxiliary services may be derived from this source. Additional ship's generators for auxiliary services need not be fitted provided that effective propulsion and the services mentioned in Sec 3, [2.2.3] are maintained with any one generating set out of service.

Where transformers are used to supply the ship's auxiliary services, see Sec 5.

2.1.4 Plants having two or more propulsion generators, two or more static convertors or two or more motors on one propeller shaft are to be so arranged that any unit may be taken out of service and disconnected electrically, without affecting the operation of the others.

2.2 Power supply

2.2.1 Where the plant is intended exclusively for electric propulsion, voltage variations and maximum voltage are to be maintained within the limits required in Sec 2.

2.2.2 In special conditions (e.g. during crash-stop manoeuvres), frequency variations may exceed the limits stipulated in Sec 2 provided that other equipment operating on the same network is not unduly affected.

2.2.3 The electric plant is to be so designed as to prevent the harmful effects of electromagnetic interference generated by semiconductor convertors, in accordance with Sec 2.

2.3 Auxiliary machinery

2.3.1 Propeller/thruster auxiliary plants are to be supplied directly from the main switchboard or from the main distribution board or from a distribution board reserved for such circuits, at the auxiliary rated voltage.

2.3.2 When the installation has one or more lubrication systems, devices are to be provided to ensure the monitoring of the lubricating oil return temperature.

2.3.3 Propelling machinery installations with a forced lubrication system are to be provided with alarm devices which will operate in the event of oil pressure loss.

2.4 Electrical Protection

2.4.1 Automatic disconnections of electric propulsion plants which adversely affect the manoeuvrability of the ship are to be restricted to faults liable to cause severe damage to the equipment.

2.4.2 The following protection of convertors is to be provided:

- protection against overvoltage in the supply systems to which convertors are connected
- protection against overcurrents in semiconductor elements during normal operation
- short-circuit protection.

2.4.3 Overcurrent protective devices in the main circuits are to be set sufficiently high so that there is no possibility of activation due to the overcurrents caused in the course of normal operation, e.g. during manoeuvring or in heavy seas.

2.4.4 Overcurrent protection may be replaced by automatic control systems ensuring that overcurrents do not reach values which may endanger the plant, e.g. by selective tripping or rapid reduction of the magnetic fluxes of the generators and motors.

2.4.5 In the case of propulsion plants supplied by generators in parallel, suitable controls are to ensure that, if one or more generators are disconnected, those remaining are not overloaded by the propulsion motors.

2.4.6 In three-phase systems, phase-balance protective devices are to be provided for the motor circuit which de-excite the generators and motors or disconnect the circuit concerned.

2.5 Excitation of electric propulsion motor

2.5.1 Each propulsion motor is to have its own exciter.

2.5.2 For plants where only one generator or only one motor is foreseen, each machine is to be provided with a standby static electronic exciter, which it is easy to switch over to.

2.5.3 In the case of multi-propeller propulsion ships, one standby static electronic exciter which it is easy to switch over to is to be provided.

2.5.4 For the protection of field windings and cables, means are to be provided for limiting the induced voltage when the field circuits are opened. Alternatively, the induced voltage when the field circuits are opened is to be maintained at the nominal design voltage.

2.5.5 In excitation circuits, there is to be no overload protection causing the opening of the circuit, except for excitation circuits with semiconductor convertors.

3 Construction of rotating machines and semiconductor convertors

3.1 Ventilation

3.1.1 Where electrical machines are fitted with an integrated fan and are to be operated at speeds below the rated speed with full load torque, full load current, full load excitation or the like, the design temperature rise is not to be exceeded.

3.1.2 Where electrical machines or convertors are force-ventilated, at least two fans, or other suitable arrangements, are to be provided so that limited operation is possible in the event of one fan failing.

3.2 Protection against moisture and condensate

3.2.1 Machines and equipment which may be subject to the accumulation of moisture and condensate are to be provided with effective means of heating. The latter is to be provided for motors above 500 kW, in order to maintain the temperature inside the machine at about 3°C above the ambient temperature.

3.2.2 Provision is to be made to prevent the accumulation of bilge water, which is likely to enter inside the machine.

3.3 Rotating machines

3.3.1 Electrical machines are to be able to withstand the excess speed which may occur during operation of the ship.

3.3.2 The design of rotating machines supplied by static convertors is to consider the effects of harmonics.

3.3.3 The winding insulation of electrical machines is to be capable of withstanding the overvoltage which may occur in manoeuvring conditions.

3.3.4 The design of a.c. machines is to be such that they can withstand without damage a sudden short-circuit at their terminals under rated operating conditions.

3.3.5 The obtainable current and voltage of exciters and their supply are to be suitable for the output required during manoeuvring and overcurrent conditions, including short-circuit in the transient period.

3.4 Semiconductor convertors

3.4.1 The following limiting repetitive peak voltages U_{RM} are to be used as a base for each semiconductor valve:

- when connected to a supply specifically for propeller drives:

$$U_{RM} = 1,5 U_p$$

- when connected to a common main supply:

$$U_{RM} = 1,8 U_p$$

where

U_p : is the peak value of the rated voltage at the input of the semiconductor convertor.

3.4.2 For semiconductor convertor elements connected in series, the values in [3.4.1] are to be increased by 10%. Equal voltage distribution is to be ensured.

3.4.3 For parallel-connected convertor elements, an equal current distribution is to be ensured.

3.4.4 Means are to be provided, where necessary, to limit the effects of the rate of harmonics to the system and to other semiconductor convertors. Suitable filters are to be installed to keep the current and voltage within the limits given in Sec 2.

4 Control and monitoring

4.1 General

4.1.1 The control and monitoring systems, including programmable electronic systems, are to be type approved, according to Ch 3, Sec 8.

4.2 Power plant control systems

4.2.1 The power plant control systems are to ensure that adequate propulsion power is available, by means of automatic control systems and/or manual remote control systems.

4.2.2 The automatic control systems are to be such that, in the event of a fault, the propeller speed and direction of thrust do not undergo substantial variations.

4.2.3 Failure of the power plant control system is not to cause complete loss of generated power (i.e. blackout) or loss of propulsion.

4.2.4 The loss of power plant control systems is not to cause variations in the available power; i.e. starting or stopping of generating sets is not to occur as a result.

4.2.5 Where power-aided control (for example with electrical, pneumatic or hydraulic aid) is used for manual operation, failure of such aid is not to result in interruption of power to the propeller, any such device is to be capable of purely manual operation.

4.2.6 The control system is to include the following main functions:

- monitoring of the alarms: any event critical for the proper operation of an essential auxiliary or a main

element of the installation requiring immediate action to avoid a breakdown is to activate an alarm

- speed or pitch control of the propeller
- shutdown or slow down when necessary.

4.2.7 Where the electric propulsion system is supplied by the main switchboard together with the ship's services, load shedding of the non-essential services and /or power limitation of the electric propulsion is to be provided. An alarm is to be triggered in the event of power limitation or load shedding.

4.2.8 The risk of blackout due to electric propulsion operation is to be eliminated. At the request of the Society, a failure mode and effects analysis is to be carried out to demonstrate the reliability of the system.

4.3 Indicating instruments

4.3.1 In addition to the provisions of Chapter 3 of the Rules, instruments indicating consumed power and power available for propulsion are to be provided at each propulsion remote control position.

4.3.2 The instruments specified in [4.3.3] and [4.3.4] in relation to the type of plant are to be provided on the power control board or in another appropriate position.

4.3.3 The following instruments are required for each propulsion alternator:

- an ammeter on each phase, or with a selector switch to all phases
- a voltmeter with a selector switch to all phases
- a wattmeter
- a tachometer or frequency meter
- a power factor meter or a var-meter or a field ammeter for each alternator operating in parallel
- a temperature indicator for direct reading of the temperature of the stator windings, for each alternator rated above 500 kW.

4.3.4 The following instruments are required for each a.c. propulsion motor:

- an ammeter on the main circuit
- an embedded sensor for direct reading of the temperature of the stator windings, for motors rated above 500 kW
- an ammeter on the excitation circuit for each synchronous motor
- a voltmeter for the measurement of the voltage between phases of each motor supplied through a semiconductor frequency convertor.

4.3.5 Where a speed measuring system is used for control and indication, the system is to be duplicated with separate sensor circuits and separate power supply.

4.3.6 An ammeter is to be provided on the supply circuit for each propulsion semiconductor bridge.

4.4 Alarm system

4.4.1 An alarm system is to be provided, in accordance with the requirements of Chapter 3. The system is to give an indication at the control positions when the parameters specified in [4.4] assume abnormal values or any event occurs which can affect the electric propulsion.

4.4.2 Where an alarm system is provided for other essential equipment or installations, the alarms in [4.4.1] may be connected to such system.

4.4.3 (1/7/2004)

Critical alarms for propulsion may be grouped, but are to be indicated to the bridge separately from other alarms.

4.4.4 The following alarms are to be provided, where applicable:

- high temperature of the cooling air of machines and semiconductor convertors provided with forced ventilation (see Note 1)
- reduced flow of primary and secondary coolants of machines and semiconductor convertors having a closed cooling system with a heat exchanger
- leakage of coolant inside the enclosure of machines and semiconductor convertors with liquid-air heat exchangers
- high winding temperature of generators and propulsion motors, where required (see [4.3])
- low lubricating oil pressure of bearings for machines with forced oil lubrication
- tripping of protective devices against overvoltages in semiconductor convertors (critical alarm)
- tripping of protection on filter circuits to limit the disturbances due to semiconductor convertors
- tripping of protective devices against overcurrents up to and including short-circuit in semiconductor convertors (critical alarm)
- voltage unbalance of three-phase a.c. systems supplied by semiconductor frequency convertors
- earth fault for the main propulsion circuit (see Note 2)
- earth fault for excitation circuits of propulsion machines (see Note 3).

Note 1: As an alternative to the air temperature of convertors or to the airflow, the supply of electrical energy to the ventilator or the temperature of the semiconductors may be monitored.

Note 2: In the case of star connected a.c. generators and motors with neutral points earthed, this device may not detect an earth fault in the entire winding of the machine.

Note 3: This may be omitted in brushless excitation systems and in the excitation circuits of machines rated up to 500 kW. In such cases, lamps, voltmeters or other means are to be provided to detect the insulation status under operating conditions.

4.5 Reduction of power

4.5.1 Power is to be automatically reduced in the following cases:

- low lubricating oil pressure of bearings of propulsion generators and motors
- high winding temperature of propulsion generators and motors
- fan failure in machines and convertors provided with forced ventilation, or failure of cooling system
- lack of coolant in machines and semiconductor convertors
- load limitation of generators or inadequate available power.

4.5.2 When power is reduced automatically, this is to be indicated at the propulsion control position (critical alarm).

4.5.3 Switching-off of the semiconductors in the event of abnormal service operation is to be provided in accordance with the manufacturer's specification.

5 Installation

5.1 Ventilation of spaces

5.1.1 Loss of ventilation to spaces with forced air cooling is not to cause loss of propulsion. To this end, two sets of ventilation fans are to be provided, one acting as a standby unit for the other. Equivalent arrangements using several independently supplied fans may be considered.

5.2 Cable runs

5.2.1 Instrumentation and control cables are to comply with the requirements of Ch 3, Sec 7.

5.2.2 Where there is more than one propulsion motor, all cables for any one machine are to be run as far as is practicable away from the cables of other machines.

5.2.3 Cables which are connected to the sliprings of synchronous motors are to be suitably insulated for the voltage to which they are subjected during manoeuvring.

6 Tests

6.1 Test of rotating machines

6.1.1 The test requirements are to comply with Sec 4.

6.1.2 For rotating machines, such as synchronous generators and synchronous electric motors, of a power of more than 3 MW, a test program is to be submitted to the Society for approval.

6.1.3 In relation to the evaluation of the temperature rise, it is necessary to consider the supplementary thermal losses induced by harmonic currents in the stator winding. To this end, two methods may be used:

- direct test method, when the electric propulsion motor is being supplied by its own frequency convertor, and/or

back to back arrangement according to the supplier's facility

- indirect test method as defined in App 1; in this case, a validation of the estimation of the temperature excess due to harmonics is to be documented. A justification based on a computer program calculation may be taken into consideration, provided that validation of such program is demonstrated by previous experience.

7 Specific requirements for PODs

7.1 General

7.1.1 The requirements for the structural part of a POD are specified in Pt B, Ch 10, Sec 1, [11].

7.1.2 When used as steering manoeuvring system, the POD is to comply with the requirements of Ch 1, Sec 11.

7.2 Rotating commutators

7.2.1 As far as the electrical installation is concerned, the electric motor is supplied by a rotating commutator which rotates with the POD. The fixed part of the power transmission is connected to the ship supply, which uses the same components as a conventional propulsion system. Sliding contacts with a suitable support are used between the fixed and rotating parts.

7.2.2 (1/7/2003)

Type tests are to be carried out, unless the manufacturer can produce evidence based on previous experience indicating the satisfactory performance of such equipment on board ships.

7.2.3 A test program is to be submitted to the Society for approval. It is to be demonstrated that the power transmission and transmission of low level signals are not affected by the environmental and operational conditions prevailing on board. To this end, the following checks and tests are to be considered:

- check of the protection index (I.P.), in accordance with the location of the rotating commutator
- check of the clearances and creepage distances
- check of insulation material (according to the test procedure described in IEC Publication 60112)
- endurance test:

After the contact pressure and rated current are set, the commutator is subjected to a rotation test. The number of rotations is evaluated taking into consideration the ship operation and speed rotation control system. The

possibility of turning the POD 180° to proceed astern and 360° to return to the original position is to be considered. The commutator may be submitted to cycles comprising full or partial rotation in relation to the use of the POD as steering gear. The voltage drops and current are to be recorded.

An overload test is to be carried out in accordance with Sec 4 (minimum 150%, 15 seconds)

- check of the behaviour of the sliprings when subjected to the vibration defined in Ch 3, Sec 8
- check of the behaviour of the sliprings, after damp heat test, as defined in Chapter 3, and possible corrosion of the moving parts and contacts

After the damp heat test, are to be carried out the hereunder listed tests.

- Insulation measurement resistance test. The minimum resistance is to be in accordance with Sec 4, Tab 3.
- Dielectric strength test as defined in Sec 4.

7.3 Electric motors

7.3.1 The thermal losses are dissipated by the liquid cooling of the bulb and by the internal ventilation of the POD. The justification for the evaluation of the heating balance between the sea water and air cooling is to be submitted to the Society.

Note 1: The calculation method used for the evaluation of the cooling system (mainly based on computer programs) is to be documented. The calculation method is to be justified based on the experience of the designer of the system. The results of scale model tests or other methods may be taken into consideration.

7.3.2 Means to adjust the air cooler characteristics are to be provided on board, in order to obtain an acceptable temperature rise of the windings. Such means are to be set following the dock and sea trials.

7.4 Instrumentation and associated devices

7.4.1 Means are to be provided to transmit the low level signals connected to the sensors located in the POD.

7.5 Additional tests

7.5.1 Tests of electric propulsion motors are to be carried out in accordance with Sec 4, and other tests in accordance with Ch 1, Sec 16.

7.5.2 Tests are to be performed to check the validation of the temperature rise calculation.

SECTION 15

TESTING

1 General

1.1 Rule application

1.1.1 Before a new installation, or any alteration or addition to an existing installation, is put into service, the electrical equipment is to be tested in accordance with [3], [4] and [5] to the satisfaction of the Surveyor in charge.

1.2 Insulation-testing instruments

1.2.1 Insulation resistance may be measured with an instrument applying a voltage of at least 500 V. The measurement will be taken when the deviation of the measuring device is stabilised.

Note 1: Any electronic devices present in the installation are to be disconnected prior to the test in order to prevent damage.

2 Type approved components

2.1

2.1.1 (1/7/2023)

The following components are to be type tested or type approved according to the requirements in the present Chapter 2 and, excluding cables, transformers, rotating machines and converters (but not the relevant electronic control equipment), according to the tests listed in Ch 3, Sec 8, Tab 1, as far as applicable, or in accordance with [2.1.2]:

- electrical cables (internal wiring of equipment excluded)
- transformers
- rotating machines
- electrical convertors
- circuit-breakers, contactors, fuses and fuse-combination units used in power and lighting distribution systems, motor and transformer circuits, overcurrent protective devices
- sensors, alarm panels, electronic protective devices, automatic and remote control equipment, actuators, safety devices for installations intended for essential services (steering, controllable pitch propellers, propulsion machinery, etc.), electronic speed regulators for main or auxiliary engines, electronic devices for alarm, safety and control of electrical convertors for primary essential services and emergency services as defined in Sec 3, [3.7.3]
- programmable electronic systems intended for functions which are subject to classification requirements
- cable trays/protective casings made of plastic materials.

2.1.2 Case by case approval based on submission of adequate documentation and execution of tests may also be granted at the discretion of the Society.

3 Insulation resistance

3.1 Lighting and power circuits

3.1.1 The insulation resistance between all insulated poles (or phases) and earth and, where practicable, between poles (or phases), is to be at least 1 MΩ in ordinary conditions.

The installation may be subdivided to any desired extent and appliances may be disconnected if initial tests give results less than that indicated above.

3.2 Internal communication circuits

3.2.1 Circuits operating at a voltage of 50 V and above are to have an insulation resistance between conductors and between each conductor and earth of at least 1 MΩ.

3.2.2 Circuits operating at voltages below 50 V are to have an insulation resistance between conductors and between each conductor and earth of at least 0,33 MΩ.

3.2.3 If necessary, any or all appliances connected to the circuit may be disconnected while the test is being conducted.

3.3 Switchboards

3.3.1 (1/1/2021)

The insulation resistance between each busbar and earth and between each insulated busbar and the busbar connected to the other poles (or phases) of each main switchboard, emergency switchboard, distribution board, etc. is to be not less than 1 MΩ.

3.3.2 The test is to be performed before the switchboard is put into service with all circuit-breakers and switches open, all fuse-links for pilot lamps, earth fault-indicating lamps, voltmeters, etc. removed and voltage coils temporarily disconnected where otherwise damage may result.

3.4 Generators and motors

3.4.1 The insulation resistance of generators and motors, in normal working condition and with all parts in place, is to be measured and recorded.

3.4.2 The test is to be carried out with the machine hot immediately after running with normal load.

3.4.3 The insulation resistance of generator and motor connection cables, field windings and starters is to be at least 1 MΩ.

4 Earth

4.1 Electrical constructions

4.1.1 Tests are to be carried out, by visual inspection or by means of a tester, to verify that all earth-continuity conductors and earthing leads are connected to the frames of apparatus and to the hull, and that in socket-outlets having earthing contacts, these are connected to earth.

4.2 Metal-sheathed cables, metal pipes or conduits

4.2.1 Tests are to be performed, by visual inspection or by means of a tester, to verify that the metal coverings of cables and associated metal pipes, conduits, trunking and casings are electrically continuous and effectively earthed.

5 Operational tests

5.1 Generating sets and their protective devices

5.1.1 Generating sets are to be run at full rated load to verify that the following are satisfactory:

- electrical characteristics
- commutation (if any)
- lubrication
- ventilation
- noise and vibration level.

5.1.2 Suitable load variations are to be applied to verify the satisfactory operation under steady state and transient conditions (see Sec 4, [2]) of:

- voltage regulators
- speed governors.

5.1.3 Generating sets intended to operate in parallel are to be tested over a range of loading up to full load to verify that the following are satisfactory:

- parallel operation
- sharing of the active load
- sharing of the reactive load (for a.c. generators).

Synchronising devices are also to be tested.

5.1.4 The satisfactory operation of the following protective devices is to be verified:

- overspeed protection
- overcurrent protection (see Note 1)
- load-shedding devices
- any other safety devices.

For sets intended to operate in parallel, the correct operation of the following is also to be verified:

- reverse-power protection for a.c. installations (or reverse-current protection for d.c. installations)
- minimum voltage protection.

Note 1: Simulated tests may be used to carry out this check where appropriate.

5.1.5 The satisfactory operation of the emergency source of power and of the transitional source of power, when required, is to be tested. In particular, the automatic starting and the automatic connection to the emergency switchboard, in case of failure of the main source of electrical power, are to be tested.

5.2 Switchgear

5.2.1 All switchgear is to be loaded and, when found necessary by the attending Surveyor, the operation of overcurrent protective devices is to be verified (see Note 1).

Note 1: The workshop test is generally considered sufficient to ensure that such apparatus will perform as required while in operation.

5.2.2 Short-circuit tests may also be required at the discretion of the Society in order to verify the selectivity characteristics of the installation.

5.3 Consuming devices

5.3.1 Electrical equipment is to be operated under normal service conditions (though not necessarily at full load or simultaneously) to verify that it is suitable and satisfactory for its purpose.

5.3.2 Motors and their starters are to be tested under normal operating conditions to verify that the following are satisfactory:

- power
- operating characteristics
- commutation (if any)
- speed
- direction of rotation
- alignment.

5.3.3 The remote stops foreseen are to be tested.

5.3.4 Lighting fittings, heating appliances etc. are to be tested under operating conditions to verify that they are suitable and satisfactory for their purposes (with particular regard to the operation of emergency lighting).

5.4 Communication systems

5.4.1 Communication systems, order transmitters and mechanical engine-order telegraphs are to be tested to verify their suitability.

5.5 Installations in areas with a risk of explosion

5.5.1 Installations and the relevant safety certification are to be examined to ensure that they are of a type permitted in the various areas and that the integrity of the protection concept has not been impaired.

5.6 Voltage drop

5.6.1 Where it is deemed necessary by the attending Surveyor, the voltage drop is to be measured to verify that the permissible limits are not exceeded (see Sec 3, [9.11.4]).

APPENDIX 1

INDIRECT TEST METHOD FOR SYNCHRONOUS MACHINES

1 General

1.1 Test method

1.1.1 The machine is to be subjected to the three separate running tests specified below (see Fig 1) when it is completed (with covers, heat exchangers, all control devices and sensors), the exciter circuit is connected to its normal supply or to a separate supply having the same characteristics, and the supply is fitted with the necessary measuring instruments:

- Test N° 1: No load test at rated voltage and current on rotor, stator winding in open circuit. The temperature rise of the stator winding depends, in such case, on the magnetic circuit losses and mechanical losses due to ventilation, where:
 - Δt_{s1} is the stator temperature rise
 - Δt_{r1} is the rotor temperature rise
- Test N° 2: Rated stator winding current with the terminals short-circuited. The temperature of the stator winding depends on the thermal Joule losses and mechanical losses, as above, where:
 - Δt_{s2} is the stator temperature rise
 - Δt_{r2} is the rotor temperature rise, which for test N° 2 is negligible
- Test N° 3: Zero excitation. The temperature of all windings depends on the mechanical losses due to friction and ventilation, where:
 - Δt_{s3} is the stator temperature rise
 - Δt_{r3} is the rotor temperature rise.

Note 1: The synchronous electric motor is supplied at its rated speed by a driving motor. The temperature balance will be considered as being obtained, when the temperature rise does not vary by more than 1°C per hour.

1.1.2 Temperature measurements of the stator winding can be based on the use of embedded temperature sensors or measurement of winding resistance. When using the resist-

ance method for calculation of the temperature rise, the resistance measurement is to be carried out as soon as the machine is shut down.

The rotor temperature rise is obtained by calculation of rotor resistance, $R_{rotor} = (U/I)_r$, where U and I are the voltage and current in the magnetic field winding.

The following parameters are recorded, every 1/2 hour:

- temperature sensors as well as the stator current and voltage
- the main field voltage and current
- the bearing temperatures (embedded sensor or thermometer), and the condition of cooling of the bearings, which are to be compared to those expected on board.

1.1.3 The tests described above allow the determination of the final temperature rise of stator and rotor windings with an acceptable degree of accuracy.

- The temperature rise of the stator winding is estimated as follows:

$$\Delta t_{stator} = \Delta t_{s1} + \Delta t_{s2} - \Delta t_{s3}$$

Δt_{stator} winding is to be corrected by the supplementary temperature rise due to current harmonics evaluated by the manufacturer

- Considering that in test N° 1 the magnetic field winding current I_{rt} is different from the manufacturer's estimated value I_r (due to the fact that the $\cos \varphi$ in operation is not equal to 1), the temperature rise of the rotor is to be corrected as follows:

$$\Delta t_{rotor} = (\Delta t_{r1} - \Delta t_{r3}) \times (\text{rated loading conditions } I_r / \text{test loading conditions } I_{rt})^2 + \Delta t_{r3}$$

1.1.4 In the indirect method, a possible mutual influence of the temperature rise between the stator and the rotor is not taken into consideration. The test results may be representative of the temperature rise on board ship, but a margin of 10 to 15°C is advisable compared with the permitted temperature of the Rules and the measure obtained during tests.

Figure 1 : Schematic diagram used for the test

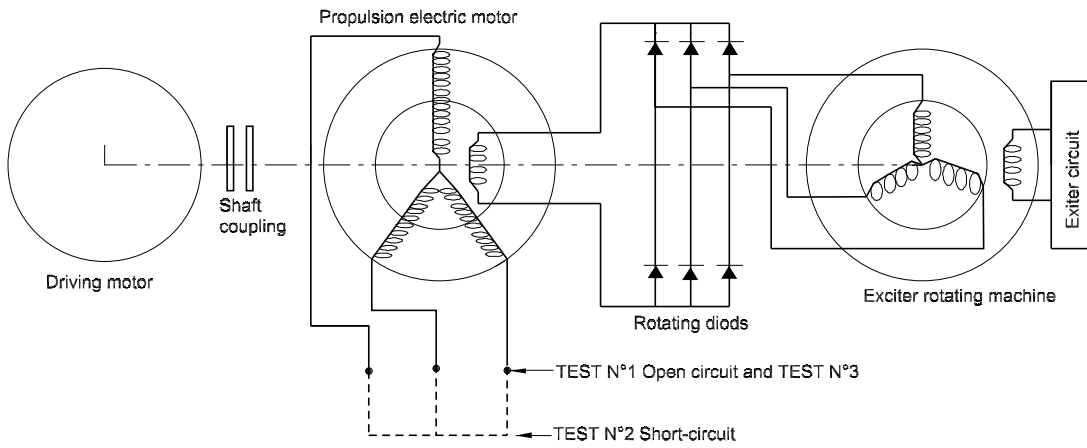

APPENDIX 2

BATTERY POWERED SHIPS

1 General

1.1 Application

1.1.1 (1/1/2022)

The provisions of this Appendix apply to ships where batteries, other than Lead and Nickel-Cadmium and Nickel-Metal-Hydrate batteries, are installed to supply essential or not-essential services and emergency services, except batteries embedded in consumer products like computers and similar appliances.

1.1.2 (1/1/2019)

The requirements in this Appendix are applicable to installations with a variety of lithium battery chemistry; since the battery technology is under development, additional requirements may be required by the Society on a case by case basis.

1.1.3 (1/1/2022)

The Society may consider different arrangements than those stated in this Appendix, provided that they ensure an equivalent level of safety, to be demonstrated by appropriate risk analysis techniques.

1.2 Definitions

1.2.1 (1/1/2022)

The following definitions and abbreviations are additional to those given in the other Parts of the Rules:

- Battery Management System (BMS): an electronic system that controls and monitors the state of the batteries by protecting the batteries from operating outside its safe operating area.
- Energy Management System (EMS): a system providing monitoring and control of the energy.
- Cell: an individual electrochemical unit of a battery consisting of electrodes, separators, electrolyte, container and terminals.
- Battery: assembly of cells ready for use as storage of electrical energy characterized by its voltage, size terminal arrangement, capacity and rate capability.
- Battery space: compartments (rooms, lockers or boxes) used primarily for accommodation of batteries .
- Battery system: the battery installation including battery banks, electrical interconnections, BMS and other safety features.

- Module: group of cells connected together either in a series and/or parallel configuration.
- State of Charge (SOC): state of charge expressed as a percentage of the rated capacity giving an indication of the energy available from the battery.
- State of Health (SOH): general condition of a battery, including its ability to deliver the specified performance compared with a new battery.
- Venting: release of excessive internal pressure from a cell/battery in a manner intended by design to preclude rupture or explosion.
- Explosion: failure that occurs when a cell container or battery case opens violently and major components are forcibly expelled.
- Fire: the emission of flames from a cell or battery.
- Upper limit of the charging voltage: the highest allowable charging voltage as specified by the cell Manufacturer.

1.3 Documentation to be submitted

1.3.1 (1/1/2019)

In addition to the documents required in Sec 1, for battery powered ships the plans and documents listed in Tab 1 are to be submitted.

The Society reserves the right to request the submission of additional documents in the case of non-conventional design or if it is deemed necessary for the evaluation of the systems and components.

2 System design

2.1 General

2.1.1 (1/1/2019)

Battery installations may replace generator sets in the main source of electrical power on condition that the capacity of the battery installation is sufficient for the intended operation of the ship and such design capacity is stated in the class certificate as an operational limitation.

2.1.2 (1/1/2019)

In ships or units where the main source of electrical power is based on battery installations only, the battery installation is to be divided into at least two independent battery systems located in two separate battery spaces, each having a capacity sufficient for the intended operation of the ship.

Table 1 : Documentation to be submitted (1/1/2022)

No.	A/I (1)	Document
1	A	Block diagram and electrical wiring diagram of the battery system and system interfaced to the battery system, including control, monitoring and alarm system, emergency shutdown, PMS, etc.
2	I	Technical specification of the batteries, including technical data (electrical characteristics like voltage and capacity, discharge and recharge rates), battery chemistry and functional description of cell/battery system including at least cell/batteries configuration, safety devices (BMS), interfaces to monitoring/safety, diagnostic, including the list of controlled and monitored parameters.
3	I	Functional description of the energy management system (EMS), when required (see [2.1.3]).
4	A	A risk assessment addressing all potential hazards represented by the type (chemistry) of batteries, the evaluation of the risk factors and measures to control and reduce the identified risks. Note: for the Risk Assessment reference is to be made to Tasneef "Guide for Risk Analysis".
5	A	Test program Note: the test program is to include the functional tests as per [5.2] (alarm system, safety system, control system, etc.) [5] and further tests, if any, resulting from the Risk Assessment for the specific battery system.
6	A	Electrical load balance capable of reflecting the operational mode stated in the battery system operating philosophy (maximum designed deterioration rate is to be included).
7	A	A general arrangement plan of battery installation including the indication of structural fire protection and the safety systems (2) (3).
8	I	Battery Manufacturer's instructions on active fire extinguishing system and confirmation about suitability of the proposed extinguishing agent for the specific type of batteries.
9	I	Statement of conformity of the batteries to IEC 62619, IEC 62620 and IEC 60529.
10	I	Copy of type approval certificate of the battery systems, when the aggregate capacity exceeds 20 kWh
11	I	An overall description of the battery system operating philosophy for each operational mode (including charging).
12	I	Operation and maintenance manuals including instructions for the safe connection/disconnection of batteries (see [5.4]).
13	A	Hazardous area classification (if applicable to the specific battery chemistry) and list of certified safety type electrical equipment installed in hazardous areas (as applicable).
14	I	Test Report of battery system at cellular, modular and system level in order to identify the damage potential of a possible thermal runaway event (Propagation Test) including gas analysis and explosion analysis as applicable and depending on the safety concept adopted.
15	I	Battery system maker statement confirming suitability of the selected fire extinguishing system and ventilation arrangement for the specific project.
<p>(1) A: to be submitted for approval I: to be submitted for information</p> <p>(2) Where a battery space is provided, based on the Risk Assessment (see [4.2]), evidence of the solution adopted for the battery space is to be given in the ship's active (detection and fighting) and passive fire protection, gas detection system and ventilation system drawings.</p> <p>(3) The plan has to show:</p> <ul style="list-style-type: none"> • the battery pack arrangement with respect to the space it is being installed in • the clearance distances between the other ancillary equipment in the space and the battery pack. 		

2.1.3 (1/1/2022)

When batteries are used as storage of power for the propulsion or dynamic positioning system or as part of the main source of electrical power, an Energy Management System (EMS) according to [3.5] is to be provided.

2.1.4 (1/1/2019)

Where the batteries are used for propulsion and steering of the ship, the system is to be so arranged that the electrical

supply to equipment necessary for propulsion and steering will be maintained or immediately restored in the case of battery system failure.

2.1.5 (1/1/2022)

Cables connecting each battery system to the main switchboard are to be arranged as per Sec 11, [5.2].

2.1.6 (1/1/2022)

A Risk Assessment, to be initiated in the design phase, is to be carried out to cover, but not limited to:

- evaluation of the risk factors,
- measures to control and reduce the identified risk, including potential gas development (e.g. toxic, corrosive), fire and explosion risk and
- action to be implemented.

The outcome of the assessment will give the additional measures to be adopted for minimizing the risks related to the use of batteries and among such measures, if the battery system needs to be installed in a space assigned to batteries only.

2.1.7 (1/1/2022)

The risk assessment has:

- to identify risks due to external heating, fire or flooding
- to identify any fault in the battery system that may cause malfunction to essential services including but not limited to propulsion and steering or to emergency services and measures to mitigate the related risk,
- to evaluate any risk related to the location of batteries in the same space with other system supporting ship's essential or emergency services, including pipes and electrical cables, distribution switchboards and so on, including but not limited to thermal runaway of the battery system, external and internal short-circuit,
- to evaluate any risk related to the location, in the same space, of batteries and other systems related to non essential services,
- to address sensor failures (e.g. temperature measurement sensor failure, individual cell voltage measurement sensor failure) and alarm, control and safety system failures (e.g. BMS and EMS failures including power and communication failures),
- to assess the selected fire extinguishing and ventilation arrangement according to battery system maker guidelines considering the specific design features of the ship.

2.1.8 (1/1/2019)

Battery cells of different physical characteristics, chemistries and electrical parameters are not to be used in the same electrical circuit.

2.1.9 (1/1/2019)

The batteries are to be properly located (see [4]) and, where necessary, insulated to prevent overheating of the system.

2.1.10 (1/1/2022)

The minimum required degree of protection is to be, in relation to place of installation of the battery system, according to Sec 3, [4]. Where water-based fire extinguishing system is used in the battery space, IP 44 is required as a minimum (see Note 1 and Note 2).

Note 1: if other fire-extinguish systems are used, the minimum IP can be reduced as result of the risk assessment.

Note 2: where the risk assessment identifies risks from water immersion (e.g. when batteries are installed below the freeboard deck), the batteries are to have a minimum degree of protection IP X7.

2.2 Constructional requirements**2.2.1 (1/1/2019)**

Battery enclosure covering modules and cells are to be made of flame retardant materials.

2.2.2 (1/1/2019)

Each cell or battery case is to incorporate a pressure relief mechanism or is to be constructed in such a way to relieve excessive internal pressure at a value and rate that will be precluded rupture, explosion and self-ignition.

2.2.3 (1/1/2019)

A thermal protection device, capable to disconnect the battery in case of high temperature, is to be provided in the battery.

2.2.4 (1/1/2022)

The design and construction of battery modules have to reduce the risk of a thermal propagation due to a cell thermal runaway, maintaining it confined at the lowest possible level (e.g. confined within a module). This may be achieved by means of partition plates or sufficient distance in accordance with maker recommendation to prevent escalation between battery modules in case of a thermal runaway.

2.2.5 (1/1/2019)

Terminals are to have clear polarity marking on the external surface of the battery. The size and shape of the terminal contacts are to ensure that they can carry the maximum current. External terminal contact surfaces are to be made of conductive materials with good mechanical strength and corrosion resistance. Terminal contacts are to be arranged so as to minimize the risk of short circuits.

2.2.6 (1/1/2022)

The battery system is to be provided with a Battery Management System (BMS) according to [3.2].

2.3 Electrical protection**2.3.1 (1/1/2022)**

The outgoing circuits of the battery system are to be protected against overload and short-circuit by means of fuses or multi-pole circuit breakers having isolating capabilities.

2.3.2 (1/1/2022)

An emergency shutdown system is to be installed and capable of disconnecting the battery system in an emergency.

2.3.3 (1/1/2022)

The battery system is to have means for isolating purpose for maintenance purposes. This isolating device is to be independent of the emergency shutdown arrangement.

2.4 Battery charger**2.4.1 (1/1/2022)**

Battery chargers are to comply with the requirements of Sec 7.

2.4.2 (1/1/2019)

The battery charger is to be designed to operate without exceeding the limits given by the battery system Manufacturer (e.g. current and voltage level).

2.4.3 (1/1/2022)

The battery charger is to be interfaced with and controlled by the BMS.

2.4.4 (1/1/2022)

Any failure in the battery charger, including charging/discharging failure, is to give an alarm in a continuously manned control position.

3 Control, monitoring, alarm and safety systems

3.1 General

3.1.1 (1/1/2019)

For the purpose of these rules, unless differently state in the text, a required alarm is to be intended as an audible and visual alarm and is to be given in a continuously manned control position.

3.1.2 (1/1/2022)

Control, monitoring, alarm and safety systems are to comply with the requirements of Chapter 3 and are to be type approved or type tested according to Ch 3, Sec 8.

3.2 Battery management systems (BMS)

3.2.1 (1/1/2019)

The BMS and related monitoring and safety systems (see [3.4]) are to have self-check facilities.

In the event of a failure, an alarm is to be activated.

3.2.2 (1/1/2019)

The BMS is to be continuously powered so that a single failure of the power supply system does not cause any degradation of the BMS functionality; an alarm is to be given in the event of failure of any of the power supplies.

Unless the power supply is derived from different strings of batteries, one of the power supplies is to be derived from the emergency source of electrical power.

Where each battery is fitted with a BMS card, the individual cards may have a single power supply from the relevant battery.

An alarm is to be given and safety action taken in the event of loss of all the power supplies.

3.2.3 (1/1/2022)

The battery management system (BMS) is to:

- provide limits for charging and discharging of the battery,
- protect against over-current, over-voltage and under-voltage by disconnection of the battery system,
- protect against over-temperature by disconnection of the battery system,
- provide cell and module balancing.

3.2.4 (1/1/2022)

The following parameters are to be continuously monitored and indications are to be provided at a local control panel and in a continuously manned control position for:

- system voltage,
- max, min, average cell voltage,
- max, min and average cell or module temperature,
- battery string current.

3.2.5 (1/1/2019)

When battery system is used as storage of power for the propulsion system or as part of the main source of electrical power, State of Charge (SOC) and State of Health (SOH) of the batteries are to be displayed at a continuously manned control station.

3.3 Alarm system

3.3.1 (1/1/2019)

Abnormal conditions which can develop into safety hazards are to be alarmed before reaching the hazardous level.

3.3.2 (1/1/2019)

Any abnormal condition in the battery system is to initiate an alarm.

3.3.3 (1/1/2019)

At least the following conditions or events have to initiate an alarm at a local control panel and in a continuously manned control position:

- safety intervention of the BMS of the battery system,
- high ambient temperature,
- failure of cooling system or leakage of liquid cooling system,
- low ventilation flow inside the battery room,
- overvoltage and undervoltage,
- cell voltage unbalance,
- high cell temperature,
- other safety protection functions.

Other possible abnormal conditions are to be considered on the basis of the outcome of the Risk Assessment (see [2.1.7]) and relevant mitigating measures are to be adopted.

3.3.4 (1/1/2019)

When batteries are used as storage of power for the propulsion or dynamic positioning systems or as part of the main source of electrical power, an alarm is to be given on the bridge when State of Charge (SOC) reaches minimum required capacity for ship intended operations.

3.4 Safety system

3.4.1 (1/1/2022)

The safety systems are to be:

- designed so as to limit the consequence of internal failures (e.g. failure in the safety system is not to cause shut down of battery system)
- self-monitoring,
- capable of acting on the controlled system following the fail-to safety principle,
- capable of detecting sensor malfunctions.

3.4.2 (1/1/2019)

The safety systems are to be activated automatically in the event of identified conditions which could lead to damage of the battery system. Activation of any automatic safety actions is to activate an alarm. Manual override of safety functions is not to be possible.

3.4.3 (1/1/2019)

Voltage of any one of the single cells is not to exceed the upper limit of the charging voltage as specified by the cell Manufacturer. The battery charger is to be stopped when the upper limit of the charging voltage is exceeded for any one of the single cells.

3.4.4 (1/1/2022)

An emergency shutdown (ESD) system is to be arranged as a separated hardwired circuit and it is to be independent from the control system.

3.4.5 (1/1/2019)

Activation means of the ESD are to be provided locally, from outside the battery space, and from a continuously manned control station.

3.4.6 (1/1/2019)

When battery installation is used as storage of power for the propulsion or dynamic positioning systems or as part of the main source of electrical power, the emergency shutdown is also to be located on the bridge.

3.4.7 (1/1/2019)

When battery installation is used as storage of power for the propulsion or DP systems or as part of the main source of electrical power, in case of over temperature in the battery system, an alarm and a request of manual load reduction is to be given on the bridge at a temperature lower than the one causing intervention of the BMS. As an alternative an automatic load reduction system may be provided. Its intervention is to generate an alarm.

3.4.8 (1/1/2019)

Other possible abnormal conditions, which could lead to damage or additional hazards to battery system, are to be considered on the basis of the outcome of the Risk Assessment.

3.4.9 (1/1/2019)

Sensors are to be designed to withstand the local environment.

3.4.10 (1/1/2019)

The enclosure of the sensor and the cable entry are to be appropriate to the space in which they are located.

3.4.11 (1/1/2019)

Cables to be operable under fire conditions (e.g. where required as result of the Risk Assessment), are to be of a fire-resistant type complying with IEC Publication 60331 series.

3.5 Energy Management system**3.5.1 (1/1/2022)**

When required per [2.1.3], an energy management system (EMS) is to be provided complying with the requirements of

Chapter 3 consisting of several levels of controls and alarm functions, such as:

- monitoring and alarm functions of all power sources, inverters and disconnectors;
- voltage and power control for DC distribution system;
- available power and charge/discharge status of the storage energy source;
- interface with Power Management System (PMS) for combinations of AC and DC distribution systems;
- inverter control for the overall system.

The energy management system (EMS) is to be independent from the battery management system (BMS) for lithium batteries, however EMS may be integrated in the PMS.

The EMS is to be continuously supplied by uninterruptible power supply systems (UPS) and a failure is to initiate an alarm in a manned location.

The energy management system is to be type tested or type approved according to the tests listed in Ch 3, Sec 8, Tab 1, as far as applicable (see Note 1).

Note 1: If the energy management functionality is implemented in another system, e.g. as part of the power management system (PMS), then the systems are to be certified together.

3.5.2 (1/1/2019)

The EMS is to be capable to provide at least the following information on the bridge:

- energy available from batteries (SOC),
- power available from batteries,
- time or range for which the battery can provide energy according to actual operational conditions,
- alarm for minimum capacity reached,
- battery state of health (SOH).

4 Location**4.1 General****4.1.1 (1/1/2022)**

Batteries are to be arranged aft of collision bulkhead and in such a way that danger to persons and damage to vessel due to failure of the batteries (e.g. caused by gassing, explosion, and fire) is minimized.

4.1.2 (1/1/2019)

Batteries are not to be located in a battery box on the open deck exposed to sun and frost.

They are to be located where they are not exposed to excessive heat, extreme cold, spray, steam, shocks or vibration or other conditions which would impair their safety, performance or accelerate deterioration.

4.1.3 (1/1/2019)

Batteries are to be located in such a way that the ambient temperature remains within the Manufacturer's specification at all times.

4.1.4 (1/1/2022)

Batteries are to be suitably housed by means of compartments (rooms, lockers or boxes) which are to be properly constructed and efficiently ventilated and cooled (as necessary) in such a way to keep the battery system at a specified set of environmental conditions.

4.1.5 (1/1/2019)

Battery system is to be arranged following the Manufacturer's prescriptions in particular to prevent cascade effects in case of a thermal runaway (e.g. partition plates or distance in accordance with Manufacturer's recommendations).

4.1.6 (1/1/2022)

Batteries, used as storage of power for the propulsion or dynamic positioning systems or as part of the main source of electrical power, are to be located in a battery space placed within the extreme borders of the main machinery space or adjacent to it.

4.1.7 (1/1/2022)

When the main source of electrical power is based on battery installations only, one of the two battery systems required in [2.1.2] is to be placed in a battery space located in the same machinery space of the main switchboard.

4.1.8 (1/1/2019)

Depending on the battery chemistry, it may be necessary to define a hazardous area for the installation of appropriate equipment (see Tab 1 No. 6).

4.2 Battery space

4.2.1 (1/1/2019)

When required, based on [4.1.6] or the Risk Assessment (see [2.1.6]), a space assigned to batteries only is to be foreseen.

4.2.2 (1/1/2019)

Access to this space is to be through self-closing doors. As an alternative normally closed doors with alarm may be considered.

4.2.3 (1/1/2019)

External hazards, such as fire and water ingress are to be taken into account in the Risk Assessment, in order to assess the risk associated with an external event (e.g. a fire spreading from adjacent rooms to the battery space, water flooding and so on) and possible countermeasures (e.g. suitable segregation of the battery space).

No heat sources or high fire risk equipment are to be located in battery spaces.

4.2.4 (1/1/2022)

A fire detection system and a fixed fire extinguishing system appropriate to the battery chemistry are to be provided in the battery space.

The type is to be chosen following the battery Manufacturer's instructions.

Examples of fire extinguishing systems may be a powder or a gas based or water-based fixed fire extinguishing system provided that the suitability of the extinguishing agent for the specific type of batteries is confirmed by the battery Manufacturer.

Automatic release is only acceptable for small, not accessible, battery spaces.

Where an automatic release of fire extinguishing media is accepted, its activation is to be confirmed by more than one sensor.

4.2.5 (1/1/2022)

The battery spaces are to be fitted with a forced ventilation system of extraction type, which is to be:

- independent from any other ventilation system serving other ship's spaces,
- provided with local manual stop, still available in case of failure of the automatic and or remote control system,
- provided with indication of ventilation running and of battery space ambient temperature,
- with a capacity (rate) according to battery manufacturer guidelines on the basis of the gas release identified in the gas analysis or propagation test,
- fitted with inlet from open air,
- fitted with exhaust outlet to open air far from accommodation and machinery ventilation inlets,
- fitted with non-sparking fans driven by a certified safe type electric motor in case the ventilation duct is considered to contain ex-plosive atmosphere in case of thermal runaway.

4.2.6 (1/1/2019)

Appropriate means to maintain the battery working temperature within the Manufacturer's declared limits are to be provided (e.g. by means of liquid cooled solutions or ventilation systems provided with control of air temperature).

4.2.7 (1/1/2022)

Battery modules with liquid cooling are to be designed such that the risk of a cooling liquid leakage inside the module is minimized.

The cooling system is to include at least two pumps for each primary and secondary circuits: one main and one standby. The standby pump can be omitted only if the consequences of main pump failure are addressed in the risk assessment [2.1.7].

4.2.8 (1/1/2022)

In case of liquid cooled solutions, a ventilation system is anyway required to extract possible gases or vapours in consequence of a battery abnormal condition.

4.2.9 (1/1/2019)

Depending on the battery chemistry, a gas detection system, for the gases that may be emitted from the battery system in the event of a serious fault, may be requested as an outcome of the risk assessment.

In this case,

- an alarm at 30% of LEL and automatic disconnection of batteries are to be provided,
- an alarm at 60% of LEL and automatic disconnection of all electrical equipment non certified of safety type for the specific hazardous area, gas, vapour are to be provided.

A failure in the gas detection system is to be alarmed but is not to cause above mentioned automatic disconnections.

4.2.10 (1/1/2022)

Depending on the battery chemistry, appropriate ventilation to prevent the formation of explosive atmospheres in the

battery space (e.g. to limit the concentration of flammable gasses and thereby reduce the risk for fire) is to be provided.

At this purpose the highest rate of gas emissions is to be considered.

4.2.11 (1/1/2019)

Depending on the battery chemistry, when a hazardous area is to be considered, mechanical exhaust non-sparking fan driven by a certified safe type electric motor, and inlet from open air are to be arranged.

4.2.12 (1/1/2019)

Battery spaces on passenger ships carrying more than 36 passengers are to be treated as a cat.11 space (auxiliary machinery space with high fire risk).

4.2.13 (1/1/2022)

Battery spaces on passenger ships carrying not more than 36 passengers, and on cargo ships are to be insulated in way of other spaces as indicated in Tab 2.

4.2.14 (1/1/2019)

Battery spaces are to be considered as spaces not normally manned.

4.2.15 (1/1/2022)

The battery space is not to contain other systems supporting essential or emergency services, including piping and electric cables serving such systems, in order to prevent their loss upon possible failures (e.g. thermal runaway) in the battery system.

Table 2 (1/1/2019)

Bulk-head	Control Station 1	Corridor 2	Accommodation spaces 3	Stairways 4	Service spaces (low risk) 5	Machinery Space of cat A 6	Machinery Space 7	Cargo 8	Service spaces (high risk) 9	Open deck 10	Special category/Roro spaces 11	Muster stations
Li Battery Space	A60	A15	A30	A15	A0	A60	A0	A60	A30	A0	A60	A60
Li Battery Space Below	A60	A60	A30	A60	A0	A60	A0	A60	A30	A0	A60	A60
Li Battery Space Above	A0	A0	A0	A0	A0	A60	A0	A60	A0	A0	A60	A60

5 Testing

5.1 General

5.1.1 (1/1/2022)

Battery systems are to be tested by the Manufacturer.

5.1.2 (1/1/2022)

Batteries are to be subjected to functional and safety tests according to IEC Publication 62619 and 62620 or in accordance with other equivalent national or international standards.

5.1.3 (1/1/2022)

When the aggregate capacity of a battery system exceeds the rating of 20 kWh, the battery system is to be of a type

approved in accordance with the Society "Rules for the type approval certification of lithium battery systems".

5.2 Testing and inspection at Manufacturer premises

5.2.1 (1/1/2022)

Battery systems are to be tested by the Manufacturer according to a test program proposed by the Manufacturer and approved by the Society and which is to include at least functional tests of battery system/BMS and control, monitoring and safety systems and further tests, if any, resulting from the Risk Assessment.

Table 3 (1/1/2022)

No.	Test/inspection
1	Examination of the technical documentation, as appropriate, and visual inspection
2	Functional test of the BMS, including safety functions and applicable alarms listed in [3.3.3]
3	Dielectrical strength (high voltage test) (1)
(1) Refer to Sec 8, [3.3] and Sec 8, [3.4]. In order to prevent damages to the electronic components of the battery system, the electronic components can be disconnected during the high voltage test.	

No.	Test/inspection
4	Insulation resistance test (1)
5	Sensor failure test (e.g. power supply failure, disconnection, short circuit, etc.)
6	Emergency shutdown (ESD) functional test
7	Communication failure between BMS and battery charger
8	Testing of the cooling system when submitted to acceptance testing together with the battery system
9	Check of test certificate for prescribed degree of protection
(1)	Refer to Sec 8, [3.3] and Sec 8, [3.4]. In order to prevent damages to the electronic components of the battery system, the electronic components can be disconnected during the high voltage test.

5.3 Testing and inspection after installation on board

5.3.1 (1/1/2022)

After installation, and after any important repair or alteration which may affect the safety of the arrangement, following a check of compliance with the plans, the battery system is to be subjected to tests and inspections, to the satisfaction of the Surveyor in charge.

5.3.2 (1/1/2022)

Performance tests are to be carried out on the battery system; the test program is to include functional tests as per Tab 4 and further tests, if any, resulting from the Risk Assessment.

- tests on all the equipment affecting the battery system (e.g. instrumentation, sensors, etc.),
- recommended test intervals to reduce the probability of failure,
- recommended survey plan (annual and renewal surveys),
- functional tests of control, monitoring, safety and alarm system,
- verification of the State of Health (SOH),
- instructions for Software Maintenance.

5.4 Plans to be kept on board

5.4.1 (1/1/2022)

An operation manual is to be kept on board which includes at least:

- charging procedure,
- normal operation procedures, including instructions for the safe connection/disconnection of batteries,
- emergency operation procedures,
- estimated battery deterioration (ageing) rate curves, considering modes of operation.

5.4.2 (1/1/2022)

A maintenance manual for systematic maintenance and functional testing is to be kept on board which includes at least:

Table 4 (1/1/2022)

No.	Test/verification
1	Insulation resistance test as per Sec 15, [3.3]
2	Test of the functionality of the battery system and BMS and its auxiliaries, including alarms, and safety functions, emergency stop, including simulation of changes in parameters and simulation of sensor failure and of communication failure (e.g. with battery charger)
3	Test of the functionality of the auxiliary services in the battery space (e.g. ventilation, liquid cooling, gas detection, fire detection, leakage detection)
4	Verification of proper calculation and indication of SOC and SOH (when required per [3.2.4]) (1)
(1)	Tests for the verification of the battery SOH are to be carried out (e.g. complete charge/discharge cycle or other methods as per Manufacturer's indications).

No.	Test/verification
5	Verification of correct regulation of charging and discharging currents
6	Verification of the functionality of the EMS (when required per [2.1.3])
7	Test of the independent disconnecting device as per [2.3.3]
(1) Tests for the verification of the battery SOH are to be carried out (e.g. complete charge/discharge cycle or other methods as per Manufacturer's indications).	

APPENDIX 3 FUEL CELL POWERED SHIPS

1 General

1.1 Scope

1.1.1 Application (1/1/2023)

The provisions of this Appendix apply to the arrangement, installation, control, monitoring and safety systems of ships using fuel cell power installations. These Rules are applicable to installations with several different configurations of fuel cell power installations. Since the fuel cell is a novel technology under continuous development, additional requirements to those specified in these Rules may be required by Tasneef on a case-by-case basis depending on the design principles of the fuel cell in subject. Where the fuel cell power installations consist of the fuel cell power systems which are enclosed in modules, the Tasneef "Rules for the Type Approval of Fuel Cell Power Modules" apply in conjunction with this Appendix.

1.1.2 Acceptance by the flag Administration (1/1/2023)

The use of fuel cells on ships requires acceptance by the Administration of the State whose flag the ship is entitled to fly.

1.1.3 MSC.1/Circ.1647 requirements and the Society's rules (1/1/2023)

For fuel cell powered ships, the requirements of the IMO Interim Guidelines for the Safety of Ships using Fuel Cell Power Installations set out in the annex of IMO circular MSC.1/Circ.1647 (hereinafter named "MSC.1/Circ.1647") are to be applied as class requirements as specified and with the deviations given in this Appendix.

For the scope of classification, when reference is made to paragraphs of MSC.1/Circ.1647 where the wording "Administration" is used, it is to be regarded as referring to the "Society".

In general, this Appendix applies to fuel cell power installations and to their interfaces with the other ship systems. Unless otherwise specified, the machinery, equipment and systems of fuel cell powered ships are also to comply with the requirements given in Part C.

The fuel cell power installations designed to use low-flashpoints fuels as primary fuel (e.g. LNG, LPG, NH₃, methyl/ethyl alcohol, hydrogen) are additionally to comply with the following requirements, as applicable:

- Ch 1, App 7 (LNG or CNG Fuelled Ships)
- Ch 1, App 13 (LPG or NH₃ Fuelled Ships)
- Ch 1, App 14 (Hydrogen Fuelled Ships)
- Ch 1, App 15 (Methyl/Ethyl Alcohol Fuelled Ships).

The electrical equipment needed for the conditioning of the electrical output from the fuel cell power installation such

as e-filters, inverters, converters and transformers are to comply with Sec 5 and Sec 6. The reforming equipment as well auxiliary systems are to comply with Ch 1, Sec 3 and Ch 1, Sec 10.

1.1.4 MSC.1/Circ.1647 requirements not within the scope of classification (1/1/2023)

The following requirements of MSC.1/Circ.1647 are not within the scope of classification:

- Section 3 - Fire Safety

These requirements are applied by the Society when acting on behalf of the flag Administration, within the scope of delegation (see [1.1.6]).

1.1.5 Correspondence of the MSC.1/Circ.1647 with the Rules (1/1/2023)

All the requirements of this Appendix are cross referenced to the applicable paragraphs of MSC.1/Circ.1647, as appropriate.

1.1.6 Statutory certificates (1/1/2023)

The responsibility for interpretation of the MSC.1/Circ.1647 requirements for the purpose of issuing statutory certificates for fuel cell powered ships lies with the Administration of the State whose flag the ship is entitled to fly.

Whenever the Society is authorized by an Administration to issue on its behalf the statutory certificates for fuel cell powered ships, or where the Society is authorized to carry out investigations and surveys on behalf of an Administration on the basis of which the statutory certificates for fuel cell powered ships will be issued by the Administration, or where the Society is requested to certify compliance with MSC.1/Circ.1647, the full compliance with the requirements of MSC.1/Circ.1647, including the fire safety requirements mentioned in [1.1.4], will be granted by the Society, subject to [1.1.2].

1.1.7 FUEL CELL POWERED SHIP additional class notation (1/1/2023)

The **FUEL CELL POWERED SHIP** additional class notation is assigned to ships where fuel cells are installed to supply essential or not-essential services, in compliance with the design and constructional requirements of this Appendix, as follows:

- **FUEL CELL POWERED SHIP (E)** when fuel cell is used to power at least one of the essential services defined in Sec 1, [3.2.1] and is necessary to ensure the compliance of the main source of electrical power to the requirements in Sec 3, [2.2.3]
- **FUEL CELL POWERED SHIP (NE)** when fuel cell is used to power only services not falling under the definition of essential services in Sec 1, [3.2.1].

1.2 Documentation to be submitted

1.2.1 (1/1/2023)

Tab 1 lists the plans, information, analysis, etc. which are to be submitted in addition to the information required in the

other Parts of the Rules, for the portion of the ship not involved in fuel cell power installations.

The Society reserves the right to request the submission of additional documents in the case of non-conventional design or if it is deemed necessary for the evaluation of the system, equipment or components.

Table 1 : Documents to be submitted (1/1/2023)

No.	I/A (1)	Document
1	I	Technical specification of the fuel cell power installation, including technical data as power output parameters including min./max. design voltage and current, information about min/max temperature/pressure/rate of process air/cooling water/ventilation.
2	I	List of mechanical and electrical components which are part of the fuel cell power installation with specification of the pumps, compressors and fans.
3	A	P&I diagrams of systems conveying fuel (primary and reformed type), exhaust air/gas, cooling media, process air, technical water, ventilation, inerting and of other systems in the fuel cell power installation.
4	I	Description of thermal insulation and heat tracing, if any.
5	A	Construction details with strength analysis of fuel cell power installation frame and foundation, if any.
6	A	Construction drawings of all components of the reforming equipment considered as pressure vessel e.g. burner, reformer, heat exchangers.
7	I	Functional description of the fuel cell power installation including at least its design, safety principles, ventilation and gas detection concept, auxiliary systems arrangement (e.g. cooling medium, process air, ventilation, venting, process water, inert gas, as applicable).
8	A	Block diagram of the safety, control and monitoring system of the fuel cell power installation.
9	A	Wiring diagrams of power supply and automation system of the fuel cell power installation.
10	I	List of controlled and monitored parameters and cause and effect matrix with normal/emergency shut-down functions.
11	A	Hazardous zones categorization study with calculation according to IEC 60079-10 (using CFD simulations or empirical formula) and list of EX equipment with relevant EX certificates, as applicable.
12	A	Service profile description of the fuel cell power installations, highlighting if the fuel cell power generation is used for essential or non-essential ship services.
13	I	A FMEA according to the Tasneef "Guide for Failure mode and Effect Analysis" or other equivalent methods for the fuel cell power installation.
14	I	Lifecycle operational, maintenance and inspection manual of the fuel cell power installation.
15	I	Testing reports or type approval reference of the fuel cell power installation components such as fuel cell stacks, reforming equipment according to applicable international recognized standards.
(1) A = to be submitted for approval I = to be submitted for information		

1.3 Definitions

MSC.1/Circ.1647 REFERENCE: para. 1.4

1.3.1 (1/1/2023)

The terms used in this Appendix have the meanings defined in MSC.1/Circ.1647, para. 1.4 and in the Tasneef "Rules for the Type Approval of Fuel Cell Power Modules".

Terms not defined have the same meaning as in SOLAS chapter II-2 and the IGF Code.

1.3.2 (1/1/2023)

Certified safe type: means electrical equipment that is certified safe by the relevant recognized authorities for operation in a flammable atmosphere based on a recognized standard.

Note 1: Refer to IEC 60079 series, Explosive atmospheres and IEC 60092-502:1999 Electrical Installations in Ships - Tankers - Special Features.

1.3.3 (1/1/2023)

Fuel cell power module: is the fuel cell power system or parts of fuel cell power system and relevant enclosure.

1.3.4 (1/1/2023)

Fuel cell module: is the assembly incorporating one or more fuel cell stacks and auxiliary systems.

1.3.5 (1/1/2023)

Fuel supply module: is the enclosure containing the fuel reforming and fuel conditioning equipment.

1.3.6 (1/1/2023)

Service profile: is a description of the use of the fuel cell for the power supply to on-board systems considering the operational profile of the ship (navigation, maneuvering and port stay).

2 Goal and functional requirements

MSC.1/Circ.1647 REFERENCE: para. 1.2 and 1.3

2.1 Goal

2.1.1 (1/1/2023)

The goal of this Appendix is to provide for safe and reliable delivery of electrical and/or thermal energy through the use of fuel cell technology.

2.2 Functional requirements

2.2.1 (1/1/2023)

The safety, reliability and dependability of the systems is to be equivalent to that achieved with new and comparable conventional oil-fuelled main and auxiliary machinery installations, regardless of the specific fuel cell type and fuel.

A FMEA consistent with the Tasneef "Guide for Failure Mode and Effect Analysis" is to be carried out for the whole fuel cell power installation to check the potential existence of failure modes that can jeopardize the ship's safety. The results of the FMEA are then to be used to establish a trial program.

2.2.2 (1/1/2023)

The probability and consequences of fuel-related hazards are to be limited to a minimum through arrangement and system design, such as ventilation, detection and safety actions. In the event of gas leakage or failure of the risk reducing measures, necessary safety actions are to be initiated.

2.2.3 (1/1/2023)

The design philosophy is to ensure that risk reducing measures and safety actions for the fuel cell power installation do not lead to an unacceptable loss of power.

2.2.4 (1/1/2023)

Hazardous areas are to be restricted, as far as practicable, to minimize the potential risks that might affect the safety of the ship, persons on board, and equipment.

2.2.5 (1/1/2023)

Equipment installed in hazardous areas are to be minimized to that required for operational purposes and are to be suitably and appropriately certified.

2.2.6 (1/1/2023)

Unintended accumulation of explosive, flammable or toxic gas concentrations are to be prevented.

2.2.7 (1/1/2023)

System components are to be protected against external damages.

2.2.8 (1/1/2023)

Sources of ignition in hazardous areas are to be minimized to reduce the probability of explosions.

2.2.9 (1/1/2023)

Piping systems and overpressure relief arrangements that are of suitable design, construction and installation for their intended application are to be provided.

2.2.10 (1/1/2023)

Machinery, systems and components are to be designed, constructed, installed, operated, maintained and protected to ensure safe and reliable operation.

2.2.11 (1/1/2023)

Fuel cell spaces are to be arranged and located such that a fire or explosion in either will not lead to an unacceptable loss of power or render equipment in other compartments inoperable.

2.2.12 (1/1/2023)

Suitable control, alarm, monitoring and shutdown systems are to be provided to ensure safe and reliable operation.

2.2.13 (1/1/2023)

Fixed leakage detection suitable for all spaces and areas concerned is to be arranged.

2.2.14 (1/1/2023)

Fire detection, protection and extinction measures appropriate to the hazards concerned are to be provided.

2.2.15 (1/1/2023)

Commissioning, trials and maintenance of fuel systems and gas utilization machinery are to satisfy the goal in terms of safety, availability and reliability.

2.2.16 (1/1/2023)

The technical documentation is to permit an assessment of the compliance of the system and its components with the applicable rules, guidelines, design standards used and the principles related to safety, availability, maintainability and reliability.

2.2.17 (1/1/2023)

A single failure in a technical system or component is not to lead to an unsafe or unreliable situation.

The fuel cell power installations that:

- are used to power at least one essential service as defined in Sec 1, [3.2.1] , and
- are necessary to ensure the compliance of the main source of electrical power to the requirements in Sec 3, [2.2.3]

are to be specifically considered in terms of reliability, availability and redundancy.

2.2.18 (1/1/2023)

Safe access is to be provided for operation, inspection and maintenance.

Figure 1 : Example of typical configuration of Fuel cell power module (1/1/2023)

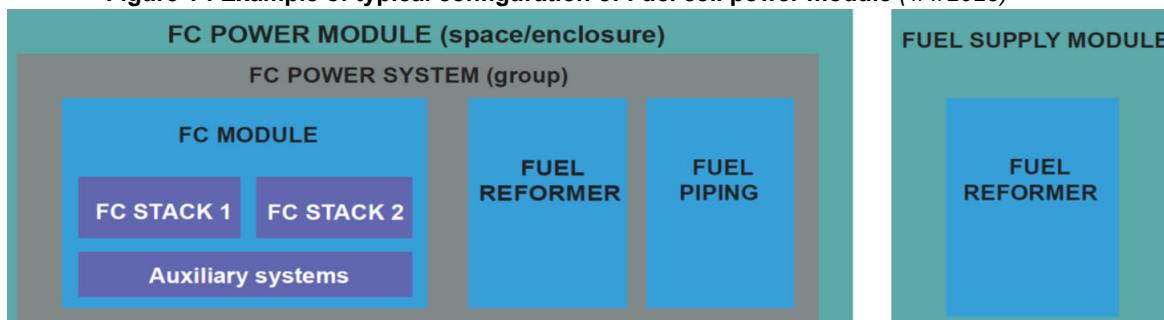

3 Alternative design

MSC.1/Circ.1647 REFERENCE: para. 1.5

3.1

3.1.1 (1/1/2023)

Appliances and arrangements of fuel cell power systems may deviate from those set out in this Appendix provided that they meet the intent of the goal and functional requirements concerned and provide an equivalent level of safety of the relevant paragraphs.

3.1.2 (1/1/2023)

The equivalence of the alternative design is to be demonstrated as specified in SOLAS regulation II-1/55, and approved by the Society. However, the Society will not allow operational methods or procedures as an alternative to a particular fitting, material, appliance, apparatus, item of equipment, or type thereof which is prescribed by this Appendix.

4 Design principles for fuel cell power installations

MSC.1/Circ.1647 REFERENCE: para. 2

4.1 Fuel cell spaces

4.1.1 (1/1/2023)

The requirements in MSC.1/Circ.1647 para. 2.1 apply.

4.2 Arrangement and access

4.2.1 (1/1/2023)

The requirements in MSC.1/Circ.1647 para. 2.2 apply.

4.3 Atmospheric control of fuel cell spaces

4.3.1 General (1/1/2023)

The requirements in MSC.1/Circ.1647 para. 2.3.1 apply.

4.3.2 Ventilation of fuel cell spaces (1/1/2023)

The requirements in MSC.1/Circ.1647 para. 2.3.2 apply.

When applying the requirements in MSC.1/Circ.1647 para. 2.3.2.3, reference is to be made to IEC 60079-10 standard.

4.3.3 Inerting of fuel cell spaces for fire protection purposes (1/1/2023)

The requirements in MSC.1/Circ.1647 para. 2.3.3 apply.

4.4 Materials

4.4.1 (1/1/2023)

The requirements in MSC.1/Circ.1647 para. 2.4 apply.

4.4.2 (1/1/2023)

The use of plastic materials for piping and pressure vessels is in general not allowed. Specific application may be evaluated on case-by-case basis.

4.5 Piping arrangement for fuel cell power system

4.5.1 (1/1/2023)

The requirements in MSC.1/Circ.1647 para. 2.5 apply.

4.5.2 (1/1/2023)

Where the fuel cell stacks are subject to specific air quality requirements (e.g., limits on dust, humidity, salinity, temperature), arrangements for air conditioning, air drying and air filtering are to be fitted and the air quality parameters are to be monitored.

4.5.3 (1/1/2023)

Where the primary fuel is subject to specific quality requirements (e.g., maximum Sulphur content) not to impair the performances of the fuel cell power system, arrangements for fuel conditioning system are to be fitted.

4.5.4 (1/1/2023)

If enclosed fuel supply modules and enclosed fuel cell modules are installed, they are to be fitted with sampling point connections for detecting explosive atmosphere by means of portable equipment.

4.5.5 (1/1/2023)

Where the pressure vessels and the piping in the fuel cell power module may be subject to overpressure, they are to be suitably protected by pressure relief arrangements. The discharge of possible hazardous gases is to be routed to open air.

4.6 Exhaust gas and exhaust air

4.6.1 (1/1/2023)

Exhaust gases and exhaust air from the fuel cell power systems should not be combined with any ventilation and should be led to a safe location in the open air.

4.6.2 (1/1/2023)

The arrangement of the process air treatment system is to be subject to the risk assessment as required in [6.3].

5 Fire safety

MSC.1/Circ.1647 REFERENCE: para. 3

5.1

5.1.1 (1/1/2023)

This paragraph is void, as the provisions of MSC.1/Circ.1647 para. 3 are not within the scope of classification.

These provisions are applied by the Society when acting on behalf of the flag Administration, within the scope of delegation (see [1.1.6]).

6 Electrical systems

MSC.1/Circ.1647 REFERENCE: para. 4

6.1 General provisions on electrical systems

6.1.1 (1/1/2023)

The requirements in MSC.1/Circ.1647 para. 4.1 apply.

6.1.2 (1/1/2023)

For the casing of the fuel cell stack to be mounted in the fuel cell space, a minimum enclosure notation of IP54 is required to protect against:

- ingress of dust in sufficient quantity to interfere with satisfactory operation of the fuel cell; and
- water splashed against the fuel cell stack from any direction.

6.1.3 (1/1/2023)

The equipment and installations in hazardous areas are to comply with recognized international standards including but not limited to the following:

- IEC 60079-0 General requirements
- IEC 60079-1 Flameproof enclosure 'Ex d'
- IEC 60079-7 Increased safety 'Ex e'
- IEC 60079-11 Intrinsic safety 'Ex i'
- IEC 60079-14 Installations
- IEC 60079-17 Electrical Installations inspection and maintenance
- IEC 60079-18 Molded encapsulation 'Ex m'
- IEC 60079-25 Intrinsically safe systems
- IEC 60079-29 Gas detection

The equipment is to be properly EX certified considering the hazardous zone categorization defined by manufacturer according to IEC 60079-10 or according to [6.2].

6.1.4 (1/1/2023)

Earthing and bonding are to be arranged according to recognized international standards.

6.2 Area classification

6.2.1 General (1/1/2023)

The requirements in MSC.1/Circ.1647 para. 4.2.1 apply.

6.2.2 Hazardous areas zone 0 (1/1/2023)

The requirements in MSC.1/Circ.1647 para. 4.2.2 apply.

6.2.3 Hazardous areas zone 1 (1/1/2023)

The requirements in MSC.1/Circ.1647 para. 4.2.3 apply.

6.2.4 Hazardous areas zone 2 (1/1/2023)

The requirements in MSC.1/Circ.1647 para. 4.2.4 apply.

6.2.5 Ventilation ducts (1/1/2023)

The requirements in MSC.1/Circ.1647 para. 4.2.5 apply.

6.3 Risk assessment

6.3.1 (1/1/2023)

The requirements in MSC.1/Circ.1647 para. 4.3 apply.

6.3.2 (1/1/2023)

Guidance on risk assessment techniques can be found in the Tasneef "Guide for Risk Analysis".

6.3.3 (1/1/2023)

The assumptions for the risk assessment are to be agreed by a team of experts acceptable to the Society. It may include a representative of Class, Flag Administration, owner, builder or designer, and consultants having the necessary knowledge and experience in safety, design and/or operation as necessary for the specific evaluation at hand. Other members may include marine surveyors, ship operators, safety engineers, equipment manufacturers, human factors experts, naval architects and marine engineers, according to the problem under scope.

6.3.4 (1/1/2023)

The risk assessment can be qualitative or quantitative and is to cover the following aspects:

- Accidental release and dispersion (hydrogen leakages due to tank and piping rupture and permeability, hydrogen dilution in enclosed space, hydrogen effects on material e.g. embrittlement or permeation)
- Ignition (spontaneous ignition of hydrogen during sudden release, minimum energy for ignition)
- Deflagration and detonation (hydrogen explosion hazards)
- Fires (jet fire, radiative heat fluxes, fire resistance of hydrogen system)
- Impact on people, asset and environment (severity of hydrogen incidents)
- Mitigation techniques (detection method, barriers, ventilation level)
- Emergency operation (strategy control of incident)
- Oxygen enrichment due to cryogenic hydrogen temperature.

6.3.5 (1/1/2023)

The risk assessment is to follow the steps outlined below.

- The team of experts is to conduct a Hazard Identification (HAZID) to agree on the scenarios to be subjected to the risk assessment, and on the assumptions regarding the most critical events (typically, connection failures causing an hydrogen or primary fuel release) considering also available internationally recognized standard (e.g. ISO/TR 15916) for the identification of hazards and risks.
- Reasonable assumptions on the extent of connection failures or other selected events and the process parameters of the hydrogen and primary fuel are to be made by the team of experts, preferably on the basis of

statistics available in the public domain or provided and documented by stakeholders.

- c) Reasonable assumptions on the operation of ventilation system are to be made according to layout and procedures of the affected space.
- d) In order to verify that the hydrogen and primary fuel release will not create flammable concentrations and to demonstrate the drip tray capacity for a liquid leakage, a specific simulation is to be set up, aimed at evaluating the maximum amount of hydrogen spilled and its cloud, the evaporation rate and the possibility to fully accommodate the liquid leakage in the drip tray. The dispersion of vapors resulting from hydrogen evaporation in the affected space is also to be ascertained in respect of explosive atmosphere.
- e) The simulation is to be conducted by commercially available and validated tools (typically, by CFD tools). It is to focus on the calculation of the amount of hydrogen or primary fuel spilled before the stop of hydrogen and primary fuel flow. Other calculation methods (e.g. empirical formulas based on literature) will be subject to special consideration.
- f) Reasonable assumptions are to be made by the expert team regarding detection time, hydrogen and primary fuel flow stop time and human reaction time, in case operators are credited in the emergency.
- g) If the simulation demonstrates that the drip tray cannot accommodate the liquid spill, mitigating measures are to be provided and subjected to the same simulation process, to appreciate the risk reduction.

7 Control, monitoring and safety systems

MSC.1/Circ.1647 REFERENCE: para. 5

7.1 General provisions on control, monitoring and safety systems

7.1.1 (1/1/2023)

The requirements in MSC.1/Circ.1647 para. 5.1 apply.

7.1.2 (1/1/2023)

The fuel cell power installation is to be provided with a safety system with the following characteristics:

- "fail safe" design, so that any failure of the safety system cannot result in an unsafe status for the fuel cell module
- independent from control and alarm system
- compliant with the requirements in Ch 3, Sec 2, [7].

7.2 Gas or vapour detection

7.2.1 (1/1/2023)

The requirements in MSC.1/Circ.1647 para. 5.2 apply.

7.3 Ventilation performance

7.3.1 (1/1/2023)

The requirements in MSC.1/Circ.1647 para. 5.3 apply.

7.4 Bilge wells

7.4.1 (1/1/2023)

The requirements in MSC.1/Circ.1647 para. 5.4 apply.

7.5 Manual emergency shutdown

7.5.1 (1/1/2023)

The requirements in MSC.1/Circ.1647 para. 5.5 apply.

7.6 Actions of the alarm system and safety system

7.6.1 (1/1/2023)

The requirements in MSC.1/Circ.1647 para. 5.6 apply.

7.7 Alarms

7.7.1 (1/1/2023)

The requirements in MSC.1/Circ.1647 para. 5.7 apply.

7.8 Safety actions

7.8.1 (1/1/2023)

The requirements in MSC.1/Circ.1647 para. 5.8 apply.

8 Tests on board

8.1 Functioning Tests

8.1.1 (1/1/2023)

Where the fuel cell power installation provides power to the electric propulsion system, it is to be verified that the ship has adequate management system of propulsion power in all sailing conditions including maneuvering, according to Ch 1, Sec 16, [3.7].

8.1.2 (1/1/2023)

The fuel cell space ventilation system is to be tested prior to the commencement of the sea trials with the verification of the following items:

- air flow of all fans according to the required capacity as per hazardous zone categorization
- alarms and/or automatic shutdown in case of loss or reduction of required ventilation rate
- gas tightness of all flexible connections of fans to duct
- local and remote functioning test of dampers.

8.1.3 (1/1/2023)

The fuel cell space inerting system is to be tested prior the commencement of the sea trials with the verification of the following items:

- functioning of inert gas generator or inert gas storage means (e.g. bottles)
- purging of fuel cell space piping conveying hydrogen and primary fuel.

8.1.4 (1/1/2023)

The fuel cell space gas detection system is to be tested according to international recognized standard prior the commencement of the sea trials.

8.1.5 (1/1/2023)

The following fuel cell power system items are to be tested:

- all automatic safety shutdowns

- emergency safety shutdown (manual ESD) at maximum power load
- protective devices (e.g. safety and automatic shut-off valves)
- measurements systems (e.g. level indicators, temperature measurement devices, pressure gauges).

8.1.6 (1/1/2023)

The performance test for the fuel cell power system is to be carried out considering the service profile and is to demonstrate that the fuel cell generated power will meet the performance requirements to be previously agreed with Tasneef. During all testing the ambient conditions (air temperature, air pressure and humidity) are to be recorded. Moreover, as a minimum, the following fuel cell power module data are to be measured, recorded and compared with the targeted values:

- Nominal Load Point [A]
- Total Voltage [V]
- Total Current [A]
- Total Power [kW]
- Primary Fuel Consumption [kg/h]
- Fuel Inlet Pressure [bar]
- Fuel Inlet Temperature [C°]
- Cooling Water Inlet Temperature [C°]
- Cooling Water Outlet Temperature [C°]
- Ventilation air flow
- Process air flow

The typical polarization curve (cell voltage vs current) of the fuel cell power system, as created during factory acceptance test, is to be made available on board for prompt reference.

8.1.7 (1/1/2023)

The performance tests are to be carried out considering the following conditions:

- start up, ramp up, rump down and automatic shutdown of the fuel cell power system
- load variations and load shedding as per service profile
- interactions with other sources of power, including change-over with the emergency power source.

8.2 Hot spot verification

8.2.1 (1/1/2023)

Thermal imaging scanning of equipment where hot surfaces may be expected is to be carried out within the fuel cell power installation under steady and normal operating conditions, according to Ch 1, Sec 2, [6.10.9]. The requirements in Ch 1, Sec 1, [3.7.1] apply.

9 Material Test, Workshop inspections and testing

9.1 General principles

9.1.1 (1/1/2023)

The provisions in this section are to be used in conjunction with the applicable requirements on materials and testing in

other parts of these Rules and Tasneef "Rules for Testing and Certification of Marine Materials and Equipment".

9.1.2 (1/1/2023)

Inspection and testing of fuel piping systems are to comply with Ch 1, Sec 10, [21].

9.1.3 (1/1/2023)

All pressure vessels and piping conveying the primary fuel and the reformed fuel belong to Class I piping systems according to Ch 1, Sec 3 and Ch 1, Sec 10.

Outer pipes of double wall fuel piping arrangements are to be considered to belong to Class II piping systems.

9.1.4 (1/1/2023)

The venting and ventilation lines conveying the exhaust air from fuel cell stack cathode side and the exhaust gas from reforming equipment or from fuel cell stack anode side are to be connected with butt welded joints as far as practicable. Alternatively, the use of type approved mechanical joints or other type of connections may be evaluated on case-by-case basis. These lines, if categorized as hazardous, are to be considered to belong to Class I piping systems.

9.2 Type approval

9.2.1 (1/1/2023)

Fuel cell modules are to be provided with type approval certificate according to Tasneef "Rules for the Type Approval of Fuel Cell Power modules".

9.2.2 (1/1/2023)

The piping components such as flexible hoses, mechanical joints and plastic pipes are to be provided with type approval certificates according to Ch 1, Sec 10.

9.2.3 (1/1/2023)

The electronic and electrical components (e.g. sensors, cables, panels) are to be provided with type approval certificates according to Sec 15, [2].

9.3 Production testing

9.3.1 (1/1/2023)

The fuel cell power system is subject to functioning test at workshop under Tasneef surveyor's attendance on the basis of previously agreed test program taking into consideration the service profile and the availability of the type approval certificates for the fuel cell modules.

9.3.2 (1/1/2023)

Pressure vessels belonging to the fuel cell power system are subject to testing according to Ch 1, Sec 3, [7].

9.3.3 (1/1/2023)

The electrical installations for the fuel cell power conditioning are subject to testing according to Sec 15.

9.3.4 (1/1/2023)

The automation system components are subject to testing according to Ch 3, Sec 8.

Part C
Machinery, Systems and Fire Protection

Chapter 3
AUTOMATION

- SECTION 1 GENERAL REQUIREMENTS**
- SECTION 2 DESIGN REQUIREMENTS**
- SECTION 3 COMPUTER BASED SYSTEMS**
- SECTION 4 CYBER RESILIENCE OF SHIPS**
- SECTION 5 CYBER RESILIENCE OF ON-BOARD SYSTEMS AND EQUIPMENT**
- SECTION 6 CONSTRUCTIONAL REQUIREMENTS**
- SECTION 7 INSTALLATION REQUIREMENTS**
- SECTION 8 TESTING**

SECTION 1

GENERAL REQUIREMENTS

1 General

1.1 Field of application

1.1.1 The following requirements apply to automation systems, installed on all ships, intended for essential services as defined in Ch 2, Sec 1. They also apply to systems required in Chapter 1 and Chapter 2, installed on all ships.

1.1.2 This chapter is intended to avoid that failures or malfunctions of automation systems associated with essential and non-essential services cause danger to other essential services.

1.1.3 Requirements for unattended machinery spaces and for additional notations are specified in Part F.

1.1.4 (1/7/2024)

Requirements for Computer-based systems and Cyber resilience of ships are specified in Sec 3, Sec 4 and Sec 5.

1.2 Regulations and standards

1.2.1 The regulations and standards applicable are those defined in Ch 2, Sec 1.

1.3 Definitions

1.3.1 Unless otherwise stated, the terms used in this chapter have the definitions laid down in Ch 2, Sec 1 or in the IEC standards. The following definitions also apply:

- Alarm indicator is an indicator which gives a visible and/or audible warning upon the appearance of one or more faults to advise the operator that his attention is required.
- Alarm system is a system intended to give a signal in the event of abnormal running condition.
- Application software is a software performing tasks specific to the actual configuration of the programmable electronic system and supported by the basic software.
- Automatic control is the control of an operation without direct or indirect human intervention, in response to the occurrence of predetermined conditions.
- Automation systems are systems including control systems and monitoring systems.
- Basic software is the minimum software, which includes firmware and middleware, required to support the application software.
- Cold standby system is a duplicated system with a manual commutation or manual replacement of cards which are live and non-operational. The duplicated system is to be able to achieve the operation of the main system with identical performance, and be operational within 10 minutes.
- Programmable electronic system is a system of one or more computers, associated software, peripherals and interfaces, and the computer network with its protocol.
- Control station is a group of control and monitoring devices by means of which an operator can control and verify the performance of equipment.
- Control system is a system by which an intentional action is exerted on an apparatus to attain given purposes.
- Expert system is an intelligent knowledge-based system that is designed to solve a problem with information that has been compiled using some form of human expertise.
- Fail safe is a design property of an item in which the specified failure mode is predominantly in a safe direction with regard to the safety of the ship, as a primary concern.
- Full redundant is used to describe an automation system comprising two (identical or non-identical) independent systems which perform the same function and operate simultaneously.
- Hot standby system is used to describe an automation system comprising two (identical or non-identical) independent systems which perform the same function, one of which is in operation while the other is on standby with an automatic change-over switch.
- Instrumentation is a sensor or monitoring element.
- Integrated system is a system consisting of two or more subsystems having independent functions connected by a data transmission network and operated from one or more workstations.
- Local control is control of an operation at a point on or adjacent to the controlled switching device.
- Manual control is control of an operation acting on final control devices either directly or indirectly with the aid of electrical, hydraulic or mechanical power.
- Monitoring system is a system designed to observe the correct operation of the equipment by detecting incorrect functioning (measure of variables compared with specified value).
- Safety system is a system intended to limit the consequence of failure and is activated automatically when an abnormal condition appears.
- Software is the program, procedures and associated documentation pertaining to the operation of the computer system.
- Redundancy is the existence of more than one means for performing a required function.
- Remote control is the control from a distance of apparatus by means of an electrical or other link.

1.4 General

1.4.1 The automation systems and components, as indicated in Ch 2, Sec 15, [2], are to be chosen from among the list of type approved products.

They are to be approved on the basis of the applicable requirements of these Rules and in particular those stated in this Chapter.

Case by case approval may also be granted at the discretion of the Society, based on submission of adequate documentation and subject to the satisfactory outcome of any required tests.

1.4.2 *Main and auxiliary machinery essential for the propulsion, control and safety of the ship shall be provided with effective means for its operation and control.*

1.4.3 Control, alarm and safety systems are to be based on the fail-to-safety principle.

1.4.4 Failure of automation systems is to generate an alarm.

1.4.5 Detailed indication, alarm and safety requirements regarding automation systems for individual machinery and installations are to be found in Chapter 1.

2 Documentation

2.1 General

2.1.1 Before the actual construction is commenced, the Manufacturer, Designer or Shipbuilder is to submit to the Society the documents (plans, diagrams, specifications and calculations) requested in this Section.

The list of documents requested is to be intended as guidance for the complete set of information to be submitted, rather than an actual list of titles.

The Society reserves the right to request the submission of additional documents in the case of non-conventional design or if it is deemed necessary for the evaluation of the system, equipment or components.

Plans are to include all the data necessary for their interpretation, verification and approval.

Unless otherwise agreed with the Society, documents for approval are to be sent in triplicate if submitted by the Shipyard and in four copies if submitted by the equipment supplier. Documents requested for information are to be sent in duplicate.

In any case, the Society reserves the rights to require additional copies, when deemed necessary.

2.2 Documents to be submitted

2.2.1 The documents listed in Tab 1 are to be submitted.

Table 1 : Documentation to be submitted

No.	I/A (1)	Documentation
1	A	The general specification for the automation of the ship
2	A	The detailed specification of the essential service systems
3	A	The list of components used in the automation circuits, and references (Manufacturer, type, etc.)
4	I	Instruction manuals
5	I	Test procedures for control, alarm and safety systems
6	A	A general diagram showing the monitoring and/or control positions for the various installations, with an indication of the means of access and the means of communication between the positions as well as with the engineers
7	A	The diagrams of the supply circuits of automation systems, identifying the power source
8	A	The list of monitored parameters for alarm/monitoring and safety systems
9	A	Diagram of the engineers' alarm system
(1) A = to be submitted for approval; I = to be submitted for information.		

Table 2 : Documentation to be submitted for programmable electronic systems (1/1/2008)

No.	I/A (1)	Documentation (2)
1	A	System block diagram, showing the arrangement of individual parts, input and output devices and interconnections
2	A	Wiring connection diagrams, including details of electrical power supplies, and of input and output devices
3	A	System functional description
(1) A = to be submitted for approval; I = to be submitted for information.		
(2) See as guidance IEC 60092-504 clause 10.11		

No.	I/A (1)	Documentation (2)
4	I	Software system description and documentation
5	I	User interface description
6	I	Test programs
<p>(1) A = to be submitted for approval; I = to be submitted for information.</p> <p>(2) See as guidance IEC 60092-504 clause 10.11</p>		

2.3 Documents for programmable electronic system

2.3.1 General

For programmable electronic systems, the documents listed in Tab 2 are to be submitted.

2.3.2 System description, computer software

This documentation is to contain:

- a list of all main software modules installed per hardware unit with names and version numbers
- a description of all main software which is to include at least:
 - a description of basic software installed per hardware unit, including communication software, when applicable
 - a description of application software.

2.3.3 Description of computer hardware

The documentation to be submitted is to include:

- hardware information of importance for the application and a list of documents that apply to the system.
- the supply circuit diagram
- a description of hardware and software tools for equipment configuration
- the information to activate the system
- general information for trouble shooting and repair when the system is in operation.

2.3.4 System reliability analysis

The documentation to be submitted is to demonstrate the reliability of the system by means of appropriate analysis such as:

- a failure mode analysis describing the effects due to failures leading to the destruction of the automation system. In addition, this documentation is to show the consequences on other systems, if any. This analysis is appraised in accordance with the IEC Publication 60812, or a recognised standard
- test report /life test
- MTBF calculation (Mean Time Between Failure)
- any other documentation demonstrating the reliability of the system.

2.3.5 User interface description

The documentation is to contain:

- a description of the functions allocated to each operator interface (keyboard/screen or equivalent)
- a description of individual screen views (schematics, colour photos, etc.)
- a description of how menus are operated (tree presentation)
- an operator manual providing necessary information for installation and use.

2.3.6 Test programs

The following test programs are to be submitted:

- software module/unit test
- software integration test
- system validation test
- on-board test.

Each test program is to include:

- a description of each test item
- a description of the acceptance criteria for each test.

2.4 Documents for type approval of equipment

2.4.1 Documents to be submitted for type approval of equipment are listed hereafter:

- a request for type approval from the manufacturer or his authorized representative
- the technical specification and drawings depicting the system, its components, characteristics, working principle, installation and conditions of use and, when there is a programmable electronic system, the documents listed in Tab 2
- any test reports previously prepared by specialised laboratories.

3 Environmental and supply conditions

3.1 General

3.1.1 General

The automation system is to operate correctly when the power supply is within the range specified in Sec 2.

3.1.2 Environmental conditions

The automation system is to be designed to operate satisfactorily in the environment in which it is located. The environmental conditions are described in Ch 2, Sec 2.

3.1.3 Failure behaviour

The automation system is to have non-critical behaviour in the event of power supply failure, faults or restoration of operating condition following a fault. If a redundant power supply is used, it must be taken from an independent source.

3.2 Power supply conditions

3.2.1 Electrical power supply

The conditions of power supply to be considered are defined in Ch 2, Sec 2.

3.2.2 Pneumatic power supply

For pneumatic equipment, the operational characteristics are to be maintained under permanent supply pressure variations of $\pm 20\%$ of the rated pressure.

Detailed requirements are given in Ch 1, Sec 10.

3.2.3 Hydraulic power supply

For hydraulic equipment, the operational characteristics are to be maintained under permanent supply pressure variations of $\pm 20\%$ of the rated pressure.

Detailed requirements are given in Ch 1, Sec 10.

4 Materials and construction

4.1 General

4.1.1 The choice of materials and components is to be made according to the environmental and operating conditions in order to maintain the proper function of the equipment.

4.1.2 The design and construction of the automation equipment is to take into account the environmental and operating conditions in order to maintain the proper function of the equipment.

4.2 Type approved components

4.2.1 See Ch 2, Sec 15.

SECTION 2

DESIGN REQUIREMENTS

1 General

1.1

1.1.1 *All control systems essential for the propulsion, control and safety of the ship shall be independent or designed such that failure of one system does not degrade the performance of another system.*

1.1.2 Controlled systems are to have manual operation.

Failure of any part of such systems shall not prevent the use of the manual override.

1.1.3 Automation systems are to have constant performance.

1.1.4 Safety functions are to be independent of control and monitoring functions. As far as practicable, control and monitoring functions are also to be independent.

1.1.5 Control, monitoring and safety systems are to have self-check facilities. In the event of failure, an alarm is to be activated.

In particular, failure of the power supply of the automation system is to generate an alarm.

1.1.6 When a programmable electronic system is used for control, alarm or safety systems, it is to comply with the requirements of Sec 3.

2 Power supply of automation systems

2.1 General

2.1.1 (1/7/2020)

Automation systems are to be powered from two sources of power by means of two independent feeders. Failure of each of these power supplies is to generate an alarm.

Batteries or pneumatic or hydraulic accumulators, installed to allow the system to be continuously powered, are not considered as a duplication of the power supply.

Note 1: batteries constituting the emergency source of electrical power may be considered as one of the two required sources.

2.1.2 (1/7/2020)

Power supply circuits are to be such that no direct connections to any point of the ship's main power supply system are provided (e.g. by means of isolating transformers).

2.1.3 (1/7/2020)

Each automation system is to have separate power supplies with short circuit and overload protection.

Safety systems are to have power supplies as far as possible separate from control and alarm system, or an equivalent safety level is to be ensured.

2.1.4 (1/7/2020)

In addition to what above, the automation systems are to be continuously powered by means of batteries or pneumatic or hydraulic accumulators.

2.1.5 (1/7/2020)

The capacity of the batteries, or pneumatic or hydraulic accumulators is to be sufficient to allow the normal operation of the alarm and safety system for at least half an hour.

3 Control systems

3.1 General

3.1.1 In the case of failure, the control systems used for essential services are to remain in their last position they had before the failure.

3.2 Local control

3.2.1 Each system is to be able to be operated manually from a position located so as to enable visual control of operation. For detailed instrumentation for each system, refer to Chapter 1 and Chapter 2.

It shall also be possible to control the auxiliary machinery, essential for the propulsion and safety of the ship, at or near the machinery concerned.

3.3 Remote control systems

3.3.1 When several control stations are provided, control of machinery is to be possible at one station at a time.

3.3.2 *At each location there shall be an indicator showing which location is in control of the propulsion machinery.*

3.3.3 Remote control is to be provided with the necessary instrumentation, in each control station, to allow effective control (correct function of the system, indication of control station in operation, alarm display).

3.3.4 When transferring the control location, no significant alteration of the controlled equipment is to occur. Transfer of control is to be protected by an audible warning and acknowledged by the receiving control location. The main control location is to be able to take control without acknowledgement.

3.4 Automatic control systems

3.4.1 *Automatic starting, operational and control systems shall include provisions for manually overriding the automatic controls.*

3.4.2 Automatic control is to be stable in the range of the controller in normal working conditions.

3.4.3 Automatic control is to have instrumentation to verify the correct function of the system.

4 Control of propulsion machinery

4.1 Remote control

4.1.1 The requirements mentioned in [3] are to be applied for propulsion machinery.

4.1.2 *The design of the remote control system shall be such that in case of its failure an alarm will be given.*

4.1.3 Supply failure (voltage, fluid pressure, etc.) in propulsion plant remote control is to activate an alarm at the control position. In the event of remote control system failure and unless the Society considers it impracticable, the preset speed and direction of thrust are to be maintained until local control is in operation. This applies in particular in the case of loss of electric, pneumatic or hydraulic supply to the system.

4.1.4 *Propulsion machinery orders from the navigation bridge shall be indicated in the main machinery control room, and at the manoeuvring platform.*

4.1.5 *The control shall be performed by a single control device for each independent propeller, with automatic performance of all associated services, including, where necessary, means of preventing overload of the propulsion machinery. Where multiple propellers are designed to operate simultaneously, they must be controlled by one control device.*

4.1.6 *Indicators shall be fitted on the navigation bridge, in the main machinery control room and at the manoeuvring platform, for:*

propeller speed and direction of rotation in the case of fixed pitch propellers; and

propeller speed and pitch position in the case of controllable pitch propellers.

4.1.7 *The main propulsion machinery shall be provided with an emergency stopping device on the navigation bridge which shall be independent of the navigation bridge control system.*

In the event that there is no reaction to an order to stop, provision is to be made for an alternative emergency stop. This emergency stopping device may consist of a simple and clearly marked control device, for example a push-button. This fitting is to be capable of suppressing the propeller thrust, whatever the cause of the failure may be.

4.2 Remote control from navigating bridge

4.2.1 Where propulsion machinery is controlled from the navigating bridge, the remote control is to include an automatic device such that the number of operations to be carried out is reduced and their nature is simplified and such that control is possible in both the ahead and astern directions. Where necessary, means for preventing overload and running in critical speed ranges of the propulsion machinery is to be provided.

Note 1: Arrangements which are not in compliance with the provisions of this Article may be considered for the following ships:

- ships of less than 24 m in length
- cargo ships of less than 500 tons gross tonnage
- ships to be assigned restricted navigation notations
- non-propelled units.

4.2.2 On board ships fitted with remote control, direct control of the propulsion machinery is to be provided locally. The local direct control is to be independent from the remote control circuits, and takes over any remote control when in use.

4.2.3 Each local control position, including partial control (e.g. local control of controllable pitch propellers or clutches) is to be provided with means of communication with each remote control position. The local control positions are to be independent from remote control of propulsion machinery and continue to operate in the event of a blackout (see Note 1 in [4.2.1]).

4.2.4 *Remote control of the propulsion machinery shall be possible only from one location at a time; at such locations interconnected control positions are permitted.*

4.2.5 *The transfer of control between the navigating bridge and machinery spaces shall be possible only in the main machinery space or the main machinery control room. The system shall include means to prevent the propelling thrust from altering significantly, when transferring control from one location to another (see Note 1 in [4.2.1]).*

4.2.6 At the navigating bridge, the control of the routine manoeuvres for one line of shafting is to be performed by a single control device: a lever, a handwheel or a push-button board. However each mechanism contributing directly to the propulsion, such as the engine, clutch, automatic brake or controllable pitch propeller, is to be able to be individually controlled, either locally or at a central monitoring and control position in the engine room (see Note 1 in [4.2.1]).

4.2.7 Remote starting of the propulsion machinery is to be automatically inhibited if a condition exists which may damage the machinery, e.g. shaft turning gear engaged, drop of lubrication oil pressure or brake engaged.

4.2.8 As a general rule, the navigating bridge panels are not to be overloaded by alarms and indications which are not required.

4.3 Automatic control

4.3.1 The requirements in [3] are applicable. In addition, the following requirements are to be considered, if relevant.

4.3.2 *Main turbine propulsion machinery and, where applicable, main internal combustion propulsion machinery and auxiliary machinery shall be provided with automatic shutoff arrangements in the case of failures such as lubricating oil supply failure which could lead rapidly to complete breakdown, serious damage or explosion.*

4.3.3 The automatic control system is to be designed on a fail safe basis, and, in the event of failure, the system is to be adjusted automatically to a predetermined safe state.

4.3.4 When the remote control system of the propulsion machinery includes automatic starting, the number of automatic consecutive attempts is to be limited at a preset value of the starting air pressure permitting 3 attempts, and an alarm is to be provided, on the navigation bridge and in the machinery space.

4.3.5 Operations following any setting of the bridge control device (including reversing from the maximum ahead service speed in case of emergency) are to take place in an automatic sequence and with acceptable time intervals, as prescribed by the manufacturer.

4.3.6 For steam turbines, a slow turning device is to be provided which operates automatically if the turbine is stopped longer than admissible. Discontinuation of this automatic turning from the bridge is to be possible.

4.4 Automatic control of propulsion and manoeuvring units

4.4.1 When the power source actuating the automatic control of propelling units fails, an alarm is to be triggered. In such case, the preset direction of thrust is to be maintained long enough to allow the intervention of engineers. Failing this, minimum arrangements, such as stopping of the shaft line, are to be provided to prevent any unexpected reverse of the thrust. Such stopping may be automatic or ordered by the operator, following an appropriate indication.

4.5 Clutches

4.5.1 Where the clutch of a propulsion engine is operated electrically, pneumatically or hydraulically, an alarm is to be given at the control station in the event of loss of energy; as far as practicable, this alarm is to be triggered while it is still possible to operate the equipment (see Note 1 in [4.2.1]).

4.5.2 When only one clutch is installed, its control is to be fail-set. Other arrangements may be considered in relation to the configuration of the propulsion machinery.

4.6 Brakes

4.6.1 Automatic or remote controlled braking is to be possible only if:

- propulsion power has been shut off
- the turning gear is disconnected
- the shaftline speed (r.p.m.) is below the threshold stated by the builder (see Note 1 in [4.2.1]).

5 Remote control of valves

5.1

5.1.1 The following requirements are applicable to valves whose failure could impair essential services.

5.1.2 Failure of the power supply is not to permit a valve to move to an unsafe condition.

5.1.3 An indication is to be provided at the remote control station showing the actual position of the valve or whether the valve is fully open or fully closed.

5.1.4 In case of failure of manually operated or automatic remote control systems, the local control of valves is to be possible.

5.1.5 Equipment located in places which may be flooded is to be capable of operation even if submerged.

6 Alarm system

6.1 General requirements

6.1.1 Alarms are to be visual and audible and are to be clearly distinguishable, in the ambient noise and lighting in the normal position of the personnel, from any other signals.

6.1.2 Sufficient information is to be provided for proper handling of alarms.

6.1.3 The alarm system is to be of the self-check type; failure within the alarm system, including the outside connection, is to activate an alarm. The alarm circuits are to be independent from each other. All alarm circuits are to be protected so as not to endanger each other.

6.2 Alarm functions

6.2.1 Alarm activation

Alarms are to be activated when abnormal conditions appear in the machinery, which need the intervention of personnel on duty, and on the automatic change-over, when standby machines are installed.

An existing alarm is not to prevent the indication of any further fault.

6.2.2 Acknowledgement of alarm

The acknowledgment of an alarm consists in manually silencing the audible signal and additional visual signals (e.g. rotating light signals) while leaving the visual signal on

the active control station. Acknowledged alarms are to be clearly distinguishable from unacknowledged alarms. Acknowledgement should not prevent the audible signal to operate for new alarm.

Alarms shall be maintained until they are accepted and visual indications of individual alarms shall remain until the fault has been corrected, when the alarm system shall automatically reset to the normal operating condition.

Acknowledgement of alarms is only to be possible at the active control station.

Alarms, including the detection of transient faults, are to be maintained until acknowledgement of the visual indication.

Acknowledgement of visual signals is to be separate for each signal or common to a limited group of signals. Acknowledgement is only to be possible when the user has visual information on the alarm condition for the signal or all signals in a group.

6.2.3 Locking of alarms

Manual locking of separate alarms may be accepted when this is clearly indicated.

Locking of alarm and safety functions in certain operating modes (e.g. during start-up or trimming) is to be automatically disabled in other modes.

6.2.4 Time delay of alarms

It is to be possible to delay alarm activation in order to avoid false alarms due to normal transient conditions (e.g. during start-up or trimming).

6.2.5 Engineers' alarm

An engineers' alarm shall be provided to be operated from the engine control room or at the manoeuvring platform as appropriate, and shall be clearly audible in the engineers' accommodation.

6.2.6 Transfer of responsibility

Where several alarm control stations located in different spaces are provided, responsibility for alarms is not to be transferred before being acknowledged by the receiving location. Transfer of responsibility is to give an audible warning. At each control station it is to be indicated which location is in charge.

6.2.7 Alarm systems with limited number of monitored positions

For alarms with a limited number of monitored positions, relaxation to the requirements of [6.2] may be granted at judgement of the Society

7 Safety system

7.1 Design

7.1.1 System failures

A safety system is to be designed so as to limit the consequence of failures. It is to be constructed on the fail-to-safety principle.

The safety system is to be of the self-check type; as a rule, failure within the safety system, including the outside connection, is to activate an alarm.

7.2 Function

7.2.1 Safety activation

The safety system is to be activated automatically in the event of identified conditions which could lead to damage of associated machinery or systems, such that:

- normal operating conditions are restored (e.g. by the starting of the standby unit), or
- the operation of the machinery is temporarily adjusted to the prevailing abnormal conditions (e.g. by reducing the output of the associated machinery), or
- the machinery is protected, as far as possible, from critical conditions by shutting off the fuel or power supply, thereby stopping the machinery (shutdown), or appropriate shutdown.

7.2.2 Safety indication

When the safety system has been activated, it is to be possible to trace the cause of the safety action. This is to be accomplished by means of a central or local indication.

When a safety system is made inoperative by a manual override, this is to be clearly indicated at corresponding control stations.

Automatic safety actions are to activate an alarm at predefined control stations.

7.3 Shutdown

7.3.1 For shutdown systems of machinery, the following requirements are to be applied:

- when the system has stopped a machine, the latter is not to be restarted automatically before a manual reset of the safety system has been carried out
- the shutdown of the propulsion system is to be limited to those cases which could lead to serious damage, complete breakdown or explosion.

7.4 Standby systems

7.4.1 For the automatic starting system of the standby units, the following requirements are to be applied:

- faults in the electrical or mechanical system of the running machinery are not to prevent the standby machinery from being automatically started
- when a machine is on standby, ready to be automatically started, this is to be clearly indicated at its control position
- the change-over to the standby unit is to be indicated by a visual and audible alarm
- means are to be provided close to the machine, to prevent undesired automatic or remote starting (e.g. when the machine is being repaired)
- automatic starting is to be prevented when conditions are present which could endanger the standby machine.

7.5 Testing

7.5.1 The safety systems are to be tested in accordance with the requirements in Sec 8.

SECTION 3

COMPUTER BASED SYSTEMS

1 Scope

1.1 General

1.1.1 (1/7/2024)

These requirements apply to design, construction, commissioning and maintenance of computer based systems where they depend on software for the proper achievement of their functions.

1.1.2 (1/7/2024)

These requirements apply to systems which provide control, alarm, monitoring, safety or internal vessel communication functions that are subject to classification requirements.

1.1.3 (1/7/2024)

Computer-based systems that are covered by statutory regulations are excluded from the requirements of this Section.

Guidance:

Examples of such systems are navigation systems and radio communication system required by SOLAS chapter V and IV, and vessel loading instrument/stability computer.

Note 1: For loading instrument/stability computer, IACS recommendation no. 48 may be considered.

1.2 Reference to other regulations and standards

1.2.1 (1/7/2024)

For the purposes of this Section, the applicable requirements in Sec 4, Sec 5 and Sec 8 are to be complied with.

1.2.2 Informative standards (1/7/2024)

For the purposes of this Section, the following standards are listed for information and may be used for the development of hardware/software of computer based systems:

- IEC 61508:2010 "Functional safety of electrical/electronic/programmable electronic safety related Systems"
- ISO/IEC 12207:2017 "Systems and software engineering - Software life cycle processes"
- ISO 9001:2015 "Quality Management Systems - Requirements"
- ISO/IEC 90003:2018 "Software engineering - Guidelines for the application of ISO 9001:2015 to computer software"
- IEC 60092-504:2016 "Electrical installations in ships - Part 504: Special features - Control and instrumentation"
- ISO/IEC 25000:2014 "Systems and software engineering - Systems and software Quality Requirements and Evaluation (SQuaRE) - Guide to SQuaRE"

- ISO/IEC 25041:2012 "Systems and software engineering - Systems and software Quality Requirements and Evaluation (SQuaRE) - Evaluation guide for developers, acquirers and independent evaluators"
- IEC 61511:2016 "Functional safety - Safety instrumented systems for the process industry sector"
- ISO/IEC 15288:2015 "Systems and software engineering - system life cycle process"
- ISO 90007:2017 Quality management – Guidelines for configuration management
- ISO 24060:2021 Ships and marine technology - Ship software logging system for operational technology.

Other industry standards may also be considered.

1.3 Structure

1.3.1 (1/7/2024)

The general certification requirements for computer-based systems and the relation to type approval is described in [2]. The requirements and extent of verification of a computer-based system depends on its categorization into one of three categories. The categories are described in [3].

The requirements of this Section cover the lifecycle of computer-based system from design through operations. The requirements are split into groups representing the different phases of the life cycle and the roles responsible for fulfilling the requirements.

The activities related to the development and delivery of a computer-based system is described in [4], while the activities related to the maintenance in the operational phase are described in [5].

Management of changes to software and systems is given special attention in this Section, and the main aspects of a management of change process are described in [6].

Most requirements in this Section are related to the way of working, and thus focus on activities to be performed, but it also contains some technical requirements. The technical requirements on computer-based systems have been gathered in [8].

Each activity contains a requirement part which describes the minimum requirements on the role in question, and a part which describes the Society's verification of the activity in question.

1.4 Abbreviations

1.4.1 (1/7/2024)

For the purpose of this Section the abbreviations in Tab 1 apply.

Table 1 : Abbreviations (1/7/2024)

Abbreviation	Expansion
Cat I	Category one systems as defined in
Cat II	Category two systems as defined in [3.1]
Cat III	Category three systems as defined in [3.1]
COTS	Commercial off-the-shelf
FAT	Factory acceptance test
FMEA	Failure mode and effect analysis
IT	Information technology
OT	Operational technology
PMS	Planned maintenance system
SAT	System acceptance test
SOST	System of systems test
SSLS	Ship software logging system

1.5 Definitions

1.5.1 Black-box description (1/7/2024)

A description of a system's functionality and behaviour and performance as observed from outside the system in question.

1.5.2 Black-box test methods (1/7/2024)

Verification of the functionality, performance, and robustness of a system, sub-system or component by only manipulating the inputs and observing the outputs. This does not require any knowledge of the system's inner workings and focuses only on the observable behaviour of the system/component under test in order to achieve the desired level of verification.

1.5.3 Computer-based system (CBS) (1/7/2024)

A programmable electronic device, or interoperable set of programmable electronic devices, organized to achieve one or more specified purposes such as collection, processing, maintenance, use, sharing, dissemination, or disposition of information. CBSs onboard include IT and OT systems. A CBS may be a combination of subsystems connected via network. Onboard CBSs may be connected directly or via public means of communications (e.g. Internet) to ashore CBSs, other vessels' CBSs and/or other facilities.

1.5.4 Failure mode description (1/7/2024)

A document describing the effects due to failures in the system, not failures in the equipment supported by the system. The following aspects shall be covered:

- list of failures which are subject to assessment, with

- description of the system response to each of the above failures
- comments to the consequence of each of these failures.

1.5.5 Owner (1/7/2024)

The organization or person which orders the vessel in the construction phase or the organization which owns or manages the vessel in service. In the context of this Section this is a defined role with specific responsibilities.

1.5.6 Parameterization (1/7/2024)

To configure and tune system and software functionality by changing parameters. It does not usually require-computer programming and is normally done by the system supplier or a service provider, not the operator or end-user.

1.5.7 Programmable device (1/7/2024)

Physical component where software is installed.

1.5.8 Robustness (1/7/2024)

The ability to respond to abnormal inputs and conditions.

1.5.9 Systems integrator (1/7/2024)

Single organization or a person coordinating interaction between suppliers of systems and sub-systems on all stages of life cycle of computer-based systems in order to integrate them into a verified vessel-wide system of systems and to provide proper operation and maintenance of the computer-based systems. In the context of this Section this is a defined role with specific responsibilities. During the design and delivery phase the Shipyard is the default Systems integrator, during operations phase the Owner is the default.

1.5.10 Service supplier (1/7/2024)

A person or company, not employed by an IACS Member, who at the request of an equipment manufacturer, shipyard, vessel's owner or other client acts in connection with inspection work and provides services for a ship or a mobile offshore unit such as measurements, tests or maintenance of safety systems and equipment, the results of which are used by surveyors in making decisions affecting classification or statutory certification and services.

1.5.11 Supplier (1/7/2024)

A generic term used for any organisation or person that is a contracted or a subcontracted provider of services, system components, or software.

1.5.12 System (1/7/2024)

A combination of components, equipment and logic which has a defined purpose, functionality, and performance. In the context of this Section, a specific system is delivered by one system supplier.

1.5.13 System of systems (1/7/2024)

A system which is made up of several systems.

In the context of this Section, the system of systems encompasses all monitoring, control and safety systems delivered from the Shipyard as a part of a vessel.

1.5.14 System supplier (1/7/2024)

An organisation or person that is contracted or a subcontracted provider of system components or software under the coordination of the Systems integrator. In the context of this Section this is a defined role with specific responsibilities.

1.5.15 Sub-system (1/7/2017)

Identifiable part of a system, which may perform a specific function or set of functions.

1.5.16 Programmable device (1/7/2017)

Physical component where software is installed.

1.5.17 Software component (1/7/2024)

A standalone piece of code that provides specific and closely coupled functionality.

1.5.18 Software master files (1/7/2024)

The computer-files that constitutes the original source of the software. For custom made software this may be readable source-code files, and for COTS software it may be different forms of binary files.

1.5.19 Software-structure (1/7/2024)

Overview of how the different software components interact and is commonly referred to as the Software Architecture, or Software Hierarchy.

1.5.20 Simulation tests (1/7/2024)

Monitoring, control, or safety system testing where the equipment under control is partly or fully replaced with simulation tools, or where parts of the communication network and lines are replaced with simulation tools.

1.5.21 Society Certificate (1/7/2024)

Compliance document issued by a Class Society stating:

- conformity with applicable rules and requirements
- that the tests and inspections have been carried out on
- the finished certified component itself; or
- on samples taken from earlier stages in the production of the component, when applicable.
- that the inspection and tests were performed in the presence of the Surveyor or in accordance with special agreements, i.e. Alternative Certification Scheme (ACS).

1.5.22 Type approval Certificate (1/7/2024)

Compliance document issued by the Society by which the Society declares that a product design meets a minimum set of technical requirements.

1.5.23 Vessel (1/7/2024)

Ship or offshore unit where the computer-based system is to be installed.

Figure 1 : Illustrative System Hierarchy (1/7/2017)

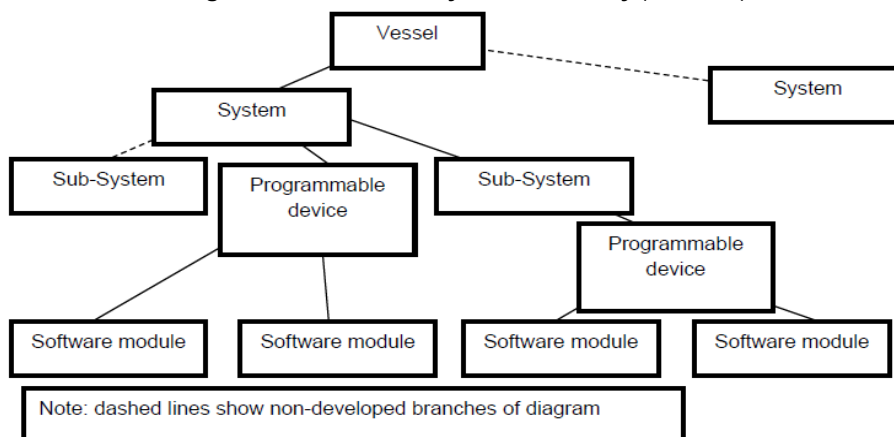

2 Approval of system and components

2.1

2.1.1 System certification (1/7/2024)

Computer-based systems that are necessary to accomplish vessel-functions of category II or category III (as defined in [3.1.1]) are to be delivered with a vessel-specific Society certificate. The objective of the vessel-specific system certification is to confirm that design and manufacturing of the system has been completed and that the system complies with applicable rules of the Society.

Vessel-specific system certification consist of two main verification activities:

- a) Assessment of vessel-specific documentation (see [4.2] and [6])

- b) Survey and testing of the system to be delivered to the vessel (see [4.2.7])

The Society may accept Alternative Certification Scheme (ACS) provided that the requirements are met, and that the system is provided with a vessel-specific certificate.

2.1.2 Type approval of computer-based systems (1/7/2024)

Computer-based systems that are routinely manufactured and include standardized software functions may be type approved in accordance with specified rules of the Society. Hardware is to be documented according to the requirement in [4.2.4].

The type approval consist of two main verification activities:

- a) Assessment of type-specific documentation
- b) Survey and testing of the standardized functions.

Type approval will normally not yield exemption from vessel-specific system certification since vessel-specific functions, parameter configurations and installation elements demand vessel-specific verification.

3 System categories

3.1 System category definitions

3.1.1 (1/7/2024)

The categorization of a system in the context of this Section is based on the potential severity of the consequences if the system serving the function fails. Tab 2 provides the definitions of the categories.

3.2 Class Societies' scope

3.2.1 (1/7/2024)

Category I systems are normally not subject to verification by the Society, as failure of these systems is not to lead to dangerous situations. However, information pertinent to category I systems is to be required upon request to determine the correct category or ensure that they do not influence the operation of systems in category II and category III.

3.3 System category examples

3.3.1 (1/7/2024)

The category of a system is always to be evaluated in the context of the specific vessel in question; thus, the categorization of a system may vary from one vessel to the next. This means that the examples of categories below are given as guidance only. For determining the categorization of systems for a specific vessel, see [4.3.3].

Examples of category I systems:

Fuel monitoring system, maintenance support system, diagnostics and troubleshooting system, closed circuit television, cabin security, entertainment system, fish detection system.

Examples of category II systems:

Fuel oil treatment system, alarm monitoring and safety systems for propulsion and auxiliary machinery, Inert gas system, control, monitoring and safety system for cargo containment system.

Examples of category III systems:

Propulsion control system, steering gear control system, electric power system (including power management system), dynamic positioning system (IMO classes 2 and 3).

Note 1: The list of example systems in [3.3.1] is not exhaustive.

4 Requirements on development and certification of computer-based system

4.1 General requirements

4.1.1 Life cycle approach with appropriate standards (1/7/2024)

Requirement:

A global top-down approach is to be undertaken in the design and development of both hardware and software and the integration in sub-systems, systems, and system of systems, spanning the complete system lifecycle. This approach is to be based on the standards as listed herein or other standards recognized by the Society.

Society's verification:

This is verified by the Society as a part of the quality management system verification described in [4.1.2].

4.1.2 Quality management system (1/7/2024)

Systems integrators and system suppliers are, in the development of computer-based systems for category II and category III, to comply to a recognised quality standard such as ISO 9001; also incorporating principles of IEC/ISO 90003.

The quality management system is as a minimum to include the topics in Tab 3, applicable for both category II and category III systems.

Table 2 : System categories (1/7/2024)

Category	Failure Effects	Typical System functionality
I	Those systems, failure of which will not lead to dangerous situations for human safety, safety of the vessel and/or a threat to the environment.	Monitoring, informational and administrative functions
II	Those systems, failure of which could eventually lead to dangerous situations for human safety, safety of the vessel and/or a threat to the environment.	Vessel alarm, monitoring and control functions which are necessary to maintain the vessel in its normal operational and habitable conditions
III	Those systems, failure of which could immediately lead to dangerous or catastrophic situations for human safety, safety of the vessel and/or a threat to the environment.	<ul style="list-style-type: none"> Control functions for maintaining the vessel's propulsion and steering Vessel safety functions

Table 3 : Quality management system (1/7/2024)

Area		Role	
N	Topic	System supplier	Systems integrator
1	Responsibilities and competency of the staff	x	x
2	The complete lifecycle of delivered software and of associated hardware	x	x
3	Specific procedure for unique identification of a computer-based system, it's components and versions	x	
4	Creation and update of the vessel's system architecture		x
5	Organization set in place for acquisition of software and related hardware from suppliers	x	x
6	Organization set in place for software code writing and verification	x	
7	Organization set in place for system validation before integration in the vessel	x	
8	Specific procedure for conducting and approving of systems at FAT and SAT	x	x
9	Creation and update of system documentation	x	
10	Specific procedure for software modification and installation on board the vessel, including interactions with shipyard and owner	x	x
11	Specific procedures for verification of software code	x	
12	Procedures for integrating systems with other systems and testing of the system of systems for the vessel	x	x
13	Procedures for managing changes to software and configurations before FAT	x	
14	Procedures for managing and documenting changes to software and configurations after FAT	x	x
15	Checkpoints for the organization's own follow-up of adherence to the quality management system	x	x

Society's verification:

The quality management system may be verified by two alternative means:

- The Society confirming that the quality management system is certified as compliant to a recognized standard by an organisation with accreditation under a national accreditation scheme.
- The Society confirming compliance to a standard through a specific assessment of the quality management system. The documentation requirements will be defined per case.

4.2 Requirements on the system supplier

4.2.1 Define and follow a quality plan (1/7/2024)

Requirement:

The system supplier is to document that the quality management system is applied for the design, construction, delivery, and maintenance of the specific system to be delivered.

All applicable items described in [4.1.2] (for the system supplier role) are to be demonstrated to exist and being followed, as relevant.

Society's verification:

Category I: No documentation required

Category II and III: The quality plan is to be available during survey (FAT) or submitted for information upon request (I).

4.2.2 Unique identification of systems and software (1/7/2024)

Requirement:

A method for unique identification of a system, its different software components and different revisions of the same software component is to be applied. The method is to be applied throughout the lifecycle of the system and the software.

See also [7.2] for related technical requirements on the system in question.

The documentation of the method is typically a part of the quality management system, see [4.1.2].

Society's verification:

Category I: Not required

Category II and III: Application of the identification system is verified as a part of the FAT (see [4.2.7]) and SAT ([4.3.6]).

4.2.3 System description (1/7/2024)

Requirement:

The system's specification and design are to be determined and documented in a system description. In addition to serve as a specification for the detailed design and implementation, the purpose of the system description is to document that the entire system-delivery is according to the specifications and in compliance with applicable rules and regulations.

The system description is to contain information of the following:

- Purpose and main functions, including any safety aspects
- System category as defined
- Key performance characteristics
- Compliance with the technical requirements and Society rules
- User interfaces/mimics
- Communication and Interface aspects
 - Identification and description of interfaces to other vessel systems
- Hardware-arrangement related aspects:
 - Network-architecture/topology, including all network components like switches, routers, gateways, firewalls etc.
 - Internal structure with regards to all interfaces and hardware nodes in the system (e.g. operator stations, displays, computers, programmable devices, sensors, actuators, I/O modules etc)
 - I/O allocation (mapping of field devices to channel, communication link, hardware unit, logic function)
 - Power supply arrangement
 - Failure mode description.

Guidance:

The information listed above is in this Section collectively referred to as the system description. It may however be divided into a number of different documents and models.

Society's verification:

Category I: The system description documentation is to upon request be submitted for information (I).

Category II and III: The system description documentation is to be submitted for approval (A).

4.2.4 Environmental compliance of hardware components (1/7/2024)

Requirement:

Evidence of environmental type testing according to Sec 8 regarding hardware elements included in the system and sub-systems is to be submitted to the Society.

Society's verification:

Category I: This requirement is not mandatory for category I systems. Reference to Type approval certificate or other evidence of type testing is upon request to be submitted for information (I) see [3.2]

Category II and III: Reference to Type approval certificate or other evidence of type testing is to be submitted for information (I).

4.2.5 Software code creation, parameterization, and testing (1/7/2024)

Requirement:

The software created, changed, or configured for the delivery project is to be developed and have the quality assurance activities assessed according to the selected standard(s) as described in the quality plan.

The quality assurance activities may be performed on several levels of the software-structure and is to include both custom-made software and configured components (e.g. software libraries) as appropriate.

The verification of the software is to as a minimum verify the following aspects based on black-box methods:

- Correctness, completeness and consistency of any parameterization and configuration of software components
- Intended functionality
- Intended robustness

For components in systems of Category II and III, the scope, purpose, and results of all performed reviews, analyses, tests, and other verification activities are to be documented in test reports.

Guidance:

Some of the methods utilized in this activity are sometimes referred to as "software unit test" or "developer test" and may also include verification methods like code-reviews and static- or dynamic code analysis.

Society's verification:

Category I: No documentation required

Category II and III: Software test reports are upon request to be submitted for information (I).

4.2.6 Internal system testing before FAT (1/7/2024)

Requirement:

The system is to as far as practicable be tested before the FAT. The main purpose of the system test is for the system supplier to verify that the entire system delivery is according to the specifications, approved documentation and in compliance with applicable rules and regulations; and further, that the system is completed and ready for the FAT.

The testing is at least to verify the following aspects of the system:

- Functionality
- Effect of faults and failures (including diagnostic functions, detection, alerts response)
- Performance
- Integration between software and hardware components
- Human-machine interfaces
- Interfaces to other systems

Faults are to be simulated as realistically as possible to demonstrate appropriate system fault detection and system response.

Some of the testing may be performed by utilizing simulators and replica hardware.

The test-environment is to be documented, including a description of any simulators, emulators, test-stubs, test-

management tools, or other tools affecting the test environment and its limitations.

Test cases and test results are to be documented in test programs and test reports respectively.

Society's verification:

Category I: No documentation required.

Category II and III: Internal system test report is to be made available during FAT or submitted upon request (I).

4.2.7 Factory acceptance testing (FAT) before installation on board (1/7/2024)

Requirement:

A factory acceptance test (FAT) is to be arranged for the system in question. The main purpose of the FAT is to demonstrate to the Society that the system is completed and compliant with applicable classification rules, thus enabling issuance of a Society Certificate for the system.

The FAT test program is to cover a representative selection of the test items from the internal system test (described in [4.2.6]), including normal system functionality and response to failures.

For category II and III systems, network testing to verify the network resilience requirements in [7.3.1] is to be performed. If agreed by all parties, the network testing may be performed as a part of the system test onboard the vessel.

The FAT is as a rule to be performed with the project specific software operating on the actual hardware components to be installed on board, with necessary means for simulation of functions and failure responses, however other solutions such as replica hardware or simulated hardware (emulators) may be agreed with the Society.

For each test-case it is to be noted if the test passed or failed, and the test-results are to be documented in a test report. The test report is also to contain a list of the software (including software versions) that were installed in the system when the test was executed.

Guidance:

For complex systems there may be a large difference in scope between the "Internal system testing before FAT" activity and the FAT, while for some systems the scope may be identical.

Society's verification:

Category I: FAT not required.

Category II and III: The FAT program is to be approved (A) before the test is executed.

The FAT execution is to be witnessed by the Society.

The FAT report is to be submitted for information (I).

Additional FAT documentation including e.g., user manuals and internal system test report is to be made available during FAT or submitted upon request for information (I).

4.2.8 Secure and controlled software installation on the vessel (1/7/2024)

Requirement:

The initial installation and subsequent updates of the software components of the system is to be done according to a management of change procedure which has been agreed between the system supplier and the systems integrator.

The management of change procedure is to comply with the requirements in [6].

Cyber security measures are to be observed as described in Sec 4 and Sec 5.

Society's verification:

Category I: Not required.

Category II and III: The management of change procedure is upon request to be submitted for information (I).

4.3 Requirements on the systems integrator

4.3.1 Responsibilities (1/7/2024)

For the purposes of this Section, the Shipyard is considered as the systems integrator in the development and delivery phase unless another organization or person is explicitly appointed by the Shipyard.

4.3.2 Define and follow a quality plan (1/7/2024)

Requirement:

The systems integrator is to document that the quality management system is applied for the installation, integration, completion, and maintenance of the systems to be installed on board. All applicable items described in [4.1.2] (for the systems integrator role) are to be demonstrated to exist and being followed, as relevant.

Society's verification:

Category I: No documentation required.

Category II and III: The quality plan is to be made available during survey (at SAT/SOST) or upon request submitted for information (I).

4.3.3 Determining the category of the system in question (1/7/2024)

Requirement:

For each system delivery to a particular vessel, it is to be decided which category the system falls under based on the failure effects of the system (as defined in [3]). The category for a specific system is to be conveyed to the relevant system supplier. The Society may decide that a risk-assessment is needed to verify the proper system category.

Society's verification:

Category I, II and III: The category for the different systems is upon request to be documented and submitted for approval (A).

4.3.4 Risk assessment of the system (1/7/2024)

Requirement:

If requested by the Society, a risk assessment of a specific system in context of the specific vessel in question is to be performed and documented in order to determine the applicable category for the system.

Guidance:

IEC/ISO31010 "Risk management - Risk assessment techniques" may be used as guidance in order to determine method of risk assessment.

Society's verification:

Category I, II and III: The risk assessment report is upon request to be submitted for approval (A).

4.3.5 Define the vessel's system-architecture (1/7/2024)

Requirement:

The system of systems (SoS) is to be specified and documented. This architecture specification provides the basis for category determination and development of the different integrated systems by allocating functionality to individual systems and by identifying the main interfaces between the systems. It is also to serve as a basis for the testing of the integrated systems on the vessel level (see [4.3.7]).

The vessel's system architecture is to at least contain description of:

- Overview of the total systems architecture (the system of systems)
- Each system's purpose and main functionality
- Communication and interface aspects between different systems

Guidance:

See also Sec 4 for diagram of security zones and conduits

Society's verification:

Category I, II and III: The vessel's system architecture is upon request to be submitted for information (I).

4.3.6 System acceptance test (SAT) onboard the vessel (1/7/2024)

Requirement:

A system acceptance test is to be arranged onboard the vessel. The main purpose of the system acceptance test (SAT) is to verify the system functionality, after installation and integration with the applicable machinery/electrical/process systems on board including possible interfaces with other control and monitoring systems.

For each test-case it is to be noted if the test passed or failed, and the test-results are to be documented in a test report. The test report is also to contain a list of the software (including software versions) that were installed in the system when the test was executed.

Society's verification:

Category I: Not required.

Category II and III: The SAT program is to be submitted for approval (A) before the test is executed.

The SAT execution is to be witnessed by the Society.

The SAT report is to be submitted for information (I).

4.3.7 Testing of integrated systems on vessel-level (SOST) (1/7/2024)

Requirement:

Integration tests are to be conducted after installation and integration of the different systems in its final environment on board. The purpose of the tests is to verify the functionality of the complete installation (system of systems) including all interfaces and inter-dependencies in compliance with requirements and specifications.

The testing is at least to verify the following aspects of the system of systems:

- The overall functionality of the interacting systems as a whole
- Failure response between systems
- Performance
- Human-machine interfaces
- Interfaces between the different systems.

Guidance:

For complex systems there may be a large difference in scope between the "System acceptance test (SAT) onboard the vessel" activity and the SOST, while for some systems the scope may be overlapping or identical. It is possible to combine the two activities into one when the test scope is similar.

Society's verification:

Category I: Not required.

Category II and III: The SOST program is to be submitted for approval (A) before the test is executed.

The SOST execution is to be witnessed by the Society.

The SOST report is to be submitted for information (I).

4.3.8 Change management (1/7/2024)

Requirement:

The systems integrator is to follow procedures for management of change to the system as described in [6].

Society's verification:

Category I: No documentation requirements.

Category II and III: The management of change procedure is upon request to be submitted for information (I).

5 Requirements on maintenance of computer-based systems

5.1 Requirements on the Vessel Owner

5.1.1 Responsibilities (1/7/2024)

For the purposes of this Section, the vessel owner is considered to be the systems integrator in the operations phase unless another organization or person is explicitly appointed by the owner.

Accordingly, the Society is in a timely manner to be informed by the owner about the appointed systems integrator which is responsible for implementing any changes to the systems in conjunction with system supplier(s).

5.2 Requirements on the Systems integrator

5.2.1 Change management (1/7/2024)

Requirement:

The systems integrator is to ensure that necessary procedures for software and hardware change management exist on board, and that any software modification/upgrade are performed according to the procedure(s). For details about change management please see [6].

Changes to computer-based systems in the operational phase are to be recorded.

The records are to contain information about the relevant software versions and other relevant information as described in [6.11].

Society's verification:

Category I: No documentation requirements

Category II and III: See [6.12].

5.3 Requirements on the System Supplier

5.3.1 Change management (1/7/2024)

Requirement:

The system supplier is to follow procedures for maintenance of the system including procedures for management of change as described in [6].

Society's verification:

Category I: No documentation requirements

Category II and III: See [6.12].

5.3.2 Testing of changes before installation onboard (1/7/2024)

Requirement:

The system supplier is to make sure that the planned changes to a system have passed relevant in-house tests before the change is made to systems on board.

Society's verification:

Category I: No documentation requirements

Category II and III: See [6.12].

6 Management of change

6.1 General

6.1.1 (1/7/2024)

This Article provides requirements for the management of change throughout the lifecycle of a computer-based system. Different procedures for the management of change may be defined for specific phases in a system's lifecycle as the different phases typically involve different stakeholders. The Society's verification is described in [6.12].

6.2 Documented change management procedures

6.2.1 (1/7/2024)

Requirement:

The organization in question is to have defined and documented change management procedures applicable for the computer-based system in question covering both hardware and software. After FAT, the system supplier is to manage all changes to the system in accordance with the procedure. Examples could be qualification of new versions of acquired software, new hardware, modified control logic, changes to configurable parameters.

The procedure(s) is at least to describe the activities listed in [6.3] through [6.11]. The outcome of the impact analysis in [6.8] will determine to what extent the activities in [6.3] to [6.12] are to be performed. Change records (described in [6.11]) are always to be produced.

6.3 Agreement between relevant stakeholders

6.3.1 (1/7/2024)

Requirement:

The management of change process is to be coordinated and agreed between the relevant stakeholders along the different stages of the lifecycle of the computer-based system.

Guidance:

Typically, the management of change address at least three different stages:

- Development and internal verification before FAT; involving the system supplier and sub-suppliers.
- From FAT to handover of the vessel to the owner; involving the system supplier, the systems integrator, the Society, and the owner.
- In operation; involving the system supplier, service suppliers, the owner, and the Society

6.4 Approved software shall be under change management

6.4.1 (1/7/2024)

Requirement:

If changes are required to a system after it has been approved by applicable stakeholders (typically the systems integrator and the Society at FAT) the modifications are to follow defined change management procedures.

6.5 Unique identification of system and software versions

6.5.1 (1/7/2024)

Requirement:

The system supplier is to make sure that each system and software version is uniquely identifiable, see [4.2.2].

6.6 Handling of software master files

6.6.1 (1/7/2024)

Requirement:

There are to be defined mechanisms for handling of the files that constitutes the master-files for a software component. Personnel authorities are to be clearly defined along with the tools and mechanisms used to ensure the integrity of the master files.

6.7 Backup and restoration of onboard software

6.7.1 (1/7/2024)

Requirement:

It is to be clearly defined how to perform backup and restoration of the software components of a computer-based system onboard the vessel.

6.8 Impact analysis before change is made

6.8.1 (1/7/2024)

Requirement:

Before a change to the system is made, an impact analysis is to be performed in order to:

- Determine the criticality of the change.
- Determine the impact on existing documentation.
- Determine the needed verification and test activities.
- Determine the need to inform other stakeholders about the change.
- Determine the need to obtain approval from other stakeholders (e.g. Society and or Owner) before the change is made.

6.9 Roll-back in case of failed software changes

6.9.1 (1/7/2024)

Requirement:

When maintenance includes installation of new versions of the software in the system, it is to be possible to perform a rollback of the software to the previous installed version with the purpose of returning the system to a known, stable state.

Roll-backs are to be documented and analysed to find and eliminate the root cause.

6.10 Verification and validation of system changes

6.10.1 (1/7/2024)

Requirement:

To the largest degree practically possible, modifications are to be verified before being installed onboard.

After installation, the modification(s) is to be verified onboard according to a documented verification program containing:

- Verification that the new functionalities and/or improvements have had the intended effect.
- Regression test to verify that the modification has not had any negative effects on functionality or capabilities that was not expected to be affected.

6.11 Change records

6.11.1 (1/7/2024)

Changes to systems and software are to be documented in change records to allow for visibility and traceability of the changes. The change records is to contain at least the following items:

- The purpose for a change
- A description of the changes and modifications
- The main conclusions from the impact analysis (see [6.8])
- The identity and version of any new system or software version(s) (see [6.5])
- Test reports or tests summaries (see [6.10])

Documentation of the changes to software may be recorded in the planned maintenance system (PMS), in a software registry or equivalent.

6.12 Verification of change management by the Society

6.12.1 In operation (vessel in service) phase (1/7/2024)

The verification by the Society regarding the management of change in operation is generally performed during the annual survey of the vessel. Procedures for management of change and relevant change records (see [6.11]) are to be made available at the time of survey.

In the cases where the change requires approval from the Society up front, the relevant procedures and documentation for the change in question may be verified at that time.

6.12.2 During newbuilding (1/7/2024)

The verification of management of change in the newbuilding phase is divided into two; Procedures are verified as a part of the verification of the quality management system ([4.1.2]), while project specific implementation of the procedures are verified during FAT ([4.2.7]) and after FAT ([6.12.1])

7 Technical requirements on computer-based systems

7.1 General

7.1.1 (1/7/2024)

The Articles below contain technical requirements on computer-based systems. The compliance to these requirements are to be documented in the design documentation (see [4.2.3]) and verified through the verification activities described in this Section.

7.2 Reporting of system and software identification and version

7.2.1 System identification (1/7/2024)

The system is to provide means to identify its name, version, identifier, and manufacturer. It is recommended that the system can automatically report the status of its software to a ship software logging system (SSLS) as specified in the international standard ISO 24060.

7.3 Data links

7.3.1 General requirements for category II and III systems (1/7/2024)

Loss of a data link is to be specifically addressed in risk assessment analysis/FMEA. See [4.2.3].

- a) A single failure in data link is not to cause loss of vessel-functions of category III. Any effect of such failures is to meet the principle of fail-to-safe for the vessel-function(s) being served.
- b) For vessel-functions of category II and III, any loss of functionality in the remote control system is to be compensated for by local/manual means.
- c) The data link is to have means to prevent or cope with excessive communication rates.

- d) Data links are to be self-checking, detecting failures or performance issues on the link itself and data communication failures on nodes connected to the link.
- e) Detected failures are to initiate an alarm.

7.3.2 Specific requirements for wireless data links (1/7/2024)

- a) Category III systems are not to use wireless data links unless specifically considered by the Society on the basis of an engineering analysis carried out in accordance with an International or National Standard acceptable to the Society.

Other categories of systems may use wireless data links with the following requirements:

- b) Recognised international wireless communication system protocols are to be employed, incorporating:
- 1) Message integrity. Fault prevention, detection, diagnosis, and correction so that the received message is not corrupted or altered when compared to the transmitted message.
 - 2) Configuration and device authentication. It is only to permit connection of devices that are included in the system design.
 - 3) Message encryption. Protection of the confidentiality and or criticality of the data content.
 - 4) Security management. Protection of network assets, prevention of unauthorized access to network assets.
- c) The internal wireless system within the vessel is to comply with the radio frequency and power level requirements of International Telecommunication Union and flag state requirements.

- d) Consideration should be given to system operation in the event of port state and local regulations that pertain to the use of radio-frequency transmission prohibiting the operation of a wireless data communication link due to frequency and power level restrictions.

- e) For wireless data communication equipment, tests during harbour and sea trials are to be conducted to demonstrate that radio-frequency transmission does not cause failure of any equipment and does not self-fail as a result of electromagnetic interference during expected operating conditions.

7.4 Verification of technical requirements by the Society

7.4.1 (1/7/2024)

The implementation of the technical requirements provided in [7] is verified by the Society as part of the system description (see [4.2.3]), FAT (see [4.2.7]) and SAT (see [4.3.6]) described above.

8 Summary of documentation submittal

8.1

8.1.1 (1/7/2024)

Tab 4 and Tab 5 summarise the documentation to be submitted to the Society.

8.1.2 (1/7/2017)

The Society reserves the right to request the submission of additional documents if it is deemed necessary for the evaluation of the system, equipment or components.

Table 4 : Summary of documentation submittal by the system supplier (1/7/2024)

Item		Responsible role	System Category		
Paragraph reference	Document		I	II	III
[4.2.1]	Quality plan	System supplier	- (2)	I (1)	I (1)
[4.2.3]	System description	System supplier	I (1)	A	A
[4.2.4]	Environmental compliance	System supplier	I (1)	I	I
[4.2.5]	Software test reports	System supplier	-	I (1)	I (1)
[4.2.6]	System test report	System supplier	-	I (1)	I (1)
[4.2.7]	FAT program	System supplier	-	A	A
[4.2.7]	FAT report	System supplier	-	I	I
[4.2.7]	Additional FAT docs. (e.g. user manual, etc)	System supplier	-	I (1)	I (1)
[4.2.8]	Management of change procedure	System supplier	-	I (1)	I (1)
Note 1:					
A = Submitted for approval I = Provided (for information)					
(1) Upon request from the Society					
(2) "-" means: No requirement					

Table 5 : Summary of documentation submittal by the system integrator (1/7/2024)

Item		Responsible role	System Category		
Paragraph reference	Document		I	II	III
[4.3.2]	Quality plan	Systems integrator	- (2)	I (1)	I (1)
[4.3.3]	List of system categorizations	Systems integrator	A (1)	A (1)	A (1)
[4.3.4]	Risk assessment report	Systems integrator	A (1)	A (1)	A (1)
[4.3.5]	Vessel's system architecture	Systems integrator	I (1)	I (1)	I (1)
[4.3.6]	SAT program	Systems integrator	-	A	A
[4.3.6]	SAT report	Systems integrator	-	I	I
[4.3.7]	SOST program	Systems integrator	-	A	A
[4.3.7]	SOST report	Systems integrator	-	I	I
[4.3.8]	Change management procedure for software	Systems integrator	-	I (1)	I (1)

Note 1:
A = Submitted for approval I = Provided (for information)
(1) Upon request from the Society
(2) "-" means: No requirement

9 Summary of test witnessing and survey

9.1

9.1.1 (1/7/2024)

Tab 6 summarises the activities that are to be witnessed or surveyed by the Society. The responsible role is to facilitate the activity.

Table 6 : Summary of test witnessing and survey (1/7/2024)

Item		Responsible role	System Category		
Paragraph reference	Activity		I	II	III
[4.2.7]	FAT witnessing	System supplier	- (2)	x (1)	x
[4.3.6]	SAT witnessing	System integrator	-	x	x
[4.3.7]	SOST witnessing	System integrator	-	x	x
[6.12]	Verification of changes	System integrator	-	x	x

Note 1:
(1) Witnessing required
(2) "-" means: No requirement

SECTION 4

CYBER RESILIENCE OF SHIPS

1 Introduction

1.1 General

1.1.1 (1/7/2024)

Interconnection of computer systems on ships, together with the widespread use onboard of commercial-off-the-shelf (COTS) products, open the possibility for attacks to affect personnel data, human safety, the safety of the ship, and threaten the marine environment.

Attackers may target any combination of people and technology to achieve their aim, wherever there is a network connection or any other interface between onboard systems and the external world. Safeguarding ships, and shipping in general, from current and emerging

threats involves a range of measures that are continually evolving.

This Section establish a set of minimum functional and performance criteria to deliver a ship that can indeed be described as cyber resilient.

The minimum requirements in this Section applied consistently to the full threat surface using a goal-based approach are considered necessary to make cyber resilient ships.

1.2 Structure of this Section

1.2.1 (1/7/2024)

Tab 1 illustrate the structure of this Section

Table 1 : Structure of this Section (1/7/2024)

Introductory Part	1 Introduction 2 Definitions 3 Goals and Organization of Requirements
Main Part	4 Requirements 4.1 General 4.2 Identify 4.3 Protect 4.4 Detect 4.5 Respond 4.6 Recover
	5 Demonstration of compliance 5.1 General 5.2 During design and construction phases 5.3 Upon ship commissioning 5.4 During the operational life of the ship
Supplementary Part	6 Risk assessment for exclusion of CBS from the application of requirements (required only when systems are excluded from application of this Section)
	7: Summary of actions and documents 8: Summary of requirements and documents

1.3 Aim and purpose

1.3.1 (1/7/2024)

The aim of this Section is to provide a minimum set of requirements for cyber resilience of ships, with the purpose of providing technical means to stakeholders which would lead to cyber resilient ships.

This Section targets the ship as a collective entity for cyber resilience and is intended as a base for the complementary application of other industry standards addressing cyber resilience of onboard systems, equipment and components.

Minimum requirements for cyber resilience of on-board systems and equipment are given in Sec 5.

1.4 Scope of applicability

1.4.1 Vessels in scope (1/7/2024)

This Section is applicable to the following vessels:

- Passenger ships (including passenger high-speed craft) engaged in international voyages
- Cargo ships of 500 GT and upwards engaged in international voyages
- High speed craft of 500 GT and upwards engaged in international voyages
- Mobile offshore drilling units of 500 GT and upwards
- Self-propelled mobile offshore units engaged in construction (i.e. wind turbine installation maintenance

and repair, crane units, drilling tenders, accommodation, etc)

This Section may be used as non-mandatory guidance to the following.

- Ships of war and troopships
- Cargo ships less than 500 GT
- Vessels not propelled by mechanical means
- Wooden ships of primitive build
- Passenger yachts (passengers not more than 12)
- Pleasure yachts not engaged in trade
- Fishing vessels
- Site specific offshore installations (i.e. FPSOs, FSUs, etc.)

1.4.2 Systems in scope (1/7/2024)

This Section applies to:

- a) Operational Technology (OT) systems onboard ships, i.e. those CBSs using data to control or monitor physical processes that can be vulnerable to cyber incidents and, if compromised, could lead to dangerous situations for human safety, safety of the vessel and/or threat to the environment.

In particular, the CBSs used for the operation of the following ship functions and systems, if present onboard, are to be considered:

- Propulsion
- Steering
- Anchoring and mooring
- Electrical power generation and distribution
- Fire detection and extinguishing systems
- Bilge and ballast systems, loading computer
- Watertight integrity and flooding detection
- Lighting (e.g. emergency lighting, low locations, navigation lights, etc.)
- Any required safety system whose disruption or functional impairing may pose risks to ship operations (e.g. emergency shutdown system, cargo safety system, pressure vessel safety system, gas detection system, etc.).

In addition, the following systems are to be included in the scope of applicability of this Section:

- Navigational systems required by statutory regulations
- Internal and external communication systems required by class rules and statutory regulations.

For navigation and radiocommunication systems, the application of IEC 61162-460 or other equivalent standards in lieu of the required security capabilities in Sec 5, [4] may be accepted by the Society, on the condition that requirements in this Section are complied with.

- b) Any Internet Protocol (IP)-based communication interface from CBSs in scope of this Section to other systems. Examples of such systems are, but not limited to, the following:

- passenger or visitor servicing and management systems

- passenger-facing networks
- administrative networks
- crew welfare systems
- any other systems connected to OT systems, either permanently or temporarily (e.g. during maintenance).

The cyber incidents considered in this Section are events resulting from any offensive manoeuvre that targets OT systems onboard ships as defined in [2].

1.4.3 System Category (1/7/2024)

System categories are defined in Sec 3 on the basis of the consequences of a system failure to human safety, safety of the vessel and/or threat to the environment.

1.4.4 IACS Documents on Computer Based Systems and Cyber Resilience (1/7/2024)

Attention is made to additional IACS documents on CBSs and Cyber Resilience as follows: Sec 3 Computer Based Systems includes requirements for design, construction, commissioning and maintenance of computer-based systems where they depend on software for the proper achievement of their functions. The requirements in Sec 3 focus on the functionality of the software and on the hardware supporting the software which provide control, alarm, monitoring, safety or internal communication functions subject to classification requirements. Sec 5 Cyber resilience of on-board systems and equipment includes requirements for cyber resilience for on-board systems and equipment.

IACS Recommendation 166 Recommendation on Cyber Resilience: non-mandatory recommended technical requirements that stakeholders may reference and apply to assist with the delivery of cyber resilient ships, whose resilience can be maintained throughout their service life. IACS Recommendation 166 on Cyber Resilience is intended for ships contracted for construction after its publication and may be used as a reference for ships already in service prior to its publication. For ships to which this Section applies as mandatory instrument, when both this Section and Recommendation 166 are used, should any difference in requirements addressing the same topic be found between the two instruments, the requirements in this Section are to prevail.

2 Definitions

2.1 General

2.1.1 (1/7/2024)

In the purview of this Section, the following definitions apply:

Annual survey: see Pt A, Ch 2, Sec 2, [5.1.1]

Attack surface: the set of all possible points where an unauthorized user can access a system, cause an effect on or extract data from. The attack surface comprises two categories: digital and physical. The digital attack surface encompasses all the hardware and software that connect to an organization's network. These include applications, code, ports, servers and websites. The physical attack surface comprises all endpoint devices that an attacker can

gain physical access to, such as desktop computers, hard drives, laptops, mobile phones, removable drives and carelessly discarded hardware.

Authentication: provision of assurance that a claimed characteristic of an identity is correct.

Compensating countermeasure: an alternate solution to a countermeasure employed in lieu of or in addition to inherent security capabilities to satisfy one or more security requirements.

Computer Based System (CBS): A programmable electronic device, or interoperable set of programmable electronic devices, organized to achieve one or more specified purposes such as collection, processing, maintenance, use, sharing, dissemination, or disposition of information. CBS on-board include IT and OT systems. A CBS may be a combination of subsystems connected via network. On-board CBS may be connected directly or via public means of communications (e.g. Internet) to ashore CBSs, other vessels' CBS and/or other facilities.

Cyber incident: an event resulting from any offensive cyber manoeuvre, either intentional or unintentional, that targets or affects one or more CBS onboard, which actually or potentially results in adverse consequences to an onboard system, network and computer or the information that they process, store or transmit, and which may require a response action to mitigate the consequences. Cyber incidents include unauthorized access, misuse, modification, destruction or improper disclosure of the information generated, archived or used in onboard CBS or transported in the networks connecting such systems. Cyber incidents do not include system failures.

Cyber resilience: the capability to reduce the occurrence and mitigating the effects of incidents arising from the disruption or impairment of operational technology (OT) used for the safe operation of a ship, which potentially lead to dangerous situations for human safety, safety of the vessel and/or threat to the environment.

Essential services: Services for propulsion and steering, and safety of the ship. Essential services comprise "Primary Essential Services" and "Secondary Essential Services": Primary Essential Services are those services which need to be in continuous operation to maintain propulsion and steering; Secondary Essential Services are those services which need not necessarily be in continuous operation to maintain propulsion and steering but which are necessary for maintaining the vessel's safety.

Information Technology (IT): devices, software and associated networking focusing on the use of data as information, as opposed to Operational Technology (OT).

Integrated system: a system combining a number of interacting sub-systems and/or equipment organized to achieve one or more specified purposes.

Logical network segment: The same as "Network segment", but where two or more logical network segments share the same physical components.

Network: A connection between two or more computers for the purpose of communicating data electronically by means of agreed communication protocols.

Network segment: In the context of this Section, a network segment is an OSI layer-2 Ethernet segment (a broadcast domain).

Note 1: Note on TCP/IP: Network address plan is prefixed by their IP addresses and the network mask. Communication between network segments is only possible by the use of routing service at network layer (OSI Layer 3).

Operational technology (OT): devices, sensors, software and associated networking that monitor and control onboard systems. Operational technology systems may be thought of as focusing on the use of data to control or monitor physical processes.

Physical network segment: The same as "Network segment", but where physical components are not shared by other network segments.

Protocols: a common set of rules and signals that computers on the network use to communicate. Protocols allow to perform data communication, network management and security. Onboard networks usually implement protocols based on TCP/IP stacks or various field buses.

Security zone: A collection of CBSs in the scope of applicability of this Section that meet the same security requirements. Each zone consists of a single interface or a group of interfaces, to which an access control policy is applied.

Shipowner/Company: The owner of the ship or any other organization or person, such as the manager, agent or bareboat charterer, who has assumed the responsibility for operation of the ship from the shipowner and who on assuming such responsibilities has agreed to take over all the attendant duties and responsibilities. The shipowner could be the Shipyard or systems integrator during initial construction. After vessel delivery, the shipowner may delegate some responsibilities to the vessel management company.

Special survey: Pt A, Ch 2, Sec 2, [4.1.1]

Supplier: a manufacturer or provider of hardware and/or software products, system components or equipment (hardware or software) comprising of the application, embedded devices, network devices, host devices etc. working together as system or a subsystem. The Supplier is responsible for providing programmable devices, sub-systems or systems to the System Integrator.

System Integrator: the specific person or organization responsible for the integration of systems and products provided by suppliers into the system invoked by the requirements in the ship specifications and for providing the integrated system. The system integrator may also be responsible for integration of systems in the ship. Until vessel delivery, this role is to be taken by the Shipyard unless an alternative organization is specifically contracted/assigned this responsibility.

Untrusted network: any network outside the scope of applicability of this Section.

3 Goals and organization of requirements

3.1 Primary goal

3.1.1 (1/7/2024)

The primary goal is to support safe and secure shipping, which is operationally resilient to cyber risks.

Safe and secure shipping can be achieved through effective cyber risk management system. To support safe and secure shipping resilient to cyber risk, the following sub-goals for the management of cyber risk are defined in the five functional elements listed in [3.2].

3.2 Sub-goals per functional element

3.2.1 (1/7/2024)

- a) Identify: Develop an organizational understanding to manage cybersecurity risk to onboard systems, people, assets, data, and capabilities.
- b) Protect: Develop and implement appropriate safeguards to protect the ship against cyber incidents and maximize continuity of shipping operations.
- c) Detect: Develop and implement appropriate measures to detect and identify the occurrence of a cyber incident onboard.
- d) Respond: Develop and implement appropriate measures and activities to take action regarding a detected cyber incident onboard.
- e) Recover: Develop and implement appropriate measures and activities to restore any capabilities or services necessary for shipping operations that were impaired due to a cyber incident.

These sub-goals and relevant functional elements should be concurrent and considered as parts of a single comprehensive risk management framework.

3.3 Organization of requirements

3.3.1 (1/7/2024)

The requirements are organized according to a goal-based approach. Functional/technical requirements are given for the achievement of specific sub-goals of each functional element.

The requirements are intended to allow a uniform implementation by stakeholders and to make them applicable to all types of vessels, in such a way as to enable an acceptable level of resilience and apply to all classed vessels/units regardless of operational risks and complexity of OT systems.

For each requirement, a rationale is given.

A summary of actions to be carried out and documentation to be made available is also given for each phase of the ship's life and relevant stakeholders participating to such phase.

4 Requirements

4.1 General

4.1.1 (1/7/2024)

This Article contains the requirements to be satisfied in order to achieve the primary goal defined in [3.1], organized according to the five functional elements identified in [3.2].

The requirements are to be fulfilled by the stakeholders involved in the design, building and operation of the ship. Among them, the following stakeholders can be identified (see also [2] for definitions):

- Shipowner/Company
- Systems integrator
- Supplier
- Classification Society

Whilst the above requirements may be fulfilled by these stakeholders, for the purposes of this Section, responsibility to fulfil them will lie with the stakeholder who has contracted with the Society.

4.2 Identify

4.2.1 (1/7/2024)

The requirements for the 'Identify' functional element are aimed at identifying: on one side, the CBSs onboard, their interdependencies and the relevant information flows; on the other side, the key resources involved in their management, operation and governance, their roles and responsibilities.

4.2.2 Vessel asset inventory (1/7/2024)

a) Requirement

An inventory of hardware and software (including application programs, operating systems, if any, firmware and other software components) of the CBSs in the scope of applicability of this Section and of the networks connecting such systems to each other and to other CBSs onboard or ashore is to be provided and kept up to date during the entire life of the ship.

b) Rationale

The inventory of CBSs onboard and relevant software used in OT systems, is essential for an effective management of cyber resilience of the ship, the main reason being that every CBS becomes a potential point of vulnerability. Cybercriminals can exploit unaccounted and out-of-date hardware and software to hack systems. Moreover, managing CBS assets enables Companies understand the criticality of each system to ship safety objectives.

c) Requirement details

The vessel asset inventory is to include at least the CBSs indicated in [1.4.2], if present onboard.

The inventory is to be kept updated during the entire life of the ship. Software and hardware modifications potentially introducing new vulnerabilities or modifying functional dependencies or connections among systems is to be recorded in the inventory.

If confidential information is included in the inventory (e.g. IP addresses, protocols, port numbers), special measures are to be adopted to limit the access to such information only to authorized people.

1) Hardware

For all hardware devices in the scope of applicability of this Section, the vessel asset inventory is to include at least the information in Sec 5, [3.1.2].

In addition, the vessel asset inventory may specify system category and security zone associated with the CBS.

2) Software

For all software in the scope of applicability of this Section (e.g., application program, operating system, firmware), the vessel asset inventory is to include at least the information in Sec 5, [3.1.2].

The software of the CBSs in the scope of applicability of this Section is to be maintained and updated in accordance with the shipowner's process for management of software maintenance and update policy in the Ship cyber security and resilience program, see [5.4.2].

d) Demonstration of compliance

1) Design phase

The systems integrator is to submit vessel asset inventory to the Society (ref. [5.2.4]).

The vessel asset inventory is to incorporate the asset inventories of all individual CBSs falling under the scope of this Section. Any equipment in the scope of this Section delivered by the systems integrator is also to be included in the vessel asset inventory.

2) Construction phase

The systems integrator is to keep the vessel asset inventory updated.

3) Commissioning phase

The systems integrator is to submit Ship cyber resilience test procedure (ref. [5.3.2]) and demonstrate to the Society that:

- Vessel asset inventory is updated and completed at delivery
- CBSs in the scope of applicability of this Section are correctly represented by the vessel asset inventory
- Software of the CBSs in the scope of applicability of this Section has been kept updated, e.g. by vulnerability scanning or by checking the software versions of CBSs while switched on.

4) Operation phase

For general requirements to surveys in the operation phase, see [5.4].

The shipowner is in the Ship cyber security and resilience program to describe the process of management of change (MoC) for the CBSs in the scope of applicability of this Section, addressing at least the following requirements in this Section:

- Management of change (see [5.4])

- Hardware and software modifications (see [4.2.2] c))

The shipowner is in the Ship cyber security and resilience program also to describe the management of software updates, addressing at least the following requirements in this Section:

- Vulnerabilities and cyber risks (see [4.2.2] b) and c))
- Security patching (see [4.3.7] c) 2))

First annual survey

The shipowner is to present to the Society records or other documented evidence demonstrating implementation of the Ship cyber security and resilience program, i.e., that:

- The approved management of change process has been adhered to.
- Known vulnerabilities and functional dependencies have been considered for the software in the CBSs.
- The Vessel asset inventory has been kept updated.

Subsequent annual surveys

The shipowner is upon request by the Society to demonstrate implementation of the Ship cyber security and resilience program by presenting records or other documented evidence as specified for the first annual survey.

Special Survey

The shipowner is to demonstrate to the Society the activities in section [4.2.2] d), 3) as per the Ship cyber resilience test procedure.

4.3 Protect

4.3.1 General (1/7/2024)

The requirements for the Protect functional element are aimed at the development and implementation of appropriate safeguards supporting the ability to limit or contain the impact of a potential incident.

4.3.2 Security Zones and Network Segmentation (1/7/2024)

a) Requirement

All CBSs in the scope of applicability of this Section are to be grouped into security zones with well-defined security policies and security capabilities. Security zones are either to be isolated (i.e. air gapped) or connected to other security zones or networks by means providing control of data communicated between the zones (e.g. firewalls/routers, simplex serial links, TCP/IP diodes, dry contacts, etc.)

Only explicitly allowed traffic is to traverse a security zone boundary.

b) Rationale

While networks may be protected by firewall perimeter and include Intrusion Detection Systems (IDS) or Intrusion Prevention Systems (IPS) to monitor traffic coming in, breaching that perimeter is always possible. Network segmentation makes it more difficult for an

attacker to perpetrate an attack throughout the entire network.

The main benefits of security zones and network segmentation are to reduce the extent of the attack surface, prevent attackers from achieving lateral movement through systems, and improve network performance. The concept of allocating the CBSs to security zones allows grouping the CBSs in accordance with their risk profile.

c) Requirement details

A security zone may contain multiple CBSs and networks, all of which are to comply with applicable security requirements given in this Section and Sec 5.

The network(s) of a security zone is to be logically or physically segmented from other zones or networks. See also [4.3.7] c).

CBSs providing required safety functions are to be grouped into separate security zones and are to be physically segmented from other security zones.

Navigational and communication systems are not to be in same security zone as machinery or cargo systems. If navigation and/or radiocommunication systems are approved in accordance with other equivalent standard(s) (see [1.4.2]), these systems should be in a dedicated security zone.

Wireless devices are to be in dedicated security zones. See also [4.3.6].

Systems, networks or CBSs outside the scope of applicability of this Section are considered untrusted networks and are to be physically segmented from security zones required by this Section. Alternatively, it is accepted that such systems are part of a security zone if these OT-systems meet the same requirements as demanded by the zone.

It is to be possible to isolate a security zone without affecting the primary functionality of the CBSs in the zone, see also [4.5.4].

d) Demonstration of compliance

1) Design phase

The systems integrator is to submit Zones and conduit diagram and the Cyber security design description (see [5.2.2] and [5.2.3]).

The Zones and conduit diagram are to illustrate the CBSs in the scope of applicability of this Section, how they are grouped into security zones, and include the following information:

- Clear indication of the security zones
- Simplified illustration of each CBS in scope of applicability of this Section, and indication of the security zone in which the CBS is allocated, and indication of physical location of the CBS/equipment
- Reference to the approved version of the CBS system topology diagrams provided by the suppliers (see Sec 5, [3.1.3])
- Illustration of network communication between systems in a security zone

- Illustration of any network communication between systems in different security zones (conduits)
- Illustration of any communication between systems in a security zone and untrusted networks (conduits).

The systems integrator is to include the following information in the Cyber security design description:

- A short description of the CBSs allocated to the security zone. It is to be possible to identify each CBS in the Zones and conduit diagram
- Network communication between CBSs in the same security zone. The description is to include purpose and characteristics (i.e. protocols and data flows) of the communication
- Network communication between CBSs in different security zones. The description is to include purpose and characteristics (i.e. protocols and data flows) of the communication. The description is also to include zone boundary devices and specify the traffic that is permitted to traverse the zone boundary (e.g. firewall rules)
- Any communication between CBSs in security zones and untrusted networks. The description is to include discrete signals, serial communication, and the purpose and characteristics (i.e. protocols and data flows) of IP-based network communication. The description is also to include zone boundary devices and specify the traffic that is permitted to traverse the zone boundary (e.g. firewall rules).

2) Construction phase

The systems integrator is to keep the Zones and conduit diagram updated.

3) Commissioning phase

The systems integrator is to submit Ship cyber resilience test procedure (ref. [5.3.2]) and demonstrate to the Society that:

- the security zones on board are implemented in accordance with the approved documents (i.e. zones and conduit diagram, cyber security design description, asset inventory, and relevant documents provided by the supplier). This may be done by e.g., inspection of the physical installation, network scanning and/or other methods providing the Surveyor assurance that the installed equipment is grouped in security zones according to the approved design
- security zone boundaries allow only the traffic that has been documented in the approved Cyber security description. This may be done by e.g., evaluation of firewall rules or port scanning.

4) Operation phase

For general requirements to surveys in the operation phase, see [5.4].

The shipowner is in the Ship cyber security and resilience program to describe the management of security zone boundary devices (e.g., firewalls),

addressing at least the following requirements in this Section:

- Principle of Least Functionality (see [4.3.3] a))
- Explicitly allowed traffic (see [4.3.2] a))
- Protection against denial of service (DoS) events (see [4.3.3] a))
- Inspection of security audit records (see [4.4.2], a))

First annual survey

The shipowner is to demonstrate to the Society that the Zones and conduit diagram has been kept updated and present records or other documented evidence demonstrating implementation of the Ship cyber security and resilience program, i.e., that security zone boundaries are managed in accordance with the above requirements.

Subsequent annual surveys

The shipowner is upon request by the Society to demonstrate implementation of the Ship cyber security and resilience program by presenting records or other documented evidence as specified for the first annual survey.

Special survey

The shipowner is to demonstrate to the Society the activities in [4.3.2] d), 3) as per the Ship cyber resilience test procedure.

4.3.3 Network protection safeguards (1/7/2024)

a) Requirement

Security zones are to be protected by firewalls or equivalent means as specified in [4.3.2].

The networks are also to be protected against the occurrence of excessive data flow rate and other events which could impair the quality of service of network resources.

The CBSs in scope of this Section are to be implemented in accordance with the principle of Least Functionality, i.e. configured to provide only essential capabilities and to prohibit or restrict the use of non-essential functions, where unnecessary functions, ports, protocols and services are disabled or otherwise prohibited.

b) Rationale

Network protection covers a multitude of technologies, rules and configurations designed to protect the integrity, confidentiality and availability of networks. The threat environment is always changing, and attackers are always trying to find and exploit vulnerabilities.

There are many layers to consider when addressing network protection. Attacks can happen at any layer in the network layers model, so network hardware, software and policies are to be designed to address each area.

While physical and technical security controls are designed to prevent unauthorized personnel from gaining physical access to network components and protect data stored on or in transit across the network, procedural security controls consist of security policies and processes that control user behaviour.

c) Requirement details

The design of network is to include means to meet the intended data flow through the network and minimize the risk of denial of service (DoS) and network storm/high rate of traffic. Estimation of data flow rate is at least to consider the capacity of network, data speed requirement for intended application and data format.

d) Demonstration of compliance

1) Design phase

No requirements.

2) Construction phase

No requirements.

3) Commissioning phase

The systems integrator is to submit Ship cyber resilience test procedure (ref. [5.3.2]) and demonstrate the following to the Society:

- Test denial of service (DoS) attacks targeting zone boundary protection devices, as applicable
- Test denial of service (DoS) to ensure protection against excessive data flow rate, originating from inside each network segment. Such denial of service (DoS) tests is to cover flooding of network (i.e., attempt to consume the available capacity on the network segment), and application layer attack (i.e., attempt to consume the processing capacity of selected endpoints in the network)
- Test e.g. by analytic evaluation and port scanning that unnecessary functions, ports, protocols and services in the CBSs have been removed or prohibited in accordance with hardening guidelines provided by the suppliers. See Sec 5, [5.1.8] and Sec 5, [6.3.5] g).

The second and third tests may be omitted if performed during the certification of CBSs as per [5.3.2].

4) Operation phase

For general requirements to surveys in the operation phase, see [5.4].

Special survey

Subject to modifications of the CBSs, the shipowner is to demonstrate to the Society the activities in [4.3.3] d), 3) as per the Ship cyber resilience test procedure.

4.3.4 Antivirus, antimalware, antispam and other protections from malicious code (1/7/2024)

a) Requirement

CBSs in the scope of applicability of this Section are to be protected against malicious code such as viruses, worms, trojan horses, spyware, etc.

b) Rationale

A virus or any unwanted program that enters a user's system without his/her knowledge can self-replicate and spread, perform unwanted and malicious actions that end up affecting the system's performance, user's data/files, and/or circumvent data security measures.

Antivirus, antimalware, antispam software will act as a closed door with a security guard fending off the malicious intruding viruses performing a prophylactic function. It detects potential virus and then works to remove it, mostly before the virus gets to harm the system.

Common means for malicious code to enter CBSs are electronic mail, electronic mail attachments, websites, removable media (for example, universal serial bus (USB) devices, diskettes or compact disks), PDF documents, web services, network connections and infected laptops.

c) Requirement details

Malware protection is to be implemented on CBSs in the scope of applicability of this Section. On CBSs having an operating system for which industrial-standard anti-virus and anti-malware software is available and maintained up-to-date, anti-virus and/or anti-malware software are to be installed, maintained and regularly updated, unless the installation of such software impairs the ability of CBS to provide the functionality and level of service required (e.g. for Cat.II and Cat.III CBSs performing real-time tasks).

On CBSs where anti-virus and anti-malware software cannot be installed, malware protection is to be implemented in the form of operational procedures, physical safeguards, or according to manufacturer's recommendations.

d) Demonstration of compliance

1) Design phase

The systems integrator is to include the following information in the Cyber security design description:

- For each CBS, summary of the approved mechanisms provided by the supplier for protection against malicious code or unauthorized software
- For CBSs with anti-malware software, information about how to keep the software updated
- Any operational conditions or necessary physical safeguards to be implemented in the shipowner's management system.

2) Construction phase

The systems integrator is to ensure that malware protection is kept updated during the construction phase.

3) Commissioning phase

The systems integrator is to submit Ship cyber resilience test procedure (ref. [5.3.2]) and demonstrate the following to the Society:

- Approved anti-malware software or other compensating countermeasures is effective (test e.g., with a trustworthy anti-malware test file).

The above tests may be omitted if performed during the certification of CBSs as per [5.3.2].

4) Operation phase

For general requirements to surveys in the operation phase, see [5.4].

The shipowner is in the Ship cyber security and resilience program to describe the management of malware protection, addressing at least the following requirements in this Section:

- Maintenance/update (see [4.3.4] c))
- Operational procedures, physical safeguards (see [4.3.4] c))
- Use of mobile, portable, removable media (see [4.3.5] c), 4) and [4.3.8] c))
- Access control (see [4.3.5])

First annual survey

The shipowner is to present to the Society records or other documented evidence demonstrating implementation of the Ship cyber security and resilience program, i.e., that:

- Any anti-malware software has been maintained and updated
- Procedures for use of portable, mobile or removable devices have been followed
- Policies and procedures for access control have been followed
- Physical safeguards are maintained.

Subsequent annual surveys

The shipowner is upon request by the Society to demonstrate implementation of the Ship cyber security and resilience program by presenting records or other documented evidence as specified for the first annual survey.

Special survey

The shipowner is to demonstrate to the Society the activities in [4.3.4] d), 3) as per the Ship cyber resilience test procedure.

4.3.5 Access control (1/7/2024)

a) Requirement

CBSs and networks in the scope of applicability of this Section are to provide physical and/or logical/digital measures to selectively limit the ability and means to communicate with or otherwise interact with the system itself, to use system resources to handle information, to gain knowledge of the information the system contains or to control system components and functions. Such measures are to be such as not to hamper the ability of authorized personnel to access CBS for their level of access according to the least privilege principle.

b) Rationale

Attackers may attempt to access the ship's systems and data from either onboard the ship, within the company, or remotely through connectivity with the internet. Physical and logical access controls to cyber assets, networks etc. should then be implemented to ensure safety of the ship and its cargo.

Physical threats and relevant countermeasures are also considered in the ISPS Code. Similarly, the ISM Code contains guidelines to ensure safe operation of ships and protection of the environment. Implementation of ISPS and ISM Codes may imply inclusion in the Ship Security Plan (SSP) and Safety Management System

(SMS) of instructions and procedures for access control to safety critical assets.

c) **Requirement details**

Access to CBSs and networks in the scope of applicability of this Section and all information stored on such systems are only to be allowed to authorized personnel, based on their need to access the information as a part of their responsibilities or their intended functionality.

1) **Physical access control**

CBSs of Cat.II and Cat.III are generally to be located in rooms that can normally be locked or in controlled space to prevent unauthorized access, or are to be installed in lockable cabinets or consoles. Such locations or lockable cabinets/consoles are to be however easy to access to the crew and various stakeholders who need to access to CBSs for installation, integration, operation, maintenance, repair, replacement, disposal etc. so as not to hamper effective and efficient operation of the ship.

2) **Physical access control for visitors**

Visitors such as authorities, technicians, agents, port and terminal officials, and shipowner representatives are to be restricted regarding access to CBSs onboard whilst on board, e.g. by allowing access under supervision.

3) **Physical access control of network access points**

Access points to onboard networks connecting Cat.II and/or Cat.III CBSs are to be physically and/or logically blocked except when connection occurs under supervision or according to documented procedures, e.g. for maintenance.

Independent computers isolated from all onboard networks, or other networks, such as dedicated guest access networks, or networks dedicated to passenger recreational activities, are to be used in case of occasional connection requested by a visitor (e.g. for printing documents).

4) **Removable media controls**

A policy for the use of removable media devices is to be established, with procedures to check removable media for malware and/or validate legitimate software by digital signatures and watermarks and scan prior to permitting the uploading of files onto a ship's system or downloading data from the ship's system. See also [4.3.8].

5) **Management of credentials**

CBSs and relevant information are to be protected with file system, network, application, or database specific Access Control Lists (ACL). Accounts for onboard and onshore personnel are to be left active only for a limited period according to the role and responsibility of the account holder and are to be removed when no longer needed.

Note 1: CBSs are to identify and authenticate human users as per item No.1 in Sec 5, Tab 1. In other words, it is not necessary to "uniquely" identify and authenticate all human users

Onboard CBSs are to be provided with appropriate access control that fits to the policy of their Security Zone but does not adversely affect their primary purpose. CBSs which require strong access control may need to be secured using a strong encryption key or multi-factor authentication.

Administrator privileges are to be managed in accordance with the policy for access control, allowing only authorized and appropriately trained personnel full access to the CBS, who as part of their role in the company or onboard need to log on to systems using these privileges.

6) **Least privilege principle**

Any human user allowed to access CBS and networks in the scope of applicability of this Section is to have only the bare minimum privileges necessary to perform its function.

The default configuration for all new account privileges is to be set as low as possible. Wherever possible, raised privileges are to be restricted only to moments when they are needed, e.g. using only expiring privileges and one-time-use credentials. Accumulation of privileges over time is to be avoided, e.g. by regular auditing of user accounts.

d) **Demonstration of compliance**

1) **Design phase**

The systems integrator is to include the following information in the Cyber security design description:

- Location and physical access controls for the CBSs. Devices providing Human Machine Interface (HMI) for operators needing immediate access need not enforce user identification and authentication provided they are located in an area with physical access control. Such devices are to be specified.

2) **Construction phase**

The systems integrator is to prevent unauthorised access to the CBSs during the construction phase.

3) **Commissioning phase**

The systems integrator is to submit Ship cyber resilience test procedure (ref. [5.3.2]) and demonstrate the following to the Society:

- Components of the CBSs are located in areas or enclosures where physical access can be controlled to authorised personnel
- User accounts are configured according to the principles of segregation of duties and least privilege and that temporary accounts have been removed (may be omitted based on certification of CBSs as per [5.3.2]).

4) **Operation phase**

For general requirements to surveys in the operation phase, see [5.4].

The shipowner is in the Ship cyber security and resilience program to describe the management of logical and physical access, addressing at least the following requirements in this Section:

- Physical access control (see [4.3.5] c), 1))

- Physical access control for visitors (see [4.3.4] d), 2))
- Physical access control of network access points (see [4.3.5] c), 3))
- Management of credentials (see [4.3.5] c), 5))
- Least privilege policy (see [4.3.5] c), 6))

The shipowner is in the Ship cyber security and resilience program to describe the management of confidential information, addressing at least the following requirements in this Section:

- Confidential information (see [4.2.2] c))
- Information allowed to authorized personnel (see [4.3.5] c))
- Information transmitted on the wireless network (see [4.3.6] c))

First annual survey

The shipowner is to present to the Society records or other documented evidence demonstrating implementation of the Ship cyber security and resilience program, i.e., that:

- Personnel are authorized to access the CBSs in accordance with their responsibilities
- Only authorised devices are connected to the CBSs
- Visitors are given access to the CBSs according to relevant policies and procedures
- Physical access controls are maintained and applied
- Credentials, keys, secrets, certificates, relevant CBS documentation, and other sensitive information is managed and kept confidential according to relevant policies and procedures.

Subsequent annual surveys

The shipowner is upon request by the Society to demonstrate implementation of the Ship cyber security and resilience program by presenting records or other documented evidence as specified for the first annual survey.

4.3.6 Wireless communication (1/7/2024)

a) Requirement

Wireless communication networks in the scope of this Section are to be designed, implemented and maintained to ensure that:

- Cyber incidents will not propagate to other control systems
- Only authorised human users will gain access to the wireless network
- Only authorised processes and devices will be allowed to communicate on the wireless network
- Information in transit on the wireless network cannot be manipulated or disclosed.

b) Rationale

Wireless networks give rise to additional or different cybersecurity risks than wired networks. This is mainly due to less physical protection of the devices and the use of the radio frequency communication.

Inadequate physical access control may lead to unauthorised personnel gaining access to the physical devices, which in turn could lead to circumventing logical access restrictions or deployment of rogue devices on the network.

Signal transmission by radio frequency introduces risks related to jamming as well as eavesdropping which in turn could cater for attacks such as Piggybacking or Evil twin attacks (see <https://us-cert.cisa.gov/ncas/tips/ST05-003>).

c) Requirement details

Cryptographic mechanisms such as encryption algorithms and key lengths in accordance with industry standards and best practices are to be applied to ensure integrity and confidentiality of the information transmitted on the wireless network.

Devices on the wireless network are only to communicate on the wireless network (i.e. they are not to be "dual-homed").

Wireless networks are to be designed as separate segments in accordance with [4.3.2] and protected as per [4.3.3].

Wireless access points and other devices in the network are to be installed and configured such that access to the network can be controlled.

The network device or system utilizing wireless communication is to provide the capability to identify and authenticate all users (humans, software processes or devices) engaged in that communication.

d) Demonstration of compliance

1) Design phase

The systems integrator is to include the following information in the Cyber security design description:

- Description of wireless networks in the scope of applicability of this Section and how these are implemented as separate security zones. The description is to include zone boundary devices and specify the traffic that is permitted to traverse the zone boundary (e.g. firewall rules).

2) Construction phase

The systems integrator is to prevent unauthorised access to the wireless networks during the construction phase.

3) Commissioning phase

The systems integrator is to submit Ship cyber resilience test procedure (ref. [5.3.2]) and demonstrate the following to the Society:

- Only authorised devices can access the wireless network.
- Secure wireless communication protocol is used as per approved documentation by the respective supplier (demonstrate e.g. by use of a network protocol analyser tool).

The above tests may be omitted if performed during the certification of CBSs as per [5.3.2].

4) Operation phase

For general requirements to surveys in the operation phase, see [5.4].

Special survey

Subject to modifications of the wireless networks in the scope of applicability of this Section, the shipowner is to demonstrate to the Society the activities in [4.3.6] d), 3) as per the Ship cyber resilience test procedure.

4.3.7 Remote access control and communication with untrusted networks (1/7/2024)**a) Requirement**

CBSs in scope of this Section are to be protected against unauthorized access and other cyber threats from untrusted networks.

b) Rationale

Onboard CBSs have become increasingly digitalized and connected to the internet to perform a wide variety of legitimate functions. The use of digital systems to monitor and control onboard CBSs makes them vulnerable to cyber incidents. Attackers may attempt to access onboard CBSs through connectivity with the internet and may be able to make changes that affect a CBS's operation or even achieve full control of the CBS, or attempt to download information from the ship's CBS. In addition, since use of legacy IT and OT systems that are no longer supported and/or rely on obsolete operating systems affects cyber resilience, special care should be put to relevant hardware and software installations on board to help maintain a sufficient level of cyber resilience when such systems can be remotely accessed, also keeping in mind that not all cyber incidents are a result of a deliberate attack.

c) Requirement details

User's manual is to be delivered for control of remote access to onboard IT and OT systems. Clear guidelines are to identify roles and permissions with functions.

For CBSs in the scope of applicability of this Section, no IP address is to be exposed to untrusted networks.

Communication with or via untrusted networks requires secure connections (e.g. tunnels) with endpoint authentication, protection of integrity and authentication and encryption at network or transport layer. Confidentiality is to be ensured for information that is subject to read authorization.

1) Design

CBSs in the scope of applicability of this Section are to:

- have the capability to terminate a connection from the onboard connection endpoint. Any remote access is not to be possible until explicitly accepted by a responsible role on board
- be capable of managing interruptions during remote sessions so as not to compromise the safe functionality of OT systems or the integrity and availability of data used by OT systems
- provide a logging function to record all remote access events and retain for a period of time sufficient for offline review of remote

connections, e.g. after detection of a cyber incident.

2) Additional requirements for remote maintenance

When remote access is used for maintenance, the following requirements are to be complied with in addition to those in [4.3.7] c), 1):

- Documentation is to be provided to show how they connect and integrate with the shore side
- Security patches and software updates are to be tested and evaluated before they are installed to ensure they are effective and do not result in side effects or cyber events that cannot be tolerated. A confirmation report from the software supplier towards above is to be obtained, prior to undertaking remote update
- Suppliers are to provide plans for and make security updates available to the shipowner, see Sec 5, [5.1.3], [5.1.4] and [5.1.5]
- At any time, during remote maintenance activities, authorized personnel is to have the possibility to interrupt and abort the activity and roll back to a previous safe configuration of the CBS and systems involved
- Multi-factor authentication is required for any access by human users to CBS's in scope from an untrusted network
- After a configurable number of failed remote access attempts, the next attempt is to be blocked for a predetermined length of time
- If the connection to the remote maintenance location is disrupted for some reason, access to the system is to be terminated by an automatic logout function.

d) Demonstration of compliance**1) Design phase**

The systems integrator is to include the following information in the Cyber security design description:

- Identification of each CBS in the scope of applicability of this Section that can be remotely accessed or that otherwise communicates through the security zone boundary with untrusted networks
- For each CBS, a description of compliance with requirements in [4.3.7], c), as applicable.

2) Construction phase

The systems integrator is to ensure that any communication with untrusted networks is only temporarily enabled and used in accordance with the requirements of this Section.

3) Commissioning phase

The systems integrator is to submit Ship cyber resilience test procedure (ref. [5.3.2]) and demonstrate the following to the Society:

- Communication with untrusted networks is secured in accordance with Sec 5, [4.3] and that the communication protocols cannot be negotiated to a less secure version (demonstrate e.g., by use of a network protocol analyzer tool).

- Remote access requires multifactor authentication of the remote user
- A limit of unsuccessful login attempts is implemented, and that a notification message is provided for the remote user before session is established
- Remote connections are to be explicitly accepted by responsible personnel on board
- Remote sessions can be manually terminated by personnel on board or that the session will automatically terminate after a period of inactivity
- Remote sessions are logged (see Sec 5, Tab 1, item 13)
- Instructions or procedures are provided by the respective product suppliers (see Sec 5, [3.1.4]).

4) Operation phase

For general requirements to surveys in the operation phase, see [5.4].

The shipowner is in the Ship cyber security and resilience program to describe the management of remote access and communication with/via untrusted networks, addressing at least the following requirements in this Section:

- User's manual (see [4.3.7] c))
- Roles and permissions (see [4.3.7] c))
- Patches and updates (see [4.3.7] c), 2))
- Confirmation prior to undertaking remote software update (see [4.3.7] c), 2))
- Interrupt, abort, roll back (see [4.3.7] c), 2))

First annual survey

The shipowner is to present to the Society records or other documented evidence demonstrating implementation of the Ship cyber security and resilience program, i.e., that:

- Remote access sessions have been recorded or logged and carried out as per relevant policies and user manuals
- Installation of security patches and other software updates have been carried out in accordance with Management of change procedures and in cooperation with the supplier.

Annual survey

The shipowner is upon request by the Society to demonstrate implementation of the Ship cyber security and resilience program by presenting records or other documented evidence as specified for the first annual survey.

Special survey

The shipowner is to demonstrate to the Society the activities in [4.3.7] d), 3) as per the Ship cyber resilience test procedure.

4.3.8 Use of Mobile and Portable Devices (1/7/2024)

a) Requirement

The use of mobile and portable devices in CBSs in the scope of applicability of this Section is to be limited to only necessary activities and be controlled in accordance with Sec 5, Tab 1, item 10. For any CBS that cannot fully meet these requirements, the interface ports are to be physically blocked.

b) Rationale

It is generally known that CBSs can be impaired due to malware infection via a mobile or a portable device. Therefore, connection of mobile and portable devices should be carefully considered. In addition, mobile equipment that is required to be used for the operation and maintenance of the ship should be under the control of the shipowner.

c) Requirement details

Mobile and portable devices are only to be used by authorised personnel. Only authorised devices may be connected to the CBSs. All use of such devices is to be in accordance with the shipowner's policy for use of mobile and portable devices, taking into account the risk of introducing malware in the CBS.

d) Demonstration of compliance

1) Design phase

The systems integrator is to include the following information in the Cyber security design description:

- Any CBSs in the scope of applicability that do not meet the requirements in Sec 5, Tab 1, item 10, i.e., that are to have protection of interface ports by physical means such as port blockers.

2) Construction phase

The systems integrator is to ensure that use of physical interface ports in the CBSs is controlled in accordance with Sec 5, Tab 1, item 10, and that any use of such devices follows procedures to prevent malware from being introduced in the CBS.

3) Commissioning phase

The systems integrator is to submit Ship cyber resilience test procedure (ref. [5.3.2]) and demonstrate to the Society that capabilities to control use of mobile and portable devices are implemented correctly, the following countermeasures are to be demonstrated as relevant:

- Use of mobile and portable devices is restricted to authorised users
- Interface ports can only be used by specific device types
- Files cannot be transferred to the system from such devices
- Files on such devices will not be automatically executed (by disabling autorun)
- Network access is limited to specific MAC or IP addresses
- Unused interface ports are disabled
- Unused interface ports are physically blocked

4) Operation phase

For general requirements to surveys in the operation phase, see [5.4].

The shipowner is in the Ship cyber security and resilience program to describe the management of mobile and portable devices, addressing at least the following requirements in this Section:

- Policy and procedures (see [4.3.5] c), 4))
- Physical block of interface ports (see [4.3.8] a))
- Use by authorized personnel (see [4.3.8] c))
- Connect only authorized devices (see [4.3.8] c))
- Consider risk of introducing malware (see [4.3.8] c))

First annual survey

The shipowner is to present to the Society records or other documented evidence demonstrating implementation of the Ship cyber security and resilience program, i.e., that:

- The use of mobile, portable or removable media is restricted to authorised personnel and follows relevant policies and procedures
- Only authorised devices are connected to the CBSs
- Means to restrict use of physical interface ports are implemented as per approved design documentation.

Subsequent annual survey

The shipowner is upon request by the Society to demonstrate implementation of the Ship cyber security and resilience program by presenting records or other documented evidence as specified for the first annual survey.

Special survey

The shipowner is to demonstrate to the Society the activities in [4.3.8] d), 3) as per the Ship cyber resilience test procedure.

4.4 Detect

4.4.1 General (1/7/2024)

The requirements for the Detect functional element are aimed at the development and implementation of appropriate means supporting the ability to reveal and recognize anomalous activity on CBSs and networks onboard and identify cyber incidents.

4.4.2 Network operation monitoring (1/7/2024)

a) Requirement

Networks in scope of this Section are to be continuously monitored, and alarms are to be generated if malfunctions or reduced/degraded capacity occurs.

b) Rationale

Cyber-attacks are becoming increasingly sophisticated, and attacks that target vulnerabilities that were unknown at the time of construction could result in incidents where the vessel is ill-prepared for the threat. To enable an early response to attacks targeting these types of unknown vulnerabilities, technology capable of

detecting unusual events is required. A monitoring system that can detect anomalies in networks and that can use post-incident analysis provides the ability to appropriately respond and further recover from a cyber event.

c) Requirement details

Measures to monitor networks in the scope of applicability of this Section are to have the following capabilities:

- Monitoring and protection against excessive traffic
- Monitoring of network connections
- Monitoring and recording of device management activities
- Protection against connection of unauthorized devices
- Generate alarm if utilization of the network's bandwidth exceeds a threshold specified as abnormal by the supplier. See Sec 3, [7.3.1].

Intrusion detection systems (IDS) may be implemented, subject to the following:

- The IDS is to be qualified by the supplier of the respective CBS
- The IDS is to be passive and not activate protection functions that may affect the performance of the CBS
- Relevant personnel should be trained and qualified for using the IDS.

d) Demonstration of compliance

1) Design phase

No requirements.

2) Construction phase

No requirements.

3) Commissioning phase

The systems integrator is to specify in the Ship cyber resilience test procedure and demonstrate to the Society the network monitoring and protection mechanisms in the CBSs.

- Test that disconnected network connections will activate alarm and that the event is recorded.
- Test that abnormally high network traffic is detected, and that alarm and audit record is generated. This test may be carried on together with the test in [4.5.5] d), 3).
- Demonstrate that the CBS will respond in a safe manner to network storm scenarios, considering both unicast and broadcast messages (see also [4.3.3] d), 3))
- Demonstrate generation of audit records (logging of security-related events)
- If Intrusion detection systems are implemented, demonstrate that this is passive and will not activate protection functions that may affect intended operation of the CBSs.

The above tests may be omitted if performed during the certification of CBSs as per [5.3.2].

Any Intrusion detection systems in the CBSs in scope of applicability to be implemented is to be subject to verification by the Society. Relevant documentation

is to be submitted for approval, and survey/tests are to be carried out on board.

4) **Operation phase**

For general requirements to surveys in the operation phase, see [5.4].

The shipowner is in the Ship cyber security and resilience program to describe the management activities to detect anomalies in the CBSs and networks, addressing at least the following requirements in this Section:

- Reveal and recognize anomalous activity (see [4.4])
- Inspection of security audit records (see [4.4.2] c))
- Instructions or procedures to detect incidents (see [4.5.2] a))

The above activities may be addressed together with incident response in [4.5.2].

First annual survey

The shipowner is to present to the Society records or other documented evidence demonstrating implementation of the Ship cyber security and resilience program, i.e., that:

- The CBSs are routinely monitored for anomalies by inspection of security audit records and investigation of alerts in the CBSs.

Subsequent annual surveys

The shipowner is upon request by the Society to demonstrate implementation of the Ship cyber security and resilience program by presenting records or other documented evidence as specified for the first annual survey.

Special survey

Subject to modifications of the CBSs, the shipowner is to demonstrate to the Society the activities in [4.4.2] d), 3) as per the Ship cyber resilience test procedure.

4.4.3 Verification and diagnostic functions of CBS and networks (1/7/2024)

a) **Requirement**

CBSs and networks in the scope of applicability of this Section are to be capable to check performance and functionality of security functions required by this Section. Diagnostic functions are to provide adequate information on CBSs integrity and status for the use of the intended user and means for maintaining their functionality for a safe operation of the ship.

b) **Rationale**

The ability to verify intended operation of the security functions is important to support management of cyber resilience in the lifetime of the ship. Tools for diagnostic functions may comprise automatic or manual functions such as self-diagnostics capabilities of each device, or tools for network monitoring (such as ping, traceroute, ipconfig, netstat, nslookup, Wireshark, nmap, etc.).

It should be noted however that execution of diagnostic functions may sometimes impact the operational performance of the CBS.

c) **Requirement details**

CBSs and networks' diagnostics functionality is to be available to verify the intended operation of all required security functions during test and maintenance phases of the ship.

d) **Demonstration of compliance**

1) **Design phase**

No requirements.

2) **Construction phase**

No requirements.

3) **Commissioning phase**

The systems integrator is to submit Ship cyber resilience test procedure (ref. [5.3.2]) and demonstrate to the Society the effectiveness of the procedures for verification of security functions provided by the suppliers.

The above tests may be omitted if performed during the certification of CBSs as per [5.3.2].

4) **Operation phase**

For general requirements to surveys in the operation phase, see [5.4].

The shipowner is in the Ship cyber security and resilience program to describe the management activities to verify correct operation of the security functions in the CBSs and networks, addressing at least the following requirements in this Section:

- Test and maintenance periods (see [4.4.3] c))
- Periodic maintenance (see [5.4.4]).

First annual survey

The shipowner is to present to the Society records or other documented evidence demonstrating implementation of the Ship cyber security and resilience program, i.e., that:

- The security functions in the CBSs are periodically tested or verified.

Subsequent annual surveys

The shipowner is upon request by the Society to demonstrate implementation of the Ship cyber security and resilience program by presenting records or other documented evidence as specified for the first annual survey.

4.5 Respond

4.5.1 General (1/7/2024)

The requirements for the Respond functional element are aimed at the development and implementation of appropriate means supporting the ability to minimize the impact of cyber incidents, containing the extension of possible impairment of CBSs and networks onboard.

4.5.2 Incident response plan (1/7/2024)

a) **Requirement**

An incident response plan is to be developed by the shipowner covering relevant contingencies and specifying how to react to cyber security incidents. The Incident response plan is to contain documentation of a predetermined set of instructions or procedures to

detect, respond to, and limit consequences of incidents against CBSs in the scope of applicability of this Section.

b) **Rationale**

An incident response plan is an instrument aimed to help responsible persons respond to cyber incidents. As such, the Incident response plan is as effective as it is simple and carefully designed. When developing the Incident response plan, it is important to understand the significance of any cyber incident and prioritize response actions accordingly.

Means for maintaining as much as possible the functionality and a level of service for a safe operation of the ship, e.g. transfer active execution to a standby redundant unit, should also be indicated. Designated personnel ashore should be integrated with the ship in the event of a cyber incident.

c) **Requirement details**

The various stakeholders involved in the design and construction phases of the ship are to provide information to the shipowner for the preparation of the Incident Response Plan to be placed onboard at the first annual Survey. The Incident Response Plan is to be kept up-to-date (e.g. upon maintenance) during the operational life of the ship.

The Incident response plan is to provide procedures to respond to detected cyber incidents on networks by notifying the proper authority, reporting needed evidence of the incidents and taking timely corrective actions, to limit the cyber incident impact to the network segment of origin.

The incident response plan is, as a minimum, to include the following information:

- Breakpoints for the isolation of compromised systems
- A description of alarms and indicators signalling detected ongoing cyber events or abnormal symptoms caused by cyber events
- A description of expected major consequences related to cyber incidents
- Response options, prioritizing those which do not rely on either shut down or transfer to independent or local control, if any
- Independent and local control information for operating independently from the system that failed due to the cyber incident, as applicable

The Incident response plan is to be kept in hard copy in the event of complete loss of electronic devices enabling access to it.

d) **Demonstration of compliance**

1) **Design phase**

The systems integrator is to include the following information in the Cyber security design description:

- References to information provided by the suppliers (see Sec 5, [3.1.9]) that may be applied by the shipowner to establish plans for incident response.

2) **Construction phase**

No requirements.

3) **Commissioning phase**

No requirements.

4) **Operation phase**

For general requirements to surveys in the operation phase, see [5.4].

The shipowner is in the Ship cyber security and resilience program to describe incident response plans. The plans are to cover the CBSs in scope of applicability of this Section and are to address at least the following requirements in this Section:

- Description of who, when and how to respond to cyber incidents in accordance with requirements of [4.5.2]
- Procedures or instructions for local/manual control in accordance with requirements in [4.5.3]
- Procedures or instructions for isolation of security zones in accordance with requirements in [4.5.4]
- Description of expected behaviour of the CBSs in the event of cyber incidents in accordance with requirements in [4.5.5].

First annual survey

The shipowner is to present to the Society records or other documented evidence demonstrating implementation of the Ship cyber security and resilience program, i.e., that:

- The incident response plans are available for the responsible personnel onboard
- Procedures or instructions for local/manual controls are available for responsible personnel onboard
- Procedures or instructions for disconnection/isolation of security zones are available for responsible personnel onboard
- Any cyber incidents have been responded to in accordance with the incident response plans.

Subsequent annual surveys

The shipowner is upon request by the Society to demonstrate implementation of the Ship cyber security and resilience program by presenting records or other documented evidence as specified for the first annual survey.

4.5.3 Local, independent and/or manual operation (1/7/2024)

a) **Requirement**

Any CBS needed for local backup control as required by SOLAS II-1 Regulation 31 is to be independent of the primary control system. This includes also necessary Human Machine Interface (HMI) for effective local operation.

b) **Rationale**

Independent local controls of machinery and equipment needed to maintain safe operation is a fundamental principle for manned vessels. The objective of this requirement has traditionally been to ensure that personnel can cope with failures and other incidents by

performing manual operations in close vicinity of the machinery. Since incidents caused by malicious cyber events should also be considered, this principle of independent local control is no less important.

c) Requirement details

The CBS for local control and monitoring is to be self-contained and not depend on communication with other CBS for its intended operation.

If communication to the remote control system or other CBS's is arranged by networks, segmentation and protection safeguards as described in [4.3.2] and [4.3.3] are to be implemented. This implies that the local control and monitoring system is to be considered a separate security zone. Notwithstanding the above, special considerations can be given to CBSs with different concepts on case by case basis

The CBS for local control and monitoring is otherwise to comply with requirements in this Section.

d) Demonstration of compliance

1) Design phase

The systems integrator is to include the following information in the Cyber security design description:

- Description of how the local controls specified in SOLAS II-1 Reg.31 are protected from cyber incidents in any connected remote or automatic control systems.

2) Construction phase

No requirements.

3) Commissioning phase

The systems integrator is to submit Ship cyber resilience test procedure (ref. [5.3.2]) and demonstrate to the Society that the required local controls in the scope of applicability of this Section needed for safety of the ship can be operated independently of any remote or automatic control systems. The tests are to be carried out by disconnecting all networks from the local control system to other systems/devices.

The above tests may be omitted if performed during the certification of CBSs as per [5.3.2].

4) Operation phase

For general requirements to surveys in the operation phase, see [5.4].

Special survey

Subject to modifications of the CBSs, the shipowner is to demonstrate to the Society the activities in [4.5.3] d), 3) as per the Ship cyber resilience test procedure.

4.5.4 Network isolation (1/7/2024)

a) Requirement

It is to be possible to terminate network-based communication to or from a security zone.

b) Rationale

In the event that a security breach has occurred and is detected, it is likely that the incident response plan includes actions to prevent further propagation and

effects of the incident. Such actions could be to isolate network segments and control systems supporting essential functions.

c) Requirement details

Where the Incident Response Plan indicates network isolation as an action to be done, it is to be possible to isolate security zones according to the indicated procedure, e.g. by operating a physical ON/OFF switch on the network device or similar actions such as disconnecting a cable to the router/firewall. There are to be available instructions and clear marking on the device that allows the personnel to isolate the network in an efficient manner.

Individual system's data dependencies that may affect function and correct operation, including safety, are to be identified, clearly showing where systems are to have compensations for data or functional inputs if isolated during a contingency.

d) Demonstration of compliance

1) Design phase

The systems integrator is to include the following information in the Cyber security design description:

- specification of how to isolate each security zone from other zones or networks. The effects of such isolation are also to be described, demonstrating that the CBSs in a security zone do not rely on data transmitted by IP-networks from other zones or networks.

2) Construction phase

No requirements.

3) Commissioning phase

The systems integrator is to submit Ship cyber resilience test procedure (ref. [5.3.2]) and demonstrate to the Society by disconnecting all networks traversing security zone boundaries, that the CBSs in the security zone will maintain adequate operational functionality without network communication with other security zones or networks.

The above tests may be omitted if performed during the certification of CBSs as per [5.3.2].

4) Operation phase

For general requirements to surveys in the operation phase, see [5.4].

Special survey

Subject to modifications of the CBSs, the shipowner is to demonstrate to the Society the activities in [4.5.4] d), 3) as per the Ship cyber resilience test procedure.

4.5.5 Fallback to a minimal risk condition (1/7/2024)

a) Requirement

In the event of a cyber incident impairing the ability of a CBS or network in the scope of applicability of this Section to provide its intended service, the affected system or network is to fall back to a minimal risk condition, i.e. bring itself in a stable, stopped condition to reduce the risk of possible safety issues.

b) **Rationale**

The ability of a CBS and integrated systems to fallback to one or more minimal risk conditions to be reached in case of unexpected or unmanageable failures or events is a safety measure aimed to keep the system in a consistent, known and safe state.

Fallback to a minimal risk condition usually implies the capability of a system to abort the current operation and signal the need for assistance, and may be different depending on the environmental conditions, the voyage phase of the ship (e.g. port depart/arrival vs. open sea passage) and the events occurred.

c) **Requirement details**

As soon as a cyber incident affecting the CBS or network is detected, compromising the system's ability to provide the intended service as required, the system is to fall back to a condition in which a reasonably safe state can be achieved. Fall-back actions may include:

- bringing the system to a complete stop or other safe state
- disengaging the system
- transferring control to another system or human operator
- other compensating actions.

Fall-back to minimum risk conditions is to occur in a time frame adequate to keep the ship in a safe condition.

The ability of a system to fall back to a minimal risk condition is to be considered from the design phase by the supplier and the systems integrator.

d) **Demonstration of compliance**1) **Design phase**

The systems integrator is to include the following information in the Cyber security design description:

- Specification of safe state for the control functions in the CBSs in the scope of applicability of this Section.

2) **Construction phase**

No requirements.

3) **Commissioning phase**

The systems integrator is to submit Ship cyber resilience test procedure (ref. [5.3.2]) and demonstrate to the Society that CBSs in the scope of applicability of this Section respond to cyber incidents in a safe manner (as per [4.5.5] d), 1)), e.g. by maintaining its outputs to essential services and allowing operators to carry out control and monitoring functions by alternative means. The tests are at least to include denial of service (DoS) attacks and may be done together with related test in [4.4.2] d), 3).

The above tests may be omitted if performed during the certification of CBSs as per [5.3.2].

4) **Operation phase**

For general requirements to surveys in the operation phase, see [5.4].

Special survey

Subject to modifications of the CBSs, the shipowner is to demonstrate to the Society the activities in [4.5.5] d), 3) as per the Ship cyber resilience test procedure.

4.6 Recover**4.6.1 General (1/7/2024)**

The requirements for the Recover functional element are aimed at the development and implementation of appropriate means supporting the ability to restore CBSs and networks onboard affected by cyber incidents.

4.6.2 Recovery plan (1/7/2024)a) **Requirement**

A recovery plan is to be made by the shipowner to support restoring CBSs under the scope of applicability of this Section to an operational state after a disruption or failure caused by a cyber incident. Details of where assistance is available and by whom are to be part of the recovery plan.

b) **Rationale**

Incident response procedures are an essential part of system recovery. Responsible personnel should consider carefully and be aware of the implications of recovery actions (such as wiping of drives) and execute them carefully.

It should be noted, however, that some recovery actions may result in the destruction of evidence that could provide valuable information on the causes of an incident.

Where appropriate, external cyber incident response support should be obtained to assist in preservation of evidence whilst restoring operational capability.

c) **Requirement details**

The various stakeholders involved in the design and construction phases of the ship are to provide information to the shipowner for the preparation of the recovery plan to be placed onboard at the first annual Survey. The recovery plan is to be kept up-to-date (e.g. upon maintenance) during the operational life of the ship.

Recovery plans are to be easily understandable by the crew and external personnel and include essential instructions and procedures to ensure the recovery of a failed system and how to get external assistance if the support from ashore is necessary. In addition, software recovery medium or tools essential for recovery on board are to be available.

When developing recovery plans, the various systems and subsystems involved are to be specified. The following recovery objectives are also to be specified:

- System recovery: methods and procedures to recover communication capabilities are to be specified in terms of Recovery Time Objective (RTO). This is defined as the time required to recover the required communication links and processing capabilities
- Data recovery: methods and procedures to recover data necessary to restore safe state of OT systems

and safe ship operation are to be specified in terms of Recovery Point Objective (RPO). This is defined as the longest period of time for which an absence of data can be tolerated.

Once the recovery objectives are defined, a list of potential cyber incidents are to be created, and the recovery procedure developed and described. Recovery plans are to include, or refer to the following information

- Instructions and procedures for restoring the failed system without disrupting the operation from the redundant, independent or local operation
- Processes and procedures for the backup and secure storage of information
- Complete and up-to-date logical network diagram
- The list of personnel responsible for restoring the failed system
- Communication procedure and list of personnel to contact for external technical support including system support vendors, network administrators, etc
- Current configuration information for all components.

The operation and navigation of the ship is to be prioritized in the plan in order to help ensure the safety of onboard personnel.

Recovery plans in hard copy onboard and ashore are to be available to personnel responsible for cyber security and who are tasked with assisting in cyber incidents.

d) **Demonstration of compliance**

1) **Design phase**

The systems integrator is to include the following information in the Cyber security design description:

- references to information provided by the suppliers (see Sec 5, [3.1.9]) that may be applied by the shipowner to establish plans to recover from cyber incidents.

2) **Construction phase**

No requirements.

3) **Commissioning phase**

The systems integrator is to submit Ship cyber resilience test procedure (ref. [5.3.2]) and demonstrate to the Society the effectiveness of the procedures and instructions provided by the suppliers to respond to cyber incidents as specified in [4.6.3] and [4.6.4].

The above tests may be omitted if performed during the certification of CBSs as per [5.3.2].

4) **Operation phase**

For general requirements to surveys in the operation phase, see [5.4].

The shipowner is in the Ship cyber security and resilience program to describe incident recovery plans. The plans are to cover the CBSs in scope of applicability of this Section and are to address at least the following requirements in this Section:

- Description of who, when and how to restore and recover from cyber incidents in accordance with requirements in [4.6.2]
- Policy for backup addressing frequency, maintenance and testing of the backups, considering acceptable downtime, availability of alternative means for control, vendor support arrangements and criticality of the CBSs in accordance with requirements in [4.6.3]
- Reference to user manuals or procedures for backup, shutdown, reset, restore and restart of the CBSs in accordance with requirements in [4.6.3] and [4.6.4].

First annual survey

The shipowner is to present to the Society records or other documented evidence demonstrating implementation of the Ship cyber security and resilience program, i.e., that:

- Instructions and/or procedures for incident recovery are available for the responsible personnel onboard
- Equipment, tools, documentation, and/or necessary software and data needed for recovery is available for the responsible personnel onboard
- Backup of the CBSs have been taken in accordance with the policies and procedures
- Manuals and procedures for shutdown, reset, restore and restart are available for the responsible personnel onboard.

Subsequent annual survey

The shipowner is upon request by the Society to demonstrate implementation of the Ship cyber security and resilience program by presenting records or other documented evidence as specified for the first annual survey.

4.6.3 Backup and restore capability (1/7/2024)

a) **Requirement**

CBSs and networks in the scope of applicability of this Section are to have the capability to support back-up and restore in a timely, complete and safe manner. Backups are to be regularly maintained and tested.

b) **Rationale**

In general, the purpose of a backup and restore strategy should protect against data loss and reconstruct the database after data loss. Typically, backup administration tasks include the following: Planning and testing responses to different kinds of failures; Configuring the database environment for backup and recovery; Setting up a backup schedule; Monitoring the backup and recovery environment; Creating a database copy for long-term storage; Moving data from one database or one host to another, etc.

c) **Requirement details**

1) **Restore capability**

CBSs in the scope of applicability of this Section are to have backup and restore capabilities to enable the

ship to safely regain navigational and operational state after a cyber incident.

Data are to be restorable from a secure copy or image.

Information and backup facilities are to be sufficient to recover from a cyber incident.

2) Backup

CBSs and networks in the scope of applicability of this Section are to provide backup for data. The use of offline backups is also to be considered to improve tolerance against ransomware and worms affecting online backup appliances.

Backup plans are to be developed, including scope, mode and frequency, storage medium and retention period.

d) Demonstration of compliance

1) Design phase

No requirements.

2) Construction phase

No requirements.

3) Commissioning phase

The systems integrator is to submit Ship cyber resilience test procedure (ref. [5.3.2]) and demonstrate to the Society the procedures and instructions for backup and restore provided by the suppliers for CBSs in the scope of applicability of this Section.

The above tests may be omitted if performed during the certification of CBSs as per [5.3.2].

4) Operation phase

For general requirements to surveys in the operation phase, see [5.4].

Special survey

Subject to modifications of the CBSs, the shipowner is to demonstrate to the Society the activities in [4.6.3] d), 3) as per the Ship cyber resilience test procedure.

4.6.4 Controlled shutdown, reset, roll-back and restart (1/7/2024)

a) Requirement

CBS and networks in the scope of applicability of this Section are to be capable of controlled shutdown, reset to an initial state, roll-back to a safe state and restart from a power-off condition in such state, in order to allow fast and safe recovery from a possible impairment due to a cyber incident.

Suitable documentation on how to execute the above-mentioned operations is to be available to onboard personnel.

b) Rationale

Controlled shutdown consists in turning a CBS or network off by software function allowing other connected systems to commit/rollback pending transactions, terminating processes, closing connections, etc. leaving the entire integrated system in a safe and known state. Controlled shutdown is opposed to hard shutdown, which occurs for example when the

computer is forcibly shut down by interruption of power.

While in the case of some cyber incidents hard shutdowns may be considered as a safety precaution, controlled shutdown is preferable in case of integrated systems to keep them in a consistent and known state with predictable behaviour. When standard shutdown procedures are not done, data or program and operating system files corruption may occur. In case of OT systems, the result of corruption can be instability, incorrect functioning or failure to provide the intended service.

The reset operation would typically kick off a soft boot, instructing the system to go through the process of shutting down, clear memory and reset devices to their initialized state. Depending on system considered, the reset operation might have different effects.

Rollback is an operation which returns the system to some previous state. Rollbacks are important for data and system integrity, because they mean that the system data and programs can be restored to a clean copy even after erroneous operations are performed. They are crucial for recovering from crashes and cyber incidents, restoring the system to a consistent state.

Restarting a system and reloading a fresh image of all the software and data (e.g. after a rollback operation) from a read-only source appears to be an effective approach to recover from unexpected faults or cyber incidents. Restart operations should be however controlled in particular for integrated systems, where unexpected restart of a single component can result in inconsistent system state or unpredictable behaviour.

c) Requirement details

CBS and networks in the scope of applicability of this Section are to be capable of:

- controlled shutdown allowing other connected systems to commit/rollback pending transactions, terminating processes, closing connections, etc. leaving the entire integrated system in a safe, consistent and known state
- resetting themselves, instructing the system to go through the process of shutting down, clear memory and reset devices to their initialized state
- rolling back to a previous configuration and/or state, to restore system integrity and consistency
- restarting and reloading a fresh image of all the software and data (e.g. after a rollback operation) from a read-only source. Restart time is to be compatible with the system's intended service and is not to bring other connected systems, or the integrated system it is part of, to an inconsistent or unsafe state.

Documentation is to be available to onboard personnel on how to execute the above-mentioned operations in case of a system affected by a cyber incident.

d) Demonstration of compliance

1) Design phase

The systems integrator is to include the following information in the Cyber security design description:

- references to product manuals or procedures describing how to safely shut down, reset, restore and restart the CBSs in the scope of applicability of this Section.
- 2) **Construction phase**
No requirements.
 - 3) **Commissioning phase**
The systems integrator is to submit Ship cyber resilience test procedure (ref. [5.3.2]) and demonstrate to the Society that manuals or procedures are established for shutdown, reset and restore of the CBSs in the scope of applicability of this Section. These manuals/procedures are to be provided to the shipowner. The above tests may be omitted if performed during the certification of CBSs as per [5.3.2].
 - 4) **Operation phase**
For general requirements to surveys in the operation phase, see [5.4].
Special survey
Subject to modifications of the CBSs, the shipowner is to demonstrate to the Society the activities in [4.6.4] d), 3) as per the Ship cyber resilience test procedure.

5 Demonstration of compliance

5.1 General

5.1.1 (1/7/2024)

Evaluation of compliance with requirements in this Section is to be carried out by the Society by assessment of documentation and survey in the relevant phases as specified in the following articles.

Documentation to be submitted by suppliers to the Society is specified in Sec 5. The approved versions of this documentation is also to be provided by the suppliers to the systems integrator as specified in Sec 5, [6.2].

Documents to be provided by the systems integrator are listed in [5.2] and [5.3].

Documents to be provided by the shipowner are listed in [5.4].

Upon delivery of the ship, the systems integrator is to provide below documentation to the shipowner:

- Documentation of the CBSs provided by the suppliers (see Sec 5, [6.2])
- Documentation produced by the systems integrator (see [5.1] and [5.2]).

See also [7] and [8] for a summary of the documents.

5.2 During design and construction phases

5.2.1 (1/7/2024)

The supplier is to demonstrate compliance to the Society by following the certification process specified in Sec 5, [6].

The systems integrator is to demonstrate compliance by submitting documents in the following articles to the Society for assessment.

During the design and construction phases, modifications to the design is to be carried out in accordance with the management of change (MoC) requirements in Sec 3.

5.2.2 Zones and conduit diagram (1/7/2024)

The content of this document is specified in [4.3.2] d), 1).

5.2.3 Cyber security design description (CSDD) (1/7/2024)

The content of this document is specified in articles "Design phase" for each requirement in [4].

5.2.4 Vessel asset inventory (1/7/2024)

The content of this document is specified in [4.2.2].

5.2.5 Risk assessment for the exclusion of CBSs (1/7/2024)

The content of this document is specified in [6].

5.2.6 Description of compensating countermeasures (1/7/2024)

If any CBS in the scope of applicability of this Section has been approved with compensating countermeasures in lieu of a requirement in Sec 5, this document is to specify the respective CBS, the lacking security capability, as well as provide a detailed description of the compensating countermeasures. See also Sec 5, [3.1.4] requiring that the supplier describes such compensating countermeasures in the system documentation.

5.3 Upon ship commissioning

5.3.1 (1/7/2024)

Before final commissioning of the ship, the systems integrator is to:

- a) Submit updated design documentation to the Society (as-built versions of the documents in [5.2])
- b) Submit Ship cyber resilience test procedure to the Society describing how to demonstrate compliance with this Section by testing and/or analytic evaluation
- c) Carry out testing, witnessed by the Society, in accordance with the approved Ship cyber resilience test procedure.

5.3.2 Ship cyber resilience test procedure (1/7/2024)

The content of this document is specified for the Commissioning phase in each article "Demonstration of compliance" in [4].

For each CBS, the required inherent security capabilities and configuration thereof are verified and tested in the certification process of each CBS (see Sec 5). Testing of such security functions may be omitted if specified in the respective article "Commissioning phase", on the condition that these security functions have been successfully tested during the certification of the CBS as per Sec 5. Nevertheless, all tests are to be included in the Ship cyber resilience test procedure and the decision to omit tests will be taken by the Society. Tests may generally not be omitted if findings/comments are carried over from the certification process to the commissioning phase, if the respective requirements have been met by compensating counter-

measures, or due to other reasons such as modifications of the CBS after the certification process.

The Ship cyber resilience test procedure is also to specify how to test any compensating countermeasures described in [5.2.3].

The Ship cyber resilience test procedure is to include means to update status and record findings during the testing, and specify the following information:

- Necessary test setup (i.e. to ensure the test can be repeated with the same expected result)
- Test equipment
- Initial condition(s)
- Test methodology, detailed test steps
- Expected results and acceptance criteria.

Before submitting the Ship cyber resilience test procedure to the Society, the systems integrator is to verify that the information is updated and placed under change management; that it is aligned with the latest configurations of CBSs and networks connecting such systems together onboard the ship and to other CBSs not onboard (e.g., ashore); and that the tests documented are sufficiently detailed as to allow verification of the installation and operation of measures adopted for the fulfilment of relevant requirements on the final configuration of CBSs and networks onboard.

The systems integrator is to document verification tests or assessments of security controls and measures in the fully integrated ship, maintaining change management for configurations, and noting in the documented test results where safety conditions may be affected by specific circumstances or failures addressed in the Ship cyber resilience test procedure.

The testing is to be carried out on board in accordance with the approved Ship cyber resilience test procedure after other commissioning activities for the CBSs are completed. The Society may request execution of additional tests.

5.4 During the operational life of the ship

5.4.1 (1/7/2024)

After the ship has been delivered to the shipowner, the shipowner is to manage technical and organisational security countermeasures by establishing and implementing processes as specified in this Section.

Modifications to the CBSs in scope of applicability of this Section are to be carried out in accordance with the management of change (MoC) requirements in Sec 3. This includes keeping documentation of the CBSs up to date.

The shipowner, with the support of suppliers, is to keep the Ship cyber resilience test procedure up to date and aligned with the CBSs onboard the ship and the networks connecting such systems to each other and to other CBSs not onboard (e.g. ashore). The shipowner is to update the Ship cyber resilience test procedure considering the

changes occurred on CBSs and networks onboard, possible emerging risks related to such changes, new threats, new vulnerabilities and other possible changes in the ship's operational environment.

The shipowner is to prepare and implement operational procedures, provide periodic training and carry out drills for the onboard personnel and other concerned personnel ashore to familiarize them with the CBSs onboard the ship and the networks connecting such systems to each other and to other CBSs not onboard (e.g. ashore), and to properly manage the measures adopted for the fulfilment of requirements.

The shipowner, with the support of supplier, is to keep the measures adopted for the fulfilment of requirements up to date, e.g. by periodic maintenance of hardware and software of CBSs onboard the ship and the networks connecting such systems.

The shipowner is to retain onboard a copy of results of execution of tests and an updated Ship cyber resilience test procedure and make them available to the Society.

5.4.2 First annual survey (1/7/2024)

In due time before the first annual survey of the ship, the shipowner is to submit to the Society a Ship cyber security and resilience program documenting management of cyber security and cyber resilience of the CBSs in the scope of applicability of this Section.

The Ship cyber security and resilience program is to include policies, procedures, plans and/or other information documenting the processes/activities specified in articles "Demonstration of compliance" in [4] of this Section.

After the Society has approved the Ship cyber security and resilience program, the shipowner is in the first annual survey to demonstrate compliance by presenting records or other documented evidence of implementation of the processes described in the approved Ship cyber security and resilience program.

Change of vessel management company will require a new verification of the Ship cyber security and resilience program.

5.4.3 Subsequent annual surveys (1/7/2024)

In the subsequent annual surveys of the ship, the shipowner is upon request by the Society to demonstrate implementation of the Ship cyber security and resilience program.

5.4.4 Special survey (1/7/2024)

Upon renewal of the ship's classification certificate, the shipowner is to carry out testing witnessed by the Society in accordance with the Ship cyber resilience test procedure. Certain security safeguards are to be demonstrated at Special survey whereas other need only be carried out upon request by the Society based on modifications to the CBSs as specified in articles "Operation phase" in [4].

6 Risk assessment for exclusion of CBS from the application of requirements

6.1 Requirement

6.1.1 (1/7/2024)

A risk assessment is to be carried out in case any of the CBSs falling under the scope of applicability of this Section is excluded from the application of relevant requirements. The risk assessment is to provide evidence of the acceptable risk level associated to the excluded CBSs.

6.2 Rationale

6.2.1 (1/7/2024)

Exclusion of a CBS falling under the scope of applicability of this Section from the application of relevant requirements needs to be duly justified and documented. Such exclusion can be accepted by the Society only if evidence is given that the risk level associated to the operation of the CBS is under an acceptable threshold by means of specific risk assessment.

The risk assessment is to be based on available knowledge bases and experience on similar designs, if any, considering the CBS category, connectivity and the functional requirements and specifications of the ship and of the CBS. Cyber threat information from internal and external sources may be used to gain a better understanding of the likelihood and impact of cybersecurity events.

6.3 Requirement details

6.3.1 (1/7/2024)

Risk assessment is to be made and kept up to date by the System integrator during the design and building phase considering possible variations of the original design and newly discovered threats and/or vulnerabilities not known from the beginning.

During the operational life of the ship, the shipowner is to update the risk assessment considering the constant changes in the cyber scenario and new weaknesses identified in CBS onboard in a process of continuous improvement. Should new risks be identified, the shipowner is to update existing, or implement new risk mitigation measures.

Should the changes in the cyber scenario be such as to elevate the risk level associated to the CBS under examination above the acceptable risk threshold, the shipowner is to inform the Society and submit the updated risk assessment for evaluation.

The envisaged operational environments for the CBS under examination are to be analyzed in the risk assessment to discern the likelihood of cyber incidents and the impact they could have on the human safety, the safety of the vessel or the marine environment, taking into account the category of the CBS. The attack surface is to be analyzed, taking into account the connectivity of the CBS, possible

interfaces for portable devices, logical access restrictions, etc.

Emerging risks related to the specific configuration of the CBS under examination are to be also identified. In the risk assessment, the following elements are to be considered:

- Asset vulnerabilities
- Threats, both internal and external
- Potential impacts of cyber incidents affecting the asset on human safety, safety of the vessel and/or threat to the environment
- Possible effects related to integration of systems, or interfaces among systems, including systems not onboard (e.g. if remote access to onboard systems is provided).

6.4 Acceptance criteria

6.4.1 (1/7/2024)

Exclusion of a CBS falling under the scope of applicability of this Section from the application of relevant requirements can be accepted by the Society only if assurance is given that the operation of the CBS has no impact on the safety of operations regarding cyber risk. The said exclusion may be accepted for a CBS which does not fully meet the additional criteria listed below but is provided with a rational explanation together with evidence and is found satisfactory by the Society. The Society may also require submittal of additional documents to consider the said exclusion.

The following criteria are to be met to exclude a system from the scope of applicability of this Section:

- a) The CBS is to be isolated (i.e. have no IP-network connections to other systems or networks)
- b) The CBS is to have no accessible physical interface ports. Unused interfaces are to be logically disabled. It is not to be possible to connect unauthorised devices to the CBS
- c) The CBS is to be located in areas to which physical access is controlled
- d) The CBS is not to be an integrated control system serving multiple ship functions as specified in the scope of applicability of this Section (see [1.4]).

The following additional criteria should be considered for the evaluation of risk level acceptability:

- a) The CBS should not serve ship functions of category III
- b) Known vulnerabilities, threats, potential impacts deriving from a cyber incident affecting the CBS have been duly considered in the risk assessment
- c) The attack surface for the CBS is minimized, having considered its complexity, connectivity, physical and logical access points, including wireless access points.

7 Summary of actions and documents

7.1 General

7.1.1 (1/7/2024)

Tab 2 provide a summary of actions and documents.

Table 2 (1/7/2024)

Document	Systems integrator			Shipowner			
	Design	Construction	Commissioning	Operation	1st AS (5)	AS (6)	SS (7)
Approved supplier documentation [5]		Maintain (3)	Maintain	Maintain			
Zones and conduit diagram [5.2.2]	Submit (2)	Maintain	Maintain	Maintain			
Cyber security design description [5.2.3]	Submit	Maintain	Maintain	Maintain			
Vessel asset inventory [5.2.4]	Submit	Maintain	Maintain	Maintain			
Risk assessment for the exclusion of CBSs [5.2.5] (1)	Submit	Maintain	Maintain	Maintain			
Description of compensating countermeasures [5.2.6] (1)	Submit	Maintain	Maintain	Maintain			
Ship cyber resilience test procedure [5.3.2]		Submit	Demonstrate (4)	Maintain			Demonstrate
Ship cyber security and resilience program [5.4.2] <ul style="list-style-type: none"> • Management of change (MoC) [4.2.2] d), 4) • Management of software updates [4.2.2] d), 4) • Management of firewalls [4.3.2] d), 4) • Management of malware protection [4.3.4] d), 4) • Management of access control [4.3.5] d), 4) • Management of confidential information [4.3.5] d), 4) • Management of remote access [4.3.7] d), 4) • Management of mobile and portable devices [4.3.8] d), 4) • Detection of security anomalies [4.4.2] d), 4) • Verification of security functions [4.4.3] d), 4) • Incident response plans [4.5.2] d), 4) • Recovery plans [4.6.2] d), 4) 				Maintain	Submit	Demonstrate	
Notes:							
(1) if applicable							
(2) The stakeholder is to submit the document to the Society for verification and approval of compliance with requirements in this Section							
(3) The stakeholder is to keep the document updated in accordance with procedure for management of change (MoC). Updated document and change management records are to be submitted to the Society as per Sec 3							
(4) The stakeholder is to demonstrate compliance to the Society in accordance with the approved document							
(5) First annual survey							
(6) Annual survey							
(7) Special survey							

8 Summary of requirements and documents

8.1 General

8.1.1 (1/7/2024)

Tab 3 to Tab 20 provides a summary of requirements and documents.

Table 3 (1/7/2024)

Vessel asset inventory (see [4.2.2])		
CBS security capabilities	Provide documentation of product security updates	Sec 5, [5.1.3]
	Provide documentation of dependent component security updates	Sec 5, [5.1.4]
CBS documentation	Provide security updates	Sec 5, [5.1.5]
	CBS asset inventory	Sec 5, [3.1.2]
	Management of change plan	Sec 5, [3.1.10]
Vessel design documentation	Vessel asset inventory	[4.2.2] d), 1)
Ship cyber security and resilience program	Management of change	[4.2.2] d), 4)
	Management of software updates	[4.2.2] d), 4)

Table 4 (1/7/2024)

Security zones and network segmentation (see [4.3.2])		
CBS security capabilities		
CBS documentation	Topology diagrams	Sec 5, [3.1.3]
Vessel design documentation	Zones and conduit diagram	[4.3.2] d), 1)
	Design description	[4.3.2] d), 1)
	Ship cyber resilience test procedure	[4.3.2] d), 3)
Ship cyber security and resilience program	Management of security zone boundary devices [e.g., firewalls]	[4.3.2] d), 4)

Table 5 (1/7/2024)

Network protection safeguards (see [4.3.3])		
CBS security capabilities	Denial of service (DoS) protection (item 24)	Sec 5, [4.2]
	Deterministic output (item 20)	
CBS documentation	Description of security capabilities	Sec 5, [3.1.4]
	Test procedure for security capabilities	Sec 5, [3.1.5]
Vessel design documentation	Ship cyber resilience test procedure	[4.3.3] d), 3)
Ship cyber security and resilience program		

Table 6 (1/7/2024)

Antivirus, antimalware, antispam and other protections from malicious code (see [4.3.4])		
CBS security capabilities	Malicious code protection (#18)	Sec 5, [4.2]
CBS documentation	Description of security capabilities	Sec 5, [3.1.4]
	Test procedure for security capabilities	Sec 5, [3.1.5]
Vessel design documentation	Design description	[4.3.4] d), 1)
	Ship cyber resilience test procedure	[4.3.4]d), 3)
Ship cyber security and resilience program	Management of malware protection	[4.3.4] d), 4)

Table 7 (1/7/2024)

Access control (see [4.3.5])		
CBS security capabilities	Human user id. and auth. (#1) Account management (#2) Identifier management (#3) Authenticator management (#4) Authorisation enforcement (#8)	Sec 5, [4.2]
CBS documentation	Description of security capabilities Test procedure for security capabilities	Sec 5, [3.1.4] Sec 5, [3.1.5]
Vessel design documentation	Design description Ship cyber resilience test procedure	[4.3.5] d), 1) [4.3.5] d), 3)
Ship cyber security and resilience program	Management of confidential information	[4.3.5] d), 4)
	Management of logical and physical access	[4.3.5] d), 4)

Table 8 (1/7/2024)

Wireless communication (see [4.3.6])		
CBS security capabilities	Wireless access management (#5) Wireless use control (#9)	Sec 5, [4.2]
CBS documentation	Description of security capabilities Test procedure for security capabilities	Sec 5, [3.1.4] Sec 5, [3.1.5]
Vessel design documentation	Design description Ship cyber resilience test procedure	[4.3.6] d), 1) [4.3.6] d), 3)
Ship cyber security and resilience program		

Table 9 (1/7/2024)

Remote access control and communication with untrusted networks (see [4.3.7])		
CBS security capabilities	Multifactor authentication (#31) Process / device id. and auth. (#32) Unsuccessful login attempts (#33) System use notification (#34) Access via untrusted networks (#35) Explicit access request approval (#36) Remote session termination (#37) Cryptographic integrity protection (#38) Input validation (#39) Session integrity (#40) Invalidation of session ID (#41)	Sec 5, [4.3]
CBS documentation	Description of security capabilities Test procedure for security capabilities	Sec 5, [3.1.4] Sec 5, [3.1.5]
Vessel design documentation	Design description Ship cyber resilience test procedure	[4.3.7] d), 1) [4.3.7] d), 3)
Ship cyber security and resilience program	Management of remote access and communication with/via untrusted networks	[4.3.7] d), 4)

Table 10 (1/7/2024)

Use of mobile and portable devices (see [4.3.8])		
CBS security capabilities	Use control for portable devices (#10)	Sec 5, [4.2]
CBS documentation	Description of security capabilities Test procedure for security capabilities	Sec 5, [3.1.4] Sec 5, [3.1.5]
Vessel design documentation	Design description Ship cyber resilience test procedure	[4.3.8] d), 1) [4.3.8] d), 3)
Ship cyber security and resilience program	Management of mobile and portable devices	[4.3.8] d), 4)

Table 11 (1/7/2024)

Network operation monitoring (see [4.4.2])		
CBS security capabilities	Use control for portable devices (#10) Auditable events (#13) Denial of service (DoS) protection (#24)	Sec 5, [4.2]
	Alarm excessive bandwidth use	Sec 3, [7.3.1]
CBS documentation	Description of security capabilities Test procedure for security capabilities	Sec 5, [3.1.4] Sec 5, [3.1.5]
Vessel design documentation	Ship cyber resilience test procedure	[4.4.2] d), 3)
Ship cyber security and resilience program	Incident response plans	[4.4.2] d), 4)

Table 12 (1/7/2024)

Verification and diagnostic functions of CBS and networks (see [4.4.3])		
CBS security capabilities	Security function verification (#19)	Sec 5, [4.2]
CBS documentation	Description of security capabilities Test procedure for security capabilities Plans for maintenance and verification	Sec 5, [3.1.4] Sec 5, [3.1.5] Sec 5, [3.1.8]
Vessel design documentation	Ship cyber resilience test procedure	[4.4.3] d), 3)
Ship cyber security and resilience program	Verification of security functions	[4.4.3] d), 4)

Table 13 (1/7/2024)

Incident response plan (see [4.5.2])		
CBS security capabilities		
CBS documentation	Description of security capabilities Test procedure for security capabilities Information supporting incident response and recovery plans	Sec 5, [3.1.4] Sec 5, [3.1.5] Sec 5, [3.1.9]
Vessel design documentation	Design description Ship cyber resilience test procedure	[4.5.2] d), 1) [4.5.2] d), 3)
Ship cyber security and resilience program	Incident response plans	[4.5.2] d), 4)

Table 14 (1/7/2024)

Local, independent and/or manual operation (see [4.5.3])		
CBS security capabilities		
CBS documentation	Description of security capabilities Test procedure for security capabilities Information supporting incident response and recovery plans	Sec 5, [3.1.4] Sec 5, [3.1.5] Sec 5, [3.1.9]
Vessel design documentation	Design description Ship cyber resilience test procedure	[4.5.3] d), 1) [4.5.3] d), 3)
Ship cyber security and resilience program	Incident response plans	[4.5.2] d), 4)

Table 15 (1/7/2024)

Network isolation (see [4.5.4])		
CBS security capabilities		
CBS documentation	Description of security capabilities Test procedure for security capabilities Information supporting incident response and recovery plans	Sec 5, [3.1.4] Sec 5, [3.1.5] Sec 5, [3.1.9]
Vessel design documentation	Design description Ship cyber resilience test procedure	[4.5.4] d), 1) [4.5.4] d), 3)
Ship cyber security and resilience program	Incident response plans	[4.5.2] d), 4)

Table 16 (1/7/2024)

Fallback to a minimal risk condition (see [4.5.5])		
CBS security capabilities	Deterministic output (#20)	Sec 5, [4.2]
CBS documentation	Description of security capabilities Test procedure for security capabilities Information supporting incident response and recovery plans	Sec 5, [3.1.4] Sec 5, [3.1.5] Sec 5, [3.1.9]
Vessel design documentation	Design description Ship cyber resilience test procedure	[4.5.5] d), 1) [4.5.5] d), 3)
Ship cyber security and resilience program	Incident response plans	[4.5.2] d), 4)

Table 17 (1/7/2024)

Recovery plan (see [4.6.2])		
CBS security capabilities		
CBS documentation	Description of security capabilities Test procedure for security capabilities Information supporting incident response and recovery plans	Sec 5, [3.1.4] Sec 5, [3.1.5] Sec 5, [3.1.9]
Vessel design documentation	Design description Ship cyber resilience test procedure	[4.6.2] d), 1) [4.6.2] d), 3)
Ship cyber security and resilience program	Recovery plans	[4.6.2] d), 4)

Table 18 (1/7/2024)

Backup and restore capability (see [4.6.3])		
CBS security capabilities	System backup (#26) System recovery and reconstitution (#27)	Sec 5, [4.2]
CBS documentation	Description of security capabilities Test procedure for security capabilities Information supporting incident response and recovery plans	Sec 5, [3.1.4] Sec 5, [3.1.5] Sec 5, [3.1.9]
Vessel design documentation	Ship cyber resilience test procedure	[4.6.3] d), 3)
Ship cyber security and resilience program	Recovery plan	[4.6.2] d), 4)

Table 19 (1/7/2024)

Controlled shutdown, reset, restore and restart (see [4.6.4])		
CBS security capabilities	System recovery and reconstitution (#27)	Sec 5, [4.2]
CBS documentation	Description of security capabilities Test procedure for security capabilities Information supporting incident response and recovery plans	Sec 5, [3.1.4] Sec 5, [3.1.5] Sec 5, [3.1.9]
Vessel design documentation	Design description Ship cyber resilience test procedure	[4.6.4] d), 1) [4.6.4] d), 3)
Ship cyber security and resilience program	Recovery plans	[4.6.2] d), 4)

Table 20 (1/7/2024)

Risk assessment for exclusion of CBS from the application of requirements (see [6])		
CBS security capabilities		
CBS documentation		
Vessel design documentation	Risk assessment for the exclusion of CBSs	[5.2.5]
Ship cyber security and resilience program		

SECTION 5

CYBER RESILIENCE OF ON-BOARD SYSTEMS AND EQUIPMENT

1 General

1.1 Introduction

1.1.1 (1/7/2024)

This Section specifies requirements for cyber resilience of on-board systems and equipment.

1.2 Limitations

1.2.1 (1/7/2024)

This Section does not cover environmental performance for the system hardware and the functionality of the software.

1.3 Scope of applicability

1.3.1 (1/7/2024)

The requirements specified in this Section are applicable to computer based systems specified in Sec 4 for the following types of vessels:

- **Mandatory requirements for:**
 - Passenger ships (including passenger high-speed craft) engaged in international voyages
 - Cargo ships of 500 GT and upwards engaged in international voyages
 - High speed craft of 500 GT and upwards engaged in international voyage
 - Mobile offshore drilling units of 500 GT and upwards
 - Self-propelled mobile offshore units engaged in construction (i.e. wind turbine installation maintenance and repair, crane units, drilling tenders, accommodation, etc).
- **Non-mandatory guidance to:**
 - Ships of war and troopships
 - Cargo ships less than 500 gross tonnage
 - Vessels not propelled by mechanical means
 - Wooden ships of primitive build
 - Passenger yachts (passengers not more than 12)
 - Pleasure yachts not engaged in trade
 - Fishing vessels
 - Site specific offshore installations (i.e. FPSOs, FSUs, etc).

For navigation and radiocommunication systems, the application of IEC 61162-460 or other equivalent standards in lieu of the required security capabilities in [4] may be accepted by the Society, on the condition that requirements in Sec 4 are complied with.

1.3.2 Information and Communication Technology (ICT) (1/7/2024)

Attention is made to the following requirements on Computer Based Systems and Cyber Resilience:

- Sec 3 “Computer based systems” which includes requirements for design, construction, commissioning and maintenance of computer-based systems where they depend on software for the proper achievement of their functions. The requirements in Sec 3 focus on the functionality of the software and on the hardware supporting the software which provide control, alarm, monitoring, safety or internal communication functions
- Sec 4 “Cyber resilience of Ships” which includes requirements for cyber resilience of ships, with the purpose of providing technical means to stakeholders which would lead to cyber resilient ships
- IACS Recommendation 166 on Cyber Resilience: non-mandatory recommended technical requirements that stakeholders may reference and apply to assist with the delivery of cyber resilient ships, whose resilience can be maintained throughout their service life.

1.4 Definitions & Abbreviations

1.4.1 (1/7/2024)

Attack surface: the set of all possible points where an unauthorized user can access a system, cause an effect on or extract data from. The attack surface comprises two categories: digital and physical. The digital attack surface encompasses all the hardware and software that connect to an organization’s network. These include applications, code, ports, servers and websites. The physical attack surface comprises all endpoint devices that an attacker can gain physical access to, such as desktop computers, hard drives, laptops, mobile phones, removable drives and carelessly discarded hardware.

Authentication: provision of assurance that a claimed characteristic of an identity is correct.

Compensating countermeasure: an alternate solution to a countermeasure employed in lieu of or in addition to inherent security capabilities to satisfy one or more security requirements.

Computer Based System (CBS): A programmable electronic device, or interoperable set of programmable electronic devices, organized to achieve one or more specified purposes such as collection, processing, maintenance, use, sharing, dissemination, or disposition of information. CBS on-board include IT and OT systems. A CBS may be a combination of subsystems connected via network. On-board CBS may be connected directly or via public means of communications (e.g. Internet) to ashore CBSs, other vessels’ CBS and/or other facilities.

Computer Network : a connection between two or more computers for the purpose of communicating data electronically by means of agreed communication protocols.

Control: means of managing risk, including policies, procedures, guidelines, practices or organizational structures, which can be administrative, technical, management, or legal in nature.

Cyber incident: an event resulting from any offensive cyber manoeuvre, either intentional or unintentional, that targets or affects one or more CBS onboard, which actually or potentially results in adverse consequences to an onboard system, network and computer or the information that they process, store or transmit, and which may require a response action to mitigate the consequences. Cyber incidents include unauthorized access, misuse, modification, destruction or improper disclosure of the information generated, archived or used in onboard CBS or transported in the networks connecting such systems. Cyber incidents do not include system failures.

Cyber resilience: the capability to reduce the occurrence and mitigating the effects of incidents arising from the disruption or impairment of operational technology (OT) used for the safe operation of a ship, which potentially lead to dangerous situations for human safety, safety of the vessel and/or threat to the environment.

Defence in depth: information Security strategy integrating people, technology, and operations capabilities to establish variable barriers across multiple layers and missions of the organization.

Essential Systems: Computer Based System contributing to the provision of services essential for propulsion and steering, and safety of the ship. Essential services comprise "Primary Essential Services" and "Secondary Essential Services": Primary Essential Services are those services which need to be in continuous operation to maintain propulsion and steering; Secondary Essential Services are those services which need not necessarily be in continuous operation to maintain propulsion and steering but which are necessary for maintaining the vessel's safety.

Firewall: a logical or physical barrier that monitors and controls incoming and outgoing network traffic controlled via predefined rules.

Firmware: software embedded in electronic devices that provide control, monitoring and data manipulation of engineered products and systems. These are normally self-contained and not accessible to user manipulation.

Hardening: hardening is the practice of reducing a system's vulnerability by reducing its attack surface.

Information Technology (IT): devices, software and associated networking focusing on the use of data as information, as opposed to Operational Technology (OT).

Integrated system: a system combining a number of interacting sub-systems and/or equipment organized to achieve one or more specified purposes.

Network switch (Switch): a device that connects devices together on a computer network, by using packet switching to receive, process and forward data to the destination device.

Offensive cyber manoeuvre: actions that result in denial, degradation, disruption, destruction, or manipulation of OT or IT systems.

Operational technology (OT): devices, sensors, software and associated networking that monitor and control onboard systems. Operational technology systems may be thought of as focusing on the use of data to control or monitor physical processes.

OT system: computer based systems, which provide control, alarm, monitoring, safety or internal communication functions.

Patches: software designed to update installed software or supporting data to address security vulnerabilities and other bugs or improve operating systems or applications.

Protocols: a common set of rules and signals that computers on the network use to communicate. Protocols allow to perform data communication, network management and security. Onboard networks usually implement protocols based on TCP/IP stacks or various field buses.

Recovery: develop and implement the appropriate activities to maintain plans for resilience and to restore any capabilities or services that were impaired due to a cyber security event. The Recovery function supports timely return to normal operations to reduce the impact from a cyber security event.

Supplier: a manufacturer or provider of hardware and/or software products, system components or equipment (hardware or software) comprising of the application, embedded devices, network devices, host devices etc. working together as system or a subsystem. The Supplier is responsible for providing programmable devices, sub-systems or systems to the System Integrator.

System: combination of interacting programmable devices and/or sub-systems organized to achieve one or more specified purposes.

System Categories (I, II, III): system categories based on their effects on system functionality, which are defined in Sec 3.

System Integrator: the specific person or organization responsible for the integration of systems and products provided by suppliers into the system invoked by the requirements in the ship specifications and for providing the integrated system. The system integrator may also be responsible for integration of systems in the ship. Until vessel delivery, this role is to be taken by the Shipyard unless an alternative organization is specifically contracted/assigned this responsibility.

Untrusted network: any network outside the scope of applicability of this Section.

1.5 Requirements and Credits

1.5.1 (1/7/2024)

The requirements in this Section are to be applied in conjunction with the applicable ones in Sec 3, Sec 4 and Sec 8.

The following credits may also be considered:

- IACS Rec 166 (Corr.1 2020): Recommendation on Cyber Resilience

- IEC 62443-3-3 (2013): Industrial communication networks – Network and system security. Part 3-3: System security requirements and security levels
- IEC 62443-4-1 (2018): Security for industrial automation and control systems Part 4-1: Secure product development lifecycle requirements.

2 Security Philosophy

2.1 Systems and Equipment

2.1.1 (1/7/2024)

A System can consist of group of hardware and software enabling safe, secure and reliable operation of a process. Typical example could be Engine control system, DP system, etc.

2.1.2 (1/7/2024)

Equipment may be one of the following:

- Network devices (i.e. routers, managed switches)
- Security devices (i.e. firewall, Intrusion Detection System)
- Computers (i.e. workstation, servers)
- Automation devices (i.e. Programmable Logic Controllers)
- Virtual machine cloud-hosted.

2.2 Cyber Resilience

2.2.1 (1/7/2024)

The cyber resilience requirements in [4] will be applicable for all systems in scope of Sec 4 as applicable. Additional requirements related to interface with untrusted networks will only apply for systems where such connectivity is designed.

2.3 Essential Systems Availability

2.3.1 (1/7/2024)

Security measures for Essential system are not to adversely affect the systems availability.

2.3.2 (1/7/2024)

Implementation of security measures is not to cause loss of safety functions, loss of control functions, loss of monitoring functions or loss of other functions which could result in health, safety and environmental consequences.

2.3.3 (1/7/2024)

The system is to be adequately designed to allow the ship to continue its mission critical operations in a manner that ensures the confidentiality, integrity, and availability of the data necessary for safety of the vessel, its systems, personnel and cargo.

2.4 Compensating Countermeasures

2.4.1 (1/7/2024)

Compensating countermeasure may be employed in lieu of or in addition to inherent security capabilities to satisfy one or more security requirements.

Compensating countermeasure(s) is(are) to meet the intent and rigor of the original stated requirement considering the referenced standards as well as the differences between each requirement and the related items in the standards, and follow the principles specified in [3.1.4].

3 Documentation

3.1 CBS Documentation

3.1.1 (1/7/2024)

The following documents are to be submitted to the Society for review and approval in accordance with the requirements in this Section; see also [6.2].

3.1.2 CBS asset inventory (1/7/2024)

The CBS asset inventory is to include the information below:

- List of hardware components (e.g., host devices, embedded devices, network devices) Name
- Brand/manufacturer
- Model/type
- Short description of functionality/purpose
- Physical interfaces (e.g., network, serial)
- Name/type of system software (e.g., operating system, firmware)
- Version and patch level of system software
- Supported communication protocols

List of software components (e.g., application software, utility software)

- The hardware component where it is installed
- Brand/manufacturer
- Model/type
- Short description of functionality/purpose
- Version of software

3.1.3 Topology diagrams (1/7/2024)

The physical topology diagram is to illustrate the physical architecture of the system. It is to be possible to identify the hardware components in the CBS asset inventory. The diagram is to illustrate the following:

- All endpoints and network devices, including identification of redundant units
- Communication cables (networks, serial links), including communication with I/O units
- Communication cables to other networks or systems

The logical topology diagram is to illustrate the data flow between components in the system. The diagram is to illustrate the following:

- Communication endpoints (e.g. workstations, controllers, servers)
- Network devices (switches, routers, firewalls)
- Physical and virtual computers
- Physical and virtual communication paths

- Communication protocols

One combined topology diagram may be acceptable if all requested information can be clearly illustrated.

3.1.4 Description of security capabilities (1/7/2024)

This document is to describe how the CBS with its hardware and software components meets the required security capabilities in [4.2].

Any network interfaces to other CBSs in the scope of applicability of Sec 4 is to be described. The description is to include destination CBS, data flows, and communication protocols. If the System integrator has allocated the destination CBS to another security zone, components providing protection of the security zone boundary (see Sec 4, [4.3.3] a) are to be described in detail if delivered as part of the CBS.

Any network interfaces to other systems or networks outside the scope of applicability of Sec 4 (untrusted networks) are to be described. The description is to specify compliance with the additional security capabilities in [4.3], and include relevant procedures or instructions for the crew. Components providing protection of the security zone boundary (see Sec 4, [4.3.3] a) are to be described in detail if delivered as part of the CBS.

A separate chapter is to be designated for each requirement. All hardware and software components in the system are to be addressed in the description, as relevant.

If any requirement is not fully met, this is to be specified in the description, and compensating countermeasures are to be proposed. The compensating countermeasures should:

- Protect against the same threats as the original requirement
- Provide an equal level of protection as the original requirement
- Not be a security control that is required by other requirements in this Section
- Not introduce higher security risk.

Any supporting documents (e.g. OEM information) necessary to verify compliance with the requirements are to be referenced in the description and submitted.

3.1.5 Test procedure of security capabilities (1/7/2024)

This document is to describe how to demonstrate by testing that the system complies with the requirements in [4.2] and [4.3], including any compensating countermeasures. Demonstration of compliance by analytic evaluation may be specially considered. The procedure is to include a separate chapter for each applicable requirement and describe:

- Necessary test setup (i.e. to ensure the test can be repeated with the same expected result)
- Test equipment
- Initial condition(s)
- Test methodology, detailed test steps
- Expected results and acceptance criteria

The procedure is to also include means to update test results and record findings during the testing.

3.1.6 Security configuration guidelines (1/7/2024)

This document is to describe recommended configuration settings of the security capabilities and specify default values. The objective is to ensure the security capabilities are implemented in accordance with Sec 4 and any specifications by the System integrator (e.g. user accounts, authorisation, password policies, safe state of machinery, firewall rules, etc.)

The document is to serve as basis for verification of item no. 29 in Tab 1.

3.1.7 Secure development lifecycle documents (1/7/2024)

This documentation is to be submitted to the Society upon request and is to describe the supplier's processes and controls in accordance with requirements for secure development lifecycle in [5]. Software updates and patching are to be described. The document is to prepare the Society for survey as per [6.3.5].

3.1.8 Plans for maintenance and verification of the CBS (1/7/2024)

This documentation is to be submitted to the Society upon request and is to include procedures for security-related maintenance and testing of the system. The document is to include instructions for how the user can verify correct operation of the system's security functions as required by item no.19 in Tab 1.

3.1.9 Information supporting the owner's incident response and recovery plan (1/7/2024)

This documentation is to be submitted to the Society upon request and is to include procedures or instructions allowing the user to accomplish the following:

- Local independent control (see Sec 4, [4.5.3])
- Network isolation (see Sec 4, [4.5.4])
- Forensics by use of audit records (see Tab 1, item no.13)
- Deterministic output (see Sec 4, [4.5.5] and Tab 1, item no. 20)
- Backup (see Tab 1, item no. 26)
- Restore (see Tab 1, item no. 27)
- Controlled shutdown, reset, roll-back and restart (see Sec 4, [4.6.4]).

3.1.10 Management of change plan (1/7/2024)

This documentation is to be submitted to the Society upon request. It is expected that this procedure is not specific for cyber security and is also required by Sec 3.

3.1.11 Test reports (1/7/2024)

CBSs with Type approval certificate covering the security capabilities of this Section may be exempted from survey by the Society. However, test reports signed by the supplier are to be submitted to the Society, demonstrating that the supplier has completed design, construction, testing, configuration, and hardening as would otherwise be verified by the Society in survey (see [6.3]).

4 System Requirements

4.1 General

4.1.1 (1/7/2024)

This Article specifies the required security capabilities for CBSs in the scope specified in [1.3].

The requirements in this Article are based on the selected requirements in IEC 62443-3-3. To determine the full

content, rationale and relevant guidance for each requirement, the reader should consult the referenced standard.

4.2 Required security capabilities

4.2.1 (1/7/2024)

The following security capabilities are required for all CBSs in the scope specified in [1.3].

Table 1 (1/7/2024)

Item No	Objective	Requirements
Protect against casual or coincidental access by unauthenticated entities		
1	Human user identification and authentication	The CBS is to identify and authenticate all human users who can access the system directly or through interfaces (IEC 62443-3-3/SR 1.1)
2	Account management	The CBS is to provide the capability to support the management of all accounts by authorized users, including adding, activating, modifying, disabling and removing account (IEC 62443-3-3/SR 1.3)
3	Identifier management	The CBS is to provide the capability to support the management of identifiers by user, group and role. (IEC 62443-3-3/SR 1.4)
4	Authenticator management	The CBS is to provide the capability to: - Initialize authenticator content - Change all default authenticators upon control system installation - Change/refresh all authenticators - Protect all authenticators from unauthorized disclosure and modification when stored and transmitted. (IEC 62443-3-3/SR 1.5)
5	Wireless access management	The CBS is to provide the capability to identify and authenticate all users (humans, software processes or devices) engaged in wireless communication (IEC 62443-3-3/SR 1.6)
6	Strength of password-based authentication	The CBS is to provide the capability to enforce configurable password strength based on minimum length and variety of character types. (IEC 62443-3-3/SR 1.7)
7	Authenticator feedback	The CBS is to obscure feedback during the authentication process. (IEC 62443-3-3/SR 1.10)
Protect against casual or coincidental misuse		
8	Authorization enforcement	On all interfaces, human users are to be assigned authorizations in accordance with the principles of segregation of duties and least privilege. (IEC 62443-3-3/SR 2.1)
9	Wireless use control	The CBS is to provide the capability to authorize, monitor and enforce usage restrictions for wireless connectivity to the system according to commonly accepted security industry practices (IEC 62443-3-3/SR 2.2)
10	Use control for portable and mobile devices	When the CBS supports use of portable and mobile devices, the system is to include the capability to: (1) a) Limit the use of portable and mobile devices only to those permitted by design b) Restrict code and data transfer to/from portable and mobile devices (IEC 62443-3-3/SR 2.3)
11	Mobile code	The CBS is to control the use of mobile code such as java scripts, ActiveX and PDF. (IEC 62443-3-3/SR 2.4)
12	Session lock	The CBS is to be able to prevent further access after a configurable time of inactivity or following activation of manual session lock. (IEC 62443-3-3/SR 2.5)

Item No	Objective	Requirements
13	Auditable events	The CBS is to generate audit records relevant to security for at least the following events: access control, operating system events, backup and restore events, configuration changes, loss of communication. (IEC 62443-3-3/SR 2.8)
14	Audit storage capacity	The CBS is to provide the capability to allocate audit record storage capacity according to commonly recognized recommendations for log management. Auditing mechanisms are to be implemented to reduce the likelihood of such capacity being exceeded. (IEC 62443-3-3/SR 2.9)
15	Response to audit processing failures	The CBS is to provide the capability to prevent loss of essential services and functions in the event of an audit processing failure. (IEC 62443-3-3/SR 2.10)
16	Timestamps	The CBS is to timestamp audit records. (IEC 62443-3-3/SR 2.11)
Protect the integrity of the CBS against casual or coincidental manipulation		
17	Communication integrity	The CBS is to protect the integrity of transmitted information. (2) (IEC 62443-3-3/SR 3.1)
18	Malicious code protection	The CBS is to provide capability to implement suitable protection measures to prevent, detect and mitigate the effects due to malicious code or unauthorized software. It is to have the feature for updating the protection mechanisms (IEC 62443-3-3/SR 3.2)
19	Security functionality verification	The CBS is to provide the capability to support verification of the intended operation of security functions and report when anomalies occur during maintenance (IEC 62443-3-3/SR 3.3)
20	Deterministic output	The CBS is to provide the capability to set outputs to a predetermined state if normal operation cannot be maintained as a result of an attack. The predetermined state could be: - Unpowered state, - Last-known value, or - Fixed value (IEC 62443-3-3/SR 3.6)
Prevent the unauthorized disclosure of information via eavesdropping or casual exposure		
21	Information confidentiality	The CBS is to provide the capability to protect the confidentiality of information for which explicit read authorization is supported, whether at rest or in transit. (3) (IEC 62443-3-3/SR 4.1)
22	Use of cryptography	If cryptography is used, the CBS is to use cryptographic algorithms, key sizes and mechanisms according to commonly accepted security industry practices and recommendations. (IEC 62443-3-3/SR 4.3)
Monitor the operation of the CBS and respond to incidents		
23	Audit log accessibility	The CBS is to provide the capability for accessing audit logs on read only basis by authorized humans and/or tools. (IEC 62443-3-3/SR 6.1)
Ensure that the control system operates reliably under normal production conditions		
24	Denial of service protection	The CBS is to provide the minimum capability to maintain essential functions during DoS events. (4) (IEC 62443-3-3/SR 7.1)
25	Resource management	The CBS is to provide the capability to limit the use of resources by security functions to prevent resource exhaustion. (IEC 62443-3-3/SR 7.2)

Item No	Objective	Requirements
26	System backup	The identity and location of critical files and the ability to conduct backups of user-level and system-level information (including system state information) is to be supported by the CBS without affecting normal operations (IEC 62443-3-3/SR 7.3)
27	System recovery and reconstitution	The CBS is to provide the capability to be recovered and reconstituted to a known secure state after a disruption or failure. (IEC 62443-3-3/SR 7.4)
28	Alternative power source	The CBS is to provide the capability to switch to and from an alternative power source without affecting the existing security state or a documented degraded mode. (IEC 62443-3-3/SR 7.5)
29	Network and security configuration settings	The CBS traffic is to provide the capability to be configured according to recommended network and security configurations as described in guidelines provided by the supplier. The CBS is to provide an interface to the currently deployed network and security configuration settings. (IEC 62443-3-3/SR 7.6)
30	Least Functionality	The installation, the availability and the access rights of the following are to be limited to the strict needs of the functions provided by the CBS: - operating systems software components, processes and services - network services, ports, protocols, routes and hosts accesses and any software (IEC 62443-3-3/SR 7.7)
Notes: (1) Port limits / blockers (and silicone) could be accepted for a specific system (2) Cryptographic mechanisms are to be employed for wireless networks (3) For wireless network, cryptographic mechanisms are to be employed to protect confidentiality of all information in transit (4) It is acceptable that the CBS may operate in a degraded mode upon DoS events, but it is not to fail in a manner which may cause hazardous situations. Overload-based DoS events should be considered, i.e. where the networks capacity is attempted flooded, and where the resources of a computer is attempted consumed.		

4.3 Additional security capabilities

works (i.e. interface to any networks outside the scope of Sec 4).

4.3.1 (1/7/2024)

The following additional security capabilities are required for CBSs with network communication to untrusted net-

CBSs with communication traversing the boundaries of security zones are to also meet requirements for network segmentation and zone boundary protection in Sec 4, [4.3.2] and Sec 4, [4.3.3].

Table 2 (1/7/2024)

Item No	Objective	Requirements
31	Multifactor authentication for human users	Multifactor authentication is required for human users when accessing the CBS from or via an untrusted network. (IEC 62443-3-3/SR 1.1, RE 2)
32	Software process and device identification and authentication	The CBS is to identify and authenticate software processes and devices (IEC 62443-3-3/SR 1.2)
33	Unsuccessful login attempts	The CBS is to enforce a limit of consecutive invalid login attempts from untrusted networks during a specified time period. (IEC 62443-3-3/SR 1.11)
34	System use notification	The CBS is to provide the capability to display a system use notification message before authenticating. The system use notification message is to be configurable by authorized personnel. (IEC 62443-3-3/SR 1.12)

Item No	Objective	Requirements
35	Access via Untrusted Networks	Any access to the CBS from or via untrusted networks is to be monitored and controlled. (IEC 62443-3-3/SR 1.13)
36	Explicit access request approval	The CBS is to deny access from or via untrusted networks unless explicitly approved by authorized personnel on board. (IEC 62443-3-3/SR 1.13, RE1)
37	Remote session termination	The CBS is to provide the capability to terminate a remote session either automatically after a configurable time period of inactivity or manually by the user who initiated the session. (IEC 62443-3-3/SR 2.6)
38	Cryptographic integrity protection	The CBS is to employ cryptographic mechanisms to recognize changes to information during communication with or via untrusted networks. (IEC 62443-3-3/SR 3.1, RE1)
39	Input validation	The CBS is to validate the syntax, length and content of any input data via untrusted networks that is used as process control input or input that directly impacts the action of the CBS. (IEC 62443-3-3/SR 3.5)
40	Session integrity	The CBS is to protect the integrity of sessions. Invalid session IDs are to be rejected. (IEC 62443-3-3/SR 3.8)
41	Invalidation of session IDs after session termination	The system is to invalidate session IDs upon user logout or other session termination (including browser sessions). (IEC 62443-3-3/SR 3.8, RE1)

5 Secure Development Lifecycle Requirements

5.1 General

5.1.1 (1/7/2024)

A Secure Development Lifecycle (SDLC) broadly addressing security aspects in following stages is to be followed for the development of systems or equipment

- Requirement analysis phase
- Design phase
- Implementation phase
- Verification phase
- Release phase
- Maintenance Phase
- End of life phase

A document, is to be produced that records how the security aspects have been addressed in above phases and is to at minimum integrate controlled processes as set out in below [5.1.2] to [5.1.8]. The said document is required to be submitted to the Society for review and approval.

5.1.2 IEC 62443-4-1/SM-8 (1/7/2024)

The manufacturer is to have procedural and technical controls in place to protect private keys used for code signing, if applicable, from unauthorized access or modification.

5.1.3 IEC 62443-4-1/SUM-2 (1/7/2024)

A process is to be employed to ensure that documentation about product security updates is made available to users

(which could be through establishing a cyber security point of contact or periodic publication which can be accessed by the user) that includes but is not limited to:

- a) The product version number(s) to which the security patch applies
- b) Instructions on how to apply approved patches manually and via an automated process
- c) Description of any impacts that applying the patch to the product can have, including reboot
- d) Instructions on how to verify that an approved patch has been applied
- e) Risks of not applying the patch and mediations that can be used for patches that are not approved or deployed by the asset owner.

5.1.4 IEC 62443-4-1/SUM-3 (1/7/2024)

A process is to be employed to ensure that documentation about dependent component or operating system security updates is available to users that includes but is not limited to:

- a) Stating whether the product is compatible with the dependent component or operating system security update

5.1.5 IEC 62443-4-1/SUM-4 (1/7/2024)

A process is to be employed to ensure that security updates for all supported products and product versions are made available to product users in a manner that facilitates verification that the security patch is authentic.

IACS supplement: The manufacturer is to have QA process to test the updates before releasing.

5.1.6 IEC 62443-4-1/SG-1 (1/7/2024)

A process is to exist to create product documentation that describes the security defence in depth strategy for the product to support installation, operation and maintenance that includes:

- a) Security capabilities implemented by the product and their role in the defence in depth strategy
- b) Threats addressed by the defence in depth strategy
- c) Product user mitigation strategies for known security risks associated with the product, including risks associated with legacy code.

5.1.7 IEC 62443-4-1/SG-2 (1/7/2024)

A process is to be employed to create product user documentation that describes the security defence in depth measures expected to be provided by the external environment in which the product is to be used.

5.1.8 IEC 62443-4-1/SG-3 (1/7/2024)

A process is to be employed to create product user documentation that includes guidelines for hardening the product when installing and maintaining the product. The guidelines are to include, but are not limited to, instructions, rationale and recommendations for the following:

- a) Integration of the product, including third-party components, with its product security context
- b) Integration of the product's application programming interfaces/protocols with user applications
- c) Applying and maintaining the product's defence in depth strategy
- d) Configuration and use of security options/capabilities in support of local security policies, and for each security option/capability:
 - 1) its contribution to the product's defence in depth strategy

- 2) descriptions of configurable and default values that include how each affects security along with any potential impact each has on work practices
- 3) setting/changing/deleting its value.
- e) Instructions and recommendations for the use of all security-related tools and utilities that support administration, monitoring, incident handling and evaluation of the security of the product
- f) Instructions and recommendations for periodic security maintenance activities
- g) Instructions for reporting security incidents for the product to the supplier
- h) Description of the security best practices for maintenance and administration of the product.

6 Demonstration of compliance

6.1 General

6.1.1 (1/7/2024)

Suppliers are to in cooperation with the System integrator determine if this Section is mandatory for the CBS, see Fig 1.

Compliance with security requirements is to be demonstrated as indicated in Fig 2. This classification process is ship-specific and is to result in a System certificate.

Type approval is voluntary and applies for CBSs that are standard and routinely manufactured. See Sec 3 for definition of System certification and Type approval.

The process in Fig 1 and Fig 2 applies also if other equivalent standards are applied for navigation and radiocommunication equipment (see [1.3]). In such case:

- the process in Fig 1 illustrates if the equivalent standard is mandatory (in lieu of this Section)
- the process in Fig 2 illustrates that the certification process is lessened if the CBS has been type approved in accordance with the equivalent standard.

Figure 1 (1/7/2024)

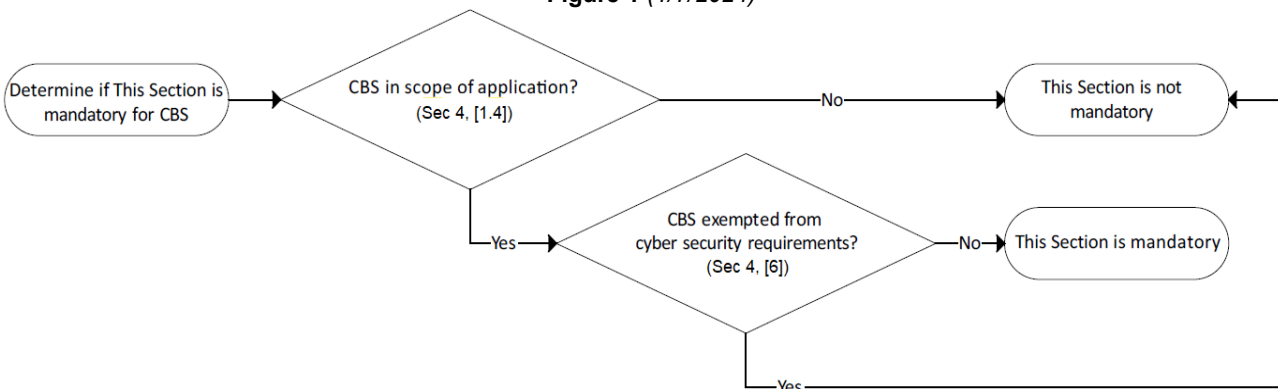
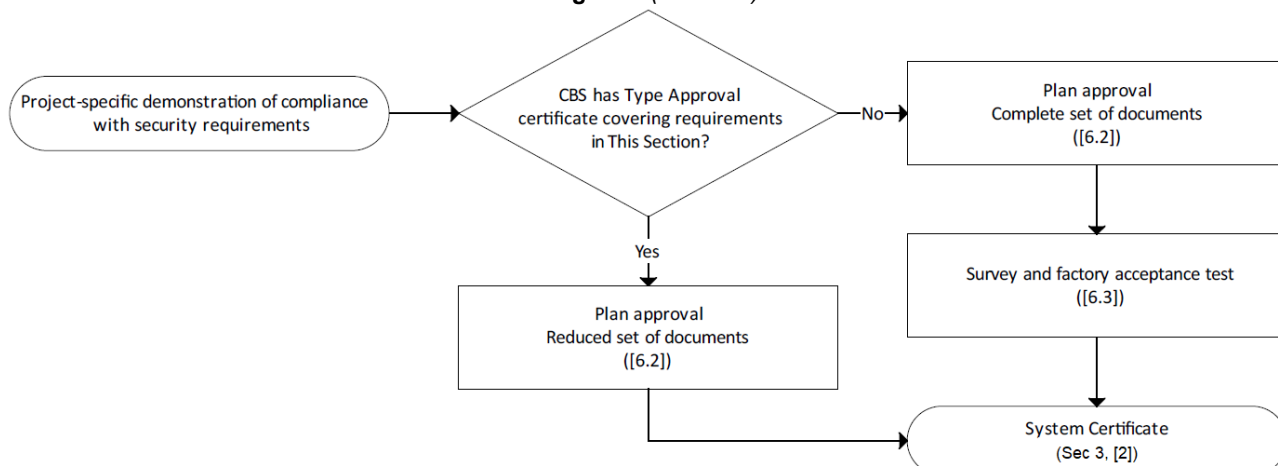

Figure 2 (1/7/2024)



6.2 Plan approval

6.2.1 (1/7/2024)

Plan approval is assessment of documents of a CBS intended for a specific vessel. The documents in [5] are required to be submitted by the supplier. The documents are to enable the Society to verify compliance with requirements in this Section.

If the CBS holds a valid Type approval certificate covering the requirements of this Section, subject to approval by the Society, the supplier may submit a reduced set of vessel-specific documents to the Society (see Tab 3).

The approved version of the documents is to be included in the delivery of the CBS to the system integrator.

6.3 Survey and factory acceptance test

6.3.1 (1/7/2024)

Survey and factory acceptance testing (FAT) is a vessel-specific verification activity required for CBSs that do not hold a valid Type approval certificate covering the requirements of this Section.

The objective of the survey and FAT is to demonstrate by testing and/or analytic evaluation that the CBS complies with applicable requirements in this Section. The survey and FAT are to be carried out at the supplier's premises or at other works having the adequate apparatus for testing and inspection.

After completed plan approval and survey/FAT, the Society will issue a System certificate that is to accompany the CBS upon delivery to the system integrator.

The following subsections specify the survey and FAT activities.

6.3.2 General survey items (1/7/2024)

The supplier is to demonstrate that design, construction, and internal testing has been completed.

It is to also be demonstrated that the system to be delivered is correctly represented by the approved documentation. This is to be done by inspecting the system and comparing

the components and arrangement/architecture with the asset inventory (see [3.1.2]) and the topology diagrams (see [3.1.3]).

6.3.3 Test of security capabilities (1/7/2024)

The supplier is to test the required security capabilities on the system to be delivered. The tests are to be carried out in accordance with the approved test procedure in [3.1.5] and be witnessed/accepted by the Surveyor.

The tests is to provide the Surveyor with reasonable assurance that all requirements are met. This implies that testing of identical components is normally not required.

6.3.4 Correct configuration of security capabilities (1/7/2024)

The supplier is to test/demonstrate for the class surveyor that security settings in the system's components have been configured in accordance with the configuration guidelines in [3.1.6]. This demonstration may be carried out in conjunction with testing of the security capabilities.

The security settings are to be documented in a report, e.g. a ship-specific instance of the configuration guidelines.

6.3.5 Secure development lifecycle (1/7/2024)

The supplier is to, in accordance with documentation in [3.1.7], demonstrate compliance with requirements for secure development lifecycle in [5].

a) Controls for private keys (IEC 62443-4-1/SM-8)

This requirement applies if the system includes software that is digitally signed for the purpose of enabling the user to verify its authenticity.

The supplier is to present management system documentation substantiating that policies, procedures and technical controls are in place to protect generation, storage and use of private keys used for code signing from unauthorized access.

The policies and procedures are to address roles, responsibilities and work processes. The technical controls are to include e.g. physical access restrictions

and cryptographic hardware (e.g. Hardware security module) for storage of the private key.

b) **Security update documentation (IEC 62443-4-1/SUM-2)**

The supplier is to present management system documentation substantiating that a process is established in the organization to ensure security updates are informed to the users. The information to the users are to include the items listed in [5.1.3].

c) **Dependent component security update documentation (IEC 62443-4-1/SUM-3)**

The supplier is to present management system documentation, as required by [5.1.4], substantiating that a process is established in the organization to ensure users are informed whether the system is compatible with updated versions of acquired software in the system (new versions/patches of operating system or firmware). The information are to address how to manage risks related to not applying the updated acquired software.

d) **Security update delivery (IEC 62443-4-1/SUM-4)**

The supplier is to present management system documentation, as required by [5.1.5], substantiating that a process is established in the organization ensuring that system security updates are made available to users, and describing how the user may verify the authenticity of the updated software.

e) **Product defence in depth (IEC 62443-4-1/SG-1)**

The supplier is to present management system documentation, as required by [5.1.6], substantiating that a process is established in the organization to document a strategy for defence-in-depth measures to mitigate security threats to software in the CBS during installation, maintenance and operation.

Examples of threats could be installation of unauthorised software, weaknesses in the patching process, tampering with software in the operational phase of the ship.

f) **Defence in depth measures expected in the environment (IEC 62443-4-1/SG-2)**

The supplier is to present management system documentation, as required by [5.1.7], substantiating that a process is established in the organization to document defence-in-depth measures expected to be provided by the external environment, such as physical arrangement, policies and procedures.

g) **Security hardening guidelines (IEC 62443-4-1/SG-3)**

The supplier is to present management system documentation, as required by [5.1.8], substantiating that a process is established in the organization to ensure that hardening guidelines are produced for the system.

The guidelines are to specify how to reduce vulnerabilities in the system by removal/prohibiting/disabling of unnecessary software, accounts, services, etc.

Table 3 : Documents to be submitted (1/7/2024)

No.	I/A (1)	Document	Requirements
1	A (2), (3)	CBS asset inventory (see [3.1.2])	To be incorporated in Vessel asset inventory (see Sec 4, [4.2.2])
2	A (2), (3)	Topology diagrams (see [3.1.3])	Enabling System integrator to design security zones and conduits (see Sec 4, [4.3.2])
3	A (2)	Description of security capabilities (see [3.1.4])	Required security capabilities (see [4.2])
4			Additional security capabilities, if applicable (see [4.3])
5	A (2)	Test procedure for security capabilities (see [3.1.5])	Required security capabilities (see [4.2])
6			Additional security capabilities, if applicable (see [4.3])
7	I (2)	Security configuration guidelines (see [3.1.6])	Network and security configuration settings (see Tab 1, item 29)
8	A (2)	Secure development lifecycle (see [3.1.7])	SDLC requirements (see [5])
9	I (2)	Plans for maintenance and verification (see [3.1.8])	Security functionality verification (see Tab 1, item 19)
<p>(1) A = to be submitted for approval; I = to be submitted for information.</p> <p>(2) Required for CBS without type approved security capabilities</p> <p>(3) Required for CBS with type approved security capabilities</p>			

No.	I/A (1)	Document	Requirements
10	I (2)	Information supporting incident response and recovery plans (see [3.1.9])	Auditable events (see Tab 1, item 13)
11	I (2)		Deterministic output (see Tab 1, item 20)
12	I (2)		System backup (see Tab 1, item 26)
13	I (2)		System recovery and reconstitution (see Tab 1, item 27)
14	I (2)	Management of change plan (see [3.1.10])	Management of change process (see Sec 3)
15	I (3)	Test reports (see [3.1.11])	Configuration of security capabilities and hardening (see [3.1.6] and [5.1.8])
<p>(1) A = to be submitted for approval; I = to be submitted for information.</p> <p>(2) Required for CBS without type approved security capabilities</p> <p>(3) Required for CBS with type approved security capabilities</p>			

SECTION 6

CONSTRUCTIONAL REQUIREMENTS

1 General

1.1 Construction

1.1.1 Automation systems are to be so constructed as:

- to withstand the environmental conditions, as defined in Ch 2, Sec 2, [1], in which they operate
- to have necessary facilities for maintenance work.

1.2 Materials

1.2.1 Materials are generally to be of the flame-retardant type.

1.2.2 Connectors are to be able to withstand standard vibrations, mechanical constraints and corrosion conditions as given in Sec 8.

1.3 Component design

1.3.1 Automation components are to be designed to simplify maintenance operations. They are to be so constructed as to have:

- easy identification of failures
- easy access to replaceable parts
- easy installation and safe handling in the event of replacement of parts (plug and play principle) without impairing the operational capability of the system, as far as practicable
- facility for adjustment of set points or calibration
- test point facilities, to verify the proper operation of components.

1.4 Environmental and supply conditions

1.4.1 The environmental and supply conditions are specified in Sec 1. Specific environmental conditions are to be considered for air temperature and humidity, vibrations, corrosion from chemicals and mechanical or biological attacks.

2 Electrical and/or electronic systems

2.1 General

2.1.1 Electrical and electronic equipment is to comply with the requirements of Chapter 2 and Chapter 3.

2.1.2 A separation is to be done between any electrical components and liquids, if they are in a same enclosure. Necessary drainage will be provided where liquids are likely to leak.

2.1.3 When plug-in connectors or plug-in elements are used, their contacts are not to be exposed to excessive mechanical loads. They are to be provided with a locking device.

2.1.4 All replaceable parts are to be so arranged that it is not possible to connect them incorrectly or to use incorrect replacements. Where this not practicable, the replacement parts as well as the associated connecting devices are to be clearly identified. In particular, all connection terminals are to be properly tagged. When replacement cannot be carried out with the system on, a warning sign is to be provided.

2.1.5 Forced cooling systems are to be avoided. Where forced cooling is installed, an alarm is to be provided in the event of failure of the cooling system.

2.1.6 The interface connection is to be so designed to receive the cables required. The cables are to be chosen according to Ch 2, Sec 3.

2.2 Electronic system

2.2.1 Printed circuit boards are to be so designed that they are properly protected against the normal aggression expected in their environment.

2.2.2 Electronic systems are to be constructed taking account of electromagnetic interferences.

Special precautions are to be taken for:

- measuring elements such as the analogue amplifier or analog/digital converter; and
- connecting different systems having different ground references.

2.2.3 The components of electronic systems (printed circuit board, electronic components) are to be clearly identifiable with reference to the relevant documentation.

2.2.4 Where adjustable set points are available, they are to be readily identifiable and suitable means are to be provided to protect them against changes due to vibrations and uncontrolled access.

2.2.5 The choice of electronic components is to be made according to the normal environmental conditions, in particular the temperature rating.

2.2.6 All stages of fabrication of printed circuit boards are to be subjected to quality control. Evidence of this control is to be documented.

2.2.7 Burn-in tests or equivalent tests are to be performed.

2.2.8 The programmable components are to be clearly tagged with the program date and reference.

Components are to be protected against outside alteration when loaded.

2.3 Electrical system

2.3.1 Cables and insulated conductors used for internal wiring are to be at least of the flame-retardant type, and are to comply with the requirements in Chapter 2.

2.3.2 If specific products (e.g. oil) are likely to come into contact with wire insulation, the latter is to be resistant to such products or properly shielded from them, and to comply with the requirements in Chapter 2.

3 Pneumatic systems

3.1

3.1.1 Pneumatic automation systems are to comply with Ch 1, Sec 10, [14].

3.1.2 Pneumatic circuits of automation systems are to be independent of any other pneumatic circuit on board.

4 Hydraulic systems

4.1

4.1.1 Hydraulic automation systems are to comply with Ch 1, Sec 10, [14].

4.1.2 Suitable filtering devices are to be incorporated into the hydraulic circuits.

4.1.3 Hydraulic circuits of automation systems are to be independent of any other hydraulic circuit on board.

5 Automation consoles

5.1 General

5.1.1 Automation consoles are to be designed on ergonomic principles. Handrails are to be fitted for safe operation of the console.

5.2 Indicating instruments

5.2.1 The operator is to receive feed back information on the effects of his orders.

5.2.2 Indicating instruments and controls are to be arranged according to the logic of the system in control. In addition, the operating movement and the resulting movement of the indicating instrument are to be consistent with each other.

5.2.3 The instruments are to be clearly labelled. When installed in the wheelhouse, all lighted instruments of consoles are to be dimmable, where necessary.

5.3 VDU's and keyboards

5.3.1 VDU's in consoles are to be located so as to be easily readable from the normal position of the operator. The environmental lighting is not to create any reflection which makes reading difficult.

5.3.2 The keyboard is to be located to give easy access from the normal position of the operator. Special precautions are to be taken to avoid inadvertent operation of the keyboard.

SECTION 7

INSTALLATION REQUIREMENTS

1 General

1.1

1.1.1 Automation systems are to be installed taking into account:

- the maintenance requirements (test and replacement of systems or components)
- the influence of EMI. The IEC 60533 standard is to be taken as guidance
- the environmental conditions corresponding to the location in accordance with Ch 2, Sec 1 and Ch 2, Sec 3, [6].

1.1.2 Control stations are to be arranged for the convenience of the operator.

1.1.3 Automation components are to be properly fitted. Screws and nuts are to be locked, where necessary.

2 Sensors and components

2.1 General

2.1.1 The location and selection of the sensor is to be done so as to measure the actual value of the parameter. Temperature, vibration and EMI levels are to be taken into account. When this is not possible, the sensor is to be designed to withstand the local environment.

2.1.2 The enclosure of the sensor and the cable entry are to be appropriate to the space in which they are located.

2.1.3 Means are to be provided for testing, calibration and replacement of automation components. Such means are to be designed, as far as practicable, so as to avoid perturbation of the normal operation of the system.

2.1.4 A tag number is to identify automation components and is to be clearly marked and attached to the component. These tag numbers are to be collected on the instrument list mentioned in Sec 1, Tab 1.

2.1.5 Electrical connections are to be arranged for easy replacement and testing of sensors and components. They are to be clearly marked.

2.1.6 Low level signal sensors are to be avoided. When installed they are to be located as close as possible to amplifiers, so as to avoid external influences. Failing this, the wiring is to be provided with suitable EMI protection and temperature correction.

2.2 Temperature elements

2.2.1 Temperature sensors, thermostats or thermometers are to be installed in a thermowell of suitable material, to permit easy replacement and functional testing. The thermowell is not to significantly modify the response time of the whole element.

2.3 Pressure elements

2.3.1 Three-way valves or other suitable arrangements are to be installed to permit functional testing of pressure elements, such as pressure sensors, pressure switches or pressure gauges, without stopping the installation.

2.3.2 In specific applications, where high pulsations of pressure are likely to occur, a damping element, such as a capillary tube or equivalent, is to be installed.

2.4 Level switches

2.4.1 Level switches fitted to flammable oil tanks, or similar installations, are to be installed so as to reduce the risk of fire.

3 Cables

3.1 Installation

3.1.1 Cables are to be installed according to the requirements in Ch 2, Sec 12, [7].

3.1.2 Suitable installation features such as screening and/or twisted pairs and/or separation between signal and other cables are to be provided in order to avoid possible interference on control and instrumentation cables.

3.1.3 Specific transmission cables (coaxial cables, twisted pairs, etc.) are to be routed in specific cable-ways and mechanically protected to avoid loss of any important transmitted data. Where there is a high risk of mechanical damage, the cables are to be protected with pipes or equivalent.

3.1.4 The cable bend radius is to be in accordance with the requirements of Ch 2, Sec 12, [7.2].

For mineral insulated cables, coaxial cables or fibre optic cables, whose characteristics may be modified, special precautions are to be taken according to the manufacturer's instructions.

3.2 Cable terminations

3.2.1 Cable terminations are to be arranged according to the requirements in Chapter 2. Particular attention is to be paid to the connections of cable shields. Shields are to be

connected only at the sensor end when the sensor is earthed, and only at the processor end when the sensor is floating.

3.2.2 Cable terminations are to be able to withstand the identified environmental conditions (shocks, vibrations, salt mist, humidity, etc.).

3.2.3 Terminations of all special cables such as mineral insulated cables, coaxial cables or fibre optic cables are to be arranged according to the manufacturer's instructions.

4 Pipes

4.1

4.1.1 For installation of piping circuits used for automation purposes, see the requirements in Ch 1, Sec 10.

4.1.2 As far as practicable, piping containing liquids is not to be installed in or adjacent to electrical enclosures (see Sec 6, [2.1.2]).

4.1.3 Hydraulic and pneumatic piping for automation systems is to be marked to indicate its function.

5 Automation consoles

5.1 General

5.1.1 Consoles or control panels are to be located so as to enable a good view of the process under control, as far as practicable. Instruments are to be clearly readable in the ambient lighting.

5.1.2 The location is to be such as to allow easy access for maintenance operations.

SECTION 8

TESTING

1 General

1.1 Commissioning

1.1.1 Automation systems are to be tested for type approval, acceptance or commissioning, when required. Tests are to be carried out under the supervision of a Surveyor of the Society.

1.1.2 The type testing conditions for electrical, control and instrumentation equipment, computers and peripherals are described in [2].

1.1.3 Automation systems are to be inspected at works, according to the requirements of [3], in order to check that the construction complies with the Rules.

1.1.4 Automation systems are to be commissioned when installed on board and prior to sea trials, to verify their performance and adaptation on site, according to [4].

2 Type approval

2.1 General

2.1.1 (1/1/2016)

This test specification for type approval is applicable, but not confined, to electrical, electronic and programmable equipment intended for (see Note 1a):

- control, monitoring, alarm and protection systems for use in ships
- internal communication.

Note 1:

- a) These test requirements are harmonised with IEC 60092-504 "Electrical Installations in Ships -Part 504: Special features - Control and Instrumentation" and IEC 60533 "Electrical and electronic installations in ships - Electromagnetic compatibility". Electrical and electronic equipment on board ships, required neither by the Rules nor by International Conventions, liable to cause electromagnetic disturbance are to be of type

which fulfill the test requirements of test specification items 19 and 20 of Tab 1.

- b) Functional test, as used in Tab 1, is a simplified test sufficient to verify that the equipment under test (EUT) has not suffered any deterioration caused by the individual environmental tests and not a complete performance test as required in item 2 of Tab 1.

2.1.2 The necessary documents to be submitted, prior to type testing, are listed in Sec 1, [2.4.1]. The type approval of automation systems refers to hardware type approval or software type approval, as applicable.

2.2 Hardware type approval

2.2.1 (1/1/2002)

These tests are to demonstrate the ability of the equipment to function as intended under the specified testing conditions.

The extent of the testing, i.e. the selection and sequence of tests and the number of pieces to be tested is to be determined upon examination and evaluation of the equipment or component subject to testing giving due regard to its intended use.

Equipment is to be tested in its normal position unless otherwise specified in the test specification.

The relevant tests are listed in Tab 1.

2.2.2 The following additional tests may be required, depending on particular manufacturing or operational conditions:

- mechanical endurance test
- temperature shock test (e.g. 12 shocks on exhaust gas temperature sensors from 20°C ± 5°C to maximum temperature of the range)
- immersion test
- oil resistance test
- shock test.

The test procedure is to be defined with the Society in each case.

Table 1 : Type tests (1/7/2024)

No.	Test	Procedure (1)	Test parameters	Other information
1	Visual inspection			<ul style="list-style-type: none"> conformance to drawings, design data.
2	Performance test	<p>Manufacturer performance test programme based upon specification and relevant Rule requirements.</p> <p>When the EUT is required to comply with an international performance standard, e.g. protection relays, verification of requirements in the standard are to be part of the performance testing required in this initial test and subsequent performance tests after environmental testing where required in this Tab 1.</p>	<ul style="list-style-type: none"> standard atmosphere condition temperature: 25°C ± 10°C relative humidity: 60% ± 30% air pressure: 96 KPa ± 10 KPa 	<ul style="list-style-type: none"> confirmation that operation is in accordance with the requirements specified for particular system or equipment checking of self-monitoring features checking of specified protection against an access to the memory checking against effect an erroneous use of control elements in the case of computer systems
3	External power supply failure		<ul style="list-style-type: none"> 3 interruptions during 5 minutes switching- off time 30 s each case 	<ul style="list-style-type: none"> The time of 5 minutes may be exceeded if the equipment under test needs a longer time for start up, e.g. booting sequence For equipment which requires booting, one additional power supply interruption during booting to be performed <p>Verification of:</p> <ul style="list-style-type: none"> equipment behaviour upon loss and restoration of supply; possible corruption of programme or data held in programmable electronic systems, where applicable.

No.	Test	Procedure (1)	Test parameters	Other information																																	
4	Power supply variations a) Electric		<p style="text-align: center;">AC SUPPLY</p> <table border="1"> <thead> <tr> <th>Combination</th> <th>Voltage variation</th> <th>Frequency variation</th> </tr> </thead> <tbody> <tr> <td>1</td> <td>permanent</td> <td>permanent</td> </tr> <tr> <td>2</td> <td>+ 6%</td> <td>+ 5%</td> </tr> <tr> <td>3</td> <td>+ 6%</td> <td>- 5%</td> </tr> <tr> <td>4</td> <td>- 10%</td> <td>- 5%</td> </tr> <tr> <td></td> <td>- 10%</td> <td>+ 5%</td> </tr> <tr> <td></td> <td>voltage transient</td> <td>frequency transient</td> </tr> <tr> <td></td> <td>1,5 s</td> <td>5 s</td> </tr> <tr> <td>5</td> <td>%</td> <td>%</td> </tr> <tr> <td>6</td> <td>+ 20%</td> <td>+ 10%</td> </tr> <tr> <td></td> <td>- 20%</td> <td>- 10%</td> </tr> </tbody> </table>	Combination	Voltage variation	Frequency variation	1	permanent	permanent	2	+ 6%	+ 5%	3	+ 6%	- 5%	4	- 10%	- 5%		- 10%	+ 5%		voltage transient	frequency transient		1,5 s	5 s	5	%	%	6	+ 20%	+ 10%		- 20%	- 10%	
			Combination	Voltage variation	Frequency variation																																
1	permanent	permanent																																			
2	+ 6%	+ 5%																																			
3	+ 6%	- 5%																																			
4	- 10%	- 5%																																			
	- 10%	+ 5%																																			
	voltage transient	frequency transient																																			
	1,5 s	5 s																																			
5	%	%																																			
6	+ 20%	+ 10%																																			
	- 20%	- 10%																																			
<p style="text-align: center;">DC SUPPLY</p> <p>Voltage tolerance continuous: $\pm 10\%$ Voltage cyclic variation: 5% Voltage ripple: 10%</p> <p>Electric battery supply:</p> <ul style="list-style-type: none"> +30% to -25% for equipment connected to charging battery or as determined by the charging/discharging characteristics, including ripple voltage from the charging device; +20% to -25% for equipment not connected to the battery during charging 																																					
	b) Pneumatic and hydraulic		Pressure: $\pm 20\%$ Duration: 15 minutes																																		
5	Dry heat (see (2))	IEC 60068-2-2 Test Bb for non-heat dissipating equipment	<ul style="list-style-type: none"> Temperature: $55^{\circ}\text{C} \pm 2^{\circ}\text{C}$ Duration: 16 hours, or Temperature: $70^{\circ}\text{C} \pm 2^{\circ}\text{C}$ Duration: 16 hours 	<ul style="list-style-type: none"> equipment operating during conditioning and testing functional test (see [2.1.1] Note 1b)) during the last hour at the test temperature for equipment specified for increased temperature the dry heat test is to be conducted at the agreed test temperature and duration. 																																	
		IEC 60068-2-2 Test Be for heat dissipating equipment	<ul style="list-style-type: none"> Temperature: $55^{\circ}\text{C} \pm 2^{\circ}\text{C}$ Duration: 16 hours, or Temperature: $70^{\circ}\text{C} \pm 2^{\circ}\text{C}$ Duration: 16 hours 	<ul style="list-style-type: none"> equipment operating during conditioning and testing with cooling system on if provided functional test (see [2.1.1] Note 1b)) during the last hour at the test temperature for equipment specified for increased temperature the dry heat test is to be conducted at the agreed test temperature and duration 																																	

No.	Test	Procedure (1)	Test parameters	Other information
6	Damp heat	IEC 60068-2-30 Test D _b	Temperature: 55°C Humidity: 95% Duration: 2 cycles 2 x (12 + 12 hours)	<ul style="list-style-type: none"> measurement of insulation resistance before test the test is to start with 25°C ± 3°C and at least 95% humidity equipment operating during the complete first cycle and switched off during second cycle except for functional test functional test during the first 2 hours of the first cycle at the test temperature and during the last 2 hours of the second cycle at the test temperature; duration of the second cycle can be extended due to more convenient management of the functional test recovery at standard atmosphere conditions insulation resistance measurements and performance test
7	Vibration	IEC 60068-2-6 Test F _c	<ul style="list-style-type: none"> 2 Hz ± 3/0 Hz to 13,2 Hz – amplitude: ± 1mm 13,2 Hz to 100 Hz – acceleration: ± 0,7 g <p>For severe vibration conditions such as, e. g., on diesel engines, air compressors, etc.:</p> <ul style="list-style-type: none"> 2,0 Hz to 25 Hz – amplitude: ± 1,6 mm 25 Hz to 100 Hz – acceleration: ± 4,0 g <p>Note: More severe conditions may exist for example on exhaust manifolds or fuel oil injection systems of diesel engines. For equipment specified for increased vibration levels the vibration test is to be conducted at the agreed vibration level, frequency range and duration. Values may be required to be in these cases 40 Hz to 2000 Hz - acceleration: ± 10,0 g at 600°C, duration 90 min.</p>	<ul style="list-style-type: none"> duration in case of no resonance condition 90 minutes at 30 Hz; duration at each resonance frequency at which $Q \geq 2$ is recorded - 90 minutes; during the vibration test, functional tests are to be carried out; tests to be carried out in three mutually perpendicular planes; it is recommended as a guidance that Q does not exceed 5. where sweep test is to be carried out instead of the discrete frequency test and a number of resonant frequencies are detected close to each other, duration of the test is to be 120 min. Sweep over a restricted frequency range between 0,8 and 1,2 times the critical frequencies can be used where appropriate. <p>Note: Critical frequency is a frequency at which the equipment being tested may exhibit:</p> <ul style="list-style-type: none"> malfunction and/or performance deterioration mechanical resonances and/or other response effects occur, e.g. chatter

No.	Test	Procedure (1)	Test parameters	Other information
10	High voltage	Rated voltage U_n (V) Up to 65 66 to 250 251 to 500 501 to 690	Test voltage (V) (A.C. voltage 50 or 60Hz) $2 \times U_n + 500$ 1500 2000 2500	For high voltage equipment, reference is made to Ch 2, Sec 13. <ul style="list-style-type: none"> • separate circuits are to be tested against each other and all circuits connected with each other tested against earth; • printed circuits with electronic components may be removed during the test; • period of application of the test voltage: 1 minute
11	Cold	IEC 60068-2-1	<ul style="list-style-type: none"> • Temperature: $+5^\circ\text{C} \pm 3^\circ\text{C}$ Duration: 2 hours, or • Temperature: $-25^\circ\text{C} \pm 3^\circ\text{C}$ Duration: 2 hours (see (3)) 	<ul style="list-style-type: none"> • initial measurement of insulation resistance; • equipment not operating during conditioning and testing except for operational test; • operational test during the last hour at the test temperature; • insulation resistance measurement and the operational test after recovery
12	Salt mist	IEC 60068-2-52 Test Kb	Four spraying periods with a storage of seven days after each.	<ul style="list-style-type: none"> • initial measurement of insulation resistance and initial functional test • equipment not operating during conditioning • functional test on the 7th day of each storage period • insulation resistance measurement and performance test 4 to 6h after recovery (see (4)) • on completion of exposure, the equipment shall be examined to verify that deterioration or corrosion (if any) is superficial in nature
13	Electrostatic discharge	IEC 61000-4-2	Contact discharge: 6 kV Air discharge: 2kV, 4kV, 8 kV Interval between single discharges: 1 s. No. of pulses: 10 per polarity According to test level 3	<ul style="list-style-type: none"> • to simulate electrostatic discharge as may occur when persons touch the appliance • the test is to be confined to the points and surfaces that can normally be reached by the operator • performance Criterion B (see (5))

No.	Test	Procedure (1)	Test parameters	Other information
14	Electromagnetic field	IEC 61000-4-3 or IEC 61000-4-3+AMD1+AMD2	Frequency range: 80 MHz - 6 GHz Modulation ^{**} : 80% AM at 1000Hz Field strength: 10V/m Frequency sweep rate: ≤ 1,5.10 ⁻³ decades/s (or 1% / 3 s) According to test level 3	<ul style="list-style-type: none"> to simulate electromagnetic fields radiated by different transmitters the test is to be confined to the appliances exposed to direct radiation by transmitters at their place of installation performance criterion A (see (6)). <p>^{**} If, for tests of equipment, an input signal with a modulation frequency of 1000 Hz is necessary, a modulation frequency of 400 Hz may be chosen</p> <ul style="list-style-type: none"> If an equipment is intended to receive radio signals for the purpose of radio communication (e.g. wi-fi router, remote radio controller), then the immunity limits at its communication frequency do not apply, subject to the provisions "Specific requirements for wireless data links" in Sec 3.
15	Conducted low frequency		<p>A.C.:</p> <ul style="list-style-type: none"> Frequency range: rated frequency to 200th harmonic Test voltage (rms): 10% of supply to 15th harmonic reducing to 1% at 100th harmonic and maintain this level to the 200th harmonic, min 3 V rms Max 2 W <p>D.C.:</p> <ul style="list-style-type: none"> Frequency range: 50 Hz - 10 kHz Test voltage (rms) :10% of supply max. 2 W 	<ul style="list-style-type: none"> to simulate distortions in the power supply system generated for instance, by electronic consumers and coupled in as harmonics performance criterion A (see (6)) See Figure in Notes in this Table to keep max. 2W, the voltage of the test signal may be lower.
16	Conducted Radio Frequency	IEC 61000-4-6	AC, DC, I/O ports and signal/control lines: Frequency range: 150 kHz - 80 MHz Amplitude: 3 V rms (see (7)) Modulation ^{***} : 80% AM at 1000 Hz Frequency sweep rate: ≤1,5.10 ⁻³ decades/s (or 1% / 3sec.) According to test level 2	<ul style="list-style-type: none"> Equipment design and the choice of materials is to simulate electromagnetic fields coupled as high frequency into the test specimen via the connecting lines performance criterion A (see (6)). <p>^{***} If, for tests of equipment, an input signal with a modulation frequency of 1000 Hz is necessary, a modulation frequency of 400 Hz may be chosen</p>
17	Electrical Fast Transients / Burst	IEC 61000-4-4	Single pulse time: 5ns (between 10% and 90% value) Single pulse width: 50 ns (50% value) Amplitude (peak): 2 kV line on power supply port/earth; 1 kV on I/O data control and communication ports (coupling clamp) Pulse period: 300 ms Burst duration: 15 ms Duration/polarity: 5 min According to test level 3	<ul style="list-style-type: none"> arcs generated when actuating electrical contacts interface effect occurring on the power supply, as well as at the external wiring of the test specimen performance criterion B (see (5))

No.	Test	Procedure (1)	Test parameters	Other information																				
18	Surge	IEC 61000-4-5	<p>Test applicable to AC and DC power ports</p> <p>Open-circuit voltage:</p> <p>Pulse rise time: 1,2 μs (front time)</p> <p>Pulse width: 50 μs (time to half value)</p> <p>Amplitude (peak) :</p> <p>1 kV line/earth; 0,5 kV line/line</p> <p>Short-circuit current:</p> <p>Pulse rise time: 8 μs (front time)</p> <p>Pulse width: 20 μs (time to half value)</p> <p>Repetition rate: \geq 1 pulse/min</p> <p>No of pulses: 5 per polarity</p> <p>Application: continuous</p> <p>According to test level 2</p>	<ul style="list-style-type: none"> interference generated for instance, by switching "ON" or "OFF" high power inductive consumers test procedure in accordance with figure 10 of the standard for equipment where power and signal lines are identical performance criterion B (see (5)) 																				
19	Radiated Emission	CISPR 16-2-3 IEC 60945 for 156-165 MHz	<p>Limits below 1000 MHz</p> <p>For equipment installed in the bridge and deck zone:</p> <table border="0"> <thead> <tr> <th>Frequency range:</th> <th>Quasi peak limits:</th> </tr> </thead> <tbody> <tr> <td>0,15 - 0,30 MHz</td> <td>80 - 52 dBμV/m</td> </tr> <tr> <td>0,30 - 30 MHz</td> <td>52 - 34 dBμV/m</td> </tr> <tr> <td>30 - 1000 MHz</td> <td>54 dBμV/m</td> </tr> </tbody> </table> <p>except for:</p> <table border="0"> <tbody> <tr> <td>156 - 165 MHz</td> <td>24 dBμV/m</td> </tr> </tbody> </table> <p>For equipment installed in the general power distribution zone:</p> <table border="0"> <thead> <tr> <th>Frequency range:</th> <th>Quasi peak limits:</th> </tr> </thead> <tbody> <tr> <td>0,15 - 30 MHz</td> <td>80 - 50 dBμV/m</td> </tr> <tr> <td>30 - 100 MHz</td> <td>60 - 54 dBμV/m</td> </tr> <tr> <td>100 - 1000 MHz</td> <td>54 dBμV/m</td> </tr> </tbody> </table> <p>except for:</p> <table border="0"> <tbody> <tr> <td>156 - 165 MHz</td> <td>24 dBμV/m</td> </tr> </tbody> </table> <p>Limits above 1000 MHz</p> <p>Frequency range:</p> <p>Average limit:</p> <p>1000 - 6000 MHz</p> <p>54 dBμV/m</p>	Frequency range:	Quasi peak limits:	0,15 - 0,30 MHz	80 - 52 dB μ V/m	0,30 - 30 MHz	52 - 34 dB μ V/m	30 - 1000 MHz	54 dB μ V/m	156 - 165 MHz	24 dB μ V/m	Frequency range:	Quasi peak limits:	0,15 - 30 MHz	80 - 50 dB μ V/m	30 - 100 MHz	60 - 54 dB μ V/m	100 - 1000 MHz	54 dB μ V/m	156 - 165 MHz	24 dB μ V/m	<ul style="list-style-type: none"> procedure in accordance with the standard but distance 3 m between equipment and antenna for the frequency band 156 MHz to 165 MHz the measurement is to be repeated with a receiver bandwidth of 9 kHz (as per IEC 60945) alternatively the radiation limit at a distance of 3 m from the enclosure port over the frequency 156 MHz to 165 MHz is to be 30 dB micro-V/m peak (as per IEC 60945). procedure in accordance with the standard (distance 3 m between equipment and antenna) equipment intended to transmit radio signals for the purpose of radio communication (e.g. wi-fi router, remote radio controller) may be exempted from limit, within its communication frequency range, subject to the provisions "Specific requirements for wireless data links" in Sec 3, [7.3.2].
Frequency range:	Quasi peak limits:																							
0,15 - 0,30 MHz	80 - 52 dB μ V/m																							
0,30 - 30 MHz	52 - 34 dB μ V/m																							
30 - 1000 MHz	54 dB μ V/m																							
156 - 165 MHz	24 dB μ V/m																							
Frequency range:	Quasi peak limits:																							
0,15 - 30 MHz	80 - 50 dB μ V/m																							
30 - 100 MHz	60 - 54 dB μ V/m																							
100 - 1000 MHz	54 dB μ V/m																							
156 - 165 MHz	24 dB μ V/m																							
20	Conducted Emission	CISPR 16-2-1	<p>Test applicable to AC and DC power ports</p> <p>For equipment installed in the bridge and deck zone:</p> <table border="0"> <thead> <tr> <th>Frequency range:</th> <th>Limits:</th> </tr> </thead> <tbody> <tr> <td>10 - 150 kHz</td> <td>96 - 50 dBμV</td> </tr> <tr> <td>150 - 350 kHz</td> <td>60 - 50 dBμV</td> </tr> <tr> <td>0,35 - 30 MHz</td> <td>50 dBμV</td> </tr> </tbody> </table> <p>For equipment installed in the general power distribution zone:</p> <table border="0"> <thead> <tr> <th>Frequency range:</th> <th>Limits:</th> </tr> </thead> <tbody> <tr> <td>10 - 150 kHz</td> <td>120 - 69 dBμV</td> </tr> <tr> <td>150 - 500 kHz</td> <td>79 dBμV</td> </tr> <tr> <td>0,5 - 30 MHz</td> <td>73 dBμV</td> </tr> </tbody> </table>	Frequency range:	Limits:	10 - 150 kHz	96 - 50 dB μ V	150 - 350 kHz	60 - 50 dB μ V	0,35 - 30 MHz	50 dB μ V	Frequency range:	Limits:	10 - 150 kHz	120 - 69 dB μ V	150 - 500 kHz	79 dB μ V	0,5 - 30 MHz	73 dB μ V					
Frequency range:	Limits:																							
10 - 150 kHz	96 - 50 dB μ V																							
150 - 350 kHz	60 - 50 dB μ V																							
0,35 - 30 MHz	50 dB μ V																							
Frequency range:	Limits:																							
10 - 150 kHz	120 - 69 dB μ V																							
150 - 500 kHz	79 dB μ V																							
0,5 - 30 MHz	73 dB μ V																							

No.	Test	Procedure (1)	Test parameters	Other information
21	Flame retardant	IEC 60092-101 or IEC 60695-11-5	Flame application: 5 times 15 s each Interval between each application: 15 s or one time 30 s. Test criteria based upon application. The test is performed with the EUT or housing of the EUT applying needle-flame test method.	<ul style="list-style-type: none"> the burnt out or damaged part of the specimen by not more than 60mm long no flame, no incandescence or in the event of a flame or incandescence being present, it is to extinguish itself within 30 s of the removal of the needle flame without full combustion of the test specimen any dripping material is to extinguish itself in such a way as not to ignite a wrapping tissue. The drip height is 200 mm ± 5 mm.

- (1) Column 3 indicates the testing procedure which is normally to be applied. However, equivalent testing procedure may be accepted by the Society provided that what required in the other columns is fulfilled. Later versions (including revisions) of the international standards specified in this Section are acceptable for use provided the Society determines them to be equivalent to the technical specifications of this Section.
- (2) Dry heat at 70 °C is to be carried out to automation, control and instrumentation equipment subject to high degree of heat, for example mounted in consoles, housings, etc. together with other heat dissipating power equipment.
- (3) For equipment installed in non-weather protected locations or cold locations test is to be carried out at -25°C.
- (4) Salt mist test is to be carried out for equipment installed in weather exposed areas.
- (5) Performance Criterion B: (for transient phenomena): the EUT is to continue to operate as intended after the tests. No degradation of performance or loss of function is allowed as defined in the technical specification published by the Manufacturer. During the test, degradation or loss of function or performance which is self recoverable is however allowed but no change of actual operating state or stored data is allowed.
- (6) Performance Criterion A (for continuous phenomena): the Equipment Under Test is to continue to operate as intended during and after the test. No degradation of performance or loss is allowed as defined in relevant equipment standard and the technical specification published by the Manufacturer.
- (7) For equipment installed on the bridge and deck zone, the test levels are to be increased to 10V rms for spot frequencies in accordance with IEC 60945 at 2; 3; 4; 6.2; 8.2; 12.6; 16.5; 18.8; 22; 25 MHz.

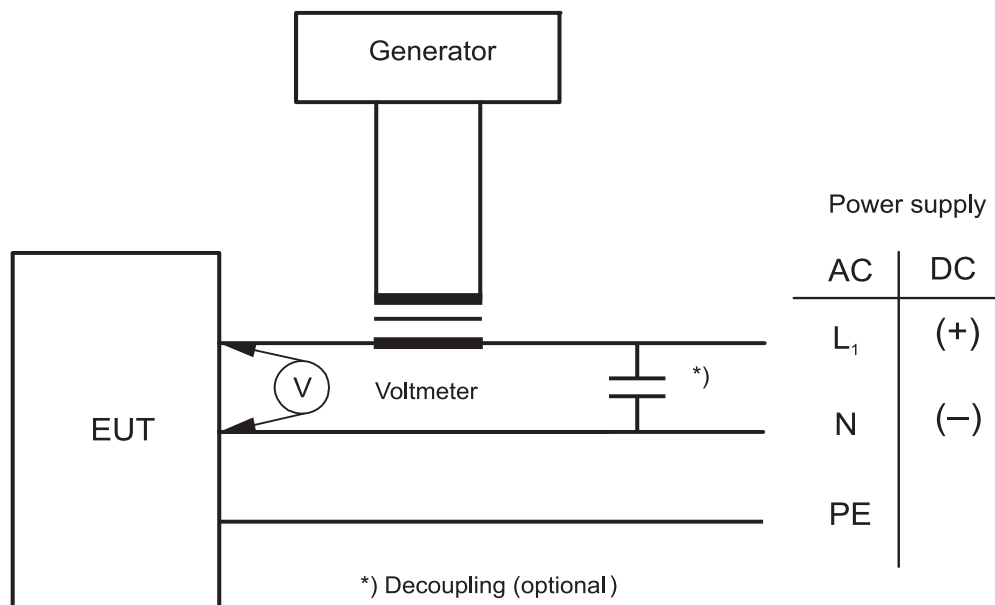

2.3 Software type approval

2.3.1 Software type approval consists of evaluation of the development quality and verification of test results.

Documents in accordance with Tab 2 are required to demonstrate the development quality.

Repetition of unit tests, integration tests or validation tests is required to verify the consistency of test results.

Certificate may be issued at the request of the manufacturer when approval is granted.

2.3.2 For programmable electronic systems, as a guidance, the documents to be submitted for information are listed in Tab 2.

2.3.3 The software type approval applies only to basic software of the programmable electronic system.

The basic software approval is carried out in the following phases:

- Examination of the documents as required in Sec 1, [2.3.2],
- Verification that all the development work has been carried out according to the quality procedure. The complementary documents required in Tab 2 prove the quality of the development work.

Note 1: Particular attention will be given to the test results collected on unit testing file, integration test file and validation test file

- Repetition of tests of the essential function of the software. Comparison with documentation containing the test results of previous tests is to be carried out.

2.3.4 The application software is to be approved on a case by case basis, according to [3.3.2].

2.4 Navigational and radio equipment

2.4.1 (1/1/2002)

The test conditions as specified in IEC 60945 (marine navigational and radiocommunication equipment and systems - general requirements, methods of testing and required test results) are to be applied for the above-mentioned equipment.

2.5 Loading instruments

2.5.1 (1/1/2017)

Loading instrument approval consists of:

- approval of hardware according to [2.2], unless two computers are available on board for loading calculations only
- for programmable loading instruments, approval of basic software according to [2.3]
- approval of application software, consisting in data verification which results in the Endorsed Test Condition according to Part B
- installation testing according to [4].

Table 2 : Basic software development documents

No.	I/A (2)	DOCUMENT
1	I	Follow-up of developed software: identification, safeguard, storage
2	I	Document showing the capability and training of the development team
3	I	Production of a specification file
4	I	Production of a preliminary design file
5	I	Production of a detailed design file
6	I	Production of a coding file
7	I	Production of a unit testing file (1)
8	I	Production of an integration test file (1)
9	I	Production of a validation test file (1)
10	I	Production of a maintenance facility file
11	I	Production of a quality plan
12	I	Follow-up of the quality plan: checks, audits, inspections, reviews
(1) Complementary test carried out, at random, at the request of the Surveyor		
(2) A : to be submitted for approval; I : to be submitted for information.		

3 Acceptance testing

3.1 General

3.1.1 Acceptance tests are generally to be carried out at the manufacturer's facilities before the shipment of the equipment.

Acceptance tests refer to hardware and software tests as applicable.

3.2 Hardware testing

3.2.1 Hardware acceptance tests include, where applicable:

- visual inspection
- operational tests and, in particular:
 - tests of all alarm and safety functions
 - verification of the required performance (range, calibration, repeatability, etc.) for analogue sensors
 - verification of the required performance (range, set points, etc.) for on/off sensors
 - verification of the required performance (range, response time, etc.) for actuators
 - verification of the required performance (full scale, etc.) for indicating instruments
- high voltage test
- hydrostatic tests.

Additional tests may be required by the Society.

3.2.2 Final acceptance will be granted subject to:

- the results of the tests listed in [3.2.1]
- the type test report or type approval certificate.

3.3 Software testing

3.3.1 Software acceptance tests of programmable electronic systems are to be carried out to verify their adaptation to their use on board, and concern mainly the application software.

3.3.2 The software modules of the application software are to be tested individually and subsequently subjected to an integration test. The test results are to be documented and to be part of the final file. It is to be checked that:

- the development work has been carried out in accordance with the plan
- the documentation includes the proposed tests, the acceptance criteria and the result.

Repetition tests may be required to verify the consistency of test results.

3.3.3 Software acceptance will be granted subject to:

- examination of the available documentation
- a functional test of the whole system.

The Society may ask for additional tests of systems which are part of safety systems or which integrate several functions.

4 Commissioning

4.1 General

4.1.1 Commissioning tests are to be carried out on automation systems associated with essential services to verify their compliance with the Rules, by means of visual inspection and the performance and functionality according to Tab 3.

When completed, automation systems are to be such that a single failure, for example loss of power supply, is not to result in a major degradation of the propulsion or steering of the ship. In addition, a blackout test is to be carried out to show that automation systems are continuously supplied.

Upon completion of commissioning tests, test reports are to be made available to the Surveyor.

Table 3 : Commissioning tests

Equipment	Nature of tests
Electronic equipment	Main hardware functionality
Analogue sensors	Signal calibration, trip set point adjustment
On/off sensors	Simulation of parameter to verify and record the set points
Actuators	Checking of operation in whole range and performance (response time, pumping)
Reading instruments	Checking of calibration, full scale and standard reference value

Part C
Machinery, Systems and Fire Protection

Chapter 4

FIRE PROTECTION, DETECTION AND EXTINCTION

**SECTION 1 REQUIREMENTS FOR FIRE PROTECTION, DETECTION AND
EXTINCTION**

SECTION 1 REQUIREMENTS FOR FIRE PROTECTION, DETECTION AND EXTINCTION

1 General

1.1 Purpose and application

1.1.1 (1/1/2007)

This Section applies to cargo ships and passenger ships for which classification is requested.

Note 1: As from 1 January 2007, the statutory requirements of the SOLAS Convention and/or national safety regulations, as applicable, regarding fire protection, detection and extinction (hereinafter referred to as "fire protection statutory requirements") are no longer mandatory for the purpose of classification except where the Society carries out surveys relevant to fire protection statutory requirements on behalf of the flag Administration. In such cases, fire protection statutory requirements are considered a matter of class and therefore compliance with these requirements is also verified by the Society for classification purposes. In general, only IACS Unified Requirements in force related to fire protection, detection and extinction have been retained as Rule requirements within the scope of classification and are contained in this Chapter 4.

1.1.2 (1/1/2007)

[2]; [3]; [4]; [5.1]; [5.3]; [6]; [7]; [8] apply to all ships.

1.1.3 (1/1/2007)

[5.2]; [8]; [9] apply to cargo ships only.

1.1.4 (1/1/2007)

Requirements for tankers in this Section apply to tankers carrying oil having a flashpoint not exceeding 60°C (closed cup test).

1.1.5 (1/1/2007)

Unless otherwise stated, for materials and design criteria of piping and relevant accessories reference is to be made to Ch 1, Sec 10.

2 Documentation to be submitted

2.1

2.1.1 (1/1/2007)

The Interested Party is to submit to the Society the documents listed in Tab 1.

Table 1 : Documentation to be submitted (1/7/2012)

No.	I/A (1)	Document (2)
1	A	Ventilation systems in cargo area of tankers, excluding cargo tanks
2	A	Automatic fire detection systems in unattended machinery spaces
3	A	Arrangement of local application fixed fire-extinguishing systems (2) and inert gas systems
4	A	Gas detection systems on tankers
5	A	Fixed fire-extinguishing system in scavenge spaces of two-stroke crosshead type engines, according to the requirements of Ch 1, Sec 2, [4.4.1]
6	A	Electrical diagram of local application fixed gas fire-extinguishing systems
7	I	General arrangement plan

(1) A : to be submitted for approval, in four copies I : to be submitted for information, in duplicate.
(2) Plans are to be schematic and functional and to contain all information necessary for their correct interpretation and verification such as:

- service pressures
- capacity and head of pumps and compressors, if any
- materials and dimensions of piping and associated fittings
- volumes of protected spaces
- surface areas of protected zones for pressure water-spraying systems
- type, number and location of nozzles of extinguishing media for gas and pressure water-spraying systems.

All or part of the information may be provided, instead of on the above plans, in suitable operation manuals or in specifications of the systems.

3 Definitions

3.1 Accommodation spaces

3.1.1 (1/1/2007)

Accommodation spaces are those spaces used for public spaces, corridors, stairs, lavatories, cabins, offices, hospitals, cinemas, games and hobby rooms, barber shops, pantries containing no cooking appliances and similar spaces.

3.2 Airlock

3.2.1 (1/7/2022)

An airlock is a space enclosed by gastight steel bulkheads with two gastight doors spaced not more than 2,5 m apart. The doors are to be self-closing without any holding back arrangements. Air locks are to have mechanical ventilation and are not to be used for other purposes. An audible and visual alarm system to give a warning on both sides of the air lock is to be provided to indicate if more than one door is moved from the closed position. The air lock space is to be monitored for dangerous gas as defined in Ch 1, App 8, [2.1.3].

3.3 Ballast Water Management System (BWMS)

3.3.1 (1/7/2022)

Ballast Water Management System means any system defined in Ch 1, App 8, [2.1.1].

3.4 Ballast Water Management Room (BWMR)

3.4.1 (1/7/2022)

Ballast Water Management Room is any space containing equipment belonging to the Ballast Water Management System. A space containing remote controls for the BWMS or a space dedicated to the storage of liquid or solid chemicals for BWMS need not be considered as a BWMR.

3.5 BWMS storing, introducing or generating chemicals

3.5.1 (1/7/2022)

In general, BWMS storing, introducing or generating chemicals refer to:

- In-line flocculation (cat.2 as per Ch 1, App 8, Tab 1)
- Chemical injection (cat.6 as per Ch 1, App 8, Tab 1), and
- BWMS technologies using neutralizers injection (cat.4, 5, 6 and 7 as per Ch 1, App 8, Tab 1).

BWMS that do not store, introduce or generate toxic or flammable chemicals may be specially considered as detailed in Tab 2.

Table 2 : Requirements that may be reduced for BWMS storing, introducing or generating chemicals depending on the chemicals (1/7/2022)

Requirement	Conditions to be met before reducing the requirement
[10.2.3] d)	The stored chemicals are neither toxic nor flammable
[10.3.1]	The BWMS does not use any flammable or toxic chemical substances
[10.3.3]	No dangerous gas as defined in Ch 1, App 8, [2.1.3] will be generated by the BWMS
[10.6.1] a)	No toxic chemical is stored and no toxic gas will be generated by the BWMS
[10.7.1] a), c), f)	No toxic chemical is used or will be generated by the BWMS

The IMO reports issued during the basic and final approval procedures of the BWMS that make use of active substances (G9 Guidelines) and "safety hazard" as listed in Ch.17 of IMO IBC code are to be considered for this purpose.

Note 1: Chemicals include additives for BWMS.

3.6 Cargo area

3.6.1 (1/1/2007)

The cargo area is that part of the ship that contains cargo holds, cargo tanks, slop tanks and cargo pump rooms including pump rooms, cofferdams, ballast and void spaces adjacent to cargo tanks and also deck areas throughout the entire length and breadth of the part of the ship over the above-mentioned spaces.

3.6.2 (1/1/2007)

For the definition of the cargo area of chemical tankers (see [3.9]) and gas carriers (see [3.18]), refer to Part E, Chapter 8 and Part E, Chapter 9, respectively.

3.7 Cargo ship

3.7.1 (1/1/2007)

Cargo ship is any ship which is not a passenger ship.

3.8 Cargo spaces

3.8.1 (1/1/2007)

Cargo spaces are spaces used for cargo, cargo oil tanks, tanks for other liquid cargo and trunks to such spaces.

3.9 Chemical tanker

3.9.1 (1/1/2007)

Chemical tanker is a tanker constructed or adapted and used for the carriage in bulk of any liquid product of a flammable nature listed in Pt E, Ch 8, Sec 17.

3.10 Closed ro-ro spaces

3.10.1 (1/1/2007)

Closed ro-ro spaces are those ro-ro spaces which are neither open ro-ro spaces nor weather decks.

3.11 Closed vehicle spaces

3.11.1 (1/1/2007)

Closed vehicle spaces are vehicle spaces which are neither open vehicle spaces nor weather decks.

3.12 Combination carriers

3.12.1 (1/1/2007)

A combination carrier is a cargo ship designed to carry both oil and solid cargoes in bulk.

3.13 Continuously manned central control stations

3.13.1 (1/1/2007)

A continuously manned central control station is a central control station which is continuously manned by a responsible member of the crew.

3.14 Control stations

3.14.1 (1/1/2007)

Control stations are those spaces in which the ship's radio or main navigating equipment or the emergency source of power is located or where the fire recording or fire control equipment is centralized.

3.15 Crude oil

3.15.1 (1/1/2007)

Crude oil is any oil occurring naturally in the earth whether or not treated to render it suitable for transportation and includes crude oil where certain distillate fractions may have been removed from, or added to.

3.16 Deadweight

3.16.1 (1/1/2007)

The deadweight is the difference in tonnes between the displacement of a ship in water of a specific gravity of 1,025 t/m³ at the load waterline corresponding to the assigned summer freeboard and the lightweight of the ship.

3.17 Flashpoint

3.17.1 (1/1/2007)

Flashpoint is the temperature in degrees Celsius (closed cup test) at which a product will give off enough flammable vapour to be ignited, as determined by an approved flashpoint apparatus.

3.18 Gas carrier

3.18.1 (1/1/2007)

A gas carrier is a cargo ship constructed or adapted and used for the carriage in bulk of any liquefied gas or other products of a flammable nature listed in Pt E, Ch 9, Sec 19.

3.19 Lightweight

3.19.1 (1/1/2007)

The lightweight is the displacement of a ship in tonnes without cargo, fuel, lubricating oil, ballast water, fresh water and feed water in tanks, consumable stores, and passengers and crew and their effects.

3.20 Machinery spaces

3.20.1 (1/1/2007)

Machinery spaces are machinery spaces of category A and other spaces containing propulsion machinery, boilers, fuel oil units, steam and internal combustion engines, generators and major electrical machinery, oil filling stations, refrigerating, stabilizing, ventilation and air conditioning machinery, and similar spaces, and trunks to such spaces.

3.21 Machinery spaces of category A

3.21.1 (1/1/2007)

Machinery spaces of category A are those spaces and trunks to such spaces which contain either:

- a) internal combustion machinery used for main propulsion,
- b) internal combustion machinery used for purposes other than main propulsion where such machinery has in the aggregate a total power output of not less than 375 kW, or
- c) any oil-fired boiler or oil fuel unit, or any oil-fired equipment other than boilers, such as inert gas generators, incinerators, etc.

3.22 Main vertical zones

3.22.1 (1/7/2012)

Main vertical zones are those sections into which the hull, superstructure and deckhouses are divided by "A" class divisions, the mean length and width of which on any deck does not in general exceed 40 m.

3.23 Oil fuel unit

3.23.1 (1/1/2007)

The oil fuel unit is the equipment used for the preparation of oil fuel for delivery to an oil fired boiler or equipment used for the preparation for delivery of heated oil to an internal combustion engine and includes any oil pressure pumps, filters and heaters dealing with oil at a pressure of more than 0,18 MPa.

3.23.2 (1/1/2007)

"Oil fuel unit" includes any equipment used for the preparation and delivery of oil fuel, whether or not heated, to boilers (including inert gas generators) and engines

(including gas turbines) at a pressure of more than 0,18 MPa.

Note 1: For the purpose of these Rules "oil fuel" has the same meaning of "fuel oil".

3.24 Open decks (open deck spaces)

3.24.1 (1/7/2023)

Open decks (open deck spaces) are those *open deck spaces and enclosed promenades clear of lifeboat and liferaft embarkation and lowering stations. To be considered in this category, enclosed promenades shall have no significant fire risk, meaning that furnishings shall be restricted to deck furniture. In addition, such spaces shall be naturally ventilated by permanent openings.*

Air spaces (the space outside superstructures and deckhouses).

3.25 Open ro-ro spaces

3.25.1 (1/1/2007)

Open ro-ro spaces are those ro-ro spaces that are either open at both ends or have an opening at one end and are provided with adequate natural ventilation effective over their entire length through permanent openings distributed in the side plating or deckhead or from above, having a total area of at least 10% of the total area of the space's sides.

3.26 Open vehicle spaces

3.26.1 (1/1/2007)

Open vehicle spaces are those vehicle spaces that are either open at both ends or have an opening at one end and are provided with adequate natural ventilation effective over their entire length through permanent openings distributed in the side plating or deckhead or from above, having a total area of at least 10% of the total area of the space's sides.

3.27 Passenger ship

3.27.1 (1/1/2007)

A passenger ship is a ship which carries more than twelve passengers.

3.28 Public spaces

3.28.1 (1/1/2007)

Public spaces are those portions of the accommodation which are used for halls, dining rooms, lounges and similar permanently enclosed spaces.

3.29 Ro-ro spaces

3.29.1 (1/1/2007)

Ro-ro spaces are spaces not normally subdivided in any way and extending to either a substantial length or the entire length of the ship in which motor vehicles with fuel in their tanks for their own propulsion and/or goods (packaged or in bulk, in or on rail or road cars, vehicles (including road or rail tankers), trailers, containers, pallets, demountable tanks or in or on similar stowage units or

other receptacles) can be loaded and unloaded normally in a horizontal direction.

3.30 Ro-ro passenger ship

3.30.1 (1/1/2007)

Ro-ro passenger ship means a passenger ship with ro-ro spaces or special category spaces as defined in [3.32].

3.31 Service spaces

3.31.1 (1/1/2007)

Service spaces are those spaces used for galleys, pantries containing cooking appliances, lockers, mail and specie rooms, storerooms, workshops other than those forming part of the machinery spaces, and similar spaces and trunks to such spaces.

3.32 Special category spaces

3.32.1 (1/1/2007)

Special category spaces are those enclosed vehicle spaces above and below the bulkhead deck, into and from which vehicles can be driven and to which passengers have access. Special category spaces may be accommodated on more than one deck provided that the total overall clear height for vehicles does not exceed 10 m.

3.33 Tanker

3.33.1 (1/1/2007)

A tanker is a cargo ship constructed or adapted for the carriage in bulk of liquid cargoes of an inflammable nature.

Note 1: For the purpose of this Chapter, the term tanker includes the following service notations (see Pt A, Ch 1, Sec 2, Tab 1):

- Chemical tanker
- Combination carrier/OBO
- Combination carrier/OOC
- Flammable liquid substances tanker
- Liquefied gas carrier
- Oil recovery ship
- Oil tanker.

3.34 Vehicle spaces

3.34.1 (1/1/2007)

Vehicle spaces are cargo spaces intended for the carriage of motor vehicles with fuel in their tanks for their own propulsion.

3.35 Weather decks

3.35.1 (1/1/2007)

A weather deck is a deck which is completely exposed to the weather from above and from at least two sides.

4 Type approved products

4.1

4.1.1 (1/1/2007)

The following materials, equipment, systems or products in general used for fire protection are to be type approved by

the Society, except for special cases for which acceptance may be given for individual ships on the basis of suitable documentation or ad hoc tests:

- a) Flexible pipes and expansion bellows of non-conventional material for any type of fluid
- b) Nozzles for fixed pressure water-spraying fire-extinguishing systems for machinery spaces and boiler rooms
- c) Sensing heads for automatic fire alarm and fire detection systems.
- d) Fixed fire detection and fire alarm systems
- e) Explosive mixture detecting systems
- f) Portable explosive mixture detecting apparatus
- g) Fixed instruments for measuring the oxygen content for inert gas systems serving cargo tanks
- h) Portable instruments for measuring the oxygen content for inert gas systems serving cargo tanks.

5 Probability of ignition

5.1 Arrangements for gaseous fuel for domestic purposes

5.1.1 (1/1/2007)

In general gaseous fuel systems may only be considered for cargo ships.

However, this does not preclude the use, on passenger ships, of movable cooking appliances - the so-called "flambé carts" - providing they meet the following requirements:

- a) Constructional requirements:
 - 1) In addition to the main gas supply valve, the flambé carts are equipped with an emergency gas shut-off valve which can be activated:
 - manually by the operator, either by pulling on a metallic wire loop or using a rod pull type lever;
 - automatically with a mechanical (in general gravity type) tip over device which will shut off the gas flow from the gas cylinder should the cart accidentally tip over.
 - 2) The regulation system ensures a pressure of about 0,0001 MPa downstream from the regulator itself.
 - 3) A pressure gauge is fitted between the gas cylinder and the regulation system, to indicate the gas pressure inside the cylinder.
 - 4) Special materials are used for the low pressure hose (between the regulation system and the stove) so that, in case of fire, the hose melts and closes on itself acting as an automatic check valve.
 - 5) The gas cylinder is safely secured on its cradle inside the cart.
 - 6) A safely re-ignition system is provided to automatically relight the burner if the flame goes out when the gas valve is "on".
 - 7) At least two of the four swivel castors are equipped with brakes, to block the cart in position.

- b) Operational requirements.

Flambé carts complying with the constructional requirements listed under item a) above may be used in public spaces (restaurant, buffet, etc.) on passenger ships under the following conditions, the implementation of which is the Owner's responsibility:

- 1) The carts are safely secured, specially when they are left unmanned in the space where they are used.
- 2) The number of carts permitted in a public space is such that the free volume at ambient temperature and atmospheric pressure of the natural gas contained in the cylinders of all the carts is less than 2% of the gross volume of the public space.
- 3) No spare full gas cylinders are permitted on board. Empty bottles are replaced only when the ship is in the harbour.

5.2 Cargo area of tankers

5.2.1 Restriction on boundary openings (1/7/2014)

Where driven shafts pass through pump room bulkhead or deck plating, gas-tight glands are to be fitted. The glands are to be efficiently lubricated from outside the pump room. The seal parts of the glands are to be of material that will not initiate sparks. The glands are to be constructed and fitted in accordance with the relevant Rules for fittings attached to watertight bulkheads and, if a bellows piece is incorporated in the design, it is to be pressure tested before fitting.

5.2.2 Ventilation systems in cargo pump rooms (1/1/2007)

Discharges and air inlets are to be located at a vertical distance of at least 2,4 m from the open deck. Air discharges are also to be arranged at a horizontal distance of not less than 3 m from any other opening leading to the served spaces.

The ventilation system capable of providing the required air changes per hour is to comply with the following as applicable:

- a) in order to avoid air stagnation zones, air exhaust ports inside the pump room are to be adequately distributed and the various landings are to consist of open gratings or perforated flats;
- b) inlet ducts are generally to end at the top of the room and outlet ducts are to extend below the floor plates, with suction ports at the level of the upper edge of ordinary floors or bottom longitudinals;
- c) in addition, suction ducts are to be provided with an emergency intake at approximately 2 m above the pump room lower grating, with a shutter capable of being opened or closed both at lower grating level and from the weather deck level, so that suction normally occurs through the lower suction ports and, in the event of the pump room flooding, through those at the top branched from the emergency intake;
- d) an arrangement involving a specific ratio of areas of upper emergency and lower main ventilator openings, which can be shown to result in at least the required 20

air changes per hour through the lower inlets, can be adopted without the use of shutters.

When the lower access inlets are closed then at least 15 air changes per hour are to be obtained through the upper inlets.

5.2.3 Ventilation systems in spaces other than the cargo pump room (1/1/2007)

Hose lockers and enclosed or partially enclosed spaces adjacent to cargo tanks are to be independently ventilated, in general by mechanical ventilation (exhaust) where such spaces are normally attended by the crew. In general, the arrangement of inlets and outlets serving these spaces is to comply with the provisions set out in [5.2.2] a).

5.2.4 Gas measurements (1/7/2021)

a) Portable instruments

Every oil tanker is to be provided with at least two portable gas detectors capable of measuring flammable vapour concentrations in air (%LEL) and at least two portable O₂ analysers. Alternatively, at least two gas detectors, each capable of measuring both oxygen and flammable vapour concentrations in air (%LEL), are to be provided.

In addition, for tankers fitted with inert gas systems, at least two portable gas detectors are to be capable of measuring concentrations of flammable vapours in inerted atmosphere (% gas by volume).

b) Arrangement for gas measurement in double hull and double bottom spaces.

Gas analysing units with non-explosion proof measuring equipment associated to the fixed gas sampling line system may be located in areas outside cargo areas, e.g. in the cargo control room, navigation bridge or engine room, when mounted on the forward bulkhead facing the cargo area provided the following requirements are observed:

- sampling lines are not to run through gas-safe spaces, except where permitted under the last bullet below;
- the gas sampling pipes are to be equipped with flame arresters. Sample gas is to be led to the atmosphere with outlets arranged in a safe location;
- bulkhead penetrations of sample pipes between safe and dangerous areas are to be approved by the Society and to have the same fire integrity as the division penetrated. A manual isolating valve is to be fitted in each of the sampling lines at the bulkhead on the gas-safe side;
- the gas detection equipment, including sample piping, sample pumps, solenoids, analysing units etc., is to be located in a reasonably gas-tight enclosure (e.g. a fully enclosed steel cabinet with a gasketed door), which is to be monitored by its own sampling point. At gas concentration above 30% of the lower flammable limit (LFL) inside the enclosure,

the entire gas analysing unit is to be automatically shut down;

and

- where the enclosure cannot be arranged directly on the bulkhead facing the cargo area, sample pipes are to be of steel or other equivalent material and without detachable connections, except for the connection points for isolating valves at the bulkhead and analysing units, and are to be routed along the shortest path.

5.2.5 Safety aspects of double hull spaces, double bottoms and duct keels under cargo oil tanks (1/1/2007)

Pipe ducts in the double bottom are to comply with the following requirements:

- a) In general, they are not to communicate with the engine room. When access is provided from a pump room, a watertight door is to be fitted complying with the requirements of Pt B, Ch 2, Sec 1, [6.2.1] and, in addition, with the following:
 - 1) in addition to operation from the bridge, the watertight door is to be capable of being manually closed from outside the main pump room entrance; and
 - 2) the watertight door is to be kept closed during normal operation of the ship except when access to the pipe tunnel is required.
- b) For double bottoms and ducts keels, provision is to be made for at least two exits to the open deck arranged as far apart from each other as practicable. One of these exits fitted with a watertight closure may lead to the cargo pump room;
- c) In the duct, provision is to be made for adequate mechanical ventilation.

5.3 Non-sparking fans

5.3.1 General (1/1/2007)

Where non-sparking fans are required by the Rules, the provisions of [5.3.2] and [5.3.3] are also to be complied with.

5.3.2 Design criteria (1/1/2007)

- a) The air gap between the impeller and the casing is to be not less than 0,1 of the shaft diameter in way of the impeller bearing and in any case not less than 2 mm, but need not exceed 13 mm.
- b) Protective screens with square mesh of not more than 13 mm are to be fitted to the inlet and outlet of ventilation openings on the open deck to prevent objects entering the fan housing.

5.3.3 Materials (1/1/2007)

- a) Except as indicated in the fourth bullet of item c) below, the impeller and the housing in way of the impeller are to be made of spark-proof materials which are

recognised as such by means of an appropriate test to the satisfaction of the Society.

- b) Electrostatic charges, both in the rotating body and the casing, are to be prevented by the use of antistatic materials. Furthermore, the installation on board of ventilation units is to be such as to ensure their safe bonding to the hull.
- c) Tests may not be required for fans having the following material combinations:
 - impellers and/or housings of non-metallic material, due regard being paid to the elimination of static electricity
 - impellers and housings of non-ferrous materials
 - impellers of aluminium alloys or magnesium alloys and a ferrous (including austenitic stainless steel) housing on which a ring of suitable thickness of non-ferrous material is fitted in way of the impeller
 - any combination of ferrous (including austenitic stainless steel) impellers and housings with not less than 13 mm design tip clearance.
- d) The following impeller and housing combinations are considered as sparking and therefore are not permitted:
 - impellers of an aluminium alloy or a magnesium alloy and a ferrous housing, regardless of tip clearance
 - housings made of an aluminium alloy or a magnesium alloy and a ferrous impeller, regardless of tip clearance
 - any combination of ferrous impeller and housing with less than 13 mm design tip clearance.
- e) Complete fans are to be tested in accordance either with the Society's requirements or national or international standards accepted by the Society.

6 Suppression of fire - detection and alarm

6.1 Protection of machinery spaces

6.1.1 Installation (1/1/2007)

Fire detecting systems to be fitted in unattended machinery spaces are also to comply with the following:

- a) the system is to be designed with self-monitoring properties. Power or system failures are to initiate an audible alarm distinguishable from the fire alarm.
- b) The fire detection indicating panel is to be located on the navigating bridge, fire control station, or other accessible place where a fire in the machinery space will not render it inoperative.
- c) The fire detection indicating panel is to indicate the place of the detected fire in accordance with the arranged fire zones by means of a visual signal. Audible signals clearly distinguishable in character from any other audible signals are to be audible throughout the navigating bridge and the accommodation area of the

personnel responsible for the operation of the machinery space.

- d) Fire detectors are to be of types, and so located, that they will rapidly detect the onset of fire in conditions normally present in the machinery space. Consideration is to be given to avoiding false alarms. The type and location of detectors are to be approved by the Society and a combination of detector types is recommended in order to enable the system to react to more than one type of fire symptom.
- e) Fire detector zones are to be arranged in a manner that will enable the operating staff to locate the seat of the fire. The arrangement and the number of loops and the location of detector heads are to be approved in each case. Air currents created by the machinery are not to render the detection system ineffective.
- f) When fire detectors are provided with the means to adjust their sensitivity, necessary arrangements are to be ensured to fix and identify the set point.
- g) When it is intended that a particular loop or detector is to be temporarily switched off, this state is to be clearly indicated. Reactivation of the loop or detector is to be performed automatically after a preset time.
- h) The fire detection indicating panel is to be provided with facilities for functional testing.
- i) The fire detecting system is to be fed automatically from the emergency source of power by a separate feeder if the main source of power fails.
- j) Facilities are to be provided in the fire detecting system to manually release the fire alarm from the following places:
 - passageways having entrances to the engine and boiler rooms,
 - the navigating bridge and control station in the engine room.
- k) The testing of the fire detecting system on board is to be carried out to the satisfaction of the Society.

For the fire detecting system for unattended machinery spaces, see also Pt F, Ch 3, Sec 2.

7 Suppression of fire: fire - fighting

7.1 Fire-extinguishing arrangements in machinery spaces

7.1.1 General (1/1/2007)

- a) Air pipes from oil fuel tanks are to be led to a safe position on the open deck. Air pipes from lubricating oil storage tanks may terminate in the machinery space, provided that the open ends are so situated that issuing oil cannot come into contact with electrical equipment or heated surfaces.

Any overflow pipe is to have a sectional area of at least 1.25 times that of the filling pipe and is to be led to an overflow tank of adequate capacity or to a storage tank having space reserved for overflow purposes.

An alarm device is to be provided to give warning when the oil reaches a predetermined level in the tank, or

alternatively, a sight glass is to be provided in the overflow pipe to indicate when any tank is overflowing. Such sight glasses are to be placed on vertical pipes only and in readily visible positions.

- b) Short sounding pipes may be used for tanks other than double bottom tanks without the additional closed level gauge provided an overflow system is fitted.
- c) Level switches may be used below the tank top provided they are contained in a steel enclosure or other enclosures not capable of being destroyed by fire.
- d) Controls required by this regulation are to be also provided from the compartment itself.
- e) Hose clamps and similar types of attachments for flexible pipes are permitted.
- f) Oil fuel in storage tanks is not to be heated to temperatures within 10°C below the flashpoint of the oil fuel, except that where oil fuel in service tanks, settling tanks and any other tanks in the supply system is heated the following arrangements are to be provided:
 - the length of the vent pipes from such tanks and/or a cooling device is sufficient for cooling the vapours to below 60°C, or the outlet of the vent pipes is located 3 m away from a source of ignition;
 - the vent pipes are fitted with flame screens;
 - there are no openings from the vapour space of the fuel tanks into machinery spaces (bolted manholes are acceptable);
 - enclosed spaces are not located directly over such fuel tanks, except for vented cofferdams;
 - electrical equipment is not fitted in the vapour space of the tanks, unless it is certified to be intrinsically safe.
- g) In the proximity of any electrical switchboard or section board having a power of 20 kW and upwards at least one CO₂ or powder extinguisher is to be fitted.

7.1.2 Fixed local application fire-fighting systems (1/7/2010)

This item applies to the installation of electrical and electronic equipment in engine rooms protected by fixed water-based local application fire-fighting systems (FWBLAFFS).

- a) The following definitions apply (see also Fig 1):
 - 1) Protected space: a machinery space where a FWBLAFFS is installed.
 - 2) Protected areas: areas within a protected space which are required to be protected by FWBLAFFS.
 - 3) Adjacent areas:
 - areas, other than protected areas, exposed to direct spray
 - areas, other than those defined above, where water may extend.
- b) The electrical and electronic equipment enclosures located within areas protected by FWBLAFFS and those within adjacent areas exposed to direct spray is to have a degree of protection not less than IP44, except where evidence of suitability is submitted to and approved by the Society.
- c) The electrical and electronic equipment within adjacent areas not exposed to direct spray may have a lower degree of protection provided evidence of suitability for use in these areas is submitted taking into account the design and equipment layout, e.g. position of inlet ventilation openings, and that cooling airflow for the equipment is assured.

Note 1: Additional precautions may be required to be taken in respect of:

- a) tracking as a result of water entering the equipment
- b) potential damage as a result of residual salts from sea water systems
- c) high voltage installations
- d) personnel protection against electric shock.

Figure 1 (1/7/2010)

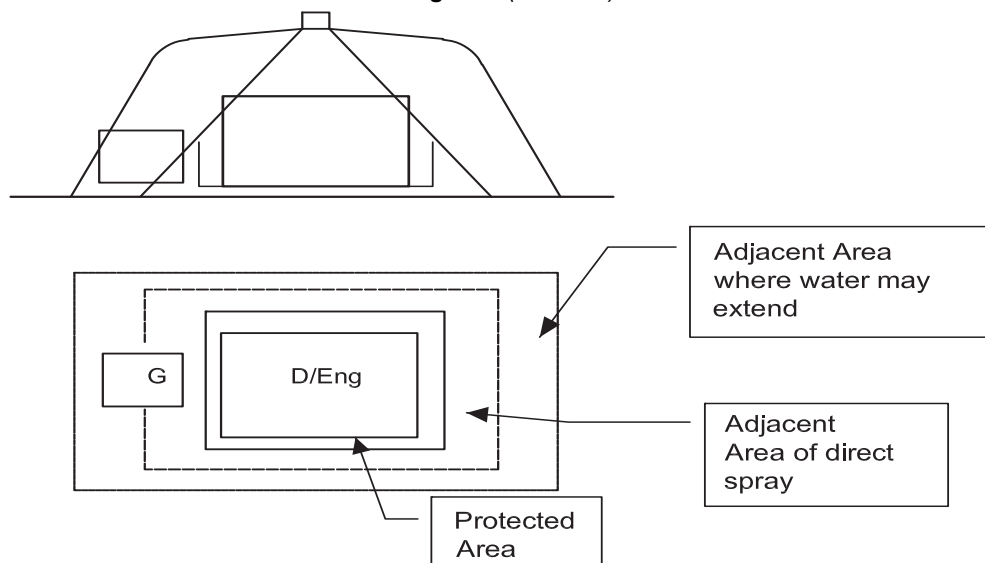

7.2 Low pressure CO₂ piping system

7.2.1 General (1/7/2022)

Where a low-pressure CO₂ system is fitted, the piping system is to be designed in such a way that the CO₂ pressure at the nozzles is not be less than 1 N/mm².

8 Fire safety systems: General requirements and application for inert gas systems

8.1 General requirements

8.1.1 (1/1/2007)

The inert gas system is to be capable of inerting, purging and gas-freeing empty cargo tanks and maintaining the atmosphere in cargo tanks with the required oxygen content.

8.1.2 (1/1/2007)

The inert gas system referred to in [8.2.1] is to be designed, constructed and tested in accordance with the requirements of [9]. Unless otherwise stated, for materials and design criteria of piping and relevant accessories reference is to be made to Ch 1, Sec 10.

8.1.3 (1/1/2007)

Tankers fitted with a fixed inert gas system are to be provided with a closed ullage system.

8.2 Application

8.2.1 (1/1/2016)

For tankers (including chemical carriers and gas carriers) of 8,000 tonnes deadweight and upwards, cargo tanks are to be protected by a fixed inert gas system in accordance with the requirements of [9], except that, for tankers of less than 20,000 tonnes deadweight in lieu of the fixed installations required in [9] the Society, after having given consideration to the ship's arrangement and equipment, may accept other equivalent arrangements or means of protection in accordance with [8.3].

8.2.2 (1/1/2007)

Tankers operating with a cargo tank cleaning procedure using crude oil washing are to be fitted with an inert gas system complying with the requirements of [9] and with fixed tank washing machines.

8.2.3 (1/1/2007)

Tankers required to be fitted with inert gas systems are to comply with the following provisions:

- double hull spaces are to be fitted with suitable connections for the supply of inert gas
- where hull spaces are connected to a permanently fitted inert gas distribution system, means are to be provided to prevent hydrocarbon gases from the cargo tanks entering the double hull space through the system and
- where such spaces are not permanently connected to an inert gas distribution system, appropriate means are to be provided to allow connection to the inert gas main.

8.2.4 (1/1/2007)

The requirements for inert gas systems given in [9] need not be applied to gas carriers:

- when carrying crude oil and petroleum products having a flashpoint not exceeding 60°C (closed cup test), provided that they comply with IMO Resolution A.567(14), or
- when carrying flammable cargoes other than crude oil or petroleum products such as cargoes listed in Chapter 17 and 18 of the International Code for the Construction and Equipment of Ships Carrying Dangerous Chemicals in Bulk, provided that the capacity of tanks used for their carriage does not exceed 3000 m³, the individual nozzle capacities of tank washing machines do not exceed 17,5 m³/h and the total combined throughput from the number of machines in use in a cargo tank at any one time does not exceed 110 m³/h.

8.3 Requirements for equivalent systems

8.3.1 (1/1/2007)

When an installation equivalent to a fixed inert gas system is installed, it is to:

- be capable of preventing dangerous accumulations of explosive mixtures in intact cargo tanks during normal service throughout the ballast voyage and necessary in-tank operations, and
- be so designed as to minimise the risk of ignition from the generation of static electricity by the system itself.

9 Inert gas systems

9.1 Contents

9.1.1 (1/1/2016)

This item [9] gives the specifications for inert gas systems in cargo oil tanks and double hull spaces in oil tankers, chemical tankers and gas carriers as required by this Chapter.

9.2 Engineering specifications

9.2.1 Definitions (1/1/2016)

For the purposes of this item [9], the following definitions apply:

- Cargo tanks means those cargo tanks, including slop tanks, which carry cargoes, or cargo residues, having a flashpoint not exceeding 60°C.
- Inert gas system includes inert gas systems using flue gas, inert gas generators, and nitrogen generators and means the inert gas plant and inert gas distribution together with means for preventing backflow of cargo gases to machinery spaces, fixed and portable measuring instruments and control devices.
- Gas-safe space is a space in which the entry of gases would produce hazards with regard to flammability or toxicity.
- Gas-free is a condition in a tank where the content of hydrocarbon or other flammable vapour is less than 1% of the lower flammable limit (LFL), the oxygen content is at least 21%, and no toxic gases are present.

9.3 Requirements for all systems

9.3.1 General (1/1/2016)

- a) The inert gas system referred to in chapter II-2 of the Convention is to be designed, constructed and tested to the satisfaction of the Society. It is to be designed to be capable of rendering and maintaining the atmosphere of the relevant cargo tanks non-flammable
- b) The system is to be capable of:
 - 1) inerting empty cargo tanks and maintaining the atmosphere in any part of the tank with an oxygen content not exceeding 8% by volume and at a positive pressure in port and at sea except when it is necessary for such a tank to be gas-free;
 - 2) eliminating the need for air to enter a tank during normal operations except when it is necessary for such a tank to be gas-free;
 - 3) purging empty cargo tanks of hydrocarbon or other flammable vapours, so that subsequent gas-freeing operations will at no time create a flammable atmosphere within the tank;
 - 4) delivering inert gas to the cargo tanks at a rate of at least 125% of the maximum rate of discharge capacity of the ship expressed as a volume.
For chemical tankers and chemical/product tankers, the Society may accept inert gas systems having a lower delivery capacity provided that the maximum rate of discharge of cargoes from cargo tanks being protected by the system is restricted to not more than 80% of the inert gas capacity; and
 - 5) delivering inert gas with an oxygen content of not more than 5% by volume to the cargo tanks at any required rate of flow.
- c) Materials used in inert gas systems are to be suitable for their intended purpose. In particular, those components which may be subjected to corrosive action of the gases and/or liquids are to be either constructed of corrosion-resistant material or lined with rubber, glass fibre epoxy resin or other equivalent coating material.
- d) The inert gas supply may be:
 - 1) treated flue gas from main or auxiliary boilers, or
 - 2) gas from an oil or gas-fired gas generator, or
 - 3) gas from nitrogen generators.

The Society may accept systems using inert gases from one or more separate gas generators or other sources or any combination thereof, provided that an equivalent level of safety is achieved. Such systems are, as far as practicable, to comply with the requirements of this chapter. Systems using stored carbon dioxide are not to be permitted unless the Society is satisfied that the risk of ignition from generation of static electricity by the system itself is minimized.

9.3.2 Safety measures (1/1/2016)

- a) The inert gas system is to be so designed that the maximum pressure which it can exert on any cargo tank will not exceed the test pressure of any cargo tank.
- b) Automatic shutdown of the inert gas system and its component parts are to be arranged on predetermined

limits being reached, taking into account the provisions of [9.3.4], [9.4.3] and [9.5.3].

- c) Suitable shutoff arrangements are to be provided on the discharge outlet of each generator plant.
- d) The system is to be designed to ensure that if the oxygen content exceeds 5% by volume, the inert gas is to be automatically vented to atmosphere.
- e) Arrangements are to be provided to enable the functioning of the inert gas plant to be stabilized before commencing cargo discharge. If blowers are to be used for gas-freeing, their air inlets are to be provided with blanking arrangements.
- f) Where a double block and bleed valve is installed, the system is to ensure upon loss of power that the block valves are automatically closed and the bleed valve is automatically open.

9.3.3 System components (1/1/2016)

- a) Non-return devices
 - 1) At least two non-return devices are to be fitted in order to prevent the return of vapour and liquid to the inert gas plant, or to any gas-safe spaces.
 - 2) The first non-return device is to be a deck seal of the wet, semi-wet, or dry type or a double-block and bleed arrangement. Two shut-off valves in series with a venting valve in between may be accepted provided:
 - the operation of the valve is automatically executed. Signal(s) for opening/closing is (are) to be taken from the process directly, e.g. inert gas flow or differential pressure; and
 - alarm for faulty operation of the valves is provided, e.g. the operation status of "blower stop" and "supply valve(s) open" is an alarm condition.
 - 3) The second non-return device is to be a non-return valve or equivalent capable of preventing the return of vapours and liquids and fitted between the deck water seal (or equivalent device) and the first connection from the inert gas main to a cargo tank. It is to be provided with positive means of closure. As an alternative to positive means of closure, an additional valve having such means of closure may be provided between the non-return valve and the first connection to the cargo tanks to isolate the deck water seal, or equivalent device, from the inert gas main to the cargo tanks.
 - 4) A water seal, if fitted, is to be capable of being supplied by two separate pumps, each of which is to be capable of maintaining an adequate supply at all times. The audible and visual alarm on the low level of water in the water seal are to operate at all times.
 - 5) The arrangement of the water seal, or equivalent devices, and its associated fittings are to be such that it will prevent backflow of vapours and liquids and

will ensure the proper functioning of the seal under operating conditions.

- 6) Provision is to be made to ensure that the water seal is protected against freezing, in such a way that the integrity of the seal is not impaired by overheating.
 - 7) A water loop or other approved arrangement is also to be fitted to each associated water supply and drain pipe and each venting or pressure-sensing pipe leading to gas-safe spaces. Means are to be provided to prevent such loops from being emptied by vacuum.
 - 8) Any water seal, or equivalent device, and loop arrangements are to be capable of preventing the return of vapours and liquids to an inert gas plant at a pressure equal to the test pressure of the cargo tanks.
 - 9) The non-return devices are to be located in the cargo area on deck.
- b) Inert gas lines
- 1) The inert gas main may be divided into two or more branches forward of the non-return devices required by [9.3.3] a).
 - 2) The inert gas main is to be fitted with branch piping leading to the cargo tank. Branch piping for inert gas is to be fitted with either stop valves or equivalent means of control for isolating each tank. Where stop valves are fitted, they are to be provided with locking arrangements. The control system is to provide unambiguous information of the operational status of such valves to at least the control panel required in [9.3.4].
 - 3) Each cargo tank not being inerted is to be capable of being separated from the inert gas main by:
 - removing spool-pieces, valves or other pipe sections, and blanking the pipe ends; or
 - arrangement of two spectacle flanges in series with provisions for detecting leakage into the pipe between the two spectacle flanges; or
 - equivalent arrangements to the satisfaction of the Society, providing at least the same level of protection.
 - 4) Means are to be provided to protect cargo tanks against the effect of overpressure or vacuum caused by thermal variations and/or cargo operations when the cargo tanks are isolated from the inert gas mains.
 - 5) Piping systems are to be so designed as to prevent the accumulation of cargo or water in the pipelines under all normal conditions.
 - 6) Arrangements are to be provided to enable the inert gas main to be connected to an external supply of inert gas. The arrangements are to consist of a 250 mm nominal pipe size bolted flange, isolated from the inert gas main by a valve and located forward of the non-return valve. The design of the flange should conform to the appropriate class in the standards

adopted for the design of other external connections in the ship's cargo piping system.

- 7) If a connection is fitted between the inert gas main and the cargo piping system, arrangements are to be made to ensure an effective isolation having regard to the large pressure difference which may exist between the systems. This is to consist of two shutoff valves with an arrangement to vent the space between the valves in a safe manner or an arrangement consisting of a spool-piece with associated blanks.
- 8) The valve separating the inert gas main from the cargo main and which is on the cargo main side is to be a non-return valve with a positive means of closure.
- 9) Inert gas piping systems are not to pass through accommodation, service and control station spaces.
- 10) In combination carriers, the arrangement to isolate the slop tanks containing oil or oil residues from other tanks is to consist of blank flanges which will remain in position at all times when cargoes other than oil are being carried except as provided for in the relevant section of the guidelines developed by IMO (see Note 1).

Note 1: Refer to the Revised Guidelines for inert gas systems (IMO MSC/Circ.353), as amended by IMO MSC/Circ.387.

9.3.4 Indicators and alarms (1/1/2016)

- a) The operation status of the inert gas system is to be indicated in a control panel.
- b) Instrumentation is to be fitted for continuously indicating and permanently recording, when inert gas is being supplied:
 - 1) the pressure of the inert gas mains forward of the non-return devices; and
 - 2) the oxygen content of the inert gas.
- c) The indicating and recording devices are to be placed in the cargo control room where provided. But where no cargo control room is provided, they are to be placed in a position easily accessible to the officer in charge of cargo operations.
- d) In addition, meters are to be fitted:
 - 1) on the navigating bridge to indicate at all times the pressure referred to in b) 1) and the pressure in the slop tanks of combination carriers, whenever those tanks are isolated from the inert gas main; and
 - 2) in the machinery control room or in the machinery space to indicate the oxygen content referred to in b) 2).
- e) Audible and visual alarms
 - 1) Audible and visual alarms are to be provided, based on the system designed, to indicate:
 - oxygen content in excess of 5% by volume;
 - failure of the power supply to the indicating devices as referred to in b);
 - gas pressure less than 100 mm water gauge. The alarm arrangement is to be such as to ensure that

the pressure in slop tanks in combination carriers can be monitored at all times;

- high-gas pressure; and
 - failure of the power supply to the automatic control system.
- 2) The alarms required in first, third and fifth bullet of the above item 1) are to be fitted in the machinery space and cargo control room, where provided, but in each case in such a position that they are immediately received by responsible members of the crew.
 - 3) An audible alarm system independent of that required in the third bullet of the above item 1) or automatic shutdown of cargo pumps are to be provided to operate on predetermined limits of low pressure in the inert gas main being reached.
 - 4) Two oxygen sensors are to be positioned at appropriate locations in the space or spaces containing the inert gas system. If the oxygen level falls below 19%, these sensors are to trigger alarms, which are to be both visible and audible inside and outside the space or spaces and are to be placed in such a position that they are immediately received by responsible members of the crew.

9.3.5 Instruction manuals (1/1/2016)

Detailed instruction manuals are to be provided on board, covering the operations, safety and maintenance requirements and occupational health hazards relevant to the inert gas system and its application to the cargo tank system (see Note 1). The manuals are to include guidance on procedures to be followed in the event of a fault or failure of the inert gas system.

Note 1: Refer to the Revised Guidelines for inert gas systems (IMO MSC/Circ.353), as amended by IMO MSC/Circ.387.

9.4 Requirements for flue gas and inert gas generator systems

9.4.1 Application (1/1/2016)

In addition to the provisions [9.3], for inert gas systems using flue gas or inert gas generators, the provisions of this item [9.4] are to be applied.

9.4.2 System requirements (1/1/2016)

a) Inert gas generators

- 1) two fuel oil pumps are to be fitted to the inert gas generator. Suitable fuel in sufficient quantity is to be provided for the inert gas generators.
- 2) the inert gas generators are to be located outside the cargo tank area. Spaces containing inert gas generators are to have no direct access to accommodation, service or control station spaces, but may be located in machinery spaces. If they are not located in machinery spaces, such a compartment is to be separated by a gastight steel bulkhead and/or deck from accommodation, service and control station spaces. Adequate positive-

pressure-type mechanical ventilation is to be provided for such a compartment.

b) Gas regulating valves

- 1) A gas regulating valve is to be fitted in the inert gas main. This valve is to be automatically controlled to close, as required in [9.3.2] b). It is also to be capable of automatically regulating the flow of inert gas to the cargo tanks unless means are provided to automatically control the inert gas flow rate.
- 2) The gas regulating valve is to be located at the forward bulkhead of the forward most gas-safe space through which the inert gas main passes.

c) Cooling and scrubbing arrangement

- 1) Means are to be fitted which will effectively cool the volume of gas specified in [9.3.1] b) and remove solids and sulphur combustion products. The cooling water arrangements are to be such that an adequate supply of water will always be available without interfering with any essential services on the ship. Provision is also to be made for an alternative supply of cooling water.
- 2) Filters or equivalent devices are to be fitted to minimize the amount of water carried over to the inert gas blowers.

d) Blowers

- 1) At least two inert gas blowers are to be fitted and be capable of delivering to the cargo tanks at least the volume of gas required by [9.3.1] b). For systems fitted with inert gas generators, the Society may permit only one blower if that system is capable of delivering the total volume of gas required by [9.3.1] b) to the cargo tanks, provided that sufficient spares for the blower and its prime mover are carried on board to enable any failure of the blower and its prime mover to be rectified by the ship's crew.
- 2) Where inert gas generators are served by positive displacement blowers, a pressure relief device is to be provided to prevent excess pressure being developed on the discharge side of the blower.
- 3) When two blowers are provided, the total required capacity of the inert gas system is to be divided evenly between the two and in no case is one blower to have a capacity less than 1/3 of the total required.

e) Inert gas isolating valves

For systems using flue gas, flue gas isolating valves are to be fitted in the inert gas mains between the boiler uptakes and the flue gas scrubber. These valves are to be provided with indicators to show whether they are open or shut, and precautions are to be taken to maintain them gastight and keep the seatings clear of soot. Arrangements are to be made to ensure that boiler soot blowers cannot be operated when the corresponding flue gas valve is open.

f) Prevention of flue gas leakage

- 1) Special consideration is to be given to the design and location of scrubber and blowers with relevant

pipings and fittings in order to prevent flue gas leakages into enclosed spaces.

- 2) To permit safe maintenance, an additional water seal or other effective means of preventing flue gas leakage is to be fitted between the flue gas isolating valves and scrubber or incorporated in the gas entry to the scrubber.

9.4.3 Indicators and alarms (1/1/2016)

- a) In addition to the requirements in [9.3.4] b), means are to be provided for continuously indicating the temperature of the inert gas at the discharge side of the system, whenever it is operating.
- b) In addition to the requirements of [9.3.4] e), audible and visual alarms are to be provided to indicate:
 - 1) insufficient fuel oil supply to the oil-fired inert gas generator;
 - 2) failure of the power supply to the generator;
 - 3) low water pressure or low water flow rate to the cooling and scrubbing arrangement;
 - 4) high water level in the cooling and scrubbing arrangement;
 - 5) high gas temperature;
 - 6) failure of the inert gas blowers; and
 - 7) low water level in the water seal.

9.5 Requirements for nitrogen generator systems

9.5.1 Application (1/1/2016)

In addition to the provisions in [9.3], for inert gas systems using nitrogen generators, the provisions of this item [9.5] are to be applied.

9.5.2 System requirements (1/1/2016)

- a) The inert gas is to be high purity nitrogen produced by separating air into its component gases by passing compressed air through a bundle of hollow fibres, semi-permeable membranes or absorber material.
- b) The system is to consist of a feed air treatment system and any number of membrane or absorber modules in parallel necessary to meet the requirements in [9.3.1] d).
- c) The system is to be provided with one or more compressors to generate enough positive pressure to be capable of delivering the total volume of gas required by [9.3.1] b).
- d) Where two compressors are provided, the total required capacity of the system is preferably to be divided equally between the two compressors, and in no case is one compressor to have a capacity less than 1/3 of the total capacity required.
- e) A feed air treatment system is to be fitted to remove free water, particles and traces of oil from the compressed air, while preserving the gas temperature according to specification.

- f) The oxygen-enriched air from the nitrogen generator and the nitrogen-product enriched gas from the protective devices of the nitrogen receiver are to be discharged to a safe location (see Note 1) on the open deck.

Note 1: "safe location" needs to address the two types of discharges separately:

- oxygen-enriched air from the nitrogen generator - safe locations on the open deck are:
 - outside of hazardous area;
 - not within 3m of areas traversed by personnel; and
 - not within 6m of air intakes for machinery (engines and boilers) and all ventilation inlets.
 - nitrogen-product enriched gas from the protective devices of the nitrogen receiver - safe locations on the open deck are:
 - not within 3m of areas traversed by personnel; and
 - not within 6m of air intakes for machinery (engines and boilers) and all ventilation inlets/outlets
- g) The air compressor and nitrogen generator may be installed in the engine-room or in a separate compartment. A separate compartment and any installed equipment is to be treated as an "Other machinery space" with respect to fire protection. Where a separate compartment is provided for the nitrogen generator, the compartment is to be fitted with an independent mechanical extraction ventilation system providing six air changes per hour. The compartment is to have no direct access to accommodation spaces, service spaces and control stations.
 - h) Where a nitrogen receiver or a buffer tank is installed, it may be installed in a dedicated compartment, in a separate compartment containing the air compressor and the generator, in the engine room, or in the cargo area. Where the nitrogen receiver or a buffer tank is installed in an enclosed space, the access is to be arranged only from the open deck and the access door is to be opened outwards. Adequate, independent mechanical ventilation, of the extraction type, is to be provided for such a compartment.
 - i) In order to permit maintenance, means of isolation are to be fitted between the generator and the receiver.
 - j) The system is to be fitted with automatic means to discharge "off-spec" gas to the atmosphere during start-up and abnormal operation.

9.5.3 Indicators and alarms (1/1/2016)

- a) In addition to the requirements in [9.3.4] b), instrumentation is to be provided for continuously indicating the temperature and pressure of air at the suction side of the nitrogen generator.
- b) In addition to the requirements in [9.3.4] e), audible and visual alarms are to be provided to include:
 - 1) failure of the electric heater, if fitted;
 - 2) low feed-air pressure or flow from the compressor;
 - 3) high-air temperature; and
 - 4) high condensate level at automatic drain of water separator.

9.6 Nitrogen /Inert Gas Systems Fitted for Purposes other than Inerting Required by SOLAS Reg. II-2/4.5.5.1 and 4.5.5.2

9.6.1 Application (1/1/2016)

This item [9.6] applies to systems fitted on oil tankers, gas tankers or chemical tankers to which SOLAS regulations II-2/4.5.5.1 and 4.5.5.2 do not apply.

9.6.2 Applicable requirements (1/1/2016)

Items [9.3.2] b), [9.3.2] d), [9.3.4] b), [9.3.4] c), first and second bullet of [9.3.4] e)1), [9.3.4] e)4), [9.5.2] c), [9.5.2] e), [9.5.2] g), [9.5.2] h), [9.5.3]a) and b), as applicable, apply to the systems.

The requirements in [9.5.2] a), e), f) and j)) apply.

9.6.3 Installation and tests (1/1/2016)

All the equipment is to be installed on board and tested under working conditions to the satisfaction of the Surveyor.

9.6.4 Non-return devices (1/1/2016)

The two non-return devices as required by [9.3.3] a)1) are to be fitted in the inert gas main. The non-return devices are to comply with [9.3.3] a)2) and [9.3.3] a)3); however, where the connections to the cargo tanks, to the hold spaces or to cargo piping are not permanent, the non-return devices required by [9.3.3] a)1) may be substituted by two non-return valves.

10 Installation of BWMS on-board ships

10.1 General

10.1.1 Application (1/7/2022)

This Article details fire safety measures, in addition to that required by SOLAS II-2, related to the installation of Ballast Water Management Systems onboard any ship.

The applicable requirements in Ch 1, Sec 10 and in Ch 1, App 8 are to be complied with.

The requirements in this Article apply for BWMS technologies as listed in Ch 1, App 8, Tab 1. BWMS with alternative technologies will be considered by the Society on case by case basis.

10.2 Fire categorization

10.2.1 General (1/7/2022)

BWMS is to be classified as follows for the purpose of applying the requirements of SOLAS Chapter II-2:

- BWMS containing oil-fired inert gas generators (i.e. BWMS cat.3b and 3c as per Ch 1, App 8, Tab 1) is to be treated as machinery spaces of category A
- Other BWMS are to be considered as other machinery spaces and are to be categorized, depending on the ship type (10) or (11) according to SOLAS II-2/9.2.2.3 or (7) according to SOLAS II-2/9.2.2.4, II-2/9.2.3 and II-2/9.2.4.

10.2.2 BWMS located in the cargo area of tankers (1/7/2022)

Notwithstanding the above, where a BWMS is located in the cargo area of a tanker as allowed by Ch 1, App 8, [3.2.1], b), the BWMS is to be categorized as (8), a cargo pump-room, according to SOLAS II-2/9.2.4.2.2 for determining the extent of fire protection to be provided.

Note 1: The cargo area of a tanker is defined in Ch 1, App 8, [2.1.2].

10.2.3 Storage of chemicals (1/7/2022)

a) Spaces where the storage of liquid or solid chemicals for BWMS is intended are to be categorized as store-rooms for the purpose of applying the requirements of SOLAS Chapter II-2, i.e.:

- On passenger ships carrying more than 36 passengers:
 - "Other spaces in which flammable liquids are stowed" as defined in SOLAS II-2/9.2.2.3.2.2(14), if flammable products are stored
 - "Store-rooms, workshops, pantries, etc." as defined in SOLAS II-2/9.2.2.3.2.2(13) otherwise.
- On other ships:
 - "Cargo pump-rooms" as defined in SOLAS II-2/9.2.4.2.2.2(8) if located in the cargo area of a tanker
 - "Service spaces (low risk)" as defined in SOLAS II-2/9.2.2.4.2.2(5), SOLAS II-2/9.2.3.3.2.2(5) or II-2/9.2.4.2.2.2(5) if the surface area is less than 4m² and if no flammable products are stored
 - "Service spaces (high risk)" as defined in SOLAS II-2/9.2.2.4.2.2(9), SOLAS II-2/9.2.3.3.2.2(9) or II-2/9.2.4.2.2.2(9) otherwise.

Note 1: It is understood that only chemical injection (cat.6 as per Ch 1, App 8, Tab 1), in-line flocculation (cat.2 as per Ch 1, App 8, Tab 1) and technologies using neutralizer injection (cat.4, 5, 6 and 7 as per Ch 1, App 8, Tab 1) will require chemical or additive storage.

- b) Where the storage of chemicals is foreseen in the same room as the ballast water management machinery, this room is to be considered both as a store-room and as a machinery space in line with [10.2.1].
- c) When the chemical substances are stored inside integral tanks, the ship's shell plating is not to form any boundary of the tank.
- d) Tanks containing chemicals are to be segregated from accommodation, service spaces, control stations, machinery spaces not related to the BWMS and from drinking water and stores for human consumption by means of a cofferdam, void space, cargo pump-room, empty tank, oil fuel storage tank, BWMS or other similar space. On-deck stowage of permanently attached deck tanks or installation of independent tanks in otherwise empty hold spaces should be considered as satisfying this provision.

10.3 BWMR location and boundaries

10.3.1 BWMS using chemical substances (1/7/2022)

For BWMS storing, introducing or generating chemicals, the BWMR and chemical substance storage rooms are not to be located in the accommodation area. Any ventilation exhaust or other openings from these rooms are to be located not less than 3m from entrances, air inlets and openings to accommodation spaces.

This requirement need not apply in case the BWMS is located in the engine room.

10.3.2 Ozone-based BWMS (1/7/2022)

- a) Ozone-based BWMS – i.e. cat.7a and 7b - are to be located in dedicated compartment, separated from any other space by gastight boundaries. Access to the BWMR from any other enclosed space is to be through airlock only, except if the only access to that space is from the open deck.

Access to the ozone based BWMR may be provided through the engine room only provided:

- Access from the engine room to the BWMR is through airlock and,
- An alarm repeater is provided in the BWMR, which will repeat any alarm activated in the engine room.

- b) A sign is to be affixed on the door providing personnel with a warning that ozone may be present and with the necessary instructions to be followed before entering the room.

10.3.3 General (1/7/2022)

BWMR containing equipment for BWMS of the following types is to be equipped with tested gastight and self-closing doors without any holding back arrangements:

- BWMS storing, introducing or generating chemical substances
- De-oxygenation based on inert gas generator
- Electrolysis
- Ozone injection.

Doors leading to the open deck need however not to be self-closing.

10.4 Fire fighting

10.4.1 Fixed fire-extinguishing system (1/7/2022)

- a) Where fitted, fixed fire extinguishing systems are to comply with the relevant provisions of the Fire Safety Systems Code.

- b) Ozone-based BWMS

BWMR containing equipment related to ozone-based BWMS is to be provided with a fixed fire extinguishing system suitable for category A machinery spaces and capable of manual release.

- c) Where a fixed fire-extinguishing system is provided in the BWMR, it should be compatible with the BWMS

and the chemical products that are used, produced or stored in the BWMR. Specific attention is to be paid to potential chemical reactions between the fire extinguishing medium and chemical products used for water treatment. Especially, water-based fire-extinguishing systems should be avoided in case of sulfuric acid storage.

- d) Foam fixed fire-extinguishing system.

For all kinds of BWMS, in case a foam fire extinguishing system is installed in the BWMR, its efficiency is not to be impaired by chemicals used by the BWMS where relevant.

- e) Where a fixed fire-extinguishing system is installed in the BWMR, automatic shutdown of the BWMS upon release of the fixed fire extinguishing system is to be arranged. Any need for cooldown necessary for safe shutdown to be considered in the shutdown sequence.

- f) Where BWMS that includes air or O₂ storage is located in a room covered by a fixed gas fire-extinguishing system, air or O₂ storage is to be taken into account for the gas capacity calculation, unless the discharge pipe from safety valves for air or O₂ storage are led directly to outside the room.

10.4.2 Portable fire-fighting equipment (1/7/2022)

There is to be at least one portable fire extinguisher that complies with the provisions of the Fire Safety Systems Code and suitable for electrical fires in the BWMR containing UV-type BWMS.

10.5 Fire prevention

10.5.1 Equipment protection (1/7/2022)

- a) Overcurrent or overvoltage protection is to be installed to protect UV type BWMS.
- b) Electrolysis reactors are to be provided with at least with two independent means of monitoring operation. The monitoring system is to initiate audible and visual alarms and automatic shutdown of the BWMS in the event that an anomaly is detected. Requirements for shutdown arrangement are clarified in Ch 1, App 8, [3.1.9].

Note 1: If a pressure relief valve is also provided, the vent of this valve is to be led to a safe location on the open deck, as clarified in Ch 1, App 8, [3.1.5]. The valve should be positioned to optimally remove gas from the electrolysis reactor.

10.5.2 Fire detection (1/7/2022)

- a) A fixed fire detection and fire alarm system complying with the provisions of the Fire Safety Systems Code is to be installed in spaces containing an inert gas generator or an ozone generator.
- b) A section of fire detectors which covers a control station, a service space or an accommodation space is not to include a BWMR containing equipment related to ozone based BWMS.

10.6 Ventilation

10.6.1 Ventilation arrangement (1/7/2022)

- a) The ventilation systems for BWMR containing BWMS of the following types are to be independent of the ventilation systems serving any other spaces:
 - BWMS storing, introducing or generating chemical substances
 - De-oxygenation, including pasteurization and de-oxygenation (cat.3 and cat.8 as per Ch 1, App 8, Tab 1)
 - Electrolysis
 - Ozone injection.
- b) The ventilation exhaust for BWMR containing a nitrogen generator is to be located in the lower part of the room in order to efficiently evacuate dangerous gases – as defined in Ch 1, App 8, [2.1.3] - heavier than air.
- c) The ventilation exhaust for BWMR containing electrolysis systems is to be located so as to be able to efficiently evacuate dangerous gases – as defined in Ch 1, App 8, [2.1.3] - that could be generated during the electrolysis process. Due regard is to be paid to the expected quantity and density of such gases when designing the ventilation exhaust.
- d) The following requirements apply to ventilation ducts serving BWMR for ozone-based BWMS:
 - The part of the ducts located outside of the BWMR is to be made of steel having a thickness of at least 3 mm for ducts with a free cross-sectional area of less than 0,075 m², at least 4 mm for ducts with a free cross-sectional area of between 0,075 m² and 0,45 m², and at least 5 mm for ducts with a free cross-sectional area of over 0,45 m². and
 - The ducts are to be suitably supported and stiffened
 - The outside openings of the ducts are to be fitted with protective screens of not more than 13 mm square mesh.
- e) The ventilation system for BWMR containing ozone-based BWMS or ventilation system for hydrogen de gas arrangement as required by Ch 1, App 8, [3.3.1] e) is to be interlocked with the BWMS such that:
 - In case of loss of ventilation (primary and secondary), a visual and audible alarm is to be triggered both inside and outside the BWMR and at a place where a responsible member of the crew is on duty. If the ventilation is not restored after a pre-set time, the BWMS is then to be automatically shut down. Any need for cooldown necessary for safe shutdown is to be considered in the shutdown sequence
 - It is not to be possible to start the BWMS without the ventilation running.

For ventilation systems serving BWMR and containing or conveying a dangerous gas, relevant requirements in Ch 1, App 8, [3.2] are to be satisfied.

10.6.2 Ventilation rate (1/7/2022)

- a) An adequate power ventilation system is to be provided in enclosed BWMR.
- b) The ventilation capacity is to be at least 30 air changes per hour where explosive or toxic gases may be generated during operation of the BWMS. The IMO reports issued during the basic and final approval procedures of the BWMS that make use of active substances (G9 Guidelines) and "safety hazard" as listed in Ch.17 of IBC code are to be used as references for identifying those cases.
- c) The ventilation capacity may be reduced as follows:
 - Flocculation-type BWMS: 6 air changes per hour
 - De-oxygenation, incl. pasteurization and de-oxygenation (cat.3 and cat.8 as per Ch 1, App 8, Tab 1): 6 air changes per hour
 - Full flow electrolysis: 6 air changes per hour
 - Side-stream electrolysis: 20 air changes per hour
 - Ozone injection: 20 air changes per hour
 - Chemical injection: 6 air changes per hour.

Note 1: More stringent ventilation capacity requirements may arise from other regulations e.g. IBC Code requirements for spaces located in the cargo area.

10.7 Personal equipment

10.7.1 General (1/7/2022)

- a) Suitable protection equipment are to be available onboard for the protection of the crew members who are engaged in the servicing, maintenance and repair of BWMS storing, introducing or generating chemicals, as recommended by the product manufacturers. The protection equipment is to consist of large aprons, special gloves with long sleeves, suitable footwear, coveralls of chemical-resistant materials, and tight fitting goggles or face shields or both. The protective clothing and equipment is to cover all skin so that no part of the body is unprotected. This protection equipment is to be provided separately without taking into account equipment required by other mandatory requirements.
- b) Work clothes and protective equipment are to be kept in easily accessible places and in special lockers. Such equipment is not to be kept within accommodation spaces, with the exception of new, unused equipment and equipment which has not been used since undergoing a thorough cleaning process. Notwithstanding the above, storage rooms for such equipment within accommodation spaces if adequately segregated from living spaces such as cabins, passageways, dining rooms, bathrooms, etc.
- c) When a BWMS storing, introducing or generating chemicals is installed on board, suitably marked decontamination showers and an eyewash are to be available in a convenient location in close proximity to the BWMS and the chemical store room(s).
- d) An emergency escape breathing apparatus (EEBD) is to be provided in the BWMR. This emergency escape breathing apparatus may be one of the EEBDs provided in accordance with the requirements of SOLAS II-2/13.

An EEBD need not be required for BWMS of cat.1 as per Ch 1, App 8, Tab 1.

- e) A personal ozone detector, calibrated as per the manufacturer's specifications, is to be provided for each person engaged in the servicing, maintenance and repair of BWMS utilizing ozone.
- f) A two-way portable radiotelephone apparatus dedicated for the BWMS service, maintenance and repair is to be provided, in addition to those required by SOLAS for fire-fighting purposes. This two-way radiotelephone apparatus is to be properly identified in order to avoid

mix-up with the apparatus intended for fire-fighting operations. Where the BWMS may release explosive gases, this two-way radiotelephone apparatus is to be of a certified safe type suitable for use in zone 1 hazardous areas, as defined in IEC Publication 60079. Where the BWMS stores, utilizes or introduces chemicals, the apparatus is to undergo deep cleaning or decontamination after use. A two-way portable radiotelephone apparatus need not be required for BWMS of cat.1 as per Ch 1, App 8, Tab 1.