

Rules for the Classification of Yachts Designed for Commercial Use

Effective from 1 January 2023

Part D

Materials and Welding

GENERAL CONDITIONS

Definitions:

“Administration” means the Government of the State whose flag the Ship is entitled to fly or under whose authority the Ship is authorised to operate in the specific case.

“IACS” means the International Association of Classification Societies.

“Interested Party” means the party, other than the Society, having an interest in or responsibility for the Ship, product, plant or system subject to classification or certification (such as the owner of the Ship and his representatives, the ship builder, the engine builder or the supplier of parts to be tested) who requests the Services or on whose behalf the Services are requested.

“Owner” means the registered owner, the ship owner, the manager or any other party with the responsibility, legally or contractually, to keep the ship seaworthy or in service, having particular regard to the provisions relating to the maintenance of class laid down in Part A, Chapter 2 of the Rules for the Classification of Ships or in the corresponding rules indicated in the specific Rules.

“Rules” in these General Conditions means the documents below issued by the Society:

- (i) Rules for the Classification of Ships or other special units;
- (ii) Complementary Rules containing the requirements for product, plant, system and other certification or containing the requirements for the assignment of additional class notations;
- (iii) Rules for the application of statutory rules, containing the rules to perform the duties delegated by Administrations;
- (iv) Guides to carry out particular activities connected with Services;
- (v) Any other technical document, as for example rule variations or interpretations.

“Services” means the activities described in Article 1 below, rendered by the Society upon request made by or on behalf of the Interested Party.

“Ship” means ships, boats, craft and other special units, as for example offshore structures, floating units and underwater craft.

“Society” or “TASNEEF” means Tasneef and/or all the companies in the Tasneef Group which provide the Services.

“Surveyor” means technical staff acting on behalf of the Society in performing the Services.

Article 1

1.1. The purpose of the Society is, among others, the classification and certification of ships and the certification of their parts and components. In particular, the Society:

- (i) sets forth and develops Rules;
- (ii) publishes the Register of Ships;
- (iii) issues certificates, statements and reports based on its survey activities.

1.2. The Society also takes part in the implementation of national and international rules and standards as delegated by various Governments.

1.3. The Society carries out technical assistance activities on request and provides special services outside the scope of classification, which are regulated by these general conditions, unless expressly excluded in the particular contract.

Article 2

2.1. The Rules developed by the Society reflect the level of its technical knowledge at the time they are published. Therefore, the Society, although committed also through its research and development services to continuous updating of the Rules, does not guarantee the Rules meet state-of-the-art science and technology at the time of publication or that they meet the Society's or others' subsequent technical developments.

2.2. The Interested Party is required to know the Rules on the basis of which the Services are provided. With particular reference to Classification Services, special attention is to be given to the Rules concerning class suspension, withdrawal and reinstatement. In case of doubt or inaccuracy, the Interested Party is to promptly contact the Society for clarification.

The Rules for Classification of Ships are published on the Society's website: www.tasneef.ae.

2.3. The Society exercises due care and skill:

- (i) in the selection of its Surveyors
- (ii) in the performance of its Services, taking into account the level of its technical knowledge at the time the Services are performed.

2.4. Surveys conducted by the Society include, but are not limited to, visual inspection and non-destructive testing. Unless otherwise required, surveys are conducted through sampling techniques and do not consist of comprehensive verification or monitoring of the Ship or of the items subject to certification. The surveys and checks made by the Society on board ship do not necessarily require the constant and continuous presence of the Surveyor. The Society may also commission laboratory testing, underwater inspection and other checks carried out by and under the responsibility of qualified service suppliers. Survey practices and procedures are selected by the Society based on its experience and knowledge and according to generally accepted technical standards in the sector.

Article 3

3.1. The class assigned to a Ship, like the reports, statements, certificates or any other document or information issued by the Society, reflects the opinion of the Society concerning compliance, at the time the Service is provided, of the Ship or product subject to certification, with the applicable Rules (given the intended use and within the relevant time frame).

The Society is under no obligation to make statements or provide information about elements or facts which are not part of the specific scope of the Service requested by the Interested Party or on its behalf.

3.2. No report, statement, notation on a plan, review, Certificate of Classification, document or information issued or given as part of the Services provided by the Society shall have any legal effect or implication other than a representation that, on the basis of the checks made by the Society, the Ship, structure, materials, equipment, machinery or any other item covered by such document or information meet the Rules. Any such document is issued solely for the use of the Society, its committees and clients or other duly authorised bodies and for no other purpose. Therefore, the Society cannot be held liable for any act made or document issued by other parties on the basis of the statements or information given by the Society. The validity, application, meaning and interpretation of a Certificate of Classification, or any other document or information issued by the Society in connection with its Services, is governed by the Rules of the Society, which is the sole subject entitled to make such interpretation. Any disagreement on technical matters between the Interested Party and the Surveyor in the carrying out of his functions shall be raised in writing as soon as possible with the Society, which will settle any divergence of opinion or dispute.

3.3. The classification of a Ship, or the issuance of a certificate or other document connected with classification or certification and in general with the performance of Services by the Society shall have the validity conferred upon it by the Rules of the Society at the time of the assignment of class or issuance of the certificate; in no case shall it amount to a statement or warranty of seaworthiness,

structural integrity, quality or fitness for a particular purpose or service of any Ship, structure, material, equipment or machinery inspected or tested by the Society.

3.4. Any document issued by the Society in relation to its activities reflects the condition of the Ship or the subject of certification or other activity at the time of the check.

3.5. The Rules, surveys and activities performed by the Society, reports, certificates and other documents issued by the Society are in no way intended to replace the duties and responsibilities of other parties such as Governments, designers, ship builders, manufacturers, repairers, suppliers, contractors or sub-contractors, Owners, operators, charterers, underwriters, sellers or intended buyers of a Ship or other product or system surveyed.

These documents and activities do not relieve such parties from any fulfilment, warranty, responsibility, duty or obligation (also of a contractual nature) expressed or implied or in any case incumbent on them, nor do they confer on such parties any right, claim or cause of action against the Society. With particular regard to the duties of the ship Owner, the Services undertaken by the Society do not relieve the Owner of his duty to ensure proper maintenance of the Ship and ensure seaworthiness at all times. Likewise, the Rules, surveys performed, reports, certificates and other documents issued by the Society are intended neither to guarantee the buyers of the Ship, its components or any other surveyed or certified item, nor to relieve the seller of the duties arising out of the law or the contract, regarding the quality, commercial value or characteristics of the item which is the subject of transaction.

In no case, therefore, shall the Society assume the obligations incumbent upon the above-mentioned parties, even when it is consulted in connection with matters not covered by its Rules or other documents.

In consideration of the above, the Interested Party undertakes to relieve and hold harmless the Society from any third party claim, as well as from any liability in relation to the latter concerning the Services rendered.

Insofar as they are not expressly provided for in these General Conditions, the duties and responsibilities of the Owner and Interested Parties with respect to the services rendered by the Society are described in the Rules applicable to the specific Service rendered.

Article 4

4.1. Any request for the Society's Services shall be submitted in writing and signed by or on behalf of the Interested Party. Such a request will be considered irrevocable as soon as received by the Society and shall entail acceptance by the applicant of all relevant requirements of the Rules, including these General Conditions. Upon acceptance of the written request by the Society, a contract between the Society and the Interested Party is entered into, which is regulated by the present General Conditions.

4.2. In consideration of the Services rendered by the Society, the Interested Party and the person requesting the service shall be jointly liable for the payment of the relevant fees, even if the service is not concluded for any cause not pertaining to the Society. In the latter case, the Society shall not be held liable for non-fulfilment or partial fulfilment of the Services requested. In the event of late payment, interest at the legal current rate increased by 1.5% may be demanded.

4.3. The contract for the classification of a Ship or for other Services may be terminated and any certificates revoked at the request of one of the parties, subject to at least 30 days' notice to be given in writing. Failure to pay, even in part, the fees due for Services carried out by the Society will entitle the Society to immediately terminate the contract and suspend the Services.

For every termination of the contract, the fees for the activities performed until the time of the termination shall be owed to the Society as well as the expenses incurred in view of activities already programmed; this is without prejudice to the right to compensation due to the Society as a consequence of the termination.

With particular reference to Ship classification and certification, unless decided otherwise by the Society, termination of the contract implies that the assignment of class to a Ship is withheld or, if already assigned, that it is suspended or withdrawn; any statutory certificates issued by the Society will be withdrawn in those cases where provided for by agreements between the Society and the flag State.

Article 5

5.1. In providing the Services, as well as other correlated information or advice, the Society, its Surveyors, servants or agents operate with due diligence for the proper execution of the activity. However, considering the nature of the activities performed (see art. 2.4), it is not possible to guarantee absolute accuracy, correctness and completeness of any information or advice supplied. Express and implied warranties are specifically disclaimed.

Therefore, except as provided for in paragraph 5.2 below, and also in the case of activities carried out by delegation of Governments, neither the Society nor any of its Surveyors will be liable for any loss, damage or expense of whatever nature sustained by any person, in tort or in contract, derived from carrying out the Services.

5.2. Notwithstanding the provisions in paragraph 5.1 above, should any user of the Society's Services prove that he has suffered a loss or damage due to any negligent act or omission of the Society, its Surveyors, servants or agents, then the Society will pay compensation to such person for his proved loss, up to, but not exceeding, five times the amount of the fees charged for the specific services, information or opinions from which the loss or damage derives or, if no fee has been charged, a maximum of AED5,000 (Arab Emirates Dirhams Five Thousand only). Where the fees charged are related to a number of Services, the amount of the fees will be apportioned for the purpose of the calculation of the maximum compensation, by reference to the estimated time involved in the performance of the Service from which the damage or loss derives. Any liability for indirect or consequential loss, damage or expense is specifically excluded. In any case, irrespective of the amount of the fees charged, the maximum damages payable by the Society will not be more than AED5,000,000 (Arab Emirates Dirhams Five Millions only). Payment of compensation under this paragraph will not entail any admission of responsibility and/or liability by the Society and will be made without prejudice to the disclaimer clause contained in paragraph 5.1 above.

5.3. Any claim for loss or damage of whatever nature by virtue of the provisions set forth herein shall be made to the Society in writing, within the shorter of the following periods: (i) THREE (3) MONTHS from the date on which the Services were performed, or (ii) THREE (3) MONTHS from the date on which the damage was discovered. Failure to comply with the above deadline will constitute an absolute bar to the pursuit of such a claim against the Society.

Article 6

6.1. These General Conditions shall be governed by and construed in accordance with United Arab Emirates (UAE) law, and any dispute arising from or in connection with the Rules or with the Services of the Society, including any issues concerning responsibility, liability or limitations of liability of the Society, shall be determined in accordance with UAE law. The courts of the Dubai International Financial Centre (DIFC) shall have exclusive jurisdiction in relation to any claim or dispute which may arise out of or in connection with the Rules or with the Services of the Society.

6.2. However,

- (i) In cases where neither the claim nor any counterclaim exceeds the sum of AED300,000 (Arab Emirates Dirhams Three Hundred Thousand) the dispute shall be referred to the jurisdiction of the DIFC Small Claims Tribunal; and
- (ii) for disputes concerning non-payment of the fees and/or expenses due to the Society for services, the Society shall have the

right to submit any claim to the jurisdiction of the Courts of the place where the registered or operating office of the Interested Party or of the applicant who requested the Service is located.

In the case of actions taken against the Society by a third party before a public Court, the Society shall also have the right to summon the Interested Party or the subject who requested the Service before that Court, in order to be relieved and held harmless according to art. 3.5 above.

Article 7

7.1. All plans, specifications, documents and information provided by, issued by, or made known to the Society, in connection with the performance of its Services, will be treated as confidential and will not be made available to any other party other than the Owner without authorisation of the Interested Party, except as provided for or required by any applicable international, European or domestic legislation, Charter or other IACS resolutions, or order from a competent authority. Information about the status and validity of class and statutory certificates, including transfers, changes, suspensions, withdrawals of class, recommendations/conditions of class, operating conditions or restrictions issued against classed ships and other related information, as may be required, may be published on the website or released by other means, without the prior consent of the Interested Party.

Information about the status and validity of other certificates and statements may also be published on the website or released by other means, without the prior consent of the Interested Party.

7.2. Notwithstanding the general duty of confidentiality owed by the Society to its clients in clause 7.1 above, the Society's clients hereby accept that the Society may participate in the IACS Early Warning System which requires each Classification Society to provide other involved Classification Societies with relevant technical information on serious hull structural and engineering systems failures, as defined in the IACS Early Warning System (but not including any drawings relating to the ship which may be the specific property of another party), to enable such useful information to be shared and used to facilitate the proper working of the IACS Early Warning System. The Society will provide its clients with written details of such information sent to the involved Classification Societies.

7.3. In the event of transfer of class, addition of a second class or withdrawal from a double/dual class, the Interested Party undertakes to provide or to permit the Society to provide the other Classification Society with all building plans and drawings, certificates, documents and information relevant to the classed unit, including its history file, as the other Classification Society may require for the purpose of classification in compliance with the applicable legislation and relative IACS Procedure. It is the Owner's duty to ensure that, whenever required, the consent of the builder is obtained with regard to the provision of plans and drawings to the new Society, either by way of appropriate stipulation in the building contract or by other agreement.

In the event that the ownership of the ship, product or system subject to certification is transferred to a new subject, the latter shall have the right to access all pertinent drawings, specifications, documents or information issued by the Society or which has come to the knowledge of the Society while carrying out its Services, even if related to a period prior to transfer of ownership.

Article 8

8.1. Should any part of these General Conditions be declared invalid, this will not affect the validity of the remaining provisions.

EXPLANATORY NOTE TO PART D

1. Reference edition

The reference edition of these Rules is the edition effective from 1 January 2015.

2. Effective date of the requirements

2.1 All requirements in which new or amended provisions with respect to those contained in the reference edition have been introduced are followed by a date shown in brackets.

The date shown in brackets is the effective date of entry into force of the requirements as amended by the last updating. The effective date of all those requirements not followed by any date shown in brackets is that of the reference edition.

2.2 Item 5 below provides a summary of the technical changes from the preceding edition. In general, this list does not include those items to which only editorial changes have been made not affecting the effective date of the requirements contained therein.

3. Rule Variations and Corrigenda

Until the next edition of the Rules is published, Rule Variations and/or corrigenda, as necessary, will be published on the Tasneef web site (www.tasneef.ae). Except in particular cases, paper copies of Rule Variations or corrigenda are not issued.

4. Rule subdivision and cross-references

4.1 Rule subdivision

The Rules are subdivided into five parts, from A to E.

Part A: Classification and Surveys

Part B: Hull and Stability

Part C: Machinery, Electrical Installations, Automation and Fire Protection

Part D: Materials and Welding

Part E: Additional Class Notations

Each Part consists of:

- Chapters
- Sections and possible Appendices
- Articles
- Sub-articles
- Requirements

Figures (abbr. Fig) and Tables (abbr. Tab) are numbered in ascending order within each Section or Appendix.

4.2 Cross-references

Examples: Pt A, Ch 3, Sec 1, [3.2.1] or Pt A, Ch 3, App 1, [3.2.1]

- Pt A means Part A

The part is indicated when it is different from the part in which the cross-reference appears. Otherwise, it is not indicated.

- Ch 3 means Chapter 3

The Chapter is indicated when it is different from the chapter in which the cross-reference appears. Otherwise, it is not indicated.

- Sec 1 means Section 1 (or App 1 means Appendix 1)

The Section (or Appendix) is indicated when it is different from the Section (or Appendix) in which the cross-reference appears. Otherwise, it is not indicated.

- [3.2.1] refers to requirement 1, within sub-article 2 of article 3.

Cross-references to an entire Part or Chapter are not abbreviated as indicated in the following examples:

- Part A for a cross-reference to Part A
- Part A, Chapter 1 for a cross-reference to Chapter 1 of Part A.

5. Summary of amendments introduced in the edition effective from 1 January 2020

Foreword

This edition of the Rules for the classification of Yachts Designed for Commercial Use contains amendments whose effective date is **1 January 2020**.

The date of entry into force of each new or amended item is shown in brackets after the number of the item concerned.



RULES FOR THE CLASSIFICATION OF YACHTS DESIGNED FOR COMMERCIAL USE

Part D Materials and Welding

Chapters **1 2 3 4 5 6**

Chapter 1	GENERAL REQUIREMENTS
Chapter 2	STEEL AND IRON PRODUCTS
Chapter 3	NON FERROUS METAL
Chapter 4	MISCELLANEOUS EQUIPMENT
Chapter 5	WELDING
Chapter 6	PLASTIC MATERIALS

CHAPTER 1

GENERAL REQUIREMENTS

Section 1 Manufacture, Inspection, Certification

1	General	13
1.1	Application	
1.2	Other specifications	
1.3	Information to be supplied by the purchaser	
2	Manufacture and quality	13
2.1	General	
2.2	Chemical composition	
2.3	Condition of supply	
2.4	Identification of products	
3	Inspection and testing	14
3.1	General conditions	
3.2	Alternative inspection scheme	
3.3	Sampling for mechanical tests	
3.4	Mechanical tests	
3.5	Re-test procedures	
3.6	Visual, dimensional and non-destructive examinations	
3.7	Repairs of defects	
4	Identification and certification	16
4.1	Identification and marking	
4.2	Documentation and certification	

Section 2 Testing Procedures for Materials

1	General	18
1.1	Application	
1.2	Testing machines	
1.3	Preparation of test specimens	
2	Tensile test	18
2.1	Test specimens	
2.2	Testing procedure	
3	Bend test	20
3.1	Flat bend test specimen	
3.2	Testing procedure	
4	Impact test	21
4.1	Sampling	
4.2	Charpy V-notch specimens	
4.3	Charpy U-notch specimens	
4.4	Testing procedure	

- 5.1 Flattening test
- 5.2 Drift expanding test
- 5.3 Flanging test
- 5.4 Ring expanding test
- 5.5 Ring tensile test
- 5.6 Bend test on pipes and tubes

CHAPTER 2

STEEL AND IRON PRODUCTS

Section 1 Requirements

1	General	27
1.1	Application	

CHAPTER 3 NON FERROUS METAL

Section 1 Requirements

1	General	31
1.1	Application	

CHAPTER 4

MISCELLANEOUS EQUIPMENT

Section 1 Equipment

1	Anchors	35
	1.1 Application	
	1.2 Design - Manufacture	
	1.3 Materials - testing	
	1.4 Visual and dimensional examination	
	1.5 Drop test and non-destructive examination	
	1.6 Proof load test	
	1.7 Identification, marking, certification	
2	Stud link chain cables and accessories	37
	2.1 Application	
	2.2 Chain cable grades	
	2.3 Approval of chain cable Manufacturers	
	2.4 Steels for chain cables	
	2.5 Rolled steel bars	
	2.6 Forged steels for chain cables and accessories	
	2.7 Cast steels for chain cables and accessories	
	2.8 Materials for studs	
	2.9 Design and manufacture	
	2.10 Testing of finished chain cables	
	2.11 Testing of accessories	
3	Studless chain cables	45
	3.1 Application	
	3.2 Materials for studless chain cables	
	3.3 Testing of finished chain cables	
4	Steel wire ropes	47
	4.1 Application	
	4.2 Manufacture	
	4.3 Types of ropes	
	4.4 Sampling and testing	
	4.5 Identification marking and certification	
5	Fibre ropes	56
	5.1 Application	
	5.2 Manufacture	
	5.3 Type of ropes	
	5.4 Sampling and testing	
	5.5 Identification, marking and certification	
6	Side scuttles, windows and their frames and glass panes	62
	6.1 Application	
	6.2 Manufacture	
	6.3 Inspections and tests	
	6.4 Identification and marking	
	6.5 Sidescuttle test	

Section 2 Various Finished Products

1	Cast copper alloy propellers and propellers blades	65
1.1	Application	
1.2	Manufacture	
1.3	Quality of castings	
1.4	Condition of supply	
1.5	Chemical composition	
1.6	Mechanical properties	
1.7	Sampling and testing	
1.8	Visual and dimensional examination	
1.9	Inspection - Severity zones Non-destructive examinations	
1.10	Repair procedures	
1.11	Identification and marking	
2	Pressure bottles	70
2.1	Application	
2.2	Manufacture	
2.3	Inspection and tests	
2.4	Identification, marking and certification	
3	Cast steel propellers and propeller blades	71
3.1	Application	
3.2	Manufacture	
3.3	Quality of castings	
3.4	Condition of supply	
3.5	Chemical composition	
3.6	Mechanical properties	
3.7	Sampling	
3.8	Visual and dimensional examination	
3.9	Non-destructive examinations - Severity Zones	
3.10	Repair procedures	
3.11	Identification	
3.12	Certification	

CHAPTER 5 WELDING

Section 1 Requirements

1	General	77
1.1	Application	

CHAPTER 6

PLASTIC MATERIALS

Section 1 General Requirements

1	Application	81
1.1	General	
1.2	Information on material quality and application	
1.3	Manufacture	
1.4	Inspection and testing	
1.5	Alternative inspection and testing	
1.6	Post-cure heating	
1.7	Test material	
1.8	Repairs of defects	
1.9	Identification of products and base materials	

Section 2 Tests on Resins, Reinforcements and Component

1	Scope	83
1.1		
2	Plywoods	83
2.1		
3	Adhesive and sealant materials	83
3.1		
4	Repair compounds	83
4.1		

Section 3 Testing During New Building

1	General	84
1.1		
2	Samples	84
2.1		
3	Testing	84
3.1		
4	Structural core materials	85
4.1		

Section 4 Plastic Pipes and Fittings

1	General	86
1.1	General	

Part D
Materials and Welding

Chapter 1

GENERAL REQUIREMENTS

SECTION 1 MANUFACTURE, INSPECTION, CERTIFICATION

SECTION 2 TESTING PROCEDURES FOR MATERIALS

SECTION 1

MANUFACTURE, INSPECTION, CERTIFICATION

1 General

1.1 Application

1.1.1 The provisions of this Part D are applicable as stated in the other Parts of these Rules. Chapter 2 to Chapter 4 and Chapter 6 specify the requirements for the manufacture, inspection and certification of steel and iron products, non-ferrous metals, plastic materials, various finished products and equipment such as propellers, pressure bottles, anchors, chain cables, ropes and sidescuttles, entering in the construction or repair of yachts which are surveyed for classification purposes.

The general requirements relevant to the manufacture, inspection and certification of the above-mentioned materials and products, hereafter generally referred to as "products", are given in this Chapter and are to be complied with as applicable.

The requirements of Chapter 1 are also applicable, when requested, as appropriate, to products covered by other parts of the Rules.

Part D specifies in Chapter 5 the requirements for approval of welding consumables and qualification of welding procedures.

1.1.2 In addition to Part D, the requirements given for certain materials, procedures and products in the other Parts of the Rules or specified on the approved plans, are also applicable, where appropriate.

1.1.3 Products subject to the requirements of Part D and the relevant testing operations are those laid down in the relevant Rules of ^{Tasneef} dealing with the design, inspection at works and testing of products, unless otherwise specified.

1.1.4 Products with properties departing appreciably from those covered by the Rules may be used with the approval of ^{Tasneef}

1.1.5 ^{Tasneef} will consider test procedures different from those indicated in this Part D.

In that case ^{Tasneef} will fix the relevant condition for acceptance.

1.1.6 In case ^{Tasneef} will ask for carrying out tests not considered in this Part D, it will do reference to Part D of "Rules of Classification of Ships" or as option it will do reference to procedures according to international Standards.

1.2 Other specifications

1.2.1 Products complying with international, national or proprietary specifications may be accepted by ^{Tasneef} provided such specifications give reasonable equivalence to

the requirements of these Rules or are approved for a specific application.

Such products, when accepted, are designated by their standard identification mark or as agreed at the time of the approval.

Unless otherwise agreed, inspection and certification of products complying with other specifications are to be carried out in accordance with the requirements of the Rules.

1.3 Information to be supplied by the purchaser

1.3.1 The purchaser is to provide the Manufacturer with the information necessary to ensure that products are tested in accordance with these Rules; optional or additional conditions are also to be clearly indicated.

2 Manufacture and quality

2.1 General

2.1.1 Manufacture

Manufacturers and their individual works are to be recognised by ^{Tasneef} for the type of products fabricated.

To this end plants, production and treatment procedures, testing machines, laboratories for analyses, internal control systems and personnel qualification are to be suitable in the opinion of ^{Tasneef}

Manufacturing procedures and techniques are to be such as to reasonably ensure constant compliance of the product with the requirements.

Where tests and analyses are performed by external laboratories or third parties, these are to be recognised by ^{Tasneef}

2.1.2 Approval

Depending on the type and importance of the products being supplied, the relevant manufacturing process may be required to be approved and approval tests performed for the purpose.

When approval of the manufacturing process is required, such condition is specified in the rule requirements relevant to the various products.

The provisions for the approval of Manufacturers are given in the "Rules for the approval of Manufacturers of materials".

2.1.3 Responsibility

Irrespective of the interventions of Surveyors, the Manufacturer is entirely and solely responsible for compliance of the supplied products with the stipulated requirements.

^{Tasneef} assumes no liability by its testing interventions in respect of the compliance of a tested product with the stipulated regulations and requirements.

Where, in the course of manufacture or after supply, a product is found not to be in compliance with the requirements or to present unacceptable defects, it will be rejected, irrespective of any previous satisfactory test results.

2.2 Chemical composition

2.2.1 The chemical composition is to be determined and certified, as a rule, by the Manufacturer using ladle sampling analysis. The laboratory is to be adequately equipped and the analyses are to be performed by qualified personnel.

2.2.2 The analyses of the Manufacturer are generally accepted subject to occasional checks, if required by the Surveyor. When checks on the product are required, they are to be performed and the results evaluated in accordance with recognised standards.

2.3 Condition of supply

2.3.1 Unless otherwise agreed, the products are to be supplied in the finished condition as per rules, including heat treatment if required.

Heat treatment is to be carried out in suitable and efficient furnaces, fitted with appropriate means for temperature control and recording.

The furnaces employed are to have a size sufficient to allow a uniform increase in temperature up to the required value of the whole furnace charge to be heat treated. In the case of very large parts, alternative systems proposed are to be agreed by Tasneef

Sufficient thermocouples are to be connected to the furnace charge to measure and record its temperature and check that it is adequately uniform, unless the temperature uniformity of the furnace is verified at regular intervals.

2.4 Identification of products

2.4.1 In the course of manufacturing, inspection and testing, the identification of the various products in respect of their origin is to be ensured as required.

To this end the Surveyor is to be given all facilities for tracing the products when required.

3 Inspection and testing

3.1 General conditions

3.1.1 As a rule, the inspections and tests are to be carried out at the Manufacturer's works before delivery.

If the necessary facilities are not available at the Manufacturer's works, the testing is to be carried out at a recognised testing laboratory.

3.1.2 Where the testing is allowed to be carried out or completed at works other than the Manufacturer's it is in any case to be possible to trace back with certainty to the documentation of the origin.

3.1.3 Interested parties are to apply for inspection in adequate time.

Prior to the inspection and testing, the Manufacturer is to provide the Surveyor with details of the orders, technical specifications and any special condition additional to the rule requirements.

3.1.4 The Surveyors are to have free access to all departments involved in production, collection of test samples, internal control and, in general, all operations concerning the inspection.

They are to be supplied with the information necessary to assess whether production and tests are performed according to the rule requirements.

3.1.5 All tests and checks required by the Rules are to be carried out in the presence of the Surveyors or, when expressly agreed with Tasneef in the presence of the person responsible for internal control, specially delegated for this purpose.

The inspection and testing activities may be delegated to the Manufacturer under the conditions given in [3.2].

3.1.6 The tests required are to be performed by qualified personnel in accordance with the procedures stated by Tasneef or, failing this, with recognised national or international standards.

The testing and measuring equipment is to be adequate, maintained in proper condition and regularly calibrated, as required; the record of such checks is to be kept up-to-date and made available to the Surveyor.

3.2 Alternative inspection scheme

3.2.1 Alternative procedures to the systematic intervention of the Surveyor for testing may be adopted by Manufacturers specially recognised by Tasneef for the purpose.

Such alternative inspection schemes, which are determined by taking into account the type of product, its mass production and the effectiveness of the certified Quality System implemented in the workshop, allow the testing operations indicated in these Rules to be totally or partially delegated to the Manufacturer.

Indications on the field of application of such schemes, along with conditions and procedures for their recognition, are given by Tasneef in a separate document.

3.3 Sampling for mechanical tests

3.3.1 The test samples are to be selected by the Surveyor or by a responsible person from the Manufacturer's staff, specially delegated, and are to be suitably marked for identification purposes.

3.3.2 The test samples are to be representative of the unit or lot of material which they are relevant to and are therefore also to have been subjected to the same heat treatment as the products except when a different procedure is agreed with Tasneef

3.3.3 For the purpose of test sampling the following definitions apply:

- a) unit: single forging, casting, plate, tube or other single product
- b) rolled unit: product rolled from the same slab or billet or, when rolling proceeds directly from ingots, from the same ingot
- c) batch: number of similar units or rolled units presented as a group for acceptance testing, on the basis of the tests to be carried out on the test sample
- d) sample: a sufficient quantity of material taken from the unit, rolled unit or batch, for the purpose of producing one or more test specimens
- e) test specimens: part of sample with specified dimensions and conditions for submission to a given test.

3.4 Mechanical tests

3.4.1 The mechanical tests are to be carried out in the presence of the Surveyor unless otherwise agreed; see [3.2].

3.4.2 For the check of the mechanical properties of the material, test methods and specimens in compliance with the requirements of Sec 2 are to be used.

3.4.3 The type of tests, the number and direction of the test specimens and the results of the tests are to comply with the requirements relevant to the type of product, as indicated in the various Articles.

3.5 Re-test procedures

3.5.1 General

Where the unsuccessful outcome of any test is attributable to defective machining of the test specimen and/or to improper test procedure, the negative result is disregarded and the test repeated, in correct conditions, on a substitute test specimen.

Where a test, other than an impact test, gives a result which is not in compliance with the requirements, two additional tests may be allowed to be performed on specimens of the same type taken from the same samples. For the purpose of acceptance, both tests are to comply with the requirements.

For the impact test, performed on a set of three test specimens, where the average value of the set does not comply with the required value, provided that not more than two test results are less than such value, with not more than one less than 70% of it, a second test may be allowed to be performed on three test specimens of the same type taken from the same samples.

For acceptance, the new average, calculated on the basis of the six results of the first and second sets of three test specimens taken together, is to comply with the required value, not more than two individual values are to be lower than the required average and, of these, not more than one is to be less than 70% of it.

3.5.2 Rejection or reconsideration

Where unsatisfactory results are obtained from re-tests representative of one lot of material, the unit from which the test specimens are taken is rejected.

The remainder of the lot may, at the discretion of the Surveyor, be reconsidered by performing the required tests on at least two different units; for acceptance, both the results of the new tests are to satisfy the requirements.

Otherwise, upon agreement with the Surveyor, the individual units composing the lot may be tested individually and those found satisfactory may be accepted.

The Manufacturer may resubmit for testing previously rejected material, after a suitable heat treatment or reheat treatment, or resubmit it under a different grade.

The Surveyor is to be notified of such circumstances.

Unless otherwise agreed by the Surveyor, only one new heat treatment is permitted for material which has already been heat treated.

3.6 Visual, dimensional and non-destructive examinations

3.6.1 General

The products are to be subjected to:

- a) visual examination
- b) dimensional check
- c) non-destructive examination, when applicable.

The above operations, to be effected on products in appropriate conditions, are carried out under the responsibility of the Manufacturer and are to be witnessed or repeated in the presence of the Surveyor when required by the Rules or, in any case, when it is deemed necessary by the Surveyor.

When, following examinations and tests, there are grounds for thinking a product may be defective, the Manufacturer is obliged, for the purpose of acceptance, to demonstrate its suitability using procedures deemed necessary.

3.6.2 Visual examination

Visual examination, unless otherwise specified, is performed by the Surveyor on each unit, for products tested on individual units and, randomly or on the units submitted to mechanical tests, for products tested by lot.

3.6.3 Dimensional check

The dimensional checks and verification of compliance with approved plans are carried out by the Surveyor, as deemed necessary, solely for those parts subject to approval, or where expressly required in Part D or other parts of the Rules.

3.6.4 Non-destructive examination

Non-destructive examination is to be performed by skilled and qualified personnel, using calibrated equipment of suitable type and according to approved procedures, recognised standards and the requirements of *Tasneef*

The Manufacturer's laboratory or other organisation responsible for the non-destructive examination is required to issue, on its own responsibility, a certificate illustrating the results and, where requested, an opinion concerning the acceptability of the product; in the latter case, the certificate is to be countersigned by the Manufacturer.

For the radiographic test suitable means are to be provided in order to identify the zones examined and the relevant radiographic films.

The various steps of the examinations are to be witnessed by the Surveyor when required. In such case the certificates are generally to be countersigned by the witnessing Surveyor.

3.7 Repairs of defects

3.7.1 Small surface defects may be suitably removed by grinding or other appropriate means, provided that the dimensional tolerances, prescribed for the various products in the relevant Articles, are complied with.

The repaired zone is to be found free from defects and to be acceptable in the opinion of the Surveyor.

3.7.2 Repairs by welding may be accepted only where this is not in contrast with the requirements applicable to the product, and provided that they are deemed suitable in connection with the material, extent of defects and welding procedure.

The repair procedure is to be previously agreed upon with the Surveyor.

4 Identification and certification

4.1 Identification and marking

4.1.1 General

During the inspection, a detailed record of the products to be tested is to be submitted to the Surveyor with indication of the necessary data, as applicable:

- a) name of purchaser and order number
- b) hull number or destination
- c) number, size and mass of parts or batches
- d) cast number and chemical composition
- e) part reference number, detail of manufacturing process and heat treatment
- f) condition of supply.

4.1.2 Manufacturer's marking

Products, which have satisfactorily undergone the required inspection and tests are to be appropriately marked by the Manufacturer in at least one easily accessible location.

The marking is to contain all necessary indications, as specified in the Articles relevant to the various products, and is to correspond to the content of the inspection documentation.

The marks are to be stamped, as a rule, by means of brands, except when products could be impaired by such a system. When paints or other reliable alternatives are adopted, adequate duration of marking is to be ensured.

For small pieces contained in effective containers, as well as bars and sections of modest weight, adequately bound in bundles, the marks are transferred to the container, label or top item of each bundle to the Surveyor's satisfaction.

4.1.3 Marking with Tasneef brand

The products satisfactorily inspected in accordance with the Rules are to be marked with Tasneef brand in the presence of the Surveyor unless otherwise agreed between Manufacturer and Surveyor.

All other additional marks required are specified in the applicable Articles depending on the products (e.g. name or initials of Manufacturer, material, grade and cast number, code for calendar year, running file number and code of the local office inspection, Surveyor's personal brand, TP as statement of hydrostatic test).

4.1.4 Tasneef marking for incomplete inspection

Whenever a product is despatched for delivery or is to be marked without undergoing all the inspections and tests required (whether by the provisions of Part D or those of other parts of the Rules), Tasneef brand will be replaced by Tasneef mark for incomplete inspection.

The testing documents are to contain clear indications of all outstanding inspections and tests and specify the reason why they have not been performed.

Upon satisfactory completion of all required tests, the product is to be stamped with Tasneef brand.

4.1.5 Invalidation of Tasneef brand

When a product already marked with one of Tasneef stamps is found during or subsequent to the testing not to be in compliance with the requirements and is therefore rejected, the previously stamped marks are to be invalidated by punching them.

The Surveyors may request to check the invalidation effected.

Any repairs after the product is tested are subject to the prior consent of Tasneef failing this, the validity of the original testing will automatically expire and the original testing marks are to be invalidated by the interested parties.

4.1.6 Tasneef brand for alternative inspection scheme

In the case of admission to an alternative inspection scheme, the marking with Tasneef brand may be delegated to the Manufacturer, who will be supplied with the special brand to be used for this purpose.

4.2 Documentation and certification

4.2.1 Tasneef inspection certificate

For products tested with satisfactory results, Tasneef issues an inspection certificate signed by the Surveyor stating that the products have been tested in accordance with Tasneef Rules.

This certificate is identified by the letter C for ease of reference in the various parts of the Rules.

An inspection certificate issued by the Manufacturer is to be attached to Tasneef certificate and is to include, as applicable, the following particulars:

- a) Manufacturer's name
- b) purchaser's name, order number and hull number
- c) description of the product, dimensions and weight
- d) results of all specified inspections and tests, including non-destructive tests where applicable

e) identification and testing marks stamped on the products.

In the case of testing of materials, the following particulars are also to be included:

- identification of specification or grade of material
- identification of the heat and relevant chemical analysis
- supply condition and the specification of heat treatment, if carried out, including temperature and holding time
- working and manufacturing procedure (for rolled products intended for hull, boilers and pressure vessels only)
- declaration that the material has been made by an approved process, as applicable, and that it has been subjected with satisfactory results to the tests required by the Rules.

By agreement with ^{Tasneef} the inspection certificate issued by the Manufacturer may be directly confirmed by endorsement with ^{Tasneef} brand and the signature of the Surveyor.

For products manufactured in large quantities and tested by heats or by lot, the Manufacturer is to further state, for the individual supplies, that the products have been produced according to ^{Tasneef} Rules.

4.2.2 ^{Tasneef} inspection certificate for alternative inspection scheme

For products covered by the alternative inspection scheme, unless otherwise stated in the admission to the alternative

inspection scheme, the Manufacturer is to issue a Certificate of Conformity on the appropriate ^{Tasneef} form.

This certificate is identified by the letter CA (certificate for alternative survey) for ease of reference in the various parts of the Rules.

The inspection certificate issued by the Manufacturer and including all the information required in [4.2.1] is to be attached to the (CA) certificate.

The certificate is to be submitted to ^{Tasneef} for endorsement according to the procedures stated in the agreement for the alternative survey scheme.

4.2.3 Works' certificates

For products which in accordance with the relevant rules may be accepted only on the basis of a certificate of conformity issued by the Manufacturer, stating the results of the tests performed, such certificate is to contain the information required under [4.2.1], as applicable.

This certificate of conformity is identified by the letter W (works' certificate) for ease of reference in the various parts of the Rules.

For particular products it may be accepted that the tests or inspections are carried out by the ManufacturerManufacturer not on the product supplied, but on the current production.

This particular certificate of conformity is identified by the letter R (report) for ease of reference in the various parts of the Rules.

SECTION 2

TESTING PROCEDURES FOR MATERIALS

1 General

1.1 Application

1.1.1 This Section specifies the requirements for testing procedures, testing machines and test specimens for mechanical and technological tests of materials.

The testing procedures and test specimens relevant to welding are specified in Chapter 5.

The Articles of the Rules, dealing with the various products, indicate the examinations and tests required together with the results to be obtained.

The general conditions specified in Sec 1 also apply.

1.2 Testing machines

1.2.1 Testing machines are to be of a recognised type, kept in a satisfactory condition and calibrated by Tasneef or by a recognised body in accordance with a recognised standard, at approximately annual intervals.

In particular for tensile machines the permitted indication errors are to be within the values specified in ISO 7500 for Class 1.

The records of the calibration are to be made available to the Surveyor and kept in the test laboratory.

1.3 Preparation of test specimens

1.3.1 The samples for test specimens are to be in the same condition as the product from which they have been taken and therefore in the same heat treatment condition, if any.

1.3.2 If the test samples are cut from products by flame cut, when admissible depending on the kind of material, or shearing, a reasonable margin is required to enable sufficient material to be removed from cut or sheared edges during final machining.

Test specimens are to be obtained from samples by mechanical cuts; care should be taken in their preparation to avoid any significant straining or heating which might alter the properties of the material.

2 Tensile test

2.1 Test specimens

2.1.1 Proportional flat specimen

For flat products, rectangular specimens of proportional type are generally used, having dimensions as shown in Fig 1.

Figure 1 : Proportional flat specimen

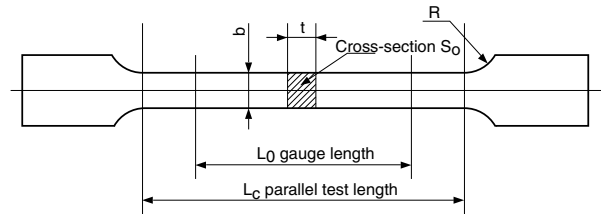

- t : thickness of the considered material
 b : 25 mm
 L_0 : $5,65S_0^{1/2}$ where S_0 is the specimen cross section. The gauge length may be rounded off the nearest 5 mm provided that the difference between the computed L_0 and that rounded length is less than 10% of L_0
 L_c : $L_0 + 2S_0^{1/2}$
 R : 25 mm

For such products the tensile test specimens are to retain the original raw surfaces of the product.

However, for thickness equal to or greater than 40 mm, or, more generally, when the testing machine capacity does not allow testing of specimens of full thickness, this may be reduced by machining one of the raw surfaces.

2.1.2 Non-proportional flat specimen

As an alternative to the specimen mentioned above, non-proportional specimens may also be used; in particular a rectangular specimen, having fixed gauge length of 200 mm and other dimensions as shown in Fig 2, may be used.

2.1.3 Round specimen

As stated in [2.1.1], for rolled products, excluding bars, the tensile test specimens are to retain the original raw surfaces of the product.

However, for thickness equal to or greater than 40 mm, or, more generally, when the testing machine capacity does not allow testing of specimens of full thickness, this may be reduced by machining one of the raw surfaces.

Figure 2 : Non proportional flat specimen

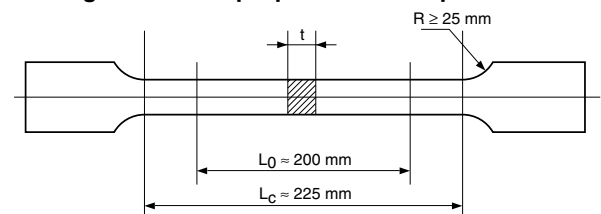

- t : thickness of the considered flat material.

Alternatively, a round proportional test specimen, machined to the dimensions shown in Fig 3, may be used.

For long rolled products (bars and profiles), forgings and castings, grey cast iron excluded, cylindrical specimens of

proportional type, having in general diameter of 10 or 14 mm, are to be used.

Figure 3 : Round proportional specimen

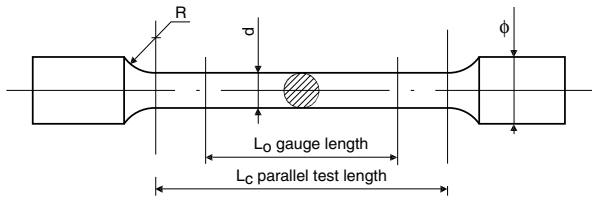

2.1.4 Round specimen diameter

The proportional round tensile specimens generally have diameter of 10 or 14 mm.

However others diameters, in general 8 or 6 mm, may be used in specific cases when the selection of normal size test specimens is not possible.

2.1.5 Round specimen position

In the case of rolled products (plates), with thickness equal to or greater than 40 mm, the axis of the round test specimen is to be located at approximately one quarter of the thickness from one of the rolled surfaces.

In the case of bars and similar products, the axis of the round test specimen is to be located at one third of the radius from the outside.

In the case of forged products, unless otherwise agreed, the longitudinal axis of test specimens is to be positioned as follows:

- a) for thickness or diameter up to maximum 50mm, the axis is to be at the mid-thickness or the centre of the cross section;
- b) for thickness or diameter greater than 50mm, the axis is to be at one quarter thickness (mid-radius) or 80mm, whichever is less, below any heat treated surface.

2.1.6 Specimen for grey cast iron

For grey cast iron, the test specimen as shown in Fig 4 is to be used.

Figure 4 : Specimen for grey cast iron

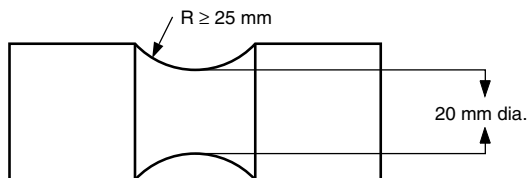

2.1.7 Specimens for pipes and tubes

For testing of pipes and tubes, the testing specimen may be a full cross-section of suitable length to be secured in the testing machine with plugged ends, as shown in Fig 5.

The gauge length L_0 is to be equal to:

$$L_0 = 5,65 \sqrt{S_0}$$

and the distance between the grips L_t is to be not less than the gauge length plus D , where D is the external diameter of the tube or pipe.

The length of the plugs projecting over the grips, in the direction of the gauge marks, is not to exceed the external diameter D , and the shape of the plugs is not to impede the elongation of the gauge length.

Figure 5 : Full cross section specimen

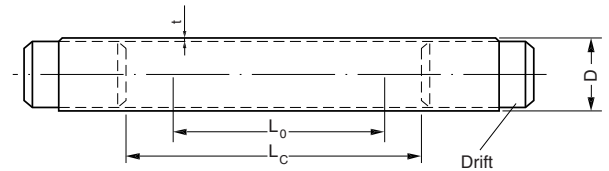

Alternatively test specimens are to be taken from the tube or pipe wall, as shown in Fig 6, where:

$$L_0 = 5,65 \sqrt{S_0}$$

$$L_c = L_0 + 2 b$$

Figure 6 : Specimen taken from the tube or pipe wall

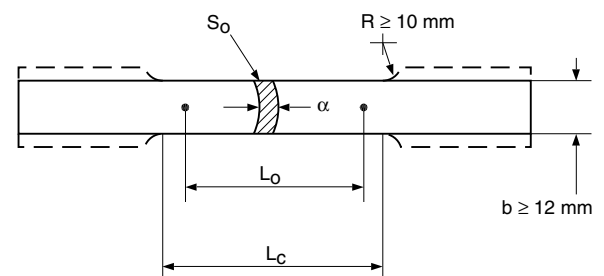

Where the wall thickness is sufficient to allow machining, the round specimen indicated in Fig 3 may be used, with the axis located at the mid-wall thickness.

2.1.8 Specimen for wires

For testing of wires, a full cross-section test specimen of suitable length is to be used.

The gauge length is to be 200 mm and the parallel test length (distance between the grips) is to be 250 mm.

2.1.9 Dimensional tolerances

The dimensional tolerances of test specimens are to be in accordance with ISO 6892-84 or other recognised standards as appropriate.

2.2 Testing procedure

2.2.1 General

The following characteristics, as required by the different products, are to be determined by the test:

- a) R_{eH} : Yield stress (yield point), in N/mm^2
- b) $R_{p0,2}$ - $R_{p0,5}$ - $R_{p1,0}$: Proof stress (yield strength), in N/mm^2
- c) R_m : Tensile strength, in N/mm^2
- d) A: Percentage elongation at fracture
- e) Z: Percentage reduction of area.

2.2.2 Yield and proof stress determination

For materials with well defined yield phenomenon, the yield stress R_{eH} is the value corresponding to the first stop or

drop of the index, showing the load applied by the testing machine in the tensile tests at ambient temperature.

This applies, unless otherwise specified, to products of carbon steels, carbon-manganese steels and alloy steels, except austenitic and duplex stainless steels.

For materials which do not present a manifest yield stress, as defined above, the product requirements determine the conventional proof stress R_p to be assumed.

In general, for steels, the conventional stress to be assumed is the 0,2 per cent proof stress or the 0,5 per cent proof stress, designated by the symbols $R_{p0,2}$ and $R_{p0,5}$, respectively, where 0,2 and 0,5 are the percentage of permanent deformation.

For austenitic and duplex stainless steel products and relevant welding consumables, the 1,0 per cent proof stress, designated by the symbol $R_{p1,0}$, may be required in addition or as an alternative.

2.2.3 Load application rate

For ductile material, the load application rate, before reaching the actual or conventional yield stress, is not to exceed 30 N/mm² per second, while afterwards, when approaching the rupture stress, it is to be such that the deformation rate does not exceed 40 per cent of the gauge length per minute.

For brittle materials like cast iron and non-ferrous metals, the load application rate, up to the rupture stress, is not to exceed 10 N/mm² per second.

2.2.4 Elongation

The per cent elongation is in general determined on a proportional gauge length L_0 .

L_0 is determined by the following formula:

$$L_0 = 5,65 \sqrt{S_0}$$

where:

S_0 : Original cross-sectional area of the test specimen.

In the case of round solid specimens, L_0 is 5 diameters.

The per cent elongation is also defined as short proportional elongation or A_5 .

When a gauge length other than L_0 is used, the equivalent per cent elongation A_x required is obtained from the following formula:

$$A_x : 2A_5 \left(\frac{\sqrt{S}}{L} \right)^{0,4}$$

where:

A_5 : Minimum elongation, in per cent, required by the Rules for the proportional specimens illustrated in Fig 1, Fig 3 and Fig 6

S : Area, in mm², of the original cross-section of the actual test specimen

L : Length, in mm, of the corresponding gauge length actually used.

The above conversion formula may be used only for non-cold formed ferritic products with tensile strength not exceeding 700 N/mm².

The extension of the formula to other applications, such as cold worked steels, austenitic steels or non-ferrous materials is to be agreed upon with Tasneef Surveyors.

In the case of disagreement, the value of elongation computed on the proportional specimen is to be taken.

The gauge length to which the elongation is referred is to be indicated in the test reports.

For non-proportional test specimens with gauge length of 50 mm and 200 mm, the equivalent elongation values indicated in ISO 2566 apply.

The elongation value may be considered valid if the fracture position is at a distance from the ends of the gauge length of at least 1,25 times the specimen diameter, for a circular cross-section, or at least the sum of the width and thickness of the specimen, for a rectangular section.

The appearance of the fracture of test specimens after the tensile test is always to be examined. The appearance of the fracture section is to be sound and free from defects and irregularities.

2.2.5 Testing at elevated temperature

For testing at elevated temperature, the determination of 0,2 per cent proof stress is to have a gauge length for strain measurement not less than 50 mm and a cross-sectional area not less than 65 mm². However, if the dimensions of the product or the available test equipment do not allow such conditions, the largest possible dimension is to be used.

As yield stress the conventional value of 0,2 per cent proof stress is generally taken; the deformation rate immediately prior to reaching the yield stress is to be in the range between 0,1 and 0,3 per cent of the gauge length per minute.

The intervals between deformation measurements to assess the above-mentioned rate are not to exceed 6 seconds.

The equipment is to permit a test temperature control within a tolerance range $\pm 5^\circ\text{C}$.

3 Bend test

3.1 Flat bend test specimen

3.1.1 A flat bend test specimen as shown in Fig 7 is to be used.

The edges on the tension side are to be rounded to a radius of 1 to 2 mm.

The length of the specimen is to be at least 11 times the thickness or 9 times the thickness plus the mandrel diameter, if this value is higher.

Figure 7 : Flat bend specimen

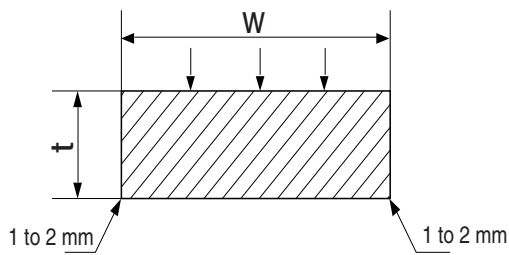

3.1.2 For castings, forgings, and half rough products, the other dimensions are to be as follows:

thickness: $t = 20$ mm,
width: $w = 25$ mm.

3.1.3 For rolled products the other dimensions are to be as follows:

thickness: $t =$ thickness of product,
width: $w = 30$ mm.

If the thickness of the rolled product is greater than 25 mm, the thickness of the specimen may be reduced to 25 mm by machining the surface of the specimen that is to be in compression during the test.

3.2 Testing procedure

3.2.1 The bend test is to be performed, as a rule, by applying a continuous mechanical compressive action on one of the surfaces of the test specimen.

The required mandrel diameter and the minimum bend angle are specified in the Articles dealing with the various products.

The test is satisfactory if the required bend angle is reached without incipient fracture.

4 Impact test

4.1 Sampling

4.1.1 The impact test is, in general, to be determined on a set of 3 notched specimens.

The longitudinal axis of the notched test specimens can be:

- a) parallel to the rolling direction of the plate, of the section, or of the piece (longitudinal direction L)
- b) perpendicular to the rolling direction of the plate or of the piece (transverse direction T)
- c) parallel to other directions of selection.

The test specimens are to be of the V-notch or U-notch type, as required in the specifications of the various products and are designated KV and KU, respectively.

Depending on whether the Charpy test specimens have been taken in the lengthwise direction (L) or in the cross-wise direction (T), the symbol L or T is added, respectively, to the Charpy designation.

4.1.2 The axis of the notch is to be perpendicular to the faces of the plate, section or piece.

The position of the notch is to be not nearer than 25 mm to a flame cut or sheared edge.

4.1.3 For rolled products, the impact test specimens are to be taken, in the case of thickness not higher than 40 mm, retaining the original raw surface of the product or within 2mm from it.

In the case of thickness higher than 40 mm, the test specimens are to be taken with their longitudinal axis located at a position lying 1/4 of the product thickness, or as near as possible to such position.

For forged products, the longitudinal axis of the specimens is to be located in the way of the external third of the distance between the centre (or the inside surface) of the piece and its external surface, considering a typical section of the forging.

4.2 Charpy V-notch specimens

4.2.1 The specimens are to be fully machined at the dimensions and tolerances shown in Fig 8 and Tab 1.

Figure 8 : Charpy V-notch specimen

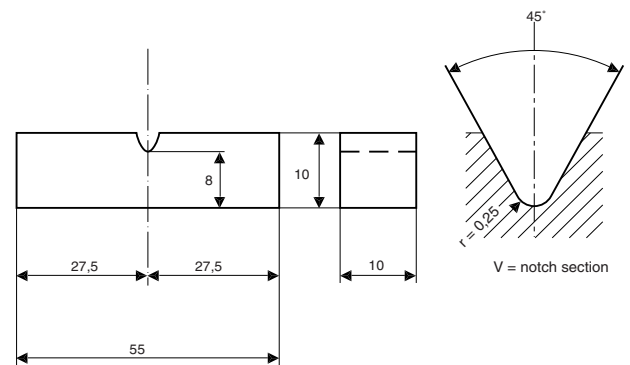

Table 1 : Charpy V-notch specimen

Dimensions	Nominal	Tolerance
Length	55 mm	± 0,60 mm
Width		
• standard specimen	10 mm	± 0,11 mm
• subsize specimen	7,5 mm	± 0,11 mm
• subsize specimen	5,0 mm	± 0,06 mm
Thickness	10 mm	± 0,06 mm
Depth below notch	8 mm	± 0,06 mm
Angle of notch	45 °	± 2°
Root radius	0,25 mm	± 0,025 mm
Distance of notch from end of test specimen	27,5 mm	± 0,42 mm
Angle between plane of symmetry of notch and longitudinal axis of test specimen	90°	± 2°

4.2.2 Specimens with reduced sectional area 10x7,5 or 10x5 may be used when the product thickness does not permit machining of the standard size.

The required energy values are given in Tab 2.

Table 2 : Average energy value for reduced specimens

Sectional area of V-notch specimens (mm ²)	Minimum average energy (1)
10 x 10	KV
10 x 7,5	5/6 KV
10 x 5	2/3 KV

(1) KV is the required value on standard size specimens, as per the Rules.

4.3 Charpy U-notch specimens

4.3.1 The specimens are to be fully machined at the dimensions and tolerances shown in Fig 9 and Tab 3.

Figure 9 : Charpy U-notch specimen

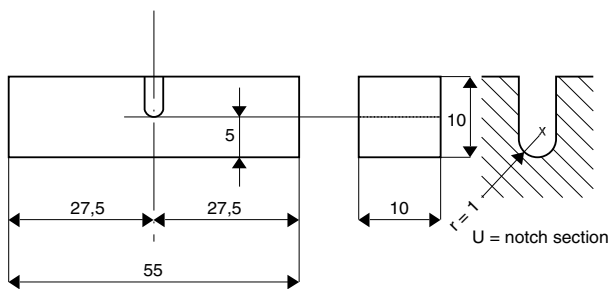

Table 3 : Charpy U-notch specimen

Dimensions	Nominal	Tolerance
Length	55 mm	± 0,60 mm
Width	10 mm	± 0,11 mm
Thickness	10 mm	± 0,06 mm
Depth below notch	5 mm	± 0,09mm
Root radius	1 mm	± 0,07 mm
Distance of notch from end of test specimen	27,5 mm	± 0,42 mm
Angle between plane of symmetry of notch and longitudinal axis of test specimen	90°	± 2°

4.4 Testing procedure

4.4.1 Unless otherwise specified, tests on U-notch type specimens are to be carried out at ambient temperature.

The term "ambient temperature" means any temperature within the range 18 to 28°C.

Tests on V-notch type specimens are to be carried out at or below ambient temperature, in compliance with the

requirements of the parts of the Rules relevant to the individual products and uses.

Where the test temperature is lower than ambient, the temperature of the specimen at the moment of the breaking is to be the specified test temperature, within plus minus 2°C.

The test temperature is to be clearly specified in the testing documents.

4.4.2 For impact tests carried out on a set of three specimens, the Charpy impact toughness is the average adsorbed energy, expressed in Joule (J), resulting from the set.

The average of the results on the three specimens is to comply with the value required for the product in question, and one individual test result may be less than the required average value, provided that it is not less than 70% of it.

5 Ductility tests for pipes and tubes

5.1 Flattening test

5.1.1 The specimen consists of a ring cut with the ends perpendicular to the axis of the pipe or tube.

The length of the specimen is to be equal to 1,5 times the external diameter of the pipe or tube, but is to be neither less than 10 mm nor greater than 100 mm; alternatively, a fixed length of 40 mm may be accepted.

The edges of the test pieces are to be rounded by filing before the test.

5.1.2 The test consists of compressing the specimen between two rigid and parallel flat plates in a direction perpendicular to its longitudinal axis; the plates are to cover the whole specimen after flattening.

It is to be continued until the distance Z between the two plates, measured under load, reaches the value specified.

In the case of welded pipes or tubes, the test is to be carried out with the welded seam positioned at 90° and at 0° to the flattening force.

After flattening, the specimen is not to present any cracks or other flaws; however, small cracks at the ends may be disregarded.

5.2 Drift expanding test

5.2.1 The specimen consists of a tube section having the ends perpendicular to the tube axis; the edges of the end to be tested may be rounded by filing.

5.2.2 For steel tubes the length of the specimen is to be equal to twice the external diameter of the tube, if the angle of the drift is 30°, or equal to the external diameter of the tube if the angle is 45°, 60° or 120°.

In any case the length of the specimen is to be not less than 50 mm.

5.2.3 For copper and copper alloy tubes, the length of the specimen is to be not less than twice but not more than three times the external diameter of the tube.

5.2.4 For aluminium and light alloy tubes the length of the specimen is to be not less than twice the external diameter.

5.2.5 The test consists of flaring the end of the specimen at ambient temperature and symmetrically, by means of a truncated-cone shaped mandrel of hardened steel having the included angle specified in [5.2.2] (Fig 10).

The mandrel is to be lubricated but is not to be rotated in the pipe during the test.

The mandrel penetration is to continue until the increase in external diameter of the end of the expanded zone reaches the value specified in the requirements relevant to the various products.

The expanded zone of the specimen is not to present any cracks or other flaws.

Figure 10 : Drift expanding test

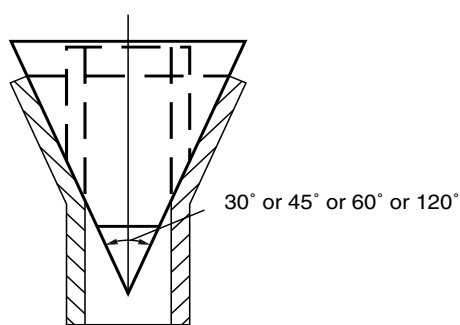

5.3 Flanging test

5.3.1 The specimen consists of a tube section cut with the ends perpendicular to the tube axis and length at least equal to the external diameter of the tube; the edges of the end to be tested may be rounded by filing.

5.3.2 The test is carried out in two stages and consists of symmetrically forming a flange at one end of the specimen by means of a special mandrel of hardened steel; the mandrel is to be lubricated but is not to be rotated in the tube during the test.

During the first stage of flanging, the end of the specimen is expanded by means of a truncated-cone shaped mandrel having an included angle of 90°; the test is then continued during the second stage using a special forming mandrel to complete the flange.

The test is to be continued until the expanded zone forms a flange perpendicular to the longitudinal axis of the specimen, with an increase in the external diameter of the end of the specimen not less than the value specified (Fig 11).

The cylindrical and flanged portion of the specimen is not to present any cracks or other flaws.

After testing, the remaining cylindrical portion is to be not less than half the external diameter of the tube.

Figure 11 : Flanging test

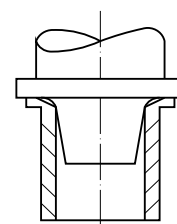

5.4 Ring expanding test

5.4.1 The specimen consists of a tube section cut with the ends perpendicular to the tube axis and the length between 10 and 16mm.

5.4.2 The specimen is to be expanded to the prescribed diameter or until fracture occurs (Fig 12).

The expanded specimen is not to reveal unacceptable defects such as cracks, grooves or laminations and is to reach the prescribed expansion.

Figure 12 : Ring expanding test

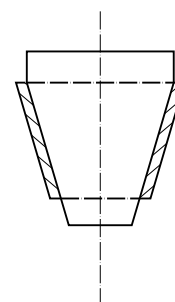

5.5 Ring tensile test

5.5.1 The specimen consists of a tube section with plain and smoothed ends cut perpendicular to the tube axis and with a length of about 15 mm.

5.5.2 The specimen is to be drawn to fracture in a tensile testing machine by means of two mandrels having diameter equal to at least three times the wall thickness of the pipe.

In the case of welded pipes the weld seam is to be at 90° to the direction of the tensile load.

The specimen after fracture is not to reveal unacceptable defects such as cracks, groves or laminations and is to show visible deformation at the point of fracture.

5.6 Bend test on pipes and tubes

5.6.1 Where feasible, the test specimen consists of full thickness strips not less than 40 mm in width (which may be machined down to 20 mm width for large thickness pipes) cut perpendicular to the pipe axis.

The edges of the specimen may be rounded to 1,5 mm radius.

The result is considered satisfactory if, after being bent through the required angle in the direction of the original curvature, the specimen is free from cracks and laminations; however, small cracks on the edges may be disregarded.

5.6.2 For small diameter tubes, in general not exceeding 50 mm, the specimen consists of a tube section of sufficient length.

The specimen is to be bent on a cylindrical mandrel with appropriate procedures as follows, depending on the specification of the product:

- a) on a mandrel having a diameter 12 times the nominal diameter of the tube until an angle of 90° is reached
- b) on a mandrel having a diameter 8 times the nominal diameter of the tube, until an angle of 180° is reached.

The specimen after bending is not to present any cracks or other flaws.

Part D
Materials and Welding

Chapter 2
STEEL AND IRON PRODUCTS

SECTION 1 REQUIREMENTS

SECTION 1 REQUIREMENTS

1 General

1.1 Application

1.1.1 (1/1/2023)

Reference is to be made, as far as practicable, to the applicable requirements in Pt D, Ch 2 of the ^{Tasneef} Rules for the Classification of Ships.

Part D
Materials and Welding

Chapter 3
NON FERROUS METAL

SECTION 1 REQUIREMENTS

SECTION 1 REQUIREMENTS

1 General

1.1 Application

1.1.1 (1/1/2023)

Reference is to be made, as far as practicable, to the applicable requirements in Pt D, Ch 3 of the ^{Tasneef} Rules for the Classification of Ships.

Part D
Materials and Welding

Chapter 4

MISCELLANEOUS EQUIPMENT

SECTION 1 EQUIPMENT

SECTION 2 VARIOUS FINISHED PRODUCTS

SECTION 1 EQUIPMENT

1 Anchors

1.1 Application

1.1.1 General

The requirements of this Article apply to anchors and associated components (heads, shanks and shackles) made of cast or forged steel, or fabricated by welding from rolled steel.

1.1.2 Modified testing procedure

For anchors having mass lower than 100 kg, or 75 kg in the case of high holding power anchors, continuously produced by Manufacturers who have been approved by Tasneef for this purpose, a batch testing procedure is admitted, with random execution of the checks required for normal testing.

The composition of the batches is to be judged appropriate as regards the homogeneity of material, manufacturing, heat treatment and dimensions.

1.2 Design - Manufacture

1.2.1 (1/1/2019)

Anchors are to be manufactured by recognised Manufacturers, according to approved plans or recognised standards.

For approval and/or acceptance of high holding power (HHP) and super high holding power (VHHP) anchors, the type tests indicated in Pt B, Ch 1, Sec 3, [2.1] are to be carried out.

The manufacture of steel forgings and castings for anchors is to comply with the applicable requirements of Ch 2, Sec 3 and Ch 2, Sec 4, respectively, and are to be manufactured by recognised Manufacturers.

Welded anchors are to be manufactured in accordance with approved procedures.

1.2.2 The mass of anchors and the percentages of the mass of components in relation to the total mass are to be as required in the various parts of the Rules relevant to the equipment.

1.3 Materials - testing

1.3.1 Materials are to comply with the approved plans or the unified requirement or standard applied; the requirements of Ch 2, Sec 1, [2], Ch 2, Sec 3, [2] and Ch 2, Sec 4, [2] relevant to rolled, forged or cast steels are applicable as far as appropriate.

1.3.2 The mechanical tests of the material are to be carried out in compliance with the requirements of Chapter 2.

For stockless anchors, the testing is to cover heads and shanks.

1.4 Visual and dimensional examination

1.4.1 Visual examination

Each anchor is to be submitted to visual examination in order to ascertain, in addition to the absence of imperfections of harmful nature, that surface condition is smooth and uniform. The individual pieces are to be subjected to this examination in a clean condition and without paint.

1.4.2 Check of mass and dimensions

The check is to be performed by the Manufacturer measuring the total mass, the mass of each component and the main dimensions. The Surveyor may wish to witness such measurements or to perform random checks at his discretion; the Manufacturer is to issue a certificate detailing the masses measured, to be attached to the testing documentation.

1.5 Drop test and non-destructive examination

1.5.1 Drop test

The drop test is to be performed on cast anchors by dropping the anchor from a height of 3,6m in compliance with an agreed procedure, on a steel platform 100 mm thick, with masonry foundation 1,2m deep.

1.5.2 Non-destructive examination

Non-destructive examination, in compliance with a procedure to be agreed upon, may be carried out as an alternative to the drop test and is always required for cast anchors weighing more than 10000 kg.

1.6 Proof load test

1.6.1 General

Each forged or cast steel anchor, complete in all its parts, is to be subjected, in the presence of the Surveyor, to a proof loading test at the load indicated in Tab 1 depending on the mass.

This requirement may be waived for anchors having a mass of 15000 kg and over, subject to special conditions stipulated in each case.

The following mass is to be used in determining the test load:

- for stocked anchors, the mass of the anchor without the stock
- for stockless anchors, the total mass of the anchor
- for high holding power anchors, a mass equal to 1,33 times the total mass of the anchor
- for very high holding power anchors, a mass equal to twice the total mass of the anchor.

1.6.2 Proof load test specifications

The load is to be applied between the shackle at one end and, at the other end, the arm/arms at a point located approximately one third of the length from its/their end. The test is to be performed in duplicate, in accordance with the following procedure:

- for anchors having four fixed arms, the load is to be applied first to one pair of arms and then to the opposite pair, applying it simultaneously to the pair concerned
- for stocked anchors with two fixed arms, the load in both tests is to be applied separately to both arms
- for stockless anchors with hinged arms, the load is to be applied in both opposite anchoring positions, and in each test it is to be applied simultaneously to the points of the arms mentioned above.

As far as the point of application of the load on the arms is concerned, the length of the arm is defined as :

- the length between the tip of each arm and the crown of the anchor, or
- the distance between the tips of the arms and the axis of rotation, in the case of stockless anchors with hinged arms.

For further details on the proof test, see Fig 1.

The difference between the gauge lengths *a*, defined in Fig 1, measured when the applied load is equal to 10% of the proof load and when the applied load is reduced from the proof load to 90% of the proof load, may not exceed 0,01 *a*.

Table 1 : Proof load test

Mass (kg)	Proof load (kN)	Mass (kg)	Proof load (kN)	Mass (kg)	Proof load (kN)	Mass (kg)	Proof load (kN)
50	23,2	550	124	2200	375	4800	645
55	25	600	132	2300	385	4900	653
60	27	650	140	2400	400	5000	661
65	29	700	149	2500	410	5100	669
70	31	750	158	2600	425	5200	677
75	32,5	800	166	2700	435	5300	685
80	34	850	175	2800	450	5400	691
90	36	900	182	2900	460	5500	699
100	39	950	191	3000	470	5600	706
120	44	1000	199	3100	480	5700	713
140	49	1050	208	3200	495	5800	721
160	53	1100	216	3300	505	5900	728
180	57	1150	224	3400	515	6000	735
200	61	1200	231	3500	525	6100	740
225	67	1250	239	3600	535	6200	747
250	70	1300	247	3700	545	6300	754
275	75	1350	255	3800	555	6400	760
300	79	1400	262	3900	565	6500	767
325	84	1450	270	4000	575	6600	773
350	88	1500	278	4100	585	6700	779
375	93	1600	292	4200	585	6800	785
400	97	1700	307	4300	600	6900	794
425	102	1800	321	4400	610	7000	804
450	106	1900	335	4500	620	7200	818
475	111	2000	349	4600	630	7400	832
500	115	2100	362	4700	635	7600	845

Note 1: Masses shown refer either to stockless anchors or to stocked anchors excluding stocks. The proof load for intermediate masses may be determined by linear interpolation.

Note 2: For high holding power (HHP) anchors, the required proof load is derived from the Table, using a mass equal to 1,33 times the actual mass of the HHP anchor.

Note 3: For very high holding power (VHHP) anchors, the required proof load is derived from the Table, using a mass equal to twice the actual mass of the VHHP anchor.

Figure 1 : Proof load test

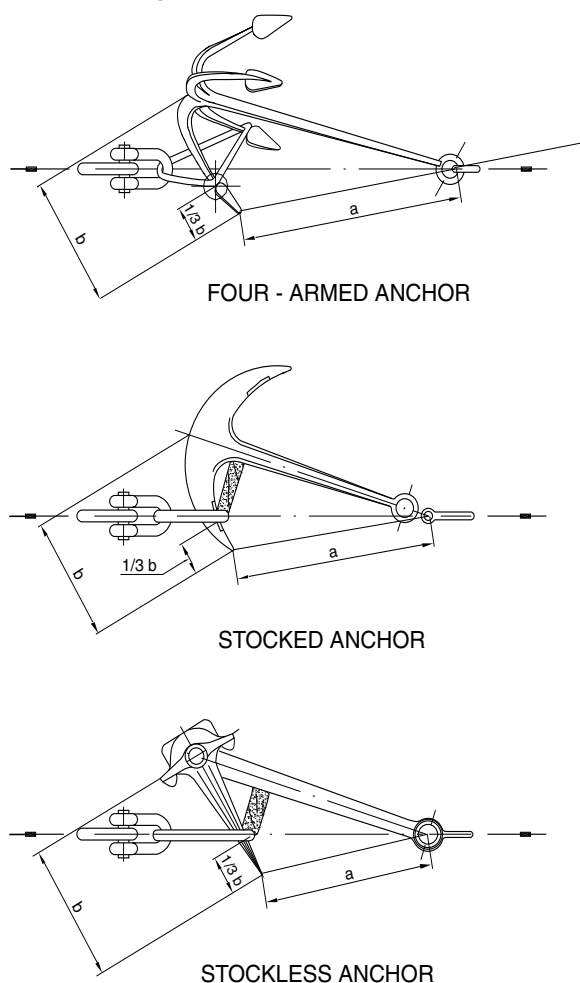

1.6.3 Examinations after proof load testing

After proof load testing, in addition to the examinations intended to ascertain the absence of cracks, fractures, permanent deformations etc, anchors made in more than one piece are to be examined for free rotation of their heads over the complete angle.

Cast steel VHHP anchors are to be inspected by ultrasonic examination in way of areas where feeder heads and risers have been removed and where weld repairs have been carried out.

Welded steel VHHP anchors are to be inspected in way of the welded joints. In way of highly stressed or suspect areas, *Tasneef* may require ultrasonic or radiographic examination.

Additional tests (e.g. hammering test and drop test) of VHHP anchors may be considered by *Tasneef* on a case-by-case basis.

1.6.4 Testing machines

Testing machines are to be in accordance with requirements specified in Ch 1, Sec 2, [1.2.1].

1.7 Identification, marking, certification

1.7.1 The Manufacturer is to adopt a system of identification which will enable all finished anchors to be traced to the original materials and their manufacturing.

Anchors which have been tested and inspected with satisfactory results are to be marked with the following details:

- Tasneef* brand
- file number and code of the local inspection office
- date of test and reference to the testing documentation
- cast number or other marking which will enable the history of the fabrication of the material to be traced
- mass of the anchor (excluding the mass of the stock, if any, which is in any event to be stamped on the stock itself)
- the letters HHP or VHHP for high holding power or very high holding power anchors, respectively
- personal stamp of the Surveyor responsible for inspection (optional).

In addition to the above marking, each part of the anchors manufactured by casting or forging is to be marked by the Manufacturer with the words "cast steel" or "forged steel", respectively.

All the required marking is to be stamped on one side of the anchor reserved for this purpose; in the case of anchors made of more than one piece, such marking is to be stamped both on the shank and on one of the arms.

1.7.2 The testing documentation indicated in Ch 1, Sec 1, [4.2.1] is required and is to include all the information, as appropriate.

2 Stud link chain cables and accessories

2.1 Application

2.1.1 General

The requirements of this Article apply to the materials, design, manufacture and testing of stud link anchor chain cables and accessories used for yachts.

2.2 Chain cable grades

2.2.1 Depending on the nominal tensile strength of the steel used for manufacture and on the type of manufacture, stud link chain cables are to be divided into the following grades:

- Q1a for flash welding - ordinary steel
- Q2a for flash welding and drop forging - high tensile steel
- Q2b for casting - high tensile steel
- Q3a for flash welding and drop forging - very high tensile steel
- Q3b for casting - very high tensile steel.

2.3 Approval of chain cable Manufacturers

2.3.1 Anchor chain cables and accessories are to be manufactured by works approved by *Tasneef* approval tests are required.

Applications for approval are to provide detailed information about the production works and fabricated chains such

as the method of manufacture, the grade of materials, the links' nominal dimensions, etc.

Where materials with chemical composition or properties other than those given in Tab 2 and Tab 3 are proposed, their acceptance is at Tasneef discretion. The same applies in the case of design of links different from [2.9.2].

2.4 Steels for chain cables

2.4.1 General

These requirements apply to rolled steels, forgings and castings used for the manufacture of anchor chain cables and accessories.

2.4.2 Requirements for material Manufacturers

All materials used for the manufacture of anchor chain cables and accessories are to be supplied by Manufacturers approved by Tasneef Approval is not required for Grade Q1 steel bars.

Material suppliers of Grade Q3 chain cable Manufacturers are to submit specifications of the materials used. These specifications are to contain all necessary details, such as manufacturing procedure, deoxydation practice, specified chemical composition, heat treatment and mechanical properties.

2.5 Rolled steel bars

2.5.1 Supply condition

Unless otherwise stipulated (i.e. heat treatment), the steel bars are supplied in the as-rolled condition.

The steel bars are to be supplied with a works' certificate indicating the chemical composition and the delivery condition.

2.5.2 Chemical composition

The chemical composition of steel bars is generally to be within the limits given in Tab 2.

2.5.3 Sampling for mechanical tests

For performance of mechanical tests, steel bars are to be sorted according to heats and diameters into batches not exceeding 50 t each. A test sample is to be taken from each batch for tensile tests and, when required depending on the grade, for impact tests. Prior to sampling, the test samples are to be subjected to the heat treatment provided for the finished chain cables; see Tab 5. Details of the heat treatment are to be provided by the chain cable Manufacturer.

The tensile and Charpy V-notch impact test specimens are to be taken from the test sample in the longitudinal direction at a distance of 1/6 diameter from the surface or as close as possible to this position (see Fig 2).

For the tensile test, one specimen is to be taken from each batch.

One set of longitudinal Charpy V-notch test specimens shall be taken from each test unit and tested at the temperature prescribed in Tab 3. The specimen transverse axis is to be radial to the steel bar. The average value obtained from one set of three impacts specimens is to comply with the requirements given in Tab 3. One individual value only may be below the specified average value provided it is not less than 70% of that value.

2.5.4 Tests

Mechanical tests representing the steell bars are normally to be carried out by the steel mill and the results are to meet the requirements of Tab 3; however, Tasneef may allow mechanical testing on bars to be performed by the chain cable Manufacturer. Test coupons are to be in a heat treated condition equivalent to that of the finished chain cables and accessories.

A tensile test and, depending on the grade, an impact test (on three specimens) are required for each test sample. The mechanical tests are to be carried out in the presence of the Surveyor.

The test results are to be in agreement with the mechanical properties specified in Tab 3.

Table 2 : Chemical composition of rolled steel bars

Grade	Chemical composition in maximum percent, unless specified					
	C (%)	Si (%)	Mn (%)	P (%)	S (%)	Al tot (%) min. (1)
Q1a	0,20	0,15 - 0,35	min. 0,40	0,040	0,040	NR
Q2a (2)	0,24	0,15 - 0,55	max. 1,60	0,035	0,035	0,020
Q3a (3)	In accordance with an approved specification					
(1) Aluminium may be replaced partly by other grain refining elements.						
(2) Subject to the agreement of Tasneef additional alloying elements may be added.						
(3) To be killed and fine grain.						
NR = Not required.						

Table 3 : Mechanical properties of rolled steel bars

Grade	R _{eH} (N/mm ²) min	R _m (N/mm ²)	A ₅ (%) min	Z (%) min	Charpy V-notch impact test	
					Test temp. (°C)	Absorbed energy in Joules, min.
Q1a	NR	370 - 490	25	NR	NR	NR
Q2a	295	490 - 690	22	NR	0	27 (1)
Q3a	410	min 690	17	40	0 (2)	60
					-20	35

(1) The impact test of grade 2 materials may be waived if the chain cable is supplied in a heat treated condition as per Tab 6.
(2) Testing is normally to be carried out at 0° C.

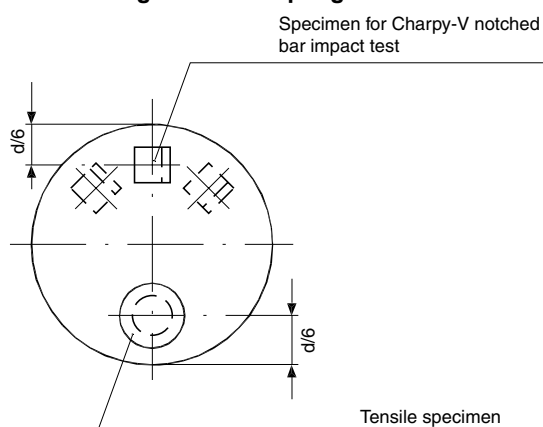
Figure 2 : Sampling locations**2.5.5 Re-tests**

If the tensile test requirements are not fulfilled, a re-test of two further specimens selected from the same sample is permissible. Failure to meet the specified requirements in either or both additional tests will result in rejection of the batch represented unless it is clearly attributable to improper simulated heat treatment.

If the Charpy V-notch impact test requirements are not fulfilled, a re-test of three further specimens selected from the same sample is permissible. The results are to be added to those previously obtained to form a new average. The new average is to comply with the requirements. No more than two individual results are to be lower than the required average and no more than one result is to be below 70% of the specified average value. Failure to meet the requirements results in rejection of the batch represented unless it can be clearly attributable to improper simulated heat treatment.

If failure to pass the tensile test or the Charpy V-notch impact test is definitely attributable to improper heat treatment of the test sample, a new test sample may be taken from the same piece and reheat treated. The complete test (both tensile and impact tests) is to be repeated; and the original results obtained may be disregarded.

2.5.6 Freedom from defects

All products are to be checked by Manufacturers in relation to their surface conditions.

The materials are to be free from internal and surface defects which might impair proper workability and use. Sur-

face defects may be repaired by grinding, provided the permissible tolerance is not exceeded.

2.5.7 Dimensional check - tolerances

The diameter and roundness are to be within the tolerances specified in Tab 4, unless otherwise agreed.

Table 4 : Dimensional tolerances of rolled steel bars

Nominal diameter (mm)	Tolerance on diameter (mm)	Tolerance on roundness $d_{max} - d_{min}$ (mm)
less than 25	-0 +1,0	0,60
25 - 35	-0 +1,2	0,80
36 - 50	-0 +1,6	1,10
51 - 80	-0 +2,0	1,50
81 - 100	-0 +2,6	1,95
101 - 120	-0 +3,0	2,25
121 - 160	-0 +4,0	3,00

2.5.8 Identification of material

Manufacturers are to effectively operate an identification system ensuring traceability of the material to the original cast.

2.5.9 Marking

The minimum markings required for the steel bars are the steelmaker's brand mark, the steel grade and an abbreviated symbol of the heat. Steel bars having diameters up to and including 40mm, and combined into bundles, may be marked on permanently affixed labels.

2.5.10 Material certification

Bar material for Grade Q2a or Grade Q3a is to be certified by Tasneef. For each consignment, the steelmaker is to provide the Surveyor with a certificate containing at least the following data:

- steel maker's name and/or purchaser's order no.
- number and dimensions of bars and weight of consignment
- steel specification and chain grade
- heat number
- manufacturing procedure
- chemical composition

- details of heat treatment of the test sample (where applicable)
- results of mechanical tests (where applicable)
- number of test specimens (where applicable).

2.6 Forged steels for chain cables and accessories

2.6.1 General requirements

Forged steels used for the manufacture of chain cables and accessories are to be in compliance with Ch 2, Sec 3, unless otherwise specified in the following requirements.

2.6.2 Chemical composition

The chemical composition is to comply with the specification approved by Tasneef. The steel Manufacturer is to determine and certify the chemical composition of every heat of materials.

2.6.3 Heat treatment

The stock material may be supplied in the as-rolled condition. Finished forgings are to be properly heat treated, i.e. normalised or quenched and tempered, whichever is specified for the relevant steel grade.

2.7 Cast steels for chain cables and accessories

2.7.1 General requirements

Cast steels used for the manufacture of chain cables and accessories are to be in compliance with Ch 2, Sec 4, unless otherwise specified in the following requirements.

2.7.2 Chemical composition

The chemical composition is to comply with the specification approved by Tasneef. The foundry is to determine and certify the chemical composition of every heat.

2.7.3 Heat treatment

All castings are to be properly heat treated, i.e. normalised, normalised and tempered or quenched and tempered, whichever is specified for the relevant cast steel grade.

2.8 Materials for studs

2.8.1 The studs are to be made of steel corresponding to that of the chain cable or from rolled, cast or forged ordinary steel, as indicated in the chain specification; grey or nodular cast iron is not permitted.

Figure 3 : Typical design of chain links

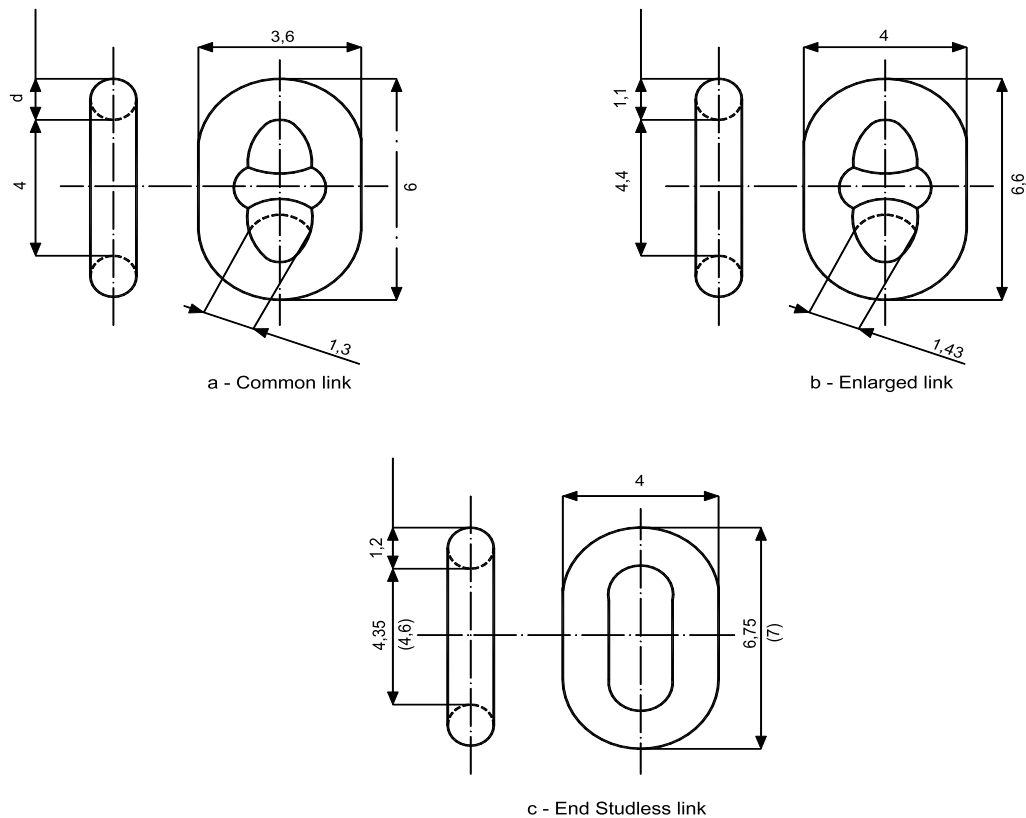

All dimensions are shown as multiples of the nominal diameter d of the common link.

The dimensions in brackets may be chosen for end studless links in outboard end swivel pieces.

Figure 4 : Typical design of shackles and swivels

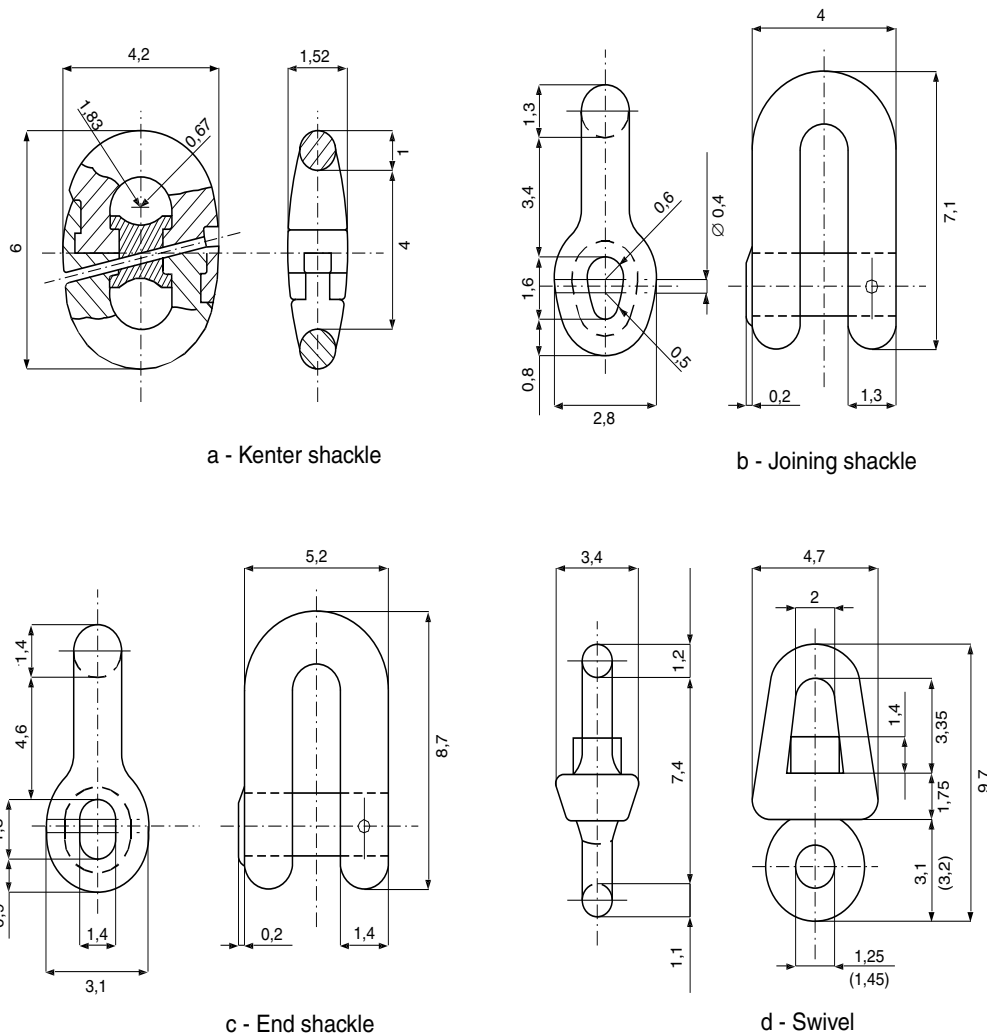

All dimensions are shown as multiples of the nominal diameter d of the common link. For swivels, dimensions in brackets may apply to cast steel swivels.

2.9 Design and manufacture

2.9.1 Manufacturing process

Stud link chain cables are preferably to be manufactured by flash welding using grade Q1, Q2 or Q3 steel bars. Manufacture of the links by drop forging or steel casting is permitted.

Accessories such as shackles, swivels and swivel shackles are to be forged or cast in steel of at least Grade 2. The welded construction of these parts may also be approved.

2.9.2 Design

Chain cables are to be designed according to a standard recognised by *Tasneef* such as ISO 1704. Typical designs are given in Fig 3 and Fig 4. Where designs do not comply with these figures and where accessories are of welded construction, drawings giving full details of the design, the manufacturing process and the heat treatment are to be submitted to *Tasneef* for approval.

A length of chain cable is to comprise an odd number of links.

2.9.3 Heat treatment

According to the grade of steel, chain cables and accessories are to be supplied in one of the conditions specified in Tab 5. The heat treatment is to be performed before the proof load test, the breaking load test, and all mechanical testing.

Table 5 : Condition of supply of chain cables and accessories

Grade	Chain cables	Accessories
Q1	As-welded or normalised	NA
Q2	As welded or normalised (1)	Normalised
Q3	Normalised, Normalised and tempered or quenched and tempered	Normalised, Normalised and tempered or quenched and tempered
(1) Grade Q2 chain cables made by forging or casting are to be supplied in the normalised condition. NA = Not applicable.		

2.9.4 Mechanical properties

The mechanical properties of finished chain cables and accessories are to be in accordance with Tab 7.

2.9.5 Proof and breaking load properties

Chain cables and accessories are to withstand the proof and breaking loads indicated in Tab 8, depending on the relevant chain cable grade.

2.9.6 Freedom from defects

All individual parts are to have a clean surface consistent with the method of manufacture and be free from cracks, notches, inclusions and other defects impairing the performance of the product. The flashes produced by upsetting or drop forging are to be properly removed.

Minor surface defects may be ground off so as to leave a gentle transition to the surrounding surface. Remote from the crown, local grinding up to 5% of the nominal link diameter may be permitted.

2.9.7 Dimensions and dimensional tolerances

The shape and proportions of links and accessories are to conform to a recognised standard (see Fig 3 and Fig 4) such as ISO 1704 or the designs specially approved.

The permissible tolerances applicable to links are the following :

- a) Diameter measured at the crown (two measurements are to be taken at the same location: one in the plane of the link (see d_p in Fig 3, and one perpendicular to the plane of the link):
 - up to 40 mm nominal diameter: -1mm
 - over 40 up to 84 mm nominal diameter: -2 mm
 - over 84 up to 122 mm nominal diameter: -3 mm
 - over 122 mm nominal diameter: -4 mm
 - the plus tolerance may be up to 5% of the nominal diameter.
- b) Diameter measured at locations other than the crown:

The diameter is to have no negative tolerance. The plus tolerance may be up to 5% of the nominal diameter. The approved Manufacturer's specification is applicable to the plus tolerance of the diameter at the flush-butt weld.
- c) The maximum allowable tolerance on assembly measured over a length of 5 links may equal +2,5%, but may not be negative (tolerance measured with the chain under tension after proof load test, which means chain loaded to about 10% of the proof load or stretched to full inter-link contact).
- d) All other dimensions are subject to a manufacturing tolerance of $\pm 2,5\%$, provided always that all parts of the chain cable fit together properly.
- e) Studs are to be located in the links centrally and at right angles to the sides of the link, although the studs of the final link at each end of any length may also be located off-centre to facilitate the insertion of the joining shackle.

The following tolerances are regarded as being inherent in the method of manufacture and are not to be

objected to, provided that the stud fits snugly and its ends lie practically flush against the inside of the link.

Maximum off-centre distance "X": 10% of the nominal diameter d ,

Maximum deviation " α " from the 90°- position: 4°.

The tolerances are to be measured in accordance with Fig 5.

The following tolerances are applicable to accessories:

- nominal diameter : +5%, -0%
- other dimensions : $\pm 2,5\%$.

Figure 5 : Manufacturing tolerances

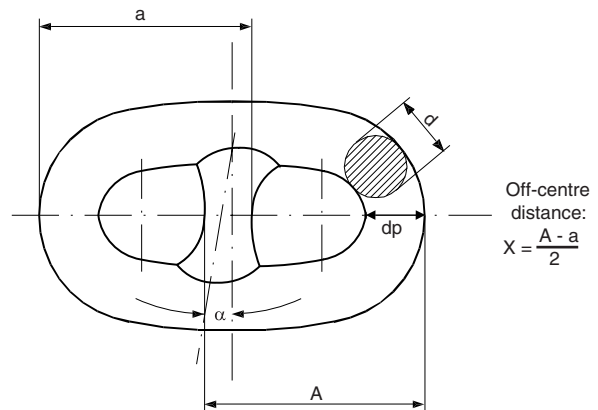

2.9.8 Welding of studs

For all grades of stud link anchor chain cables, it is possible to secure studs on the links by welding.

The welding of chain studs is to be in accordance with an approved procedure subject to the following conditions:

- a) the studs are to be of weldable steel (see [2.8])
- b) the studs are to be welded at one end only, i.e., opposite to the weldment of the link. The stud ends are to fit the inside of the link without appreciable gap
- c) the welds, preferably in the horizontal position, are to be executed by qualified welders using suitable welding consumables
- d) all welds are to be carried out before the final heat treatment of the chain cable
- e) the welds are to be free from defects liable to impair the proper use of the chain. Under-cuts, end craters and similar defects are, where necessary, to be ground off.

Tasneef reserves the right to require a procedure test for the welding of chain studs.

2.10 Testing of finished chain cables

2.10.1 Proof and breaking load tests

- a) Finished chain cables are to be subjected to the proof load test and the breaking load test, in the presence of the Surveyor and are not to fracture or exhibit cracking. Special attention is to be given to the visual inspection of the flash-butt weld, if present. For this purpose, the chain cables are to be free from paint and anti-corrosion media.

- b) Each chain cable length (27,5 m) is to be subjected to a loading test at the proof load appropriate to the particular chain cable as given by Tab 8 using an approved testing machine.
- c) For the breaking load test, one sample comprising at least three links is to be taken from every four lengths or fraction of chain cables and tested at the breaking loads given by Tab 8. The breaking load is to be maintained for a minimum of 30 seconds. The links concerned are to be made in a single manufacturing cycle together with the chain cable and are to be welded and heat treated together with it. Only after this may they be separated from the chain cable in the presence of the Surveyor.
- d) If the tensile loading capacity of the testing machine is insufficient to apply the breaking load for chain cables of large diameter, another equivalent testing method is to be agreed with Tasneef

2.10.2 Re-tests

- a) Should a breaking load test fail, a further sample may be taken from the same length of chain cable and tested. The test will be considered successful if the requirements are then satisfied.
If the retest fails, the length of chain cable concerned is rejected. If the Manufacturer so wishes, the remaining three lengths belonging to the batch may then be individually subjected to testing at the breaking load. If one such test fails to meet the requirements, the entire batch is rejected.
- b) Should a proof load test fail, the defective link(s) is (are) to be replaced, a local heat treatment to be carried out on the new link(s) and the proof load test is to be repeated. In addition, an investigation is to be made to identify the cause of the failure and Tasneef then decides on further action.

2.10.3 Mechanical tests on grade Q2 and Q3 chain cables

For grade Q2a and Q3a chain cables, mechanical test specimens required in Tab 6 are to be taken from every four

lengths as hereunder specified. For forged or cast chain cables where the batch size is less than four lengths, the sampling frequency will be by heat and heat treatment charge. Mechanical tests are to be carried out in the presence of the Surveyor. For the location of the test specimens see [2.5.3] and Fig 2. Testing is to be in accordance with [2.5.3]. Retesting is to be in accordance with [2.5.5].

An additional link (or, where the links are small, several additional links) is (are) to be provided in a length of chain cable not containing the specimen for the breaking test. The specimen link(s) is (are) to be manufactured and heat treated together with the length of chain cable.

The mechanical properties and the impact energy are to be in accordance with the values indicated in Tab 7.

2.10.4 Marking

Chain cables which meet the requirements are to be stamped at both ends of each length at least with the following marks, as indicated in Fig 6:

- chain cable grade
- certificate number
- Tasneef stamp.

Figure 6 : Marking of chain cables

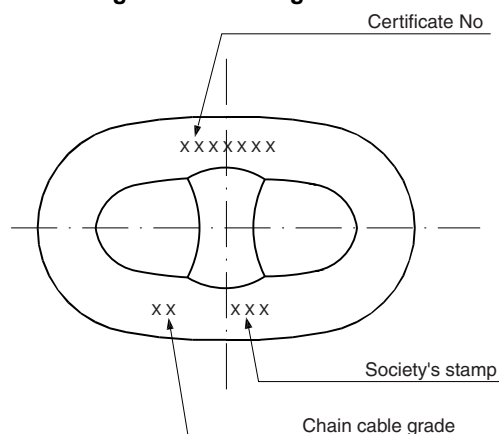

Table 6 : Number of mechanical test specimens for finished chain cables and accessories

Grade	Manufacturing method	Condition of supply (1)	Number of tests on every four lengths		
			Tensile test for base material	Charpy V-notch impact test	
				base material	weldment
Q1a	Flush-butt welded	AW,N	NR	NR	NR
Q2a	Flush-butt welded	AW	1	3	3
		N	NR	NR	NR
Q3a	Flush-butt welded	N, N+T, Q+T	1	3	3
Q2a, Q2b	cast or drop forged	N	1	3 (2)	NA
Q3a, Q3b	cast or drop forged	N, N+T, Q+T	1	3	NA

(1) AW = as welded; N = Normalised; N+T = Normalised and tempered; Q+T = Quenched and tempered.

(2) [2.10.1] For chain cables, Charpy V-notch impact test is not required.

NR = Not required

NA = Not applicable

Table 7 : Mechanical properties of finished chain cables and accessories

Grade	R _{eH} N/mm ² min	R _m N/mm ²	A ₅ % min	Z % min	Charpy V-notch impact test		
					Test temperature in (°C)	Absorbed energy (J) min.	
						Base metal	Weldment
Q1	NR	NR	NR	NR	NR	NR	
Q2a, Q2b	295	490-690	22	NR	27	27	
Q3a, Q3b	410	690 min	17	40	0 (1)	60	
					-20	35	27

(1) Testing is normally to be carried out at 0 °C.
NR = Not required.

Table 8 : Formulae for proof load and breaking load tests

Test	Grade 1	Grade 2	Grade 3
Proof load (kN)	0,00686d ² (44-0,08d)	0,00981d ² (44-0,08d)	0,01373d ² (44-0,08d)
Breaking load (kN)	0,00981d ² (44-0,08d)	0,01373d ² (44-0,08d)	0,01961d ² (44-0,08d)

Note 1: d = nominal diameter, in mm.

2.10.5 Certification

Chain cables which meet the requirements are to be certified by ^{Tasneef} at least with the following items:

- Manufacturer's name
- grade
- chemical composition (including total aluminum content)
- nominal diameter/weight
- proof/break loads
- heat treatment
- marks applied to chain
- length
- mechanical properties, where applicable.

2.11 Testing of accessories

2.11.1 Proof load test

All accessories are to be subjected to the proof load test at the proof load specified for the corresponding chain in given by Tab 8, and in accordance with the provisions of [2.10.1], as appropriate.

2.11.2 Breaking load test

From each manufacturing batch (same accessory type, grade, size and heat treatment charge, but not necessarily representative of each heat of steel or individual purchase order) of 25 units or less of detachable links, shackles, swivels, swivel shackles, enlarged links and end links, and from each manufacturing batch of 50 units or less of kenter shackles, one unit is to be subjected to the breaking load test at the break load specified for the corresponding chain given by Table 8 and in accordance with the provisions of [2.10.1], as appropriate. Parts tested in this way may not be put to further use. Enlarged links and end links need not be tested provided that they are manufactured and heat treated together with the chain cable.

^{Tasneef} may waive the breaking load test if:

- the breaking load has been demonstrated during the approval testing of parts of the same design,
- the mechanical properties, of each manufacturing batch are proved, and
- the parts are subjected to suitable non-destructive testing.

Notwithstanding the above, the accessories, which have been successfully tested at the prescribed breaking load appropriate to the chain, may be used in service, on a case by case basis, where the accessories are manufactured with the following:

- the material having higher strength characteristics than those specified for the part in question (e.g. grade Q3 materials for accessories for grade Q2 chain)
- or, alternatively, the same grade material as the chain but with increased dimensions subject to the successful procedure test that such accessories are so designed that the breaking strength is not less than 1,4 times the prescribed breaking load of the chain for which they are intended.

2.11.3 Mechanical properties and tests

Unless otherwise specified, the forging or casting is at least to comply with the mechanical properties given in Tab 7, when properly heat treated. For test sampling, forgings or castings of similar dimensions originating from the same heat treatment charge and the same heat of steel are to be combined into one test unit.

Mechanical tests as described in [2.10] are to be carried out in the presence of the Surveyor, depending on the type and grade of material used.

From each test unit, one tensile test specimen and three Charpy V-notch impact test specimens are to be taken in accordance with Tab 6. For the location of the test specimens see [2.5.3] and Fig 2. Testing is to be in accordance with [2.5.4] and retesting is to be in accordance with [2.5.5]. Enlarged links and end links need not be tested pro-

vided that they are manufactured and heat treated together with the chain cable.

The toughness of anchor shackles for very high holding power anchors is to be such that the average energy of the Charpy V-notch impact test is not less than the value specified in [2.10.3] for grade Q3 anchor chain cables.

2.11.4 Marking

Accessories which meet the requirements are to be stamped as follows:

- chain cable grade
- certificate number
- Tasneef stamp.

2.11.5 Certification

Chain accessories which meet the requirements are to be certified by Tasneef at least with the following items:

- Manufacturer's name
- grade
- heat Number
- chemical composition (including total aluminum content)
- nominal diameter/weight
- proof/break loads
- heat treatment
- marks applied to accessory
- mechanical properties, where applicable.

3 Studless chain cables

3.1 Application

3.1.1 General

The requirements of this Article apply to the materials and testing of studless chain cables.

3.1.2 Manufacture

The requirements of [2.3.1] are to be complied with.

On request, pressure butt welding may also be approved for studless, grade 1 and 2 chain cables, provided that the nominal diameter of the chain cable does not exceed 26mm.

3.1.3 Studless chain cable grades

Depending on the nominal tensile strength of the steel used for manufacture, studless chain cables are divided into the following grades:

- SL1, SL2 and SL3 for steels in compliance with requirements for stud link steel grades Q1, Q2 and Q3, respectively.

3.1.4 Short and long links

The provisions of this Article apply to short studless link chain cables.

When long studless link chain cables are intended to be used, the steel properties are to be submitted by the Manufacturer. The tensile strength and yield stress minimum values are to be specially adapted for each grade, so that the chain cable can withstand the proof and breaking loads

indicated in Tab 9 depending on the relevant chain cable grade.

As a rule, the use of long links is not permitted for SL3 studless chain cables.

3.2 Materials for studless chain cables

3.2.1 Requirements for materials

The general requirements concerning material Manufacturers, manufacturing procedure, supply condition, freedom from defects and dimensional tolerances are the same as those given in [2.4.2], [2.5.1], [2.5.6] and [2.5.7] for stud link chain cables.

The chemical composition and mechanical properties of steels to be used for manufacturing chains of grades SL1, SL2 and SL3 are to comply with the prescriptions given in Tab 3 (mechanical properties) and Tab 2 (chemical composition) for grades Q1, Q2 and Q3, respectively.

For SL3 chain cables, the minimum tensile requirements may be reduced down to 365 N/mm² (instead of 410 N/mm²) for yield stress and 610 N/mm² (instead of 690 N/mm²) for tensile strength on condition that the finished chain can withstand the required proof and breaking loads.

3.2.2 Testing of materials

The requirements for testing of material for studless chain cables of grades SL1, SL2 and SL3 are the same as for testing of the corresponding grades Q1, Q2 and Q3, given in [2.5.4].

However, for grades SL1 and SL2, material testing in the presence of the Surveyor is not required, and the supply of a works' certificate may be admitted on condition that all the bars can be identified with the corresponding certificate.

3.3 Testing of finished chain cables

3.3.1 General

Studless chain cables and corresponding accessories are to withstand the proof and breaking loads indicated in Tab 9, depending on the relevant studless chain cable grade.

Mechanical testing on links is required for grade SL3 only.

3.3.2 Proof load test

All finished studless chain cables are to be subjected, over their full length, to a loading test at the proof load appropriate to the particular chain as shown in Tab 9. For the load test, an approved testing machine is to be used.

Re-tests are to be conducted as indicated in [2.10.2] b) for stud link chain cables.

3.3.3 Breaking load tests

Sample lengths, comprised of at least three links and taken every four 27,5 m lengths or every 110 m from the chain cables, are to be tested at the breaking loads shown in Tab 9.

The conditions for execution and separation of the three link samples are the same as those prescribed in [2.10.1] c).

Re-tests are to be conducted as indicated in [2.10.2] a) for stud link chain cables.

Table 9 : Proof and breaking loads for studless chain cables

Chain cable diameter (mm)	Grade SL1		Grade SL2		Grade SL3		Mass of 100 m of chain	
	Proof load (kN)	Breaking load (kN)	Proof load (kN)	Breaking load (kN)	Proof load (kN)	Breaking load (kN)	Normal link (kg)	Short link (kg)
6,0	6,5	13	9	18	13	26	79	86
8,0	12,0	24	17	34	24	48	141	153
10,0	18,5	37	26	52	37	74	240	240
11,0	22,5	45	32	64	45	90	265	289
12,5	29,0	58	41	82	58	116	345	375
14,5	39,0	78	55	110	78	156	462	503
16,0	47,5	95	67	134	95	190	563	612
17,5	56,5	113	80	160	113	226	675	732
19,0	67,0	134	95	190	134	268	794	865
20,5	78,0	156	111	222	156	312	928	1005
22,0	90,0	180	128	256	180	360	1063	1155
24,0	106	212	151	302	212	424	1268	1380
25,5	120	240	170	340	240	480	1432	1560
27,0	135	270	192	384	270	540	1610	1742
28,5	150	300	213	426	300	600	1788	1942
30,0	166	332	236	472	332	664	1984	2155
32,0	189	378	268	536	378	756	2255	2480
33,0	201	402	285	570	402	804	2396	2605
35,0	226	452	321	642	452	904	2705	2940
37,0	253	506	359	718	506	1012	3020	3380
38,0	267	534	379	758	534	1068	3200	3460
40,0	296	592	420	840	592	1184	3520	3830

3.3.4 Mechanical tests on grade SL3 studless chain cables

For grade SL3, tensile tests and Charpy V-notch tests are to be performed as required for Q3 stud link chain cables (see [2.10.3]).

The values to be obtained are:

- tensile properties: the same values as required for the round bars used to manufacture the chain cables
- Charpy V-notch impact tests: the same as prescribed in Tab 7 for Q3 stud link chain cables.

No mechanical tests are required on links with a nominal diameter under 20 mm.

3.3.5 Dimensions and tolerances

The dimensions of links are to comply with a recognised standard. Typical design of a studless link is given in Fig 7.

The tolerances are the same as those prescribed in [2.9.7] for stud link chain cables.

3.3.6 Galvanising in manufacture

When galvanising is required, this is to be made by the hot process, following the standard ISO 1461.

The average mass of the coating (for chains above 5 mm in diameter) is not to be under 500 g/m². The tolerances given in [3.3.5] are to be maintained after the galvanising operations.

The required proof and breaking load tests are to be carried out after the galvanising is completed.

Figure 7 : Studless link for studless chain cable

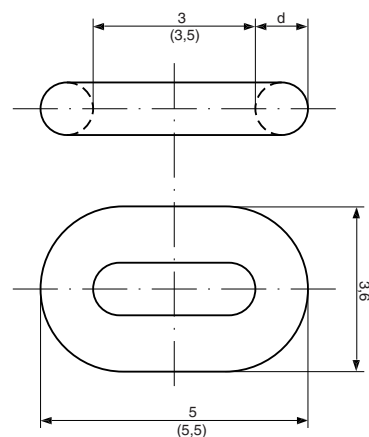

All dimensions are shown as multiples of the nominal diameter d. The dimensions in brackets correspond to long link chain cables.

3.3.7 Marking

Studless chain cables which meet the requirements are to be stamped at both ends of each length as indicated in [2.10.4] for stud link chain cables.

4 Steel wire ropes

4.1 Application

4.1.1 General

The requirements of this Article apply to unalloyed steel wire ropes, round stranded, intended for warping, towing, rigging and similar applications.

4.1.2 Continuous production

In the case of continuous production, a specific procedure for testing and inspection may be allowed by the Tasneef for approved Manufacturers at their request.

4.2 Manufacture

4.2.1 General

Wire ropes are to be manufactured in accordance with national or international standards recognised by Tasneef. In particular, ISO 2408 Standard is recognised.

The type and size of ropes are to be in accordance with the requirements specified for each application by the relevant part of the Rules or the approved plans relative to each installation.

Ropes of type and size different from those covered by this Article are considered in each case, taking into account their application; see also [4.2.4].

4.2.2 Rope materials

Ropes are to be manufactured with wires drawn from steel billets of appropriate and homogeneous quality; the steel is to be made by a process in accordance with Ch 1, Sec 2, [1.2].

Wires are not to show signs of defects and their surface is to be smooth and regular.

All the steel wires of a wire rope are to be of the same tensile grade, generally including those forming the metal core, if any.

As a rule, wires having the minimum nominal tensile strength R_m in the range 1420 - 1960 N/mm² are to be used.

The fibre core of the ropes or of the strands may be made of natural fibres (manilla, abaca, sisal, hemp, jute, cotton) or of synthetic fibres (polyethylene, polypropylene, polyamid, polyester).

4.2.3 Galvanising

All types of wire ropes are to be zinc-coated, except in special cases to be considered individually by Tasneef and gener-

ally involving limitation in the use of the wire ropes concerned.

Galvanising procedures and their results (in particular, degree of bonding and uniformity of the coating) are to be suitable and to the satisfaction of Tasneef

The wires are to be galvanised so that the zinc mass satisfies the values specified in Tab 10.

Table 10 : Galvanising of the wires of wire ropes

Diameter d of galvanised wires (mm)	Minimum mass of zinc coating (g/m ²)	
	Class A	Class B
$0,45 \leq d < 0,50$	75	40
$0,50 \leq d < 0,60$	90	50
$0,60 \leq d < 0,80$	110	60
$0,80 \leq d < 1,00$	130	70
$1,00 \leq d < 1,20$	150	80
$1,20 \leq d < 1,50$	165	90
$1,50 \leq d < 1,90$	180	100
$1,90 \leq d < 2,50$	205	110
$2,50 \leq d < 3,20$	230	125
$3,20 \leq d < 4,00$	250	135

4.2.4 Manufacturing process and facilities

The manufacturing procedures and relevant facilities are to be suitable and such as to ensure production of the required quality. The manufacturing procedures of ropes having wire with nominal tensile strength equal to or greater than 1960 N/mm² and ropes of different construction are to be approved for the individual Manufacturers in accordance with the requirements of the document "Approval of Manufacturers".

The required tests and examinations are to be performed with the appropriate equipment and procedures recognised by Tasneef the testing machine is to be calibrated.

4.2.5 Quality of materials

Ropes are to be free from material or manufacturing defects which might impair their intended application, their efficiency, or their expected life span; in particular, they are to be free from oxidising or corrosion traces and there is to be no sign of broken wires, scratching, crushing or defective twisting.

4.2.6 Dimensional tolerances

Unless otherwise specified, the tolerances on the diameter given in recognised standards such as ISO 2408 apply; in

particular, for the ropes considered in these Rules, the tolerances on the diameter are specified in Tab 11.

Table 11 : Permissible tolerances on nominal diameter

Nominal diameter of rope (mm)	Tolerance on the nominal diameter (%)	
	Ropes having strands with fibre core	Ropes having strands with metal core
< 8	+7 ; -1	+5 ; -1
≥ 8	+6 ; -1	+4 ; -1

4.3 Types of ropes

4.3.1 General

The wire ropes consist of an assembly of several strands (as a rule, at least six and a maximum of eight, except for non-rotating ropes) laid around a fibre or metal core.

Each strand is to include at least seven wires. In the case of a fibre core, the strands are to include at least two layers of wires.

The following types of ropes are the most commonly used:

- a) ropes with 6 equal strands around a fibre core; each strand may include either 7, 19 or 37 steel wires (total number of wires: 42, 114 or 222); see Tab 12
- b) ropes with 6 equal strands around a fibre core; each strand includes a fibre core and 24 steel wires (total number of wires: 144 plus 6 fibre cores); see Tab 13
- c) Warrington 6x19 ropes with 6 equal strands around a fibre core; each strand includes 19 steel wires (total number of wires: 114); see Tab 14
- d) Warrington-Seale 6xn ropes with 6 equal strands around a fibre core; each strand includes n = 26, 31, 36 or 41 steel wires; see Tab 14.

Other types of ropes which may be used depending on the applications are also indicated in Tab 12 to Tab 16.

4.3.2 Main characteristics

The typical characteristics of the ropes are generally the following:

- diameter (of the circumference enclosing a cross-section of the rope; to be measured with the rope strained under a load of approximately 1/20 of its minimum breaking strength)
- construction (number and type of the cores, strands and wires)
- coating or type of surface finish of the steel wires
- breaking load.

As regards the ropes considered by the Rules, the following applies to the above characteristics:

- the wire coating is to be of zinc in all cases

- the minimum breaking loads applicable when testing full sections of ropes are given in Tab 12 to Tab 16 for each type of rope in relation to its diameter.

4.4 Sampling and testing

4.4.1 Sampling

Acceptance tests are to be performed on each rope length (defined as either one single length or multiple lengths manufactured with continuity).

Where the rope length is greater than 10000 m, the acceptance tests are to be carried out for every portion of 10000 m or fraction thereof.

When the base material used has the same origin and characteristics, the acceptance tests required in [4.4] for each rope length may be performed for each rope construction and diameter.

Suitable sampling and identification procedures are to be adopted, to the Surveyor's satisfaction.

The tests and examinations under [4.4.2], [4.4.3] or [4.4.4], [4.4.6] and [4.4.8] are to be performed for acceptance.

The tests under [4.4.5] and [4.4.7] are to be carried out when specified in the order or required by the Surveyor as a production check.

4.4.2 Visual examination and check of the diameter and construction

The examination and checks are to be performed by the Manufacturer and random checks are to be carried out by the Surveyor to the extent deemed necessary.

4.4.3 Breaking test on full size specimens

Samples and testing procedures are to be in compliance with recognised standards, such as ISO 3108.

The test sample is to be long enough to obtain a clear distance, between the grips of the testing machine, at least equal to 30 times the diameter of the ropes, with a minimum of 600 mm.



The above clear distance may be reduced to 300 mm if the diameter is less than 6 mm.

During the test, when the applied load has exceeded approximately 80% of the required breaking load, the load is to be applied slowly and steadily (about 10 N/mm² per second).

The breaking load is to be not less than the minimum value required in Tab 12 to Tab 16 for each type and diameter of rope.

The result of the test may be disregarded if the specimen breaks outside the gauge length, in particular in way of the terminals.

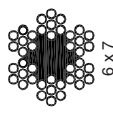
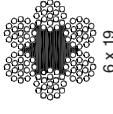
Table 12 : Minimum breaking loads, in kN, of steel wire ropes with fibre core (non-parallel lay ropes with 6 ordinary strands)

Composition of wire rope	 1 + 6		 1 + 6 + 12		 1 + 6 + 12 + 18			
	Ordinary							
	Tensile grade		Tensile grade		Tensile grade			
Diameter of rope (mm)	1420	1570	1770	1960	1420	1570	1770	1960
10					42,9	47,4	53,5	59,2
11				61,2	51,9	57,4	64,7	71,6
12				74,0	61,8	68,3	77,0	85,2
13				88,1	72,5	80,1	90,3	100
14				103	84,1	92,9	105	116
16	121	134	150	167	110	121	137	152
18	153	169	190	211	139	154	173	192
20	189	208	235	260	172	190	214	237
22	228	252	284	315	208	229	259	286
24	272	300	338	375	247	273	308	341
26	319	352	397	440	290	321	361	400
28	370	409	461	510	336	372	419	464
32	483	534	602	666	439	486	547	606
36	611	676	762	843	556	614	693	767
40	(754)	834	940	1041	686	759	855	947



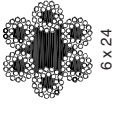
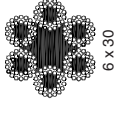

Note 1: For wire ropes with metal core, the minimum breaking loads given in this table are to be increased by 8%.
For preformed wire ropes, the values in the table are to be reduced by 3%.

Table 13 : Minimum breaking loads, in kN, of steel wire ropes with fibre core (non parallel lay ropes with 6 ordinary strands)

Composition of wire rope	 1 + 6 + 12 + 18 + 24			 Fibre core + 9 + 15			 Fibre core + 12 + 18			
	Ordinary									
	Tensile grade			Tensile grade			Tensile grade			
Diameter of rope (mm)	1420	1570	1770	1420	1570	1770	1420	1570	1770	1960
10				39,8	44,0	49,6				54,9
11				48,1	53,2	60,0				66,4
12				57,3	63,3	71,4				79,0
13				67,2	74,3	83,8				92,7
14				77,9	86,2	97,1				108
16				102	113	127				140
18				129	142	161				178
20	165	182	205	159	176	198	220	220	220	199
22	199	220	248	192	213	240	266	266	266	241
24	237	262	296	229	253	285	316	316	316	287
26	278	308	347	269	297	335	371	371	371	337
28	323	357	402	312	345	389	430	430	430	390
32	422	466	526	407	450	507	562	562	562	510
36	534	590	665	515	570	642	711	711	711	645
40	659	728	821	636	703	793	878	878	878	797

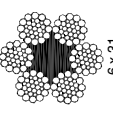
Note 1: For wire ropes with metal core, the minimum breaking loads given in this table are to be increased by 8%.
For preformed wire ropes, the values in the table are to be reduced by 3%.

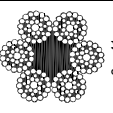
Table 14 : Minimum breaking loads, in kN, of steel wire ropes with fibre core (Warrington and Warrington-Seale lay ropes with 6 strands)

Composition of wire rope	 6 x 19			 6 x 31			 6 x 36			 6 x 41			 6 x 52		
	1 + 6 + (6 + 6)			Composition of type 1 + n + (n + n) + 2n n = 5 n = 6 n = 7 n = 8			Composition of type 1 + n + (n + n) + 2n n = 5 n = 6 n = 7 n = 8			1 + 6 + 9 + (9 + 9) + 18					
Composition and type of strands	Warrington			Warrington - Seale			Warrington - Seale			Warrington - Seale					
Diameter of rope (mm)	Tensile grade			Tensile grade			Tensile grade			Tensile grade					
	1420	1570	1770	1420	1570	1770	1420	1570	1770	1420	1570	1770	1960		
10				46,9	51,8	58,4	64,7								
11				56,7	62,7	70,7	78,3								
12	67,7	74,8	84,4	67,5	74,6	84,1	93,1								
13	79,4	87,8	99,0	79,2	87,6	98,7	109								
14	92,1	102	115	91,8	102	114	127								
16	120	133	150	120	133	150	166								
18	152	168	190	152	168	189	210								
20	188	208	234	187	207	234	259			169	187	211	234		
22	227	252	284	227	251	283	313			205	226	255	283		
24	271	299	337	270	298	336	373			244	269	304	336		
26	318	351	396	317	350	395	437			286	316	357	395		
28	368	407	459	367	406	458	507			332	367	414	458		
32	481	532	600	480	531	598	662			433	479	540	598		
36	609	673	759	607	671	757	838			548	606	684	757		
40	752	831	937	750	829	935	1035			677	749	844	935		

Note 1: For wire ropes with metal core, the minimum breaking loads given in this table are to be increased by 8%.
For preformed wire ropes, the values in the table are to be reduced by 3%.

Table 15 : Minimum breaking loads, in kN, of steel wire ropes with fibre core (Seale lay ropes with 6 strands)

Composition of wire rope	6 x 19 F (**)		6 x 19		6 x 25		6 x 37				
	1 + 9 + 9	1 + (6 + 6 F) + 12	1570	1770	1420	1570	1770	1420	1570	1770	
Composition and type of strands	1 + 6 + 9 + 9										
Diameter of rope (mm)	Seale (1)										
	Tensile grade		1960		1960		1960		Tensile grade		1960
10	47,0	52,0	58,6	64,9	148	164	185	204	268	297	334
11	56,9	62,9	70,9	78,5	183	202	228	252	315	348	392
12	67,7	74,8	84,4	93,4	221	245	276	305	365	404	455
13	79,4	87,8	99,0	110	263	291	328	364	477	527	594
14	92,1	102	115	127	291	342	385	427	527	667	752
16	120	133	150	166	309	396	447	495	604	824	929
18	152	168	190	210	358	468	584	646	745	929	1029
20	188	208	234	260	468	593	739	818	824	929	1029
22	227	252	284	314	593	732	891	1010	1029	1029	1029
24	271	299	337	374	732	809	912	1010	1029	1029	1029
26	318	351	396	439	809	912	1010	1010	1029	1029	1029
28	368	407	459	509	912	1010	1010	1010	1029	1029	1029
32	481	532	600	664	1010	1010	1010	1010	1029	1029	1029
36	609	673	759	841	1010	1010	1010	1010	1029	1029	1029
40	752	831	937	1038	1010	1010	1010	1010	1029	1029	1029

Note 1: For wire ropes with metal core, the minimum breaking loads given in this table are to be increased by 8%.

For preformed wire ropes, the values in the table are to be reduced by 3%.

(1) Minimum breaking loads as indicated correspond to 6 x 19 Seale lay ropes.

For 6 x 19 F Seale Filler lay ropes, sometimes called 6 x 25 Filler, the given values are to be increased by 2%.

4.4.4 Breaking test on individual wires

As an alternative, when the breaking test on full size specimens cannot be performed, the breaking strength of the rope may be determined, in agreement with the Surveyor, as the sum of the actual breaking strengths determined on the individual wires, multiplied by the factor K (realisation factor) applicable in relation to the type and construction of the rope.

The factor K applicable to types of rope in current use is given in Tab 17 (for other types of ropes, the factor K is stated by ^{Tasneef} in each case).

The tensile test is to be performed on at least 10% of the wires of the rope to be tested, with a minimum of two wires per strand.

The wires tested are to satisfy the tensile requirements specified for the wires and the total breaking load of the n wires

tested multiplied by the ratio N/n (where N is the total number of wires of the rope) and by the factor K (depending on the type of the rope) is to be not less than the minimum value specified by the recognised standard applied.

The acceptance of the check of the breaking load of the rope by means of tensile tests on individual wires is, in general, subject to a number of proof tests on samples of full size ropes which are representative of the production for comparison purposes.

4.4.5 Check of the strength of individual wires

This check, consisting of tensile tests on individual wires, is performed only when specified in the purchase order or required by the Surveyor as a check on the base materials employed.

Table 17 : Realisation factor K

Construction of rope (1)	Construction of strands (2)	Type of rope stranding (3)	Realisation factor K (4)	
			Fibre core (5)	Metal core (6)
6 x 7	1 + 6	O	0,90	0,870
6 x 19	1 + 6 + 12	O	0,87	0,835
6 x 19	1 + 9 + 9	S	0,87	0,835
6 x 19 F (7)	1 + (6 + 6 F) + 12	S - F	0,87	0,835
6 x 19	1 + 6 + (6 + 6)	W	0,87	0,835
6 x 24	fibre core + 9 + 15	O	0,87	-
6 x 25	1 + 6 + 9 + 9	S	0,86	0,825
6 x 26	1 + 5 + (5 + 5) + 10	W - S	0,85	0,815
6 x 30	fibre core + 12 + 18	O	0,87	-
6 x 31	1 + 6 + (6 + 6) + 12	W - S	0,85	0,815
6 x 36	1 + 7 + (7 + 7) + 14	W - S	0,85	0,815
6 x 37	1 + 6 + 12 + 18	O	0,85	0,815
6 x 37	1 + 6 + 15 + 15	S	0,85	0,815
6 x 41	1 + 8 + (8 + 8) + 16	W - S	0,85	0,815
6 x 52	1 + 6 + 9 + (9 + 9) + 18	W - S	0,81	0,775
6 x 61	1 + 6 + 12 + 18 + 24	O	0,81	0,775
8 x 19	1 + 9 + 9	S	0,83	-
8 x 19 F (7)	1 + (6 + 6 F) + 12	S - F	0,83	-
17 x 7	1 + 6	O	0,84	0,815
18 x 7	1 + 6	O	0,84	0,815
34 x 7	1 + 6	O	0,80	0,790
36 x 7	1 + 6	O	0,80	0,790

- (1) The first figure gives the number of strands, the second the number of wires in each strand.
- (2) The figures give the number of wires for each layer; the figures in brackets are relevant to wires of the same layer but of two different diameters. The letter F indicates filler wires.
- (3) The type of rope stranding indications are as follows:
 - O : ordinary strands (non-parallel wires);
 - S, S-F, W and W-S (strands with parallel wires) : designate Seale, Seale-Filler, Warrington and Warrington-Seale strandings, respectively.
- (4) The coefficient K is to be reduced by 3% for preformed ropes.
- (5) The fibre core is not considered in the breaking load of the rope.
- (6) The metal core consists of an independent rope (in general 6x7 with centre strand of 7 wires); it may, however, consist of a single strand for wire ropes of 6x7 and 6x19 wires with ordinary strands.
- (7) 6x19 and 8x19 Filler wire ropes are sometimes designated by 6x25 Filler and 8x25 Filler, respectively.

Table 18 : Torsion test for wires - Minimum number of twists

Diameter d (mm)	Galvanising class A			Galvanising class B			
	Tensile grade			Tensile grade			
	1420	1560	1770	1420	1560	1770	1960
$d < 1,3$	19	18	17	31	29	26	18
$1,3 \leq d < 1,8$	18	17	16	30	28	25	17
$1,8 \leq d < 2,3$	18	17	16	28	26	25	16
$2,3 \leq d < 3,0$	16	14	12	26	24	22	15
$3,0 \leq d < 3,5$	14	12	10	24	22	20	13
$3,5 \leq d < 3,7$	12	10	8	20	20	18	12

4.4.6 Torsion test and coiling test on individual wires

Unless otherwise specified in the purchase order, in general only one of these tests is to be performed.

The tests are to be carried out on specimens obtained after galvanising from at least 5% of the number of wires taken at random in several strands with a minimum of 6 wires and a maximum of 10 wires for each diameter.

- Torsion test

The gauge length of the wire specimens, measured between the end terminals, is to be 100 times the wire diameter, but need not exceed 300 mm for wire diameters above 3 mm.

The wire is to be well clamped at the ends and well strained, e.g., under an axial load not exceeding 2% of its nominal breaking load.

The wire is then subjected to torsion until fracture occurs; the torque is to be applied as uniformly as possible, at the approximate rate of 60 - 70 revolutions per minute. The minimum required number of twists without fracture is specified in Tab 18.

The torsion test is not required for wires of diameter lower than 0,5 mm.

- Coiling test

The test consists of coiling a specimen of wire of sufficient length 8 times, in closed coils, around a cylindrical mandrel having a diameter equal to that of the wire; the wire is to be subsequently uncoiled and straightened.

After having been coiled, the zinc coating is not to show any sign of significant cracks or laminations. In the subsequent uncoiling and straightening, fracture of the wire is not to occur.

4.4.7 Checks of the zinc mass

The mass of zinc coating per unit area is required to be checked in accordance with a recognised standard.

The results of this test are to demonstrate compliance with the minimum required values specified in Tab 10.

4.4.8 Check of the uniformity and continuity of the zinc coating

This test is only performed when specified in the purchase order or required by the Surveyor as a production check. It applies only to wires of diameter ≥ 1 mm if galvanised of class A and of diameter $\geq 0,6$ mm if galvanised of class B.

The tests are to be carried out on specimens obtained after galvanising from at least 5% of the number of wires taken at random in several strands with a minimum of 6 wires and a maximum of 10 wires for each diameter.

Unless otherwise specified, the test is performed by submerging a specimen in a water solution of pure crystalline copper sulphate ($\text{Cu SO}_4 \cdot 5 \text{H}_2\text{O}$) containing at least 360g of salt per litre of distilled water at a temperature of $20^\circ\text{C} \pm 2^\circ\text{C}$.

The specimen is to be immersed for a length of at least 80 mm and is to be maintained in vertical position.

Tab 19 shows the minimum number of one-minute submersions, in relation to the wire diameter and galvanising class. After each submersion, the specimen is to be rinsed in running water so as to wash away unbonded copper deposits.

The test is regarded as satisfactory when the specimen does not show (beyond 25 mm from the immersed end) indications of bonded copper deposits, which would mean local lack of zinc coating on the steel surface.

4.5 Identification marking and certification

4.5.1 Upon satisfactory completion of the required tests and examinations, the ropes, packed in the required length for supply, are to be tagged with lead seals stamped with Tasneef brand and further indications, as necessary for identification with the respective test certificates.

4.5.2 The certificates are to contain the essential elements relevant to the rope characteristics, the results of the test and the stamps and markings mentioned in [4.5.1].

Special marking and certification methods may be agreed upon for supplies by Manufacturers granted the use of an alternative testing procedure.

Table 19 : Check of zinc continuity on wire coating

Diameter d of galvanised wire (mm)	Number of one-minute submersions (1)	
	Class A	Class B
$0,6 \leq d < 1,0$	-	0,5
$1,0 \leq d < 1,5$	1,5	1,0
$1,5 \leq d < 1,9$	2,0	1,0
$1,9 \leq d < 2,5$	2,0	1,5
$2,5 \leq d < 3,2$	2,5	1,5
$3,2 \leq d < 3,7$	3,0	2,0

(1) 1,5 submersion means one submersion lasting 1 minute followed by another lasting 30 seconds (the same criteria applies for the other numbers).

5 Fibre ropes

5.1 Application

5.1.1 General

The requirements of this Article apply to natural and synthetic fibre ropes, intended for towing and mooring lines, cargo handling gear or similar applications.

5.1.2 Continuous productions

In the case of continuous production, the Manufacturers may adopt an alternative procedure for testing and inspection subject to the approval of Tasneef

5.2 Manufacture

5.2.1 General

Fibre ropes are to be manufactured in accordance with national or international standards recognised by Tasneef (see [5.3]).

The type and size of ropes are to be in accordance with the requirements specified for each application by the relevant part of the Rules or the approved plans relative to each installation.

5.2.2 Rope materials

Each length of rope is to be manufactured with the same type and quality of natural or synthetic fibre; the natural fibre is to be of suitable type and consistency, free from defects or harmful imperfections. Synthetic fibres are to be of a type and quality which have been recognised as suitable for the intended application.

5.2.3 Manufacturing process and facilities

The manufacturing procedures and relevant facilities are to be suitable and such as to ensure production of the required quality.

The manufacturing process is to be recognised as appropriate by Tasneef

No addition of other materials is to be made and treatments intended to increase the mass of the finished rope are not to

be used; additions of suitable lubricants are to be kept to an absolute minimum.

Treatments intended to prevent decaying and moisture absorption are not to impair the quality of the fibre or the strength of the rope.

The required tests and examinations are to be performed with the appropriate machinery, equipment and procedures recognised by Tasneef the testing machine is to be calibrated.

In particular the dynamometer is to be of a type allowing a constant rate of traverse of the moving element (see [5.4.4]). Other types of dynamometer may be considered by Tasneef in each case.

5.2.4 Quality of ropes - Dimensional tolerances

Ropes are to be free from harmful material or manufacturing defects. As regards lengths, tolerances, marking and packaging, reference is to be made to the requirements specified in the applied standards and in the purchase order.

5.3 Type of ropes

5.3.1 In general, ropes should have either 3-4 strands (plain ropes) or 8 strands (plaited ropes); however, other types of construction may be considered for acceptance by Tasneef

The diameter of mooring lines is to be not less than 20mm.

Ropes may be made of hemp, manila, sisal or synthetic fibres (see [5.2.2]).

The following types and qualities of ropes, complying with recognised standards, are acceptable:

- three-strand plain hemp ropes quality SP and 1 UNITEX CD200
- three- or four-strand plain manila and sisal ropes, ISO 1181
- eight-strand plaited manila and sisal ropes, ISO 1970
- three-strand plain polyamide multifilament ropes, ISO 1140
- three-strand plain polyester multifilament, ISO 1141
- three-strand (plain) and eight-strand (plaited) polypropylene monofilament or film ropes, ISO 1346.

5.4 Sampling and testing

5.4.1 Sampling

Acceptance tests are to be performed on each rope length (defined as either one single length or multiple lengths manufactured with continuity).

Where the rope length is greater than 2000 m, the acceptance tests are to be carried out for every portion of 2000 m.

When the base material used has the same origin and characteristics, the acceptance tests required in [5.4] for each rope length may be performed for each rope construction and diameter.

Suitable sampling and identification procedures are to be adopted, to the Surveyor's satisfaction.

The tests and examinations under [5.4.2], [5.4.3] and [5.4.4] or [5.4.5] are to be performed for acceptance.

5.4.2 Visual examination and check of the diameter and construction

The check of diameter is to be performed during the breaking test. The sample is to be arranged on the testing machine and the diameter of rope (diameter of the circumscribed circumference) is to be measured under the reference load specified in Tab 20.

The visual examination and the check of correct construction and twist are to be performed by the Manufacturer, while random checks are carried out by the Surveyor to the extent deemed necessary.

The results are to comply with the applicable standards.

5.4.3 Check of the linear mass

The linear mass m is given by the formula:

$$m = \frac{m_0}{L}$$

where:

- m_0 : Mass, in grams, of the test piece
 L : Length, in metres, of the test piece under the reference load (see Tab 20), equal to:

$$L = \frac{D_p L_0}{D_0}$$

with:

- D_0 : Initial distance (at least 0,5 m) between the reference marks spaced symmetrically about the mid-point of the test piece when this is laid out by hand on a flat surface
 D_p : Distance between these marks measured under the reference load specified in Tab 20
 L_0 : Initial total length of the test piece (laid out by hand on a flat surface).

5.4.4 Breaking test on full size specimen

The breaking load is to be determined by testing to destruction a sample of rope of sufficient length; in general, the gauge length of the sample is to be not less than 1800 and

900 mm for vegetable fibre ropes and synthetic fibre ropes, respectively.

After the visual and dimensional examination performed at the prescribed load (see [5.4.2]), the sample is subjected to a tension load, steadily increased until fracture occurs.

Depending upon the type of fibre used in manufacturing the ropes, the rate of application of the test load is to be 120-180 mm/min for vegetable fibre ropes and 50-100 mm/min for synthetic fibre ropes.

In the case of synthetic fibre ropes for mooring, the value of elongation A , expressed in percent as given by the following formula, is also to be checked:

$$A = \frac{D_f - D_i}{D_i}$$

where:

- D_f : Distance between marks, on the test specimen, under a load equal to 75% of the minimum specified breaking strength.

D_f may be determined by stopping, for as short a time as possible, the action of the moving element, when the tensile load has reached 75% of the minimum specified breaking strength

- D_i : Distance between marks measured under the initial reference load.

Alternately, elongation A may be determined on a separate test piece with the procedure given in Annex B to ISO Standard 2307.

When the test piece breaks below the specified breaking strength in way of, or in close proximity to, the holding devices of the testing machine possibly due to local damage caused by such devices, the Surveyor may decide to disregard the result of the test.

Alternative types of test pieces and testing procedures, in accordance with recognised standards, may be considered by ^{Tasneef}

Table 20 : Load to be applied to ropes for the measurement of the linear mass and diameter

Nominal diameter (mm)	Reference load (daN) Tolerance: ± 5%		Nominal diameter (mm)	Reference load (daN) Tolerance: ± 5%	
	Natural fibre ropes	Synthetic fibre ropes		Natural fibre ropes	Synthetic fibre ropes
4	2,9	2,0	28	118	93
5	3,9	2,9	30	137	108
6	5,9	3,9	32	157	118
7	7,8	5,9	36	196	147
8	11	7,8	40	235	176
9	13	9,8	16	39	29
10	14	13	18	49	39
11	-	15	20	69	49
12	20	18	22	78	59
13	-	21	24	88	69
14	29	24	26	108	83

The breaking load is to be not less than those of the standards listed in [5.3.1]. Extracts of these standards are given from Tab 22 to Tab 27.

The value of elongation A, for which no minimum requirements are given, is used only for determination of the equivalence between synthetic and natural fibre ropes with the formula given in Pt B, Ch 10, Sec 4, [3.5.6] of Tasneef Rules for the Classification of Ships, and therefore for definition of the minimum breaking load of the synthetic fibre ropes for mooring, in relation to the Equipment Number of the yacht.

5.4.5 Breaking test on individual yarns

When the breaking test on full size test pieces cannot be performed, alternative test procedures may be considered and, if used, they are to be reported in the relevant testing documentation.

To this end, the procedure outlined in Annex A to ISO Standard 2307 is appropriate and its main points are included below, with the premise that it is applicable to ropes having breaking strengths above 25000 daN and made from one material and one linear mass of twisted rope yarns.

A sufficient length of rope is to be untwisted avoiding any rotation of the individual rope components (e.g. yarns, strands) about their own axes. A number of yarns equal to

half the number expressing the nominal diameter of the rope in mm is to be tested; one fifth are to be selected from the centre of the strand in the case of 3 or 4-strand ropes, while in the case of 8-strand ropes half of the yarns are to be selected from S-twist strands and half from Z-twist strands (for S and Z see ISO 2307).

Table 21 : Moisture content and correction factor

Moisture content (%)	Correction factor
8	1,28
10	1,14
14	0,90
16	0,75

The calculated breaking strength of the rope F_c is given by the following formula:

$$F_c = F_f \cdot n \cdot K$$

where:

F_f : Average strength of the yarns, in daN

n : Number of yarns in the rope

K : Realisation factor given in Tab 28.

Table 22 : Main characteristics of 3-strand plain hemp ropes

Linear mass (g/m) ± 5% (1)	Nominal diameter (mm) (2)	Minimum breaking strength (daN) (3)		Linear mass (g/m) ± 5% (1)	Nominal diameter (mm) (2)	Minimum breaking strength (daN) (3)	
		Grade SP	Grade 1			Grade SP	Grade 1
12,5	4	137	122	676	30	7170	6360
19,5	5	210	186	770	32	8140	7180
28,0	6	304	270	972	36	10200	8900
38,0	7	412	368	1198	40	12400	10700
49,5	8	534	476	1442	44	14700	12800
62,5	9	672	603	1709	48	17600	15000
77,0	10	824	740	1998	52	20400	17200
110,5	12	1180	1050	2302	56	23400	19700
150,5	14	1590	1420	2625	60	26500	22200
196	16	2070	1840	2986	64	30100	24900
247	18	2620	2330	3348	68	33600	27500
305	20	3230	2880	3732	72	37100	30500
366	22	3900	3470	4153	76	40800	33400
435	24	4600	2090	4596	80	44700	36500
510	26	5400	4800	5575	88	52300	42600
590	28	6270	5560	6500	96	60600	49400

(1) The linear mass is to be measured under the reference load given in Tab 20.
 (2) The diameter values are given for reference only.
 (3) As regards the conditioning of the sample, reference is to be made to recognised standards. If the moisture content is other than 12%, the breaking strength obtained in such conditions is to be multiplied by the relevant correction factor given in Tab 21.

5.5 Identification, marking and certification

5.5.1 Upon satisfactory completion of the required tests and examinations, the ropes, packed in the required length for supply, are to be tagged with lead seals stamped with Tasneef brand and further indications, as necessary for identification with the respective test certificates.

5.5.2 The certificates are to contain the essential elements relevant to the rope characteristics, the results of the test and the stamps and markings mentioned in [5.5.1].

Special marking and certification procedures may be agreed upon for supplies by Manufacturers granted the use of an alternative testing procedure.

Table 23 : Main characteristics of the 3- and 4-strand plain manila and sisal ropes

Linear mass (g/m) \pm 5% (2)	Nominal diameter (mm) (3)	Minimum breaking strength for 3-strand ropes (daN) (1)			Minimum number N of yarns in each strand for 3- strand ropes (1)
		Manila grade SP	Manila grade 1	Manila grade 2 and Sisal	
54	8	588	534	473	3
68	10	760	691	622	4
105	12	1150	1050	936	6
140	14	1570	1430	1260	8
190	16	2210	1990	1770	11
220	18	2650	2400	2100	13
275	20	3480	3190	2790	16
330	22	4170	3590	3340	19
400	24	4950	4480	3990	23
470	26	5790	5230	4640	27
432	28	6620	5980	5220	31
625	30	7550	6730	5980	36
700	32	8480	7720	6730	40
890	36	10600	9460	8530	51
1100	40	12800	11800	10300	63
1340	44	15500	14000	12500	77
1585	48	18300	16500	14500	91
1870	52	21100	19200	17000	107
2150	56	24500	22000	19500	124
2480	60	27600	24900	22200	142
2880	64	31600	28500	25200	163
3180	68	34500	31400	28000	183
3620	72	38700	35100	32100	205
4000	76	42700	38800	34300	228
4400	80	46900	42700	38000	253
5350	88	55900	50500	45900	306
6400	96	64700	58800	52500	364

(1) For 4-strand ropes: the minimum breaking strengths are those given in the table reduced by 10% ; the minimum number of yarns in each strand is 0,675 N, where N is the minimum number of strand yarns for 3-strand ropes.

(2) The linear mass is to be measured under the reference load given in Tab 20.

(3) The diameter values are given for reference only.

Table 24 : Main characteristics of 8-strand plaited manila and sisal ropes

Linear mass (g/m) ± 5% (1)	Reference diameter (mm) (2)	Minimum breaking strength (daN)			Minimum number N of yarns in each strand
		Manila grade SP	Manila grade 1	Manila grade 2 and Sisal	
285	20	3480	3190	2790	6
395	24	4950	4480	3990	8
545	28	6620	5980	5220	11
730	32	8480	7720	6730	15
910	36	10600	9460	8520	19
1135	40	12800	11800	10300	23
1360	44	15500	14000	12500	28
1635	48	18300	16500	14500	33
1910	52	21100	19200	17000	39
2230	56	24500	22000	19500	45
2550	60	27600	24900	22200	52
2910	64	31600	28500	25200	59
3270	68	34500	31400	28000	66
3680	72	38700	35100	321000	74
4090	76	42700	38800	34300	83
4550	80	46900	42700	38000	92
5500	88	55500	50500	45900	111
6400	96	64700	58800	52500	132

(1) The linear mass is to be measured under the reference load given in Tab 20.
(2) The reference diameter is based approximately on the diameter of 3-strand manila and sisal ropes having the same number of yarns.

Table 25 : Main characteristics of plain 3-strand polyamide multifilament ropes

Linear mass (g/m) ± 5% (1)	Diameter (mm) (2)	Minimum breaking strength (daN)	Linear mass (g/m) ± 5% (1)	Diameter (mm) (2)	Minimum breaking strength (daN)
11,0	4	314	375	24	11800
16,5	5	490	510	28	15500
23,7	6	735	665	32	19600
32,0	7	1000	840	36	24400
42,0	8	1330	1040	40	29400
53,0	9	1670	1260	44	35100
65,0	10	2040	1500	48	41200
79,0	11	2450	1760	52	47900
94,0	12	2940	2030	56	54900
111	13	3430	2330	60	62600
128	14	4020	2650	64	70600
166	16	5200	3360	72	88200
210	18	6570	4150	80	107800
260	20	8140	5020	88	128400
315	22	9800	5980	96	151000

(1) The linear mass is to be measured under the reference load given in Tab 20.
(2) The diameter values are given for reference only.

Table 26 : Main characteristics of plain 3-strand polyester multifilament ropes

Linear mass (g/m) ± 5% (1)	Diameter (mm) (2)	Minimum breaking strength (daN)	Linear mass (g/m) ± 5% (1)	Diameter (mm) (2)	Minimum breaking strength (daN)
14,6	4	290	460	24	8960
20,0	5	392	630	28	12000
30,0	6	554	820	32	15400
40,0	7	755	1040	36	19000
51,0	8	1000	1280	40	23500
66,0	9	1250	1550	44	27900
81,0	10	1560	1850	48	32900
97,0	11	1880	2150	52	38400
116	12	2230	2510	56	43900
135	13	2670	2880	60	48900
157	14	3120	3280	64	56800
205	16	3980	4150	72	70700
260	18	4980	5120	80	86700
320	20	6230	6140	88	104000
385	22	7470	7360	96	123000

(1) The linear mass is to be measured under the reference load given in Tab 20.

(2) The diameter values are given for reference only.

Table 27 : Main characteristics of 3-strand (plain) and 8-strand (plaited) polypropylene monofilament or film ropes

Linear mass (g/m) ± 5% (1)	Diameter (mm) (2)	Minimum breaking strength (daN) (3)	Linear mass (g/m) ± 5% (1)	Diameter (mm) (2)	Minimum breaking strength (daN) (3)
17	6	539	589	36	15800
30	8	941	720	40	19100
45	10	1400	880	44	23000
65	12	1990	1040	48	26700
90	14	2740	1220	52	30900
115	16	3430	1420	56	35300
148	18	4370	1630	60	40400
180	20	5270	1850	64	45700
220	22	6370	2340	72	57400
260	24	7450	2900	80	70600
355	28	9900	3510	88	84700
460	32	12600	4170	96	100000

(1) The linear mass is to be measured under the reference load given in Tab 20.

(2) The diameter values are given for reference only.

(3) In the case of yarn fibril-film ropes, the breaking strengths given in the table are reduced by 15%.

Table 28 : Realisation factor K

Nominal or refer-encediam-eter (mm)	Natural fibre ropes				Synthetic fibre ropes			
	Hemp	Manila or Sisal			Polyamide	Polyester	Polypropylene	
	3-strand	3-strand	4-strand	8-strand	3-strand	3- strand	monofilament 3- or 8-strand	film (1) 3- or 8-strand
40	-	-	-	-	0,7095	-	-	-
44	-	-	-	-	0,7022	0,5705	-	-
48	-	-	-	-	0,6958	0,5655	0,8719	0,890
52	-	-	-	-	0,6900	0,5610	0,8646	0,880
56	-	-	-	-	0,6850	0,5572	0,8583	0,875
60	0,664	0,592	0,533	-	0,6808	0,5536	0,8531	0,870
64	0,659	0,589	0,530	0,610	0,6778	0,5502	0,8483	0,865
68	0,653	0,585	0,527	0,527	-	-	-	-
72	0,647	0,582	0,524	0,603	0,6700	0,5446	0,8395	0,855
76	0,643	0,579	0,521	0,600	-	-	-	-
80	0,640	0,577	0,519	0,598	0,6750	0,5400	0,8332	0,845
88	0,638	0,574	0,517	0,595	0,6613	0,5367	0,8286	0,840
96	0,636	0,572	0,515	0,593	0,6578	0,5333	0,8242	0,835

(1) These values are only applicable when the fibre film rope yarns have an elongation at break of at least 7%; the method is not to be used when the elongation value is lower. Moreover these values are not applicable when the film yarns are of fibril type.

6 Side scuttles, windows and their frames and glass panes

6.1 Application

6.1.1 The testing required in this Article is compulsory for sidescuttles, windows and relevant glass panes and frames.

6.2 Manufacture

6.2.1 General

Sidescuttles and windows which are subject to inspection are to be manufactured in accordance with approved plans or standards and specifications recognised by Tasneef

Manufacturing procedures are to be of appropriate type, to the Surveyor's satisfaction.

6.2.2 Frame materials

Materials are to be of appropriate type and properties, as required in the approved plans or applicable standards.

They are to comply with the requirements of Chapter 2, in relation to the type of material and the nature of the product.

Subject to approval for each case or application, the following types of material and products are generally regarded as appropriate:

- hull steel plates, shapes and bars having R_m in the range 400-490 N/mm²
- steel forgings and castings
- brass plates, shapes, bars and castings
- light alloy castings and semi-finished products, of category Al-Mg or Al-Mg-Si.

Subject to approval in individual cases, nodular cast iron of type GS400 or GS370 may also be used.

6.2.3 Glass panes

The glass panes are to be of appropriate type and quality, manufactured in accordance with suitable procedures, to the satisfaction of Tasneef by recognised Manufacturers.

6.2.4 Quality of materials

The product is to be free from detrimental defects.

6.3 Inspections and tests

6.3.1 Frame material tests (1/1/2017)

Materials are to comply with the applicable requirements and to be tested or certified accordingly; depending on the individual cases, they are also to be submitted to the following additional tests :

a bend test, as indicated below, depending on the type of material:

- brass products: $d \leq 1 s$ $\alpha \geq 60^\circ$
- light alloy products: $d \leq 3 s$ $\alpha \geq 60^\circ$
- cast iron: $d \leq 4 s$ $\alpha \geq 60^\circ$

where:

s : Thickness of the specimen (which, as far as possible, should be equal to the thickness of the product)

d : Diameter of the mandrel

α : Required bend angle, which is to be attained without cracks or other defects.

For castings, as an alternative to the bend test performed on specimens, it may be agreed to perform a bend test directly on a completed piece. Such test may also be required by

the Surveyor as an additional random check. When this test is performed as an alternative to that on specimens, the number of pieces tested is to be one for every batch of not more than 50 equal pieces (25 in the case of cast iron products) originating from the same heat.

These tests are to be performed on a mandrel having a diameter equal to twice the thickness of the piece (but not less than 50 mm in the case of cast iron products); the required bend angles which are to be attained without cracks or other defects depending upon the material and the finished product are as follows:

- steel castings:
 - fixed frames, window frames and dead covers: $\alpha \geq 20^\circ$
- brass castings:
 - fixed frames and window frames: $\alpha \geq 10^\circ$
 - dead covers: $\alpha \geq 15^\circ$
- light alloy castings:
 - fixed frames and window frames: $\alpha \geq 6^\circ$
 - dead covers: $\alpha \geq 15^\circ$
- malleable or nodular cast iron: $\alpha \geq 15^\circ$.

See also Pt B, Ch 1, Sec1, [5.6.14].

6.3.2 Glass panes (1/1/2017)

See Pt B, Ch.1, Sec 1, [5.6.5].

Table 29 : Hydrostatic test pressure for glass panes of sidescuttles and windows

Thickness of glass pane (mm)	Pressure (N/mm ²) for a glass pane net diameter (mm) of:					
	200	250	300	350	400	450
6	0,33	0,21	-	-	-	-
8	0,58	0,37	0,26	0,19	-	-
10	0,92	0,58	0,41	0,30	0,23	0,18
12	1,32	0,84	0,59	0,43	0,33	0,26
15	-	1,32	0,92	0,67	0,51	0,41
19	-	-	1,47	1,08	0,83	0,65

Table 30 : Punch test load

Thickness of glass pane (mm) (tolerance: 0 +2)	Test loads (N) for a hole diameter in support plate of:	
	200 mm	150 mm
6	3400	3500
8	6500	6700
10	10200	11000
12	15500	16500
15	24000	25500
19	33400	36800

Figure 8 : Testing apparatus for punch testing toughened glass panes

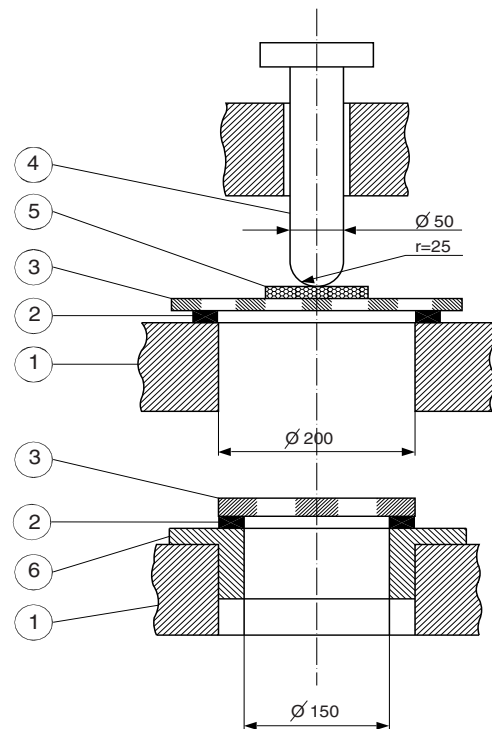

- 1 : Steel Plate with upper flat surface and rounded edges
- 2 : Rubber ring with IRHD 40 - 60
- 3 : Glass pane
- 4 : Punch D 50 mm with lower hemispherical part
- 5 : Felt disc 5 mm thickness
- 6 : Adapter for testing glass panes having diameters < 250 mm

Note 1: Testing equipment

The equipment can be used for glass panes of sidescuttles having nominal diameter 200, 250 mm or greater and for glass of rectangular windows of any size.

The base of the testing equipment is formed by a steel platform with upper flat surface provided with a 200 mm central hole with rounded edges (1); a rubber ring (2), having hardness in the range from 40 to 60 IRHD (International Rubber Hardness Degrees), with an inside diameter of 200 mm, thickness of 2 mm and width of at least 15 mm, located around the hole, between the steel plate and the glass pane, so as to compensate for any slight irregularities of the platform and to prevent the edges of the platform from bearing directly against the glass pane; a suitable adapter provided with a hole of 150 mm (6) with rounded edges to be used when testing glass panes having a diameter of 200 mm (in these cases, a rubber ring having an inside diameter of 150 mm is to be interposed between the upper surface of the adapter and the glass pane).

The glass pane to be tested (3) is positioned over the hole in the platform and a shaft (4) with a diameter of 50 mm and a fully rounded end is arranged above the glass pane along the axis of the hole.

A felt disk (5) having a thickness of 5mm is arranged between the shaft and the glass pane, for the purpose of distributing the load.

Note 2: Testing procedure

The applied load is to be increased at a rate of 1000 N per second up to the test load specified in Tab 30. The test load is to be main-

tained for a period of at least 5 seconds and is then to be removed gradually.

The glass panes are to withstand the required test load without fracture.

6.3.3 Visual and dimensional examination

The following examinations are to be performed:

- a) visual examination
- b) dimensional and conformity checks to be performed by the Manufacturer, with checks at the discretion of the Surveyor.

6.4 Identification and marking

6.4.1 All glass panes tested with satisfactory results are to be marked by the Manufacturer in a suitable position which remains clearly visible after the glass pane has been installed, as follows:

- trade mark and/or name of the Manufacturer
- Tasneef brand
- nominal thickness, in mm.

In the case of glass panes tested with the punch test, the special marking mentioned in ISO 614 is to be used as follows:

- transparent glass panes: single line triangle
- matt glass panes: double line triangle.

The nominal thickness of the glass pane, in mm, is to be marked inside the above triangles.

The markings identifying the origin of the glass pane are to be specified to ^{Tasneef} when the individual Manufacturers are recognised.

6.5 Sidescuttle test

6.5.1 Testing

Sidescuttles are to be submitted to the following tests:

- a) watertight test
- b) shop test
- c) mechanical strength test.

6.5.2 Watertight test (1/1/2017)

The prototype of the mass production is to be submitted to a watertight test. The relevant hydrostatic test pressures are given in Pt B, Ch 1, Sec 1, [5.6.7].

6.5.3 Shop test (1/1/2017)

An equivalent hydraulic test is to be carried out before despatch by means of batch testing.

At least two sidescuttles are to be tested for each batch.

The sidescuttles are to be tested by being subjected to the hydraulic pressures defined in Pt B, Ch 1, Sec 1, [5.6.18] on the portlight and on the deadlight.

6.5.4 Mechanical strength test (1/1/2017)

See Pt B, Ch 1, Sec 1, [5.6.18].

SECTION 2

VARIOUS FINISHED PRODUCTS

1 Cast copper alloy propellers and propellers blades

1.1 Application

1.1.1 The requirements of this Article are applicable to the moulding, casting, inspection and repair procedures of new cast copper alloy propellers, blades and bosses.

1.1.2 These requirements may also be applied for the repair and inspection of propellers which become damaged during service.

1.2 Manufacture

1.2.1 All castings are to be manufactured at foundries approved by ^{Tasneef}

1.2.2 These castings are to be manufactured and tested in accordance with the appropriate requirements of Chapter 1 and Chapter 2 and the specific requirements of this Article.

1.3 Quality of castings

1.3.1 All castings are to be free from surface or internal defects liable to impair their use. Minor casting defects which may still be visible after machining, such as small cold shots and scabs, are to be trimmed off by the Manufacturer.

1.4 Condition of supply

1.4.1 At the option of the Manufacturer, castings may be supplied in the "as cast" or heat treated condition.

1.5 Chemical composition

1.5.1 Typical copper propeller alloys are grouped into the four types CU1, CU2, CU3, and CU4 depending on their chemical composition as given in Tab 1. Copper alloys whose chemical composition deviates from the typical values of Tab 1 are to be specially approved by ^{Tasneef}

1.5.2 The Manufacturer is to maintain records of the chemical analyses of the production casts, which are to be

made available to the Surveyor so that he can satisfy himself that the chemical composition of each casting is within the specified limits.

1.5.3 For copper-based alloys CU1 and CU2, in order to ensure adequate cold ductility and corrosion fatigue resistance, the proportion of beta phase is to be kept low. For this purpose, the zinc equivalent defined by the following formula is not to exceed a value of 45 %:

$$\text{Zinc equivalent (\%)} = 100 - (100 \cdot \%Cu / 100 + A)$$

in which A is the algebraic sum of the following values :

$$\begin{aligned} & 1 \cdot \%Sn \\ & 5 \cdot \%Al \\ & -0,5 \cdot \%Mn \\ & -0,1 \cdot \%Fe \\ & -2,3 \cdot \%Ni \end{aligned}$$

Note 1: The negative sign in front of the element Mn, Fe and Ni signifies that these elements tend to reduce the proportion of beta phase.

1.5.4 In addition to [1.5.3], the CU1 and CU2 type alloys are to contain an alpha phase component of at least 25%; this is to be checked on a test bar by the Manufacturer.

1.6 Mechanical properties

1.6.1 The requirements relevant to the mechanical properties are shown in Tab 2.

The values given in Tab 2 are applicable to test specimens taken from separately cast samples in accordance with Fig 1, or with any other recognised national standard.

It is to be noted that these properties are generally not representative of the mechanical properties of the propeller casting itself, which may be lower than that of a separately cast test coupon.

For integrally cast test specimens, the requirements are to be specially agreed with ^{Tasneef} wherever possible, the test samples are to be located on the blades in an area lying between 0,5 to 0,6 R, where R is the radius of the propeller. The test sample material is to be removed from the casting by non-thermal procedures.

Table 1 : Typical chemical composition of propeller and propeller blade castings

Alloy Type	CHEMICAL COMPOSITION (%)							
	Cu	Sn	Zn	Pb	Ni	Fe	Al	Mn
CU1	52 - 62	0,1 - 1,5	35 - 40	max. 0,5	max. 1,0	0,5 - 2,5	0,5 - 3,0	0,5 - 4,0
CU2	50 - 57	max. 0,15	33 - 38	max 0,5	3,0 - 8,0	0,5 - 2,5	0,5 - 2,0	1,0 - 4,0
CU3	77 - 82	max. 0,1	max. 1,0	max 0,03	3,0 - 6,0	2,0 - 6,0	7,0 - 11,0	0,5 - 4,0
CU4	70 - 80	max. 1,0	max. 6,0	max 0,05	1,5 - 3,0	2,0 - 5,0	6,5 - 9,0	8,0 - 20,0

Table 2 : Mechanical properties of cast copper alloys for propellers and propeller blade castings

Alloy type	Proof stress $R_{p0.2}$ (N/mm ²) min.	Tensile strength R_m (N/mm ²) min.	Elongation A5 (%) min.
CU1	175	440	20
CU2	175	440	20
CU3	245	590	16
CU4	275	630	18

Note 1:The values shown are related to specimens taken from separately cast samples as per Fig 1 or recognised national standards.

Note 2:The 0,2% proof stress values are to be determined for all keyless type propeller castings. For other types of propeller casting, these values are given for information purposes only and, unless expressly required, their determination may be omitted during testing.

The mechanical properties of alloys not meeting the limiting values of Tab 2 are to comply with the requirements of the relevant specification to be approved by Tasneef

1.7 Sampling and testing

1.7.1 Test samples are to be provided from each cast used for the manufacture of propeller blade casting.

1.7.2 The test samples are to be of keel block type, in accordance with the dimensions in Fig 1, and are to be cast in moulds made from the same type of materials as used for the castings.

1.7.3 Where castings are supplied in the heat treated condition, the test samples are to be heat treated together with the casting which they represent.

Figure 1 : Keel block test sample casting

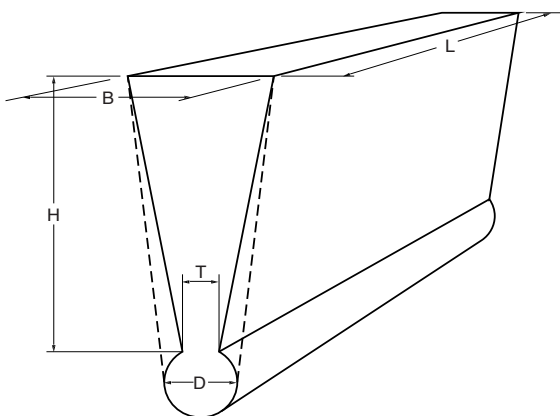

H=100mm ; B=50mm ; L>150mm ; T=15mm ; D=25mm

1.7.4 At least one tensile test specimen is to be taken from each ladle.

1.7.5 The results of all tensile tests are to comply with the requirements given in Tab 2.

1.7.6 Metallographic examination of alloy types CU1 and CU2 is to be verified by determining the proportion of alpha phase. For this purpose, at least one specimen is to be taken from each heat. The proportion of alpha phase is to be determined as the average value of 5 counts. The requirements of [1.5.4] are to be fulfilled.

1.8 Visual and dimensional examination

1.8.1 Propeller castings are to be visually inspected during the various stages of manufacture.

1.8.2 All finished castings are to be presented for examination by the Surveyor, and this is to include the bore and the examination of internal surfaces where applicable.

1.8.3 The dimensions, the dimensional and geometrical tolerances and their verification are the responsibility of the Manufacturer. The report on the relevant examinations is to be submitted to the Surveyor, who may require checks to be made in his presence.

1.8.4 Static balancing is to be carried out on all propellers. Dynamic balancing is required for propellers running above 500 rpm.

1.9 Inspection - Severity zones Non-destructive examinations

1.9.1 Propeller castings are to be cleaned and adequately prepared for inspection.

1.9.2 All finished propellers are to be presented for a comprehensive visual inspection by the Surveyor.

1.9.3 The skew of a propeller is defined as follows:

The maximum skew angle of a propeller blade is defined as the angle, in the projected view of the blade, between a line drawn through the blade tip and the shaft centreline and a second line through the shaft centreline which acts as a tangent to the locus of the mid-points of the helical blade section; see Fig 2.

High skew propellers have a skew angle greater than 25°, low skew propellers a skew angle of up to 25°.

1.9.4 For the purpose of the requirements of this Section, propellers and propeller blades are divided in order of importance into three zones, A, B and C, as shown in :

- Fig 3 for integrally cast low skew propeller
- Fig 4 for blades with skew angles greater than 25°
- Fig 5 for controllable pitch propeller boss
- Fig 6 for controllable pitch and built-up propeller.

Figure 2 : Definition of skew angle

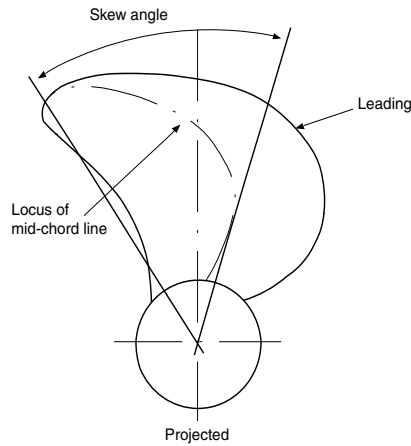

Figure 3 : Severity zones for integrally cast low skew propellers

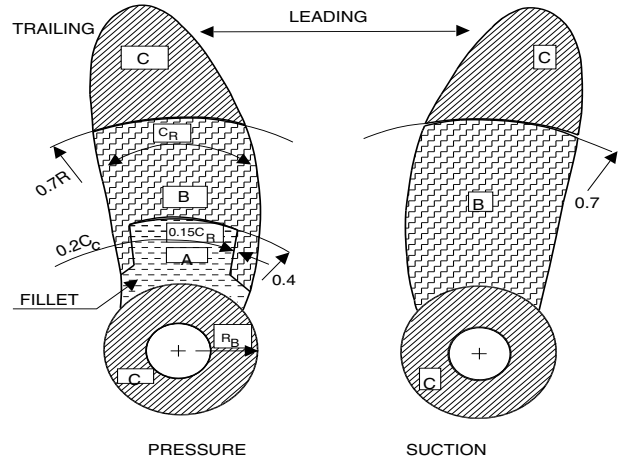

Figure 4 : Severity zones in blades with skew angles > 25°

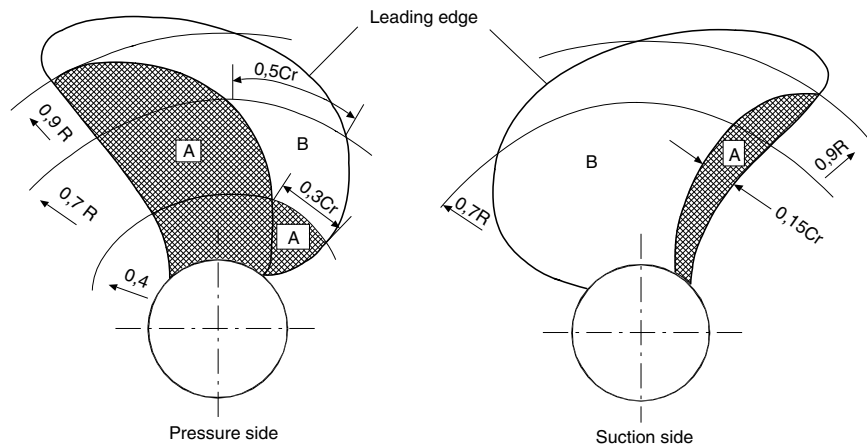
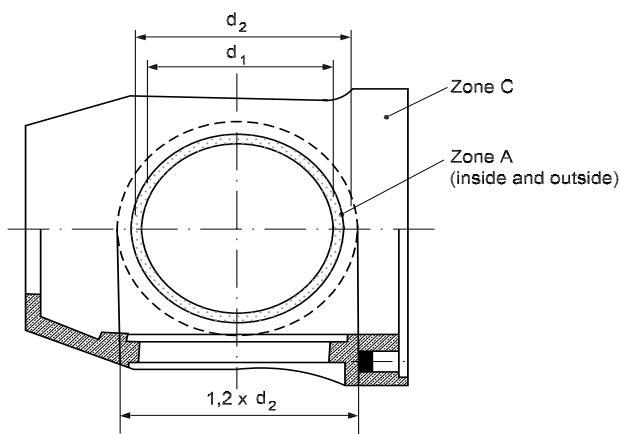

Figure 5 : Severity zones for controllable pitch propeller boss



1.9.5 For castings of solid propellers with a mass exceeding 15 t and castings of individual blades with a mass exceeding 3 t, an area on the pressure side of each blade, including at least the area A and the whole length of the fillet between blade and hub, is to be adequately polished and subjected to visual and dye penetrant examination. In zones B and C the dye penetrant inspection is to be performed by the Manufacturer and may be witnessed by the Surveyor at his request.

1.9.6 If repairs have been made either by grinding or by welding, the repaired areas are to be subjected to the dye penetrant inspection irrespective of their location and/or severity zone.

1.9.7 Where serious doubts arise suggesting that the casting is not free from internal defects, further non-destructive inspections, e.g. radiographic and/or ultrasonic tests, are to be carried out.

Figure 6 : Severity zones for controllable pitch and built-up propeller

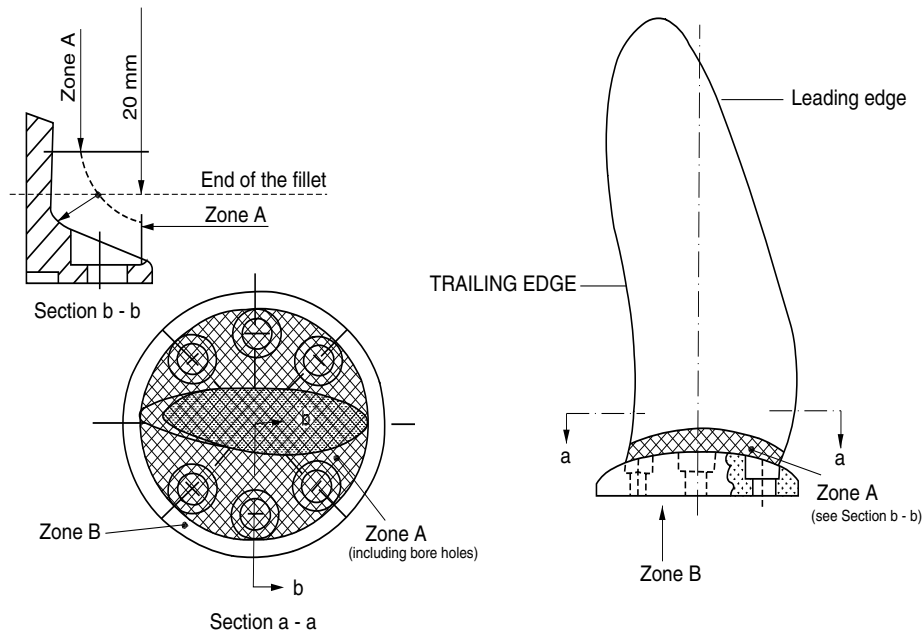

1.10 Repair procedures

1.10.1 Small defects, such as pores less than 1 mm in diameter, may generally be disregarded except where they occur in closely spaced groups

1.10.2 Localised pores on the end face or bore of a propeller boss, which themselves do not affect the strength of the casting, may be filled with a suitable plastic filler after the appropriate preparation of the defective area. The foundry is to keep records and details of all castings which have been rectified.

1.10.3 Where unacceptable defects are found, they are to be removed by machining and the local surface is to be subsequently subjected to dye penetrant examination to ensure that the defects have been completely eliminated.

1.10.4 Cracks, shrinkage cavities, sand, slag and other non-metallic inclusions, blow holes and other discontinuities which may impair the safe service of the propeller are defined as defects and are to be repaired.

1.10.5 After machining is applied for defects which are not to be welded, shallow grooves and depressions resulting from the removal of such defects may, at the discretion of the Surveyor, be accepted provided that they do not imply an appreciable reduction in the strength of the castings and that they are suitably faired on the contour by grinding.

1.10.6 Welded repairs are to be carried out where deemed necessary and accepted by the Surveyor. Welding of areas less than 5cm² and depths of less than 2mm is to be avoided.

1.10.7 Weld repairs are to be carried out in accordance with approved procedures and to the satisfaction of the Surveyor.

1.10.8 In zone A, weld repairs are not permitted unless specially considered by Tasneef

Therefore, where such a repair is proposed, the extent and procedure are to be submitted in detail for acceptance.

1.10.9 Repair by welding in zones B and C is allowed provided complete details of the repair procedures are submitted for acceptance.

1.10.10 The area of any single repair and the maximum total area in any one zone or region are to be kept within the following limits, where "S" is the blade surface:

- Zone A: no repairs
- Zones B and C, single: 0,006S or 60cm², whichever is the greater
- Zone B (leading edge), total: 0,008S or 100cm², whichever is the greater
- Zones B+C, total: 0,02S or 200 cm², whichever is the greater
- other zones, total for each zone: 0,05S or 50 cm², whichever is the greater. "Other zones" means, in particular, the following surfaces:
 - 1) for integrally cast propellers:
 - a) within the bore
 - b) outer surfaces of the boss to the start of the fillet radius
 - c) forward and aft end faces of the boss
 - 2) for separately cast propeller blades:
 - d) surfaces of the flange to the start of the fillet radius.

Where repairs exceeding the above limits are proposed, their type, procedure and extent are to be individually examined by Tasneef before commencement of the repair, and any conditions will be specified.

1.10.11 All welding work is to be carried out in a shop free from draughts and influence of the weather.

1.10.12 All repairs by welding are to be made by certified welders and expert welding supervisors. Proof is to be furnished to the Surveyor that these conditions are satisfied before welding works begins. If a welder has not undertaken repair work for 12 months, or the Surveyor has other reasons to doubt his ability, he is to requalify before making any weld repair.

1.10.13 Metal arc welding with approved electrodes or a continuous wire gas shielded metal arc process is to be employed for all repairs. Welding is to be preferably carried out in the downhand (flat) position. Where necessary, adequate preheating is to be carried out before welding.

1.10.14 With the exception of alloy CU3 castings for welds in Zone C, all weld repairs are to be stress relief heat treated in order to avoid stress corrosion cracking. However, stress relief is also required for welds in this alloy in Zone C if a welding consumable susceptible to stress corrosion cracking is used.

1.10.15 For stress relieving heat treatment, the following temperature ranges apply:

Alloy type:

- CU1 350°C - 500°C
- CU2 350°C - 550°C
- CU3 500°C - 650°C
- CU4 450°C - 650°C

1.10.16 Soaking times are to be in accordance with Tab 3. The heating and cooling are to be suitably controlled to avoid harmful residual stresses.

1.10.17 The foundry is to keep full records detailing the weld procedure, heat treatment and extent and location of repairs made to each casting. These records are to be available for review by the Surveyor.

1.10.18 For hot and cold straightening purposes, static loading only is to be used.

1.10.19 Hot straightening of a bent propeller blade or a pitch modification is to be carried out after heating the bent

region and approximately 500 mm wide zone on either side of it to the suggested temperature range given in Tab 3.

1.10.20 Cold straightening is to be used for minor repairs of tips and edges only and is always to be followed by a stress relieving heat treatment; see Tab 3.

1.11 Identification and marking

1.11.1 The Manufacturer is to adopt a system of identification which will enable all castings to be traced back to their heats.

1.11.2 In addition to the indications required in Ch 1, Sec 1, [4.1.1], all castings which have been tested and inspected with satisfactory results are to be marked with the following details:

- a) Manufacturer's mark
- b) grade of cast material
- c) heat number, casting number or another mark enabling the manufacturing process to be traced back
- d) number of Tasneef certificate
- e) skew angle if in excess of 25°; see [1.9.3].

1.11.3 The Manufacturer is to supply the Surveyor with a certificate containing the following details:

- a) purchaser and order number
- b) shipbuilding project number, if known
- c) description of casting with drawing number
- d) diameter, number of blades, pitch, direction of turning
- e) grade of alloy and chemical composition of each heat
- f) heat or casting number
- g) final weight
- h) results of non-destructive tests and details of test procedure, where applicable
- i) portion of alpha-structure for CU1 and CU2 alloys
- j) results of the mechanical tests
- k) casting identification number
- l) skew angle for high skew propellers; see [1.9.3].

Table 3 : Soaking times for stress relief heat treatment of copper alloy propellers

Stress relief temperature (°C)	Alloy Grade Cu 1 and Cu 2		Alloy Grade Cu 3 and Cu 4	
	Hours per 25 mm of thickness	Maximum recommended total hours	Hours per 25 mm of thickness	Maximum recommended total hours
350	5	15	-	-
400	1	5	-	-
450	1/2	2	5	15
500	1/4	1	1	5
550	1/4	1/2	1/2	2
600	-	-	1/4	1
650	-	-	1/4	1/2

2 Pressure bottles

2.1 Application

2.1.1 General

The requirements of this Article apply to seamless pressure bottles in carbon, carbon manganese and alloy steels, and to welded bottles in carbon and carbon manganese steels.

Seamless bottles are mainly used for carbon dioxide systems and welded bottles for portable fire extinguishers.

Steel grades to be used for the manufacture are to comply with those specified in Chapter 2 as applicable or with recognised standards.

The steel is to be killed and for certain applications, for example low temperature applications, fine grained steel is to be used.

2.1.2 Mass production

In the case of small bottles mass produced by Manufactures who have been approved by Tasneef for this purpose, alternative testing procedures to those indicated in [2.3.1] may be accepted.

2.1.3 Materials other than steel

The requirements relevant to bottles in material other than steel are to be considered on a case-by-case basis, with criteria and procedures as similar as possible to those specified in this Article.

2.2 Manufacture

2.2.1 Bottles are to be manufactured according to approved plans.

The manufacturing process of seamless bottles is to be approved for the individual Manufacturers.

The approval of the manufacturing process is also required for welded bottles intended for portable fire extinguishers having thickness of the cylindrical shell less than 3 mm.

Provisions for approval are given in the document, "Guide for Approval of Manufacturers".

The materials used in the bottle manufacture are to be tested or provided with a Manufacturer's certificate of conformity.

2.3 Inspection and tests

2.3.1 General

The following inspections and tests are to be performed:

- a) sectioning of one bottle from each batch formed of 200 pieces or fraction thereof, homogeneous as regards dimensions, manufacturing process and heat treatment for the execution of :
 - thickness measurements of the shell on three transverse sections in way of neck, middle and bottom end
 - 1 tensile test on longitudinal test specimen, 2 bending tests to be performed along the curvature and, for thicknesses ≥ 5 mm, 3 Charpy V-notch impact tests on longitudinal specimens, to be performed at -

20°C. For low temperature applications, the test temperature is to be specified in the individual cases.

- b) hardness tests to be performed on bottles of quenched and tempered steel and, at the discretion of the Surveyor, also in other cases
- c) external and internal visual examination (direct examination or, in the case of insufficient size of openings, examination by auxiliary means), dimensional check, determination of tare and capacity (such examinations are to be performed by the Manufacturer with checks at the Surveyor's discretion)
- d) hydrostatic test on each bottle; test pressure as required by the relevant Rules or by the particular requirements applicable in the individual cases
- e) non-destructive checks as indicated on the plans at the time of the approval of the manufacturing process
- f) for welded bottles, additional tests on welded joints as specified at the time of the approval of the manufacturing process or indicated on the approved plans.

2.3.2 Tensile test

In the tensile test, the values of the yield strength R_{eH} and $R_{p0.2}$, the tensile strength R_m and the elongation A (%) are to comply with the values specified for the corresponding steel.

The value of A (%) min, for thicknesses equal to or greater than 3 mm, is to be not less than the value calculated with the following formula, and in no case less than 14% :

$$A \geq \frac{2500}{0,224 \cdot R_m}$$

where R_m is the value, in N/mm², of the tensile strength determined by the tensile test.

This requirement for A (%) min may be reduced by 15% for thicknesses less than 3 mm down to 2 mm, and by 30% for thicknesses less than 2 mm.

2.3.3 Bend test

In the bending test, the angle to which the specimen is to be bent without showing defects is 180°; a mandrel having a diameter not exceeding "n" times the thickness of the specimen, depending on the minimum specified tensile strength R_m for the steel, as specified in Tab 4, is to be used.

Table 4 : Coef. n for determination of the max. allowed mandrel diameter in bend test

R_m (N/mm ²)	n
≤ 430	2
431 - 510	3
511 - 590	4
591 - 690	5
691 - 790	6
791 - 890	7
> 890	8

2.3.4 Impact test

In the Charpy V-notch impact test, the value of the absorbed energy, determined as an average of three tests, is to be not less than the value indicated in Tab 5 depending on the minimum tensile strength of the steel.

Table 5 : Impact test - requirements

Steel types	Tensile strength (N/mm ²)	Average impact energy at -20°C min. KV (J/cm ²)
Carbon and carbon- manganese	≤ 510	34
Alloy steels quenched and tempered	> 510	49

2.4 Identification, marking and certification

2.4.1 The Manufacturer is to adopt a system of identification which will enable all finished bottles to be traced to the original materials and their manufacturing.

All bottles which have been tested and inspected with satisfactory results are to be marked with the following details:

- Manufacturer's name or trade mark
- Tasneef brand
- place and date of testing
- production number or other marking enabling the traceability
- test pressure
- additional optional marks such as file number and code of the local inspection office, Surveyor's personal stamp.

Special marking and certification procedures may be agreed upon for supplies by Manufacturers granted the use of an alternative testing procedure.

2.4.2 The testing documentation indicated in Ch 1, Sec 1, [4.2.1] is required and is to include all the information, as appropriate.

The testing or works' certificate of the material used is to be enclosed with the testing documentation.

Where applicable, the reports relevant to the non-destructive examination, pressure test and heat treatment are to be enclosed with the testing documentation.

2.4.3 Before signing Tasneef inspection certificate, the Surveyor is to be provided by the Manufacturer with a written declaration stating that the bottles have been manufactured by a process approved by Tasneef they comply with the applicable requirements and they have been satisfactorily tested in accordance with Tasneef Rules.

3 Cast steel propellers and propeller blades

3.1 Application

3.1.1 The requirements of this Article are applicable to the moulding, casting, inspection and repair procedure of cast steel propellers, blades and bosses.

3.1.2 Where the use of alternative alloys is proposed, particulars of chemical composition, mechanical properties and heat treatment are to be submitted for approval.

3.1.3 These requirements may also be used for the repair and inspection of propellers which become damaged during service, subject to prior agreement with Tasneef

3.2 Manufacture

3.2.1 All propellers, blades and bosses are to be manufactured at foundries approved by Tasneef. The scope of the procedure tests involved in the approval is to be agreed.

3.2.2 These castings are to be manufactured and tested in accordance with the appropriate requirements of Chapter 1 and Chapter 2 and the specific requirements of this Article.

3.3 Quality of castings

3.3.1 All castings are to be free from surface and internal defects liable to impair their in-service performance.

3.4 Condition of supply

3.4.1 Martensitic castings are to be supplied in the austenitized and tempered condition. Austenitic castings are to be solution treated.

3.5 Chemical composition

3.5.1 Typical cast steel propeller alloys are grouped into four types depending on their chemical composition as given in Tab 6.

Table 6 : Typical chemical composition of steel propeller castings

Alloy type	C Max. (%)	Mn Max. (%)	Cr (%)	Mo (1) Max. (%)	Ni (%)
Martensitic (12Cr 1Ni)	0,15	2,0	11,5-17,0	0,5	Max. 2,0
Martensitic (13Cr 4Ni)	0,06	2,0	11,5-17,0	1,0	3,5-5,0
Martensitic (16Cr 5Ni)	0,06	2,0	15,0-17,5	1,5	3,5-6,0
Austenitic (19Cr 11Ni)	0,12	1,6	16,0-21,0	4,0	8,0-13,0
(1) Minimum values are to be in accordance with recognised national or international standards					

3.6 Mechanical properties

3.6.1 The requirements relevant to the mechanical properties are shown in Tab 7. These values refer to the test specimens machined from integrally cast test bars attached to the hub or on the blade.

Where possible, the test bars attached on the blades are to be located in an area lying between 0,5 to 0,6R, where R is the radius of the propeller.

The test bars are not to be detached from the castings until the final heat treatment has been carried out. Removal is to be by non-thermal procedures.

Table 7 : Mechanical Properties for steel propeller castings

Alloy type	Proof stress $R_{p0.2}$ min. (N/mm ²)	Tensile strength R_m min. (N/mm ²)	Elongation A_5 min. (%)	Red. of area Z min. (%)	Charpy V-notch (1) Energy min. (J)
12Cr 1Ni	440	590	15	30	20
13Cr 4Ni	550	750	15	35	30
16Cr 5Ni	540	760	15	35	30
19Cr 11Ni	180 (2)	440	30	40	-
(1) Tests to be made at -10°C for Ice Class Notations IAS, IA and IB only					
(2) $R_{p1.0}$ value is 205 N/mm ²					

3.6.2 Separately cast test bars may be used subject to the prior approval of ^{Tasneef}. The test bars are to be cast from the same heat as the castings represented and heat treated with the castings which they represent.

3.7 Sampling

3.7.1 At least one set of mechanical tests is to be made on material representing each casting.

3.7.2 As an alternative to [3.7.1], where a number of small propellers of about the same size, and less than 1m in diameter, are made from one cast and heat treated in the same furnace charge, a batch testing procedure may be adopted using separately cast test samples of suitable dimensions. At least one set of mechanical tests is to be provided for each multiple of five castings in the batch.

3.8 Visual and dimensional examination

3.8.1 All finished castings are to be 100% visually inspected by the Surveyor. The Surveyor may require areas to be etched for the purpose of investigating weld repairs.

3.8.2 The castings are to be free from cracks, hot tears or other imperfections which, due to their nature, degree or extent, will interfere with the use of the castings.

3.8.3 The dimensions, the dimensional and geometrical tolerances and their verification are the responsibility of the Manufacturer. The report on the relevant examinations is to be submitted to the Surveyor, who may require checks to be made in his presence.

3.8.4 Static balancing is to be carried out on all propellers in accordance with the approved drawings.

Dynamic balancing may be necessary for propellers running above 500 rpm.

3.9 Non-destructive examinations - Severity Zones

3.9.1 All finished castings are to be submitted to non-destructive testing in accordance with the requirements given in [3.9.2] to [3.9.9]].

3.9.2 In order to relate the degree of non-destructive testing to the criticality of imperfections, propeller blades are divided into three Severity Zones designated A, B and C. In addition, a distinction is made between low skew and high skew propellers. See [1.9].

3.9.3 For all propellers, separately cast blades and hub, the surface covered by severity Zones A, B and C are to be dye penetrant tested. Testing of Zone A is to be undertaken in the presence of the Surveyor. In Zones B and C the dye penetrant inspection is to be performed by the Manufacturer and may be witnessed by the Surveyor at his request.

3.9.4 If repairs have been made by grinding or by welding, the repaired areas are additionally to be subjected to dye penetrant testing irrespective of their location and/or severity zone. Weld repairs are, irrespective of their location, always to be assessed according to Zone A.

3.9.5 Where serious doubts arise that the casting is not free from internal defects, further non-destructive inspections, e.g. radiographic and/or ultrasonic tests, are to be carried out. The acceptance criteria are to be agreed between the Manufacturer and ^{Tasneef}.

3.9.6 In the dye penetrant inspection an indication is the presence of detectable bleed-out of the penetrant liquid from the material discontinuities appearing at least 10 minutes after the developer has been applied. The following definitions apply:

- Linear indication: an indication in which the length is at least three times the width;
- Nonlinear indication: an indication of circular or elliptical shape with a length less than three times the width;
- Aligned indications: three or more indications in a line, separated by 2 mm or less edge-to-edge;
- Open indication: an indication that can be detected by use of contrast dye penetrant;
- Non-open indication: an indication that cannot be detected by the use of contrast dye penetrant;
- Relevant indication: an indication that is caused by a condition or type of discontinuity that requires an evaluation. Only indications which have any dimension greater than 1.5mm are to be considered relevant.

3.9.7 For the purpose of evaluating indications, the surface is to be divided into reference areas of 100 cm², which may be square or rectangular with the major dimension not exceeding 250 mm. The area is to be taken in the most unfavorable location relative to the indication being evaluated.

3.9.8 With respect to their size and number, the indications detected are not to exceed the values given in Tab 8.

Table 8 : Allowable number and size of indications depending on severity zones

Severity zone	Max. total number of indications	Indication type	Max. number for each type (1) (2)	Max. dimension of indication (mm)
A	7	Non - linear	5	4
		Linear	2	3
		Aligned	2	3
B	14	Non - linear	10	6
		Linear	4	6
		Aligned	4	6
C	20	Non - linear	14	8
		Linear	6	6
		Aligned	6	6

(1) Single non-linear indications less than 2mm in Zone A and less than 3mm in other zones may be disregarded.

(2) The total number of non-linear indications may be increased to the maximum total number, or part thereof, represented by the absence of linear or aligned indications.

3.9.9 The foundry is to keep records of inspections traceable to each casting. These records are to be reviewed by the Surveyor. The foundry is also to provide the Surveyor with a statement confirming that non-destructive tests have been carried out with satisfactory results.

3.10 Repair procedures

3.10.1 Defective castings are to be repaired in accordance with the requirements given in [3.10.2] to [3.10.7] and, where applicable, the requirements given in [3.10.8] to [3.10.14].

3.10.2 In general the repairs are to be carried out by mechanical means, e.g. by grinding or milling. The resulting grooves are to be blended into the surrounding surface so as to avoid any sharp contours. The local surface is to be subsequently subjected to dye penetrant examination to ensure that the defects have been completely eliminated.

3.10.3 Weld repairs are to be carried out only where deemed necessary and accepted by the Surveyor. All weld repairs are to be documented by means of sketches or photographs showing the location and major dimensions of the grooves prepared for welding. The documentation is to be presented to the Surveyor prior to repair welding.

3.10.4 The weld grooves are to be suitably shaped to allow good access for welding and ground smooth, and complete elimination of the defective material is to be verified by liquid penetrant testing. Welds having an area less than 5 cm² are to be avoided.

3.10.5 Repair by grinding in Severity Zone A is allowed to an extent to maintain the required thickness of the blade. In Zone A, repairs by welding are in general not permitted unless specially considered by Tasneef

Therefore where such a repair is proposed, the extent and procedure are to be submitted in detail for acceptance.

3.10.6 Defects in severity Zone B that are not deeper than $t/40$ (t is the minimum local thickness according to the Rules) or 2 mm, whichever is the greater, are to be removed

by grinding. Defects that are deeper may be repaired by welding subject to the prior approval of Tasneef

3.10.7 Repair by welding is generally permitted in Severity Zone C.

3.10.8 Before welding is started, a detailed welding procedure specification is to be submitted covering the weld preparation, welding positions, welding parameters, welding consumables, preheating, post-weld heat treatment and inspection procedures.

3.10.9 All weld repairs are to be made by qualified welders using qualified procedures. The requirements for welding procedure qualification tests are given in Ch 5, Sec 4.

3.10.10 The metal welding electrode or filler wire used in the procedure tests is to be used. The welding consumables are to be stored and handled in accordance with the Manufacturer's recommendations.

3.10.11 All welding work is to be carried out in a shop free from draughts and influence of the weather.

3.10.12 The martensitic steels are to be furnace re-tempered after weld repair. Subject to prior approval, however, local stress relieving may be considered for minor repairs.

3.10.13 On completion of heat treatment the weld and the adjacent material are to be ground smooth. All weld repairs are to be submitted to liquid penetrant examination.

3.10.14 The foundry is to keep full records detailing the weld procedure, heat treatment, inspection and extent and location of repairs made to each casting. These records are to be reviewed by the Surveyor.

3.11 Identification

3.11.1 The Manufacturer is to adopt a system of identification which will be able to suitably identify, prior to

the final inspection by the Surveyor, each individual casting as follows:

- a) Manufacturer's mark
- b) grade of cast material
- c) heat number, casting number or another mark enabling the full history of the casting to be traced back
- d) number of Tasneef certificate
- e) ice class symbol where applicable
- f) skew angle for high skew propellers.

3.11.2 When the casting has been accepted Tasneef stamp is to be put on with the date of the final inspection of the casting.

3.12 Certification

3.12.1 The Manufacturer is to supply the Surveyor with an inspection certificate containing the following details:

- a) Purchaser and heat number

- b) shipbuilding or yacht identification, if known
- c) description of the casting with drawing number
- d) diameter, number of blades, pitch, direction of turning
- e) type of alloy, heat or casting number and chemical composition
- f) final mass
- g) skew angle for high skew propellers
- h) details of time and temperature of heat treatment
- i) results of mechanical tests.

3.12.2 The Manufacturer is to provide a statement of the results of non-destructive tests and details of test procedures and, where applicable, records of weld repairs as required by [3.10.14].

Part D
Materials and Welding

Chapter 5
WELDING

SECTION 1 REQUIREMENTS

SECTION 1 REQUIREMENTS

1 General

1.1 Application

1.1.1 (1/1/2023)

Reference is to be made, as far as practicable, to the applicable requirements in Pt D, Ch 5 of the ^{Tasneef} Rules for the Classification of Ships.

Part D
Materials and Welding

Chapter 6
PLASTIC MATERIALS

- SECTION 1 GENERAL REQUIREMENTS**
- SECTION 2 TESTS ON RESINS, REINFORCEMENTS AND COMPONENT**
- SECTION 3 TESTING PROCEDURES**
- SECTION 4 PLASTIC PIPES AND FITTINGS**

SECTION 1

GENERAL REQUIREMENTS

1 Application

1.1 General

1.1.1 Provision is made in this Chapter for the approval requirements for base materials used in the construction or repair of composite vessels, which are intended for classification purpose.

1.1.2 For such materials, the manufacturer's works do not require approval by Tasneef provided that they have a Quality Control procedures certified by Tasneef or other recognized Society.

1.1.3 Where in the other Parts of this Rule a requirement exists for the material to be approved, the test requirements and information to be submitted for polymers, resins, reinforcements and associated materials are defined in Sections 2 and 3. As alternative requested indicated in "Rules for the type-approval of components of composite materials intended for hull construction" can be applied.

1.1.4 For Builders constructing composite vessels, Part B - Chapter 4 - Section 3 provides the minimum material control requirements acceptance of the works by Tasneef

1.1.5 For "plastics material" it is mean an organic substance which may be thermosetting or thermoplastic and which, in its finished state, may contain reinforcements and/or additives.

1.2 Information on material quality and application

1.2.1 The manufacturer is to provide the shipyard with such information as is essential to ensure that the base materials are used with correct procedure according the product specification. Information about the check carried out at the shipyard are to be given.

1.3 Manufacture

1.3.1 Plastics products are to be made at works which have been recognized for the type of product being supplied using base materials that have been approved.

1.3.2 Base materials are to be approved in accordance with the requirements of Sections 2 and 3.

1.3.3 In order that a works can be approved the manufacturer is required to demonstrate to the satisfaction of Tasneef that the necessary manufacturing and testing facilities are available and are supervised by qualified personnel. A specified programme of tests is to be carried out under the supervision of the Tasneef Surveyors, and the results are to be to the satisfaction of Tasneef When a manufacturer has more

than one works, the approval is only valid for the individual works which carried out the test programme.

1.4 Inspection and testing

1.4.1 Before final acceptance, all test materials are to be confirmed as typical of the manufactured product and be submitted to the specified tests and examinations to Surveyor' satisfaction. The results are to comply with the specification and any Rule requirements and are to be to the satisfaction of the Surveyors.

1.4.2 These specified tests and examinations are to be carried out prior to the dispatch of finished products from the manufacturer's works.

1.5 Alternative inspection and testing

1.5.1 Where materials are manufactured in quantity by semi-continuous or continuous processes, as foreseen at Chapter 1, Section 1, an alternative system for testing and inspection may be adopted, subject to the Tasneef agreement.

1.5.2 The manufacturers are to comply with the requirements Chapter 1, Section 1.

1.6 Post-cure heating

1.6.1 Post-cure heating is to be carried out in properly ovens whose temperature is efficiently maintained and have adequate means for control and recording of temperature.

The oven is to be such as to allow the whole "product" to be uniformly heated to the necessary temperature. In the case of very large components which require post-cure heating, alternative methods will be specially considered.

1.7 Test material

1.7.1 Sufficient material is to be provided for the preparation of the test specimens detailed in the specific requirements. It is, however, in the interests of manufacturers to foresee additional material for any re-tests which may be necessary, in case some specimens do not overcome the tests and consequently material rejection.

1.7.2 The samples for testing are to be prepared under conditions that are as close as possible to those under which the product will be used. Where this is not possible, a suitable procedure is to be agreed with Tasneef

1.7.3 During production, check test samples are to be provided as requested by the Surveyor.

1.7.4 In case the taking of these samples is not possible, model samples are to be prepared concurrently with production. The procedure for the preparation of these samples is to be agreed with the Surveyor.

1.7.5 The dimensions, number and orientation of test specimens are to be in accordance with the requirements of a National or International Standard acceptable to Tasneef

1.8 Repairs of defects

1.8.1 Small surface blemishes may be removed by mechanical means (grinding) provided that, after such treat-

ment, the dimensions are acceptable, the area is proved free from defects and is considered acceptable by Surveyor.

1.8.2 Repair procedures for larger defects are to be agreed with Tasneef in advance.

1.9 Identification of products and base materials

1.9.1 The manufacturer of plastics products is to adopt a system of identification which will enable all finished products to be traced to the original batches of base materials.

Right attendance is to be given to Surveyors for tracing, when required, any component or material.

SECTION 2

TESTS ON RESINS, REINFORCEMENTS AND COMPONENT

1 Scope

1.1

1.1.1 (1/1/2021)

This Section gives the tests and data required by ^{Tasneef} for approval of the following materials:

- j) Plywoods.
- k) Adhesive and sealant materials.

Repair compounds.

For the testing of the following material reference is to be made to Rules for the Type Approval of Components of Composite Materials Intended for Hull Construction:

- a) Thermoplastic polymers.
- b) Thermosetting resins.
- c) Reinforcements.
- d) Reinforced thermoplastic polymers.
- e) Reinforced thermosetting resins
- f) Core materials (balsa wood, rigid foams).

2 Plywoods

2.1

2.1.1 All plywoods utilized for construction or repair of pleasure boats Intended for classification purpose are to be approved in accordance with ^{Tasneef} procedure showed in "Rules for the type-approval of marine plywood".

3 Adhesive and sealant materials

3.1

3.1.1 Materials of these types are to be accepted by ^{Tasneef} before use.

3.1.2 The requirements for acceptance are dependent on the nature and the application.

3.1.3 The manufacturer is to submit full details of the product, procedure for method of use, including surface preparation and the intended application.

3.1.4 Any acceptance will be limited to specific applications according to the instructions.

4 Repair compounds

4.1

4.1.1 Materials used for repairs are to be accepted by ^{Tasneef} before use.

4.1.2 For acceptance purposes the manufacturer is to submit full product details, and user instructions, listing the types of repair for which the system is to be used.

4.1.3 Dependent on the proposed uses, ^{Tasneef} shall require some tests.

SECTION 3

TESTING DURING NEW BUILDING

1 General

1.1

1.1.1 (1/1/2021)

This Section details the tests required during construction of a yacht made of composite material.

1.1.2 (1/1/2021)

All the composite materials (resin, reinforcement, core ...) used for the construction of a new building have to be type approved in accordance with the "Rules for the type approval of components of composite materials intended for hull construction", or in any case considered acceptable by ^{Tasneef}

2 Samples

2.1

2.1.1 (1/1/2021)

In general, for each yacht, samples are to be taken from the hull (bottom, sides and bow thruster tunnel) and deck. If different type of construction are used (e.g. monolithic and sandwich) a sample is to be taken from each type.

2.1.2 (1/1/2021)

If it is not possible to take a sample directly from the yacht under construction a suitable number of panels representing the yacht structure may be built together with the yacht only for testing. The panel has to be manufactured, cured and post cured with the same procedures adopted for the yacht.

3 Testing

3.1

3.1.1 (1/1/2021)

The samples have to be subject to the test reported in Tab. 1 in case of monolithic laminate and to the test reported in [4] for sandwich construction. ^{Tasneef} may accept standards different from those reported in Tab.1 provided that they are recognised national or international standards (ASTM, EN, ISO etc.). For sister yachts or if deemed acceptable the Surveyor may not require some of the test reported in Tab.1.

3.1.2 (1/1/2021)

In general, testing is to be carried out by a competent independent laboratory recognised by ^{Tasneef} which, at its discretion, may or may not require witnessing by the Surveyor. Alternatively, testing may be carried out by the Manufacturer but in this case in the presence of a ^{Tasneef} Surveyor.

3.1.3 (1/1/2021)

Mechanical properties are to be established using suitable testing machines of approved types. The machines and other test equipment are to be maintained in a satisfactory condition and are to be calibrated yearly, by ^{Tasneef} or a nationally or internationally recognised authority according to recognised standards. A record of all calibrations is to be kept available and shown to the Surveyor at his request.

3.1.4 (1/1/2021)

The test specimens are to be prepared in accordance with the appropriate national or international standards (ASTM, EN, ISO etc.) used

3.1.5 (1/1/2021)

Strain measurements are to be made by the use of a suitable device. The rate of strain is to be in accordance with the appropriate standard

3.1.6 (1/1/2021)

The number of test specimens from each sample to be tested is to be in accordance with the standard used or, if not indicated, in accordance with the "Rules for the type approval of components of composite materials intended for hull construction"

3.1.7 (1/1/2021)

The results of tests are to be reported according to the provisions in Ch 1, Sec 1, also as regards discarding of test specimens

3.1.8 (1/1/2021)

The mechanical properties for laminate (tensile, compressive and shear strength and corresponding moduli of elasticity) are, in general, to be not less than the values given in Tab.2.

Table 1 : Test standards for laminate specimens (1/1/2021)

Test	Standard
Tensile strength (1)	<ul style="list-style-type: none"> ISO 527-4 (speed= 2 mm/1' specimens Type II or III) ASTM D 638
Flexural strength	<ul style="list-style-type: none"> ISO 14125 (speed = t/2 mm/1') Method A ASTM D 790
Compressive strength	<ul style="list-style-type: none"> ISO 604 (speed= 1 mm/1') ASTM D 695
Interlaminar shear	<ul style="list-style-type: none"> ISO 14130 ASTMD 3846
Water absorption	ASTM D 570 + ISO 62 Method 1
Glass content	ISO1172
(1) see [3.1.6].	

Table 2 : Minimum property values for laminates (1/1/2019)

R_m = ultimate tensile strength	$= 1278 G_c^2 - 510 G_c + 123$	85
E = tensile modulus of elasticity	$= (37 G_c - 4,75) \cdot 10^3$	6350
R_{mc} = ultimate compressive strength	$= 150 G_c + 72$	117
E_c = compressive modulus of elasticity	$= (40 G_c - 6) \cdot 10^3$	6000
R_{mf} = ultimate flexural strength	$= (502 G_c^2 + 107)$	152
E_f = flexural modulus of elasticity	$= (33,4 G_c^2 + 2,2) \cdot 10^3$	5200
R_{mt} = ultimate shear strength	$= 80 G_c + 38$	62
G = shear modulus of elasticity	$= (1,7 G_c + 2,24) \cdot 10^3$	2750
R_{mti} = ultimate interlaminar shear strength	$= 22,5 - 17,5 G_c$	17

4 Structural core materials

C273 to be carried out to verify that the detach occurs in the core and not at the interface core/skin.

4.1

4.1.1 (1/1/2021)

In addition to the tests carried out on the single skins a shear test on the sandwich in accordance with ISO 1922 or ASTM

SECTION 4

PLASTIC PIPES AND FITTINGS

1 General

with the provisions of the rules, are indicated in Part C, Chapter 1, Appendix 3 of this Rules.

1.1 General

1.1.1 The general requirements for plastics pipes and fittings which can be used in piping systems in accordance